

2018



Traffic Data Report
for the Illinois Tollway System

CDM
Smith

2018 Traffic Data Report

for the Illinois Tollway System



Prepared for the Illinois State Toll Highway Authority

Prepared by CDM Smith



CONTENTS

SECTION 1: THE ILLINOIS TOLLWAY SYSTEM

SECTION 2: JANE ADDAMS MEMORIAL TOLLWAY

SECTION 3: TRI-STATE TOLLWAY

SECTION 4: REAGAN MEMORIAL TOLLWAY

SECTION 5: VETERANS MEMORIAL TOLLWAY

SECTION 6: ILLINOIS ROUTE 390 TOLLWAY

APPENDICES:

APPENDIX – A: 2018 SYSTEMWIDE ANNUAL AVERAGE DAILY
TRAFFIC SCHEMATICS

APPENDIX – B: 2018 SYSTEMWIDE AM AND PM PEAK HOUR
TRAFFIC SCHEMATICS

APPENDIX – C: 2018 LANE CONFIGURATION SCHEMATICS

APPENDIX – D: PLAZA LANE LISTING

(Please refer to individual sections for detailed Table of Contents)

Section 1

The Illinois Tollway System

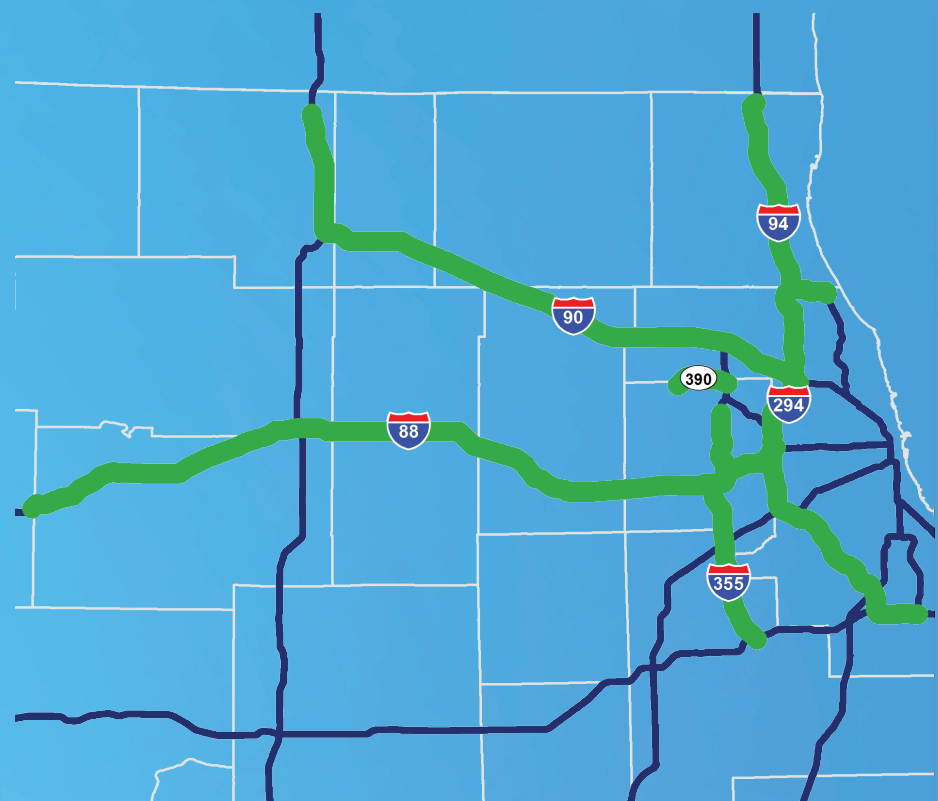



SECTION 1

The Illinois Tollway System

General Information 1-2

TABULATIONS

TABLE	PAGE
1-A Systemwide Average Daily Traffic Data	1-7
1-B Annual Traffic Totals	1-8
1-C Average Daily Traffic Totals	1-8
1-D Systemwide Monthly Factors	1-8
1-E Annual Transactions by Vehicle 2016-2018	1-9
1-F I-PASS Participation Rate 2016-2018	1-9
1-G History of Tollway Additions by Mileage 1959 - 2018	1-10
1-H History of Tollway Additions by Location 1959 - 2018	1-11
1-I Summary of Traffic Characteristics at Plazas (Annual Transactions)	1-14

ILLUSTRATIONS

FIGURE	PAGE
1-A The Illinois Tollway System 2018	1-16
1-B Average Annual Daily Traffic 2018	1-17
1-C Average Annual Daily Traffic 1960	1-18
1-D Annual Average Percentage Change in Daily Traffic Volumes 2000 - 2018	1-19
1-E Annual Average Percentage Change in Daily Traffic Volumes 2010 - 2018	1-20
1-F Major Tollway Construction Projects During 2018	1-21
1-G Major Off-Tollway Construction Projects During 2018	1-22

GENERAL INFORMATION

The 2018 Traffic Data Report is intended to provide a snapshot of the average traffic conditions throughout the Tollway system for the year 2018. The primary sources of information for the development of this report are:

- Toll plaza transaction data
- Non-tolled ramp sample traffic counts
- Physical configuration of the Tollway system and connections to other routes
- Historical traffic data for the Tollway system.

The traffic volumes presented in this report for each link of the system are primarily based on toll plaza transaction data. The data were extracted from the Electronic Transaction Consultants' Traffic Activity by Class Report and Hourly Traffic Volume Report run on January 21, 2019. Since transaction data is essentially continuous, accurate annual average daily traffic (AADT) and peak hour traffic volumes may be determined at mainline toll plazas and at tolled ramps. To obtain AADT and peak volumes in intermediate mainline segments and on non-tolled ramps, transaction data is supplemented by sample traffic counts conducted at non-tolled ramps. These sample counts are converted to AADT and peak volumes using seasonal adjustment factors and a balancing algorithm that adjusts non-toll ramp counts so that all mainline volumes are consistent with ramp exiting and entering volumes. The AADT and peak traffic estimates are then validated using historical trends and data.

Conditions influencing local traffic flow frequently cause traffic volumes to vary from historical trends. While major traffic incidents or weather events can have a significant impact on the traffic on a particular day, use of annual averages tends to diminish these types of impacts. On the other hand, some events can have an effect on typical traffic volumes on a long-term basis. One such event was the passenger car toll rate change that took effect in 2012.

In 2011, the Tollway approved the \$12 billion Move Illinois capital program. To fund the program, passenger car rates were increased 87.5 percent on January 1, 2012 for both cash and I-PASS users. Systemwide, passenger car transactions declined 4.2 percent from 2011, largely due to the toll increase. Since then, passenger car transactions have increased by an average of 3.8 percent per year.

Any reconfiguration of the Tollway system, such as a new interchange or major capacity improvement, will have a permanent impact on traffic patterns. In July 2016, the Tollway began operating the Illinois Route 390 Tollway. Formerly an Illinois Department of Transportation (IDOT) route called the Elgin-O'Hare Expressway, the highway was improved by the Tollway starting in 2014. Illinois Route 390 initially connected U.S. 20/Lake Street in Hanover Park on the west with I-290/IL 53 in Itasca on the east. In November 2017, the eastern section of the route opened on the former Thorndale Avenue, moving the eastern end to Busse Road (IL 83) in Bensenville. The route is primarily used by commuters and will eventually terminate at a proposed western bypass of O'Hare International Airport .

Major construction projects extending over many months also affect traffic volumes, causing a reduction in average traffic volumes on that route and increases in volumes on parallel routes. Most notably, traffic on the eastern Jane Addams Memorial Tollway dropped while undergoing major construction in 2015 and 2016 before rebounding in 2017 and 2018. Sections of the Illinois Tollway that were under significant construction in 2018 include:

ILLINOIS TOLLWAY SYSTEM

- Jane Addams Memorial Tollway (I-90/39)
 - New Ramp Construction – Roselle Road/Central Avenue
 - Interchange Construction – I-490
- Tri-State Tollway (I-94/294)
 - Bridge Reconstruction – Bradley Road
 - Roadway and Ramp Repairs – Half Day Road to Wisconsin State Line
 - Roadway Reconstruction – Pfingsten Road to Edens Expressway
 - Roadway and Ramp Repairs – Balmoral Avenue to Lake Cook Road
 - Roadway Reconstruction – O'Hare Oasis to Balmoral Avenue
 - Overhead Bridge Repairs – Cermak Road to 5th Avenue
 - Bridge Repairs – Mile Long Bridge
 - Shoulder Reconstruction – Plazas 35, 36, and 39
 - Interchange Reconstruction – 159th Street
- Reagan Memorial Tollway (I-88)
 - Roadway Resurfacing, Ramp and Bridge Repairs – IL 251 to IL 56
 - Ramp Reconstruction – Orchard Road
 - Roadway Repairs – Washington Street to I-88/I-355 Connector
 - Roadway Reconstruction – York Road to I-290
- Veterans Memorial Tollway (I-355)
 - Roadway Repairs – I-80 to I-55
 - Resurfacing and Bridge Repairs – I-55 to Army Trail Road
 - Roadway Widening – Butterfield Road to Roosevelt Road
- Illinois Route 390 Tollway (IL 390)
 - New Construction – Illinois 83 to York Road

Off-system construction projects in the Tollway service area, particularly those on the expressway system, can also have a significant impact on Tollway traffic volumes. During 2016, construction projects with the potential to impact traffic on the Tollway system included the following:

IDOT EXPRESSWAY SYSTEM

- I-90 – Add Lane and Cumberland Flyover Ramp Construction – I-190 to Harlem Avenue
- I-290 & I-90/94 – Jane Byrne Interchange – I-90/94 at I-290
- I-290 – Bridge Replacement – Salt Creek
- I-55 – Interchange Reconstruction – Weber Road

ARTERIALS

- US 20 Business – Add Westbound Lane – I-90 ramp to Bell School Road
- IL 132 – Roadway Rehabilitation – I-94 to IL 131
- US 20 – Roadway Rehabilitation – Shales Parkway to North Avenue

The listed projects may have caused variations in traffic patterns affecting Tollway traffic to varying degrees and may be positive or negative. These impacts are not individually quantified, but serve to illustrate the need for the reader to be cautious when using average daily or peak hour volumes from a single year.



TRAFFIC DEFINITIONS AS USED HEREIN

Traffic volumes are balanced over the entire system so that mainline and ramp volumes are consistent along a route; therefore the listed volumes are a precise numerical average only in locations where there is a toll plaza and complete data is available. Three types of traffic volumes are provided in this report and are defined below.

Annual Average Daily Traffic (AADT) Volume -- is an approximation of the numerical average daily traffic volume for each day of 2018.

AM Peak Hour Volume -- is an approximation of the 85th percentile hourly traffic volume in the highest AM hours (6:00-8:00 AM) on all Mondays through Thursdays in 2018, excluding holidays.

PM Peak Hour Volume -- is an approximation of the 85th percentile hourly traffic volume in the highest PM hours (4:00-6:00 PM) on all Mondays through Thursdays in 2018, excluding holidays.

Weekends – consist of Fridays, Saturdays, and Sundays that do not fall on holidays.

ROADWAY PERFORMANCE MEASURES

Roadway performance measures are used to illustrate congestion on the Illinois Tollway system. Performance measures are tabulated for all weekdays, Monday through Friday, including holidays. AM and PM peak hours are defined as 6:00-9:00 AM and 4:00-7:00 PM, respectively, for roadway performance measures. With the exception of the newly opened eastern section of IL 390, for which INRIX data is unavailable, calculations use travel time data purchased from INRIX. INRIX obtains speed and location data from a variety of Global Positioning System (GPS) devices, such as smart phone apps and in-vehicle navigation systems. The 5-minute INRIX raw data and is aggregated it to 15-minute or 1-hour intervals for this report. Previously, roadway performance measures were calculated using travel times from I-PASS transaction data aggregated to the one-hour level. Roadway performance measure terms are defined below.

Average Travel Time Index – is the ratio of the average peak period travel time to an off-peak travel time (assumed to have a free-flow speed of 60 mph). For example, a value of 1.20 means that average peak travel times are 20% longer than off-peak (free-flow) travel times.

Planning Time Index – is the ratio of the total time needed to ensure 95% on-time arrival as compared to a free-flow travel time. For example, a value of 1.20 means that a traveler should budget an additional 4 minute buffer for a 20-minute average peak trip time to ensure 95% on-time arrival.

Total Delay – is a ratio of additional travel time spent by drivers, above the travel times required under free-flow conditions, to vehicle-miles traveled (measured in vehicle-hours/1,000 VMT).

Vehicle-Miles Traveled (VMT) – is the sum of distances traveled by all motor vehicles within a section of the Illinois Tollway.

Average Daily Delay – is the additional travel time spent by drivers, above the travel times required under free-flow conditions (measured in vehicle-hours).

Percent Congested Travel – is the ratio of congested vehicle-miles-traveled to total vehicle-miles-traveled. Congestion is defined as any one-hour time period in which the actual travel time is greater than the free-flow travel time.

The Tollway system is divided into twelve sections for reporting performance measures. They are described in the table below.

Section	Route Designation	Beginning Milepost	Ending Milepost
Eastern Jane Addams Memorial Tollway	I-90	54.6	79.1
Western Jane Addams Memorial Tollway	I-90/I-39	2.7	54.6
Northern Tri-State Tollway	I-94	1.2	30.0
North Central Tri-State Tollway	I-294	40.7	52.8
South Central Tri-State Tollway	I-294	24.1	40.7
Southern Tri-State Tollway	I-294	0.0	24.1
Eastern Reagan Memorial Tollway	I-88	116.8	140.4
Western Reagan Memorial Tollway	I-88	44.2	116.8
Northern Veterans Memorial Tollway	I-355	22.6	29.8
Central Veterans Memorial Tollway	I-355	12.3	22.6
Southern Veterans Memorial Tollway	I-355	0.0	12.3
Illinois Route 390 Tollway	IL 390	6.0	15.8

OTHER DEFINITIONS

30th Hourly Volume (30th HV) – is the 30th highest hourly volume occurring at a plaza during 2018 regardless of day or time.

PC – Passenger Cars. Motorcycles and two-axle, four wheeled vehicles are considered passenger cars.

CV – Commercial Vehicles. All vehicles with more than four wheels, including passenger cars towing trailers are considered commercial vehicles.

HOLIDAYS AND DAYS WITH UNCHARACTERISTIC TRAFFIC PATTERNS

Due to differing traffic patterns, major holidays are classified separately from weekdays and weekends. Additionally, the day immediately preceding some holidays are considered holidays for the purpose of this report due to their unusual traffic characteristics.

Below is a list of holidays and their dates in 2018.

New Years	Monday, January 1
Memorial Day	Friday, May 25
	Monday, May 28
Independence Day	Wednesday, July 4
Labor Day	Friday, August 31
	Monday, September 3
Thanksgiving	Wednesday, November 21
	Thursday, November 22
	Friday, November 23
Christmas Eve	Monday, December 24
Christmas	Tuesday, December 25
New Year's Eve	Monday, December 31



TABLE 1-A: SYSTEM WIDE AVERAGE DAILY TRAFFIC DATA

Year	Average Daily Total			Average Trip
	Vehicles	Vehicle Miles	Transactions	Length (miles)
1959	62,321	1,753,465	117,637	28.14
1960	87,358	2,346,638	160,973	26.86
1961	109,731	2,659,991	194,577	24.24
1962	132,668	2,985,415	222,322	22.50
1963	134,818	2,878,143	211,939	21.35
1964	138,876	2,971,427	217,831	21.40
1965	158,170	3,303,069	247,469	20.88
1966	172,263	3,705,230	283,152	21.51
1967	186,379	3,973,250	313,648	21.32
1968	206,449	4,376,634	368,342	21.20
1969	238,245	4,821,981	440,997	20.24
1970	254,586	5,180,119	485,214	20.35
1971	279,326	5,669,283	533,241	20.30
1972	303,014	5,892,861	561,173	19.45
1973	342,322	6,353,650	621,905	18.56
1974	349,315	6,450,658	637,824	18.47
1975	369,435	6,780,810	666,002	18.35
1976	404,502	7,356,671	723,102	18.19
1977	431,215	7,850,792	770,872	18.21
1978	465,613	8,392,536	824,085	18.02
1979	479,525	8,685,523	851,116	18.11
1980	472,518	8,578,161	842,742	18.15
1981	493,226	8,846,114	866,299	17.94
1982	500,961	8,820,131	869,866	17.61
1983	527,505	9,273,782	906,308	17.58
1984	544,532	9,779,084	958,999	17.96
1985	587,614	10,283,396	1,008,812	17.50
1986	629,278	11,295,635	1,102,413	17.95
1987	672,160	11,689,569	1,172,861	17.39
1988	721,177	12,902,373	1,269,782	17.89
1989	745,381	13,323,423	1,307,767	17.87
1990	896,699	14,672,385	1,487,801	16.36
1991	946,112	14,913,846	1,547,094	15.76
1992	993,920	15,290,401	1,572,740	15.38
1993	1,034,054	15,612,752	1,607,475	15.10
1994	1,041,362	17,231,387	1,732,312	16.55
1995	1,088,510	18,271,480	1,827,959	16.79
1996	1,123,270	18,878,017	1,890,858	16.81
1997	1,193,230	19,316,298	1,941,011	16.19
1998	1,218,030	19,550,833	1,984,130	16.05
1999	1,247,410	20,374,456	1,972,261	16.33
2000	1,277,940	20,647,836	2,011,583	16.16
2001	1,322,130	21,431,414	2,088,631	16.21
2002	1,337,005	22,274,640	2,153,241	16.66
2003	1,363,990	22,791,808	2,196,240	16.71
2004	1,404,110	23,382,734	2,249,030	16.65
2005	1,344,410	22,381,137	2,138,209	16.65
2006	1,333,990	22,184,397	2,093,494	16.63
2007	1,412,430	22,775,523	2,159,704	16.13
2008	1,382,450	22,005,034	2,125,361	15.92
2009	1,381,050	21,951,844	2,124,254	15.90
2010	1,402,290	23,363,833	2,238,582	16.66
2011	1,422,040	23,713,815	2,287,292	16.68
2012	1,379,220	22,776,184	2,196,121	16.51
2013	1,401,090	23,251,182	2,235,730	16.60
2014	1,420,440	23,741,315	2,296,656	16.71
2015	1,475,930	25,006,490	2,415,385	16.94
2016	1,575,670	25,905,518	2,618,430	16.44
2017	1,654,440	26,821,587	2,781,408	16.21
2018	1,632,430	26,447,503	2,764,251	16.20

TABLE 1-B: ANNUAL TRAFFIC TOTALS

Tollway Route	Vehicles	Vehicle Miles			Transactions
		PC	CV	Total	
Jane Addams Memorial	130,020,300	2,032,853,368	368,984,237	2,401,837,605	212,898,841
Tri-State	240,308,700	3,587,757,605	687,179,700	4,274,937,305	412,810,836
Reagan Memorial	90,987,200	1,545,195,974	215,773,536	1,760,969,510	144,897,204
Veterans Memorial	97,969,650	963,118,856	113,441,344	1,076,560,200	161,593,001
Illinois Route 390	36,551,100	127,220,613	11,813,362	139,033,975	76,751,764
Total	595,836,950	8,256,146,416	1,397,192,179	9,653,338,595	1,008,951,646

TABLE 1-C: AVERAGE DAILY TRAFFIC TOTALS

Tollway Route	Vehicles	Vehicle Miles			Transactions
		PC	CV	Total	
Jane Addams Memorial	356,220	5,569,461	1,010,916	6,580,377	583,284
Tri-State	658,380	9,829,473	1,882,684	11,712,157	1,130,989
Reagan Memorial	249,280	4,233,414	591,160	4,824,574	396,979
Veterans Memorial	268,410	2,638,682	310,798	2,949,480	442,721
Illinois Route 390	100,140	348,550	32,365	380,915	210,279
Total	1,632,430	22,619,579	3,827,924	26,447,503	2,764,251

TABLE 1-D: SYSTEMWIDE MONTHLY FACTORS

Month	Factor
January	0.91
February	0.91
March	1.00
April	1.01
May	1.06
June	1.08
July	1.05
August	1.06
September	1.00
October	1.02
November	0.97
December	0.94



TABLE 1-E: ANNUAL TRANSACTIONS BY VEHICLE 2017-2018

Tollway Route	Passenger Vehicles		Commercial Vehicles		% CV	
	2017	2018	2017	2018	2017	2018
Jane Addams Memorial	176,759,929	188,584,347	22,477,967	24,314,494	11.3%	11.4%
Tri-State	357,393,381	350,854,120	59,596,768	61,956,716	14.3%	15.0%
Reagan Memorial	140,759,555	132,607,208	13,308,630	12,289,996	8.6%	8.5%
Veterans Memorial	157,765,732	147,410,423	14,401,794	14,182,578	8.4%	8.8%
Illinois Route 390	50,789,522	69,727,438	4,080,458	7,024,326	7.4%	9.2%
Total	883,468,119	889,183,536	113,865,617	119,768,110	11.4%	11.9%

TABLE 1-F: I-PASS PARTICIPATION RATE

Tollway Route	2018
Jane Addams Memorial	89.5%
Tri-State	87.5%
Reagan Memorial	91.6%
Veterans Memorial	94.2%
Illinois Route 390	95.7%
Total	90.2%

TABLE 1-G: HISTORY OF TOLLWAY ADDITIONS BY MILEAGE 1959 - 2018

Year	Mainline Lane - Miles	Ramp Lane - Miles	Total Lane - Miles
1959	811	88	899
1960	812	88	900
1963	812	89	901
1966	822	92	914
1967	839	93	932
1970	839	94	933
1971	839	96	935
1972	840	97	937
1973	856	98	954
1974	1,154	109	1,263
1975	1,176	110	1,286
1976	1,200	110	1,310
1977	1,222	110	1,332
1979	1,235	110	1,345
1982	1,235	115	1,350
1983	1,235	115	1,350
1984	1,237	117	1,354
1986	1,237	118	1,355
1987	1,249	118	1,367
1988	1,249	119	1,368
1989	1,342	154	1,496
1990	1,342	156	1,498
1991	1,342	157	1,499
1992	1,354	159	1,513
1993	1,413	159	1,572
1994	1,417	164	1,581
1995	1,417	167	1,584
1996	1,427	169	1,596
1997	1,428	175	1,603
1998	1,444	179	1,623
1999	1,459	181	1,641
2000	1,467	183	1,649
2001	1,469	184	1,653
2002	1,470	184	1,654
2003	1,473	184	1,657
2004	1,477	185	1,662
2005	1,484	186	1,670
2006	1,501	186	1,687
2007	1,575	210	1,785
2008	1,599	267	1,866
2009	1,741	305	2,046
2010	1,741	305	2,046
2011	1,741	305	2,046
2012	1,744	305	2,049
2013	1,744	309	2,053
2014	1,816	316	2,132
2015	1,816	322	2,138
2016	1,919	340	2,259
2017	1,965	317	2,281
2018	1,945	333	2,278

Lane miles are provided by WSP USA

Lane designations may sometimes be changed from mainline or ramp or ramp to mainline.

TABLE 1-H: HISTORY OF TOLLWAY ADDITIONS BY LOCATION 1959 — 2018

Year	Mainline Lane Miles	Ramp Lane Miles	Additions
1959	811	88	Original Tollway (First full year of operation)
1960	812	88	Tri-State Tollway & Jane Addams Memorial Tollway widened (3rd Lane) at O'Hare Airport
1963	812	88.5	Tri-State Tollway Willow Road Interchange (2 Ramps)
1966	822	91.5	Tri-State Tollway widened (3rd Lane) in both directions MP 0.0 to MP 5.0; I-80 Interchange added (3 Ramp-Miles)
1967	839	92.5	Jane Addams Memorial Tollway widened (3rd Lane) in both directions MP 2.5 to MP 11.0; Tri-State Tollway Lincoln Oasis ramps addition (4 Ramps)
1970	839	94	Jane Addams Memorial Tollway Arlington Heights Interchange addition
1971	839	96	Tri-State Tollway Plaza 37 ramp widening; Willow Road Interchange addition
1972	840	96.5	Tri-State Tollway widened (4th Lane) MP 39.0 to MP 40.0; Jane Addams Memorial Tollway IL Route 47 Interchange addition
1973	856	98	Tri-State Tollway widened (3rd Lane) in both directions MP 16.0 to MP 24.0; Plaza 32 ramps
1974	1154	109	Reagan Memorial Tollway Extension constructed; Tri-State Tollway widened (3rd Lane) in both directions MP 44.0 to MP 49.0; Jane Addams Memorial Tollway widened (3rd Lane) MP 11.0 to MP 17.0
1975	1176	110	Jane Addams Memorial Tollway widened (3rd Lane) in both directions MP 5.0 to MP 16.0; Barrington Road Interchange
1976	1200	110	Tri-State Tollway widened (3rd Lane) in both directions MP 49.0 to MP 53.0 and MP 62.5 to MP 70.5
1977	1222	110	Reagan Memorial Tollway widened (3rd Lane) in each direction MP 145.0 to 156.0
1979	1235	110	Tri-State Tollway widened (3rd Lane) in both directions MP 70.5 to MP 77.0
1982	1235	114.5	Reagan Memorial Tollway U.S. Route 51 Interchange & IL Route 59 Interchange ramps; Tri-State Tollway Hinsdale Oasis ramps, Plaza 37 extended & widened
1984	1237	117	Jane Addams Memorial Tollway widened (4th Lane) westbound MP 1.2 to MP 2.5 & Roselle Road Interchange ramps; Tri-State Tollway widened (4th Lane) northbound MP 41.5 to MP 42.5
1986	1237	117.5	Reagan Memorial Tollway Naperville Road Interchange (1 Ramp added)
1987	1249	118	Reagan Memorial Tollway widened (3rd Lane) in both directions MP 123.5 to MP 129.5; Jane Addams Memorial Tollway East Riverside Boulevard Interchange ramp
1988	1249	119	Reagan Memorial Tollway Orchard Road Interchange
1989	1342	154	Veterans Memorial Tollway Opened; Tri-State Tollway 95th Street Interchange (2 additional ramps) & IL Route 60 Interchange (2 additional ramps); Jane Addams Memorial Tollway East Riverside Boulevard Interchange (2 additional ramps)
1990	1342	155.5	Tri-State Tollway Lake Cook Road Interchange (2 ramps added); Jane Addams Memorial Tollway Randall Road Interchange (2 ramps added)
1991	1342	157	Tri-State Tollway 159th Street Interchange (4 ramps added)
1992	1354	158.5	Reagan Memorial Tollway IL Route 59 Interchange (4 ramps added); Jane Addams Memorial Tollway widened in both directions MP 16.6 to MP 22.6; Tri-State Tollway Plaza 32 to River Road ramp
1993	1412.5	159	Tri-State Tollway widened in both directions 95th Street to I-190; Balmoral Avenue Interchange (1 ramp added)
1994	1416.6	164.3	Tri-State Tollway 75th Street Interchange; Reagan Memorial Tollway Winfield Road Interchange; Jane Addams Memorial Tollway Beverly Road Interchange; Veterans Memorial Tollway widened (3rd Lane) MP 14.4 to MP 18.5

2017 and 2018 lane miles provided by WSP USA.

Prior year values taken from AECOM 2016 Consulting Engineer's Annual Report, Appendix I: Tollway System Expansion History. (cont'd)



TABLE 1-H: HISTORY OF TOLLWAY ADDITIONS BY LOCATION 1959 — 2018

Year	Mainline Lane Miles	Ramp Lane Miles	Additions
1995	1416.6	167.3	Tri-State Tollway Lake Cook Road Exit Ramp, Southbound Buckley Road (Route 137) Interchange; Jane Addams Memorial Tollway Rockton Road Interchange
1997	1428.2	175.2	Veterans Memorial Tollway widened (3rd Lane) in both directions MP 22.6 to MP 27.9; Jane Addams Memorial Tollway Randall Road Interchange, Barrington Road & Roselle Road Interchange Plazas w/ additional westbound lane; Tri-State Tollway IL Route 137 Interchange expansion; Reagan Memorial Tollway Orchard Road Interchange
1998	1443.5	179.1	Reagan Memorial Tollway widened MP 118.7 (Plaza 61 – Aurora) to MP 123.5 (IL Route 59); Edens Spur Plaza 24 (Edens Spur); Jane Addams Memorial Tollway Fox River & Plaza 9 (Elgin) widening MP 21.75 to MP 22.0; U.S. Route 20 Bypass exit lane added; Reagan Memorial Tollway Peace Road Interchange (2 ramps added); Tri-State Tollway Willow Road Interchange (2 ramps added); Golf Road Interchange Plaza 28 lanes; Veterans Memorial Tollway 63rd Street interchange Plaza 85 widening; Ogden Avenue Interchange Plaza 81 widening
1999	1459.4	181.1	Veterans Memorial Tollway Plaza 73 (Army Trail Road); Boughton Road Interchange and Plaza expansion; Jane Addams Memorial Tollway I-290/Route 53 Interchange & Plaza 15 expansion; Tri-State Tollway widened (4th Lane) northbound from Edens Spur to Half Day Road
2000	1466.8	182.6	Reagan Memorial Tollway Plaza 61 (Aurora) I-PASS Express expansion MP 117.6 to MP 118.2; Tri-State Tollway widened (4th Lane) southbound from Half Day Road to Edens Spur Split and additional southbound exit ramp length to Lake Cook Road (MP 52.9 to MP 56.4); Tri-State Tollway Plaza 41 (163rd Street) I-PASS only lanes & increased ramp tapers to 159th Street Interchange MP 5.0 to MP 6.5
2001	1468.6	183.9	Tri-State Tollway widened from Plaza 36 (82nd Street) to 95th Street (MP 18.0 to MP 19.8); Deerfield Road northbound exit ramp added from Edens Spur and northbound entrance ramp added from Lake Cook Road (MP 52.9); Grand Avenue Interchange ramp added (MP 69.8)
2002	1469.6	183.9	Reagan Memorial Tollway Plaza 61 (Aurora) reconfigure for additional I-PASS Express Lane eastbound (MP 117.6 to MP 118.2); Tri-State Tollway Plaza 29 (Touhy) additional I-PASS Only Lane northbound (MP 41.8)
2003	1473.3	183.9	Jane Addams Memorial Tollway Plaza 19 (River Road) additional I-PASS Only Lanes (MP 0.6); Plaza 17 (Devon Avenue) additional I-PASS Only Lanes (MP 1.7); Reagan Memorial Tollway Plaza 51 (York Road) westbound convert shoulder to increase I-PASS Only Lane taper (MP 138.2)
2004	1477.2	185.1	Jane Addams Memorial Tollway Route 31 Interchange additional ramp lane at Plaza 11 (MP 24.1); Plaza 9 (Elgin) additional lane in both directions (MP 25.0); Reagan Memorial Tollway Farnsworth Avenue Interchange additional ramp lane at Plaza 59 (MP 19.3); Plaza 51 (York Road) converted shoulder eastbound on both sides of plaza (MP 138.2); Veterans Memorial Tollway widened northbound from Maple Avenue to Ogden Avenue (MP 18.3 to MP 19.5); I-55 Interchange (southbound exit to southbound I-55) additional ramp lane (MP 12.3)

2017 and 2018 lane miles provided by WSP USA.

(cont'd)

Prior year values taken from AECOM 2016 Consulting Engineer's Annual Report, Appendix I: Tollway System Expansion History.

TABLE 1-H: HISTORY OF TOLLWAY ADDITIONS BY LOCATION 1959 — 2018

Year	Mainline Lane Miles	Ramp Lane Miles	Additions
2005	1484	185.5	Reagan Memorial Tollway widened in both directions from MP 123.3 to MP 126.7; Jane Addams Memorial Tollway Randall Road Interchange additional ramp lane (MP 26.6)
2006	1488.6	185.5	Tri-State Tollway widened in both directions from IL Route 394 to Halsted Street; ORT projects removed I-PASS auxiliary lanes
2007	1562.4	209.7	Veterans Memorial Tollway South Extension Added; Jane Addams Memorial Tollway IL Route 173 Interchange (MP 79.3) ramps added
2008	1586.8	209.7	Veterans Memorial Tollway widened northbound from 75th Street (MP 15.5) to Ogden Avenue (MP 19.5); Reagan Memorial widened in both directions from Washington Street (MP 126.6) to Finley Road (MP 132.0); Tri-State Tollway widened in both directions from Stearns School Road (MP 70.8) to IL Route 173 (MP 75.7)
2009	1741.2	305.5	Veteran's Memorial Tollway widened southbound from 75th Street (MP 15.5) to Ogden Avenue (MP 19.5); Reagan Memorial Tollway widened in both directions from Finley Road (MP 132.0) to IL Route 83 (MP 137.1); Tri-State Tollway widened in both directions from 163rd Street (MP 6.0) to 95th Street (MP 17.6) and from Balmoral Avenue (MP 40.0) to Stearns School Road (MP 70.8); Jane Addams Memorial Tollway widened in both directions from Newburg Road (MP 61.4) to Rockton Road (MP 75.5); Irene Road Interchange westbound exit ramp added
2010	1741.4	304.4	Reagan Memorial Tollway Farnsworth Interchange Ramp "A" widened at Plaza 59 for IPO Lane (MP 119.2); System mapping of lane miles updated to field quantity
2011	1741.4	305	Tri-State Tollway Balmoral Interchange (MP 39.8) exit ramp from northbound I-294 added
2012	1743.9	305	Reagan Memorial Tollway (I-88) Roadway Reconstruction and Widening (MP 113.4 to MP 115.8)
2013	1743.9	308.7	Jane Addams Memorial Tollway reconfigured Illinois Route 47 Interchange opened
2014	1816.1	316.3	Reconstruction of the Jane Addams Memorial Tollway (I-90); Construction of the Tri-State (I-294) & Interstate 57 Interchange
2015	1816.4	321.8	Jane Addams Memorial Tollway Irene Road ramp construction, Genoa Road Interchange reconstruction; Tri-State Tollway reconstructed Grand Avenue (IL 132) Interchange; Reagan Memorial Tollway reconstructed IL Route 59 Interchange
2016	1918.5	340.2	Widening of the Jane Addams Memorial Tollway (I-90) from east of Elgin Plaza 9 to the eastern terminus; Widening of the existing Illinois Route 390 Tollway (IL 390) from Lake Street to Rohlwing Road; Construction of the Illinois Route 390 Tollway (IL 390) & Interstate 290 Interchange
2017	1964.9	316.5	Jane Addams Memorial Tollway Barrington Road interchange reconstruction, Roselle Road interchange reconstruction, Elmhurst Road interchange reconstruction; Illinois Route 390 Tollway eastern segment constructed from I-290 to Busse Road (IL 83)
2018	1945	332.5	Construction of the Cumberland Avenue flyover ramp (I-90).

2017 and 2018 lane miles provided by WSP USA.

Prior year values taken from AECOM 2016 Consulting Engineer's Annual Report, Appendix I: Tollway System Expansion History.

TABLE 1-I: SUMMARY OF TRAFFIC CHARACTERISTICS AT PLAZAS (Annual Transactions)

JANE ADDAMS MEMORIAL TOLLWAY

Plaza	Traffic			I-PASS Usage			
	Total (000s)	PC%	CV%	Total (000s)	Total%*	PC%	CV%
1	20,339	70.8%	29.2%	15,545	76.4%	73.6%	83.4%
2	3,191	92.6%	7.4%	2,903	91.0%	90.9%	91.8%
3	1,769	87.1%	12.9%	1,600	90.5%	90.5%	90.1%
4	2,272	89.8%	10.2%	2,083	91.7%	92.0%	88.4%
5	8,725	76.5%	23.5%	7,311	83.8%	82.3%	88.5%
5A	634	88.4%	11.6%	581	91.7%	91.6%	92.1%
6	8,504	93.5%	6.5%	8,162	96.0%	96.2%	93.3%
7	9,662	78.6%	21.4%	8,155	84.4%	83.1%	89.2%
8	2,734	91.4%	8.6%	2,516	92.0%	92.2%	89.6%
9	37,214	86.5%	13.5%	33,485	90.0%	90.1%	89.3%
10	9,997	96.7%	3.3%	9,400	94.0%	94.2%	89.9%
11	7,992	94.6%	5.4%	7,414	92.8%	93.0%	88.9%
12	9,208	97.3%	2.7%	8,702	94.5%	94.6%	89.7%
12A	2,802	97.5%	2.5%	2,619	93.4%	93.4%	93.6%
13	2,583	92.4%	7.6%	2,343	90.7%	90.5%	92.7%
14	2,256	93.1%	6.9%	2,125	94.2%	94.5%	89.8%
15	11,502	87.2%	12.8%	10,361	90.1%	90.5%	87.4%
16	5,066	92.7%	7.3%	4,715	93.1%	93.3%	90.4%
17	32,914	92.8%	7.2%	29,856	90.7%	90.7%	90.4%
18	6,136	93.7%	6.3%	5,816	94.8%	95.0%	91.7%
18A	4,979	86.2%	13.8%	4,727	94.9%	95.4%	92.1%
19	22,419	95.8%	4.2%	20,116	89.7%	89.7%	89.3%
Jane Addams Memorial Total	212,899	88.6%	11.4%	190,534	89.5%	89.7%	88.1%

TRI-STATE TOLLWAY

20	2,579	94.0%	6.0%	2,420	93.9%	94.1%	89.4%
21	28,908	80.5%	19.5%	24,761	85.7%	84.4%	90.7%
22	3,707	96.4%	3.6%	3,452	93.1%	93.3%	88.5%
23	4,095	97.0%	3.0%	3,826	93.4%	93.6%	88.8%
24	18,511	92.8%	7.2%	16,408	88.6%	88.7%	88.4%
26	6,522	95.8%	4.2%	6,101	93.5%	93.6%	91.2%
27	6,220	95.1%	4.9%	5,920	95.2%	95.3%	92.6%
28	6,536	96.8%	3.2%	6,157	94.2%	94.4%	88.8%
29	35,464	89.9%	10.1%	32,205	90.8%	90.7%	91.5%
30	4,299	94.5%	5.5%	3,963	92.2%	92.2%	92.2%
31	10,249	98.1%	1.9%	9,286	90.6%	90.7%	83.2%
32	5,849	98.3%	1.7%	5,161	88.2%	88.4%	80.8%
33	38,549	89.0%	11.0%	34,763	90.2%	90.0%	91.3%
34	2,455	57.9%	42.1%	2,273	92.6%	91.6%	93.9%
35	57,072	82.0%	18.0%	50,120	87.8%	87.3%	90.3%
36	31,548	82.7%	17.3%	27,431	87.0%	86.2%	90.4%
37	23,534	84.1%	15.9%	21,234	90.2%	90.2%	90.3%
38	6,279	83.8%	16.2%	5,361	85.4%	85.3%	85.7%
39	30,324	82.6%	17.4%	26,181	86.3%	85.5%	90.1%
40	1,968	84.7%	15.3%	1,651	83.9%	83.0%	89.0%
41	40,419	77.6%	22.4%	33,806	83.6%	81.9%	89.7%
42	14,264	86.0%	14.0%	12,631	88.6%	88.2%	90.4%
43	13,240	75.3%	24.7%	10,313	77.9%	77.0%	80.6%
45	12,150	74.1%	25.9%	9,537	78.5%	77.2%	82.1%
47	8,071	89.8%	10.2%	6,180	76.6%	75.7%	84.3%
Tri-State Total	412,811	85.0%	15.0%	361,140	87.5%	87.2%	89.3%

* Percent of total traffic

(cont'd)

TABLE 1-I: SUMMARY OF TRAFFIC CHARACTERISTICS AT PLAZAS (Annual Transactions)

REAGAN MEMORIAL TOLLWAY

Plaza	Traffic			I-PASS Usage			
	Total (000s)	PC%	CV%	Total (000s)	Total%*	PC%	CV%
51	32,087	93.4%	6.6%	29,296	91.3%	91.2%	92.4%
52	31,314	93.2%	6.8%	28,712	91.7%	91.6%	92.7%
53	3,146	97.8%	2.2%	3,003	95.5%	95.5%	92.7%
54	3,156	96.5%	3.5%	2,937	93.1%	93.1%	91.2%
55	1,608	98.3%	1.7%	1,487	92.5%	92.6%	85.6%
56	5,556	98.5%	1.5%	5,257	94.6%	94.7%	87.7%
57	4,020	97.7%	2.3%	3,824	95.1%	95.2%	91.8%
58	2,682	97.7%	2.3%	2,554	95.2%	95.4%	87.8%
59	9,627	92.2%	7.8%	8,742	90.8%	90.8%	91.3%
60	3,808	93.9%	6.1%	3,654	96.0%	96.0%	94.6%
61	29,985	90.0%	10.0%	27,678	92.3%	92.3%	92.4%
63	1,165	91.4%	8.6%	1,076	92.4%	91.9%	97.9%
64	1,323	86.4%	13.6%	1,231	93.1%	93.2%	92.4%
65	3,306	87.6%	12.4%	3,025	91.5%	91.2%	94.0%
66	5,555	73.0%	27.0%	4,782	86.1%	84.1%	91.4%
67	1,346	95.1%	4.9%	1,212	90.0%	89.9%	93.2%
69	5,214	73.7%	26.3%	4,230	81.1%	78.5%	88.6%
Reagan Memorial Total	144,897	91.5%	8.5%	132,701	91.6%	91.6%	91.9%

VETERANS MEMORIAL TOLLWAY

73	39,822	91.6%	8.4%	37,676	94.6%	94.8%	92.9%
75	10,069	85.5%	14.5%	9,452	93.9%	94.2%	91.8%
77	5,317	96.7%	3.3%	5,024	94.5%	94.7%	88.2%
79	6,253	96.6%	3.4%	5,860	93.7%	93.9%	88.5%
81	1,875	95.4%	4.6%	1,771	94.5%	94.8%	87.9%
83	4,023	96.1%	3.9%	3,865	96.1%	96.2%	93.1%
85	5,693	97.2%	2.8%	5,459	95.9%	96.1%	89.6%
87	5,559	96.8%	3.2%	5,289	95.1%	95.3%	91.2%
89	44,051	89.5%	10.5%	41,176	93.5%	93.6%	92.5%
90	4,683	96.7%	3.3%	4,361	93.1%	93.3%	88.3%
93	2,611	91.4%	8.6%	2,524	96.7%	96.9%	93.9%
95	3,865	93.8%	6.2%	3,714	96.1%	96.4%	92.2%
97	4,710	95.6%	4.4%	4,534	96.2%	96.4%	92.4%
99	21,256	86.5%	13.5%	19,845	93.4%	93.5%	92.7%
101	1,807	94.2%	5.8%	1,673	92.6%	92.7%	90.4%
Veterans Memorial Total	161,593	91.2%	8.8%	152,223	94.2%	94.4%	92.3%

ILLINOIS ROUTE 390 TOLLWAY

320	5,307	84.6%	15.4%	5,055	95.3%	95.5%	93.7%
322	8,857	85.5%	14.5%	8,463	95.5%	95.9%	93.6%
324	9,691	86.1%	13.9%	9,257	95.5%	95.9%	93.3%
325	1,630	98.2%	1.8%	1,577	96.7%	96.7%	96.0%
326	21,135	92.9%	7.1%	20,226	95.7%	95.9%	93.6%
328	20,018	93.2%	6.8%	19,176	95.8%	96.0%	93.5%
330	10,114	93.2%	6.8%	9,692	95.8%	96.0%	93.1%
Illinois Route 390 Total	76,752	90.8%	9.2%	49,094	95.7%	95.9%	93.5%
Tollway Total	1,008,952	88.1%	11.9%	885,692	90.2%	90.2%	89.9%

* Percent of total traffic

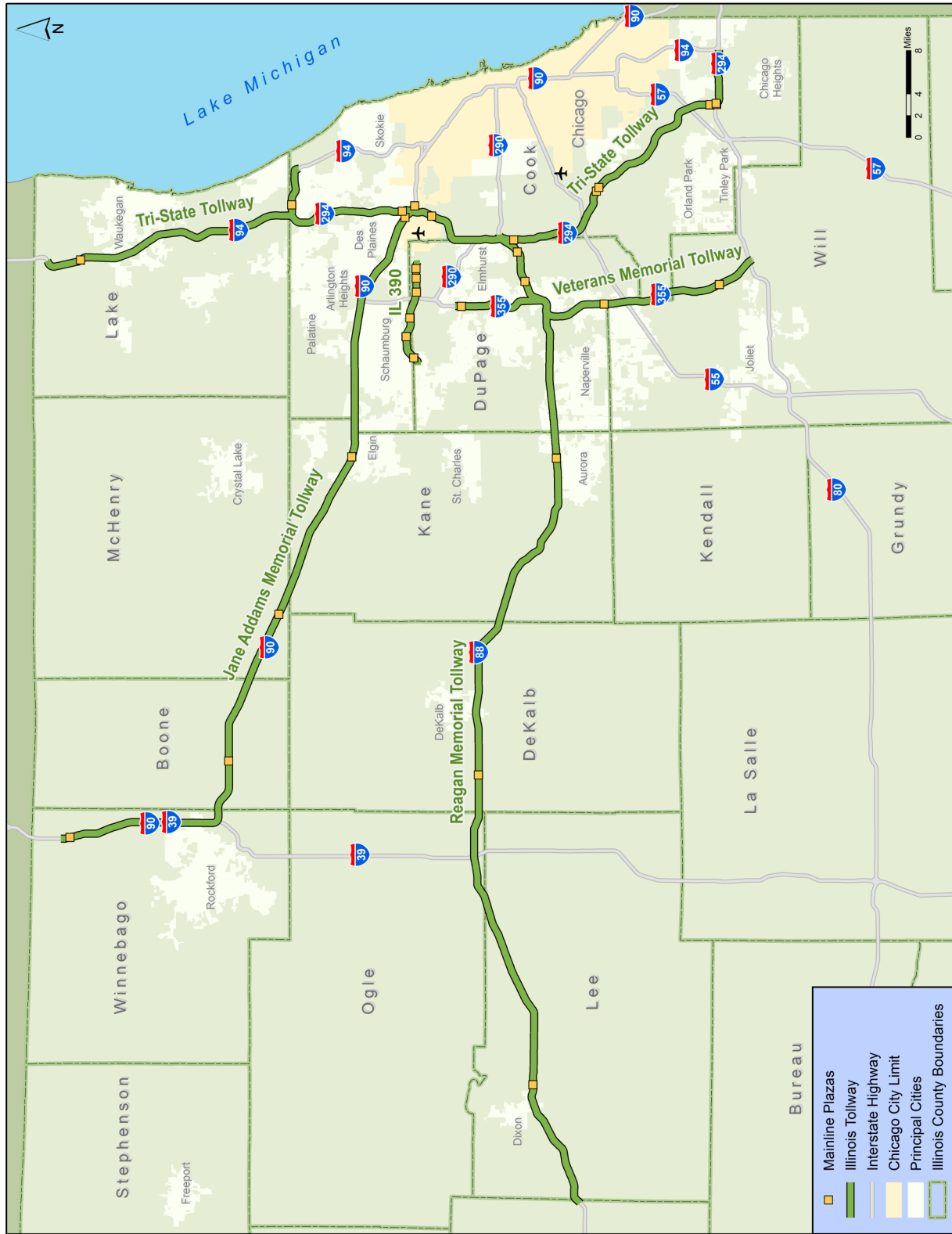

FIGURE 1-A: THE ILLINOIS TOLLWAY SYSTEM 2018

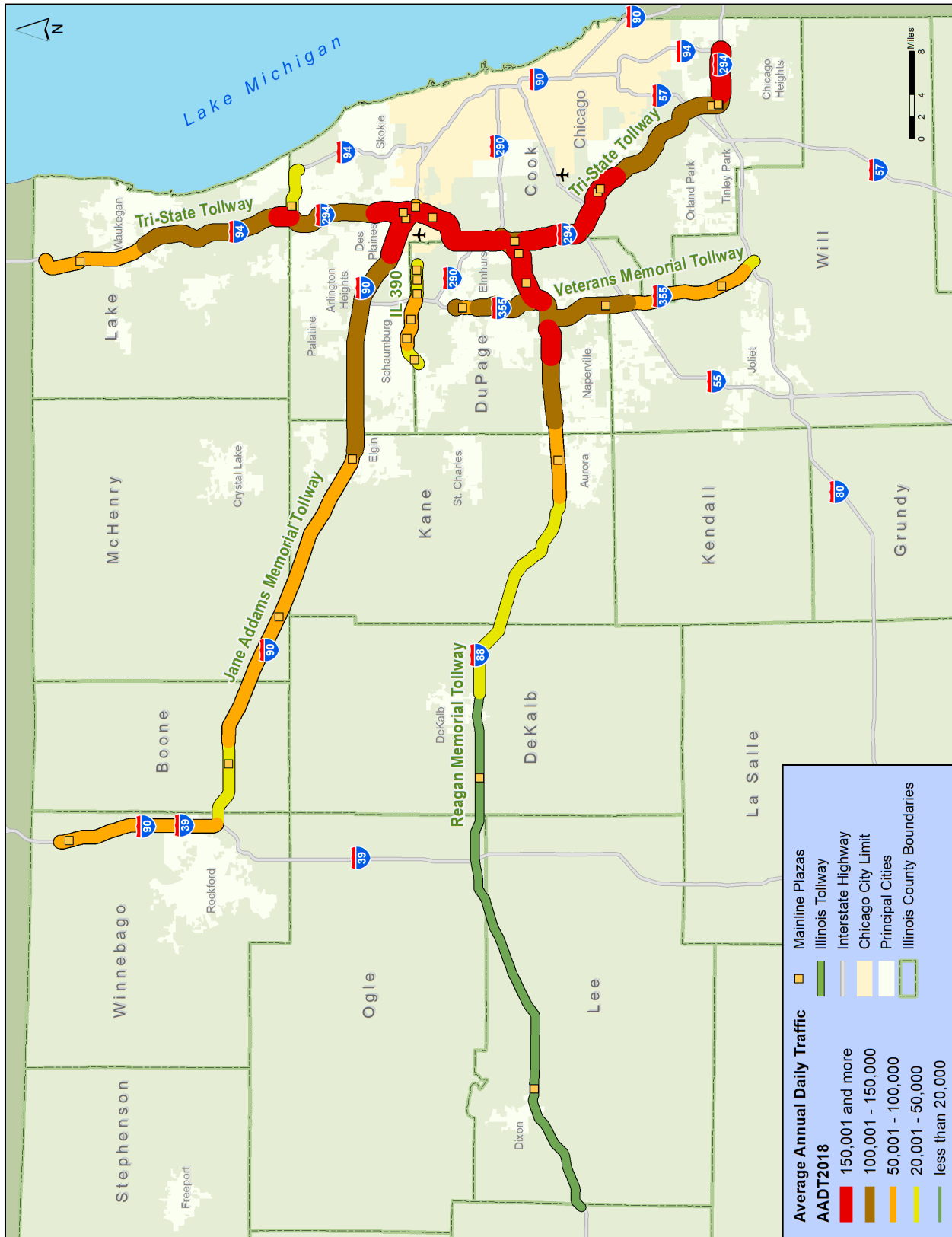

FIGURE 1-B: AVERAGE ANNUAL DAILY TRAFFIC 2018

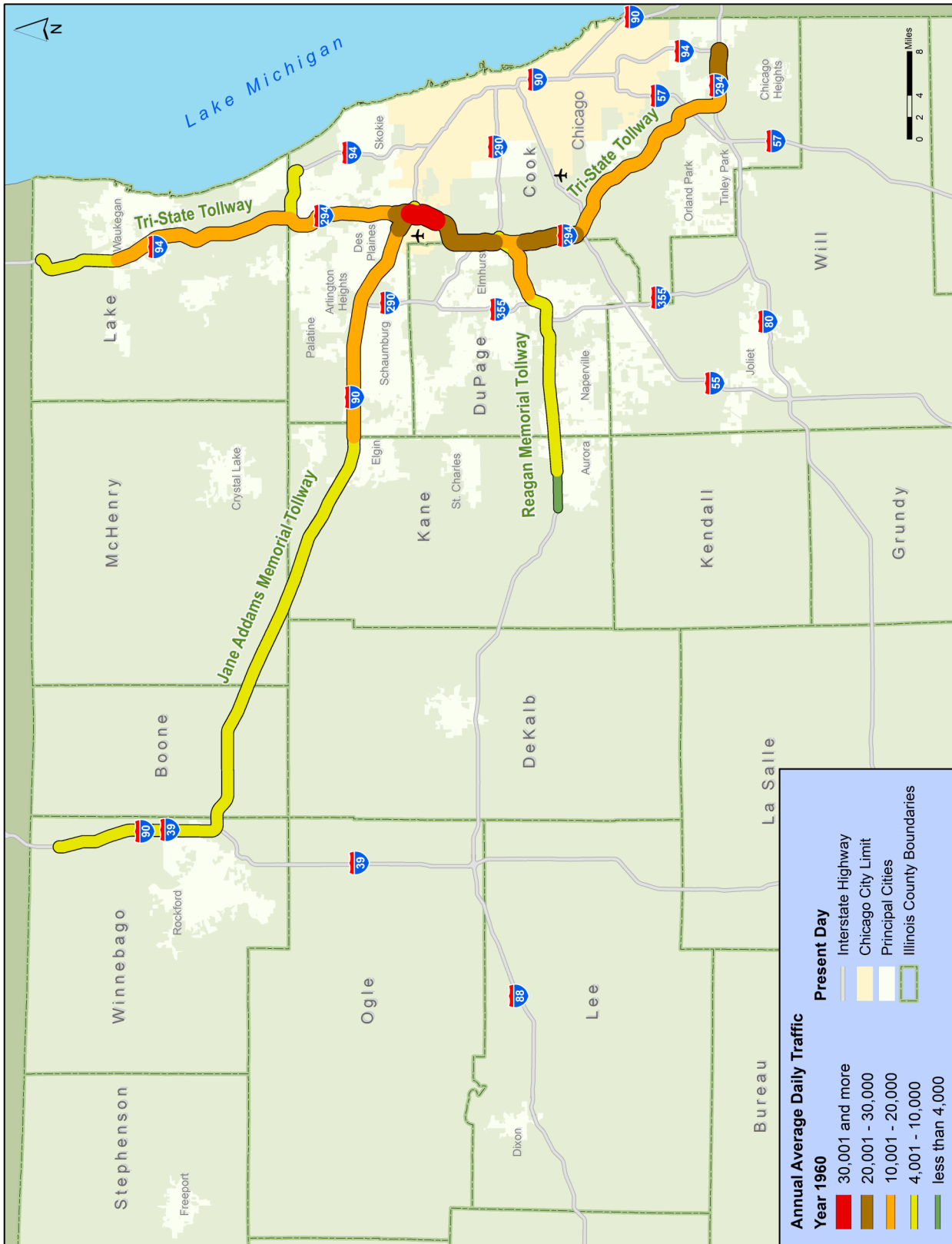

FIGURE 1-C: AVERAGE ANNUAL DAILY TRAFFIC 1960

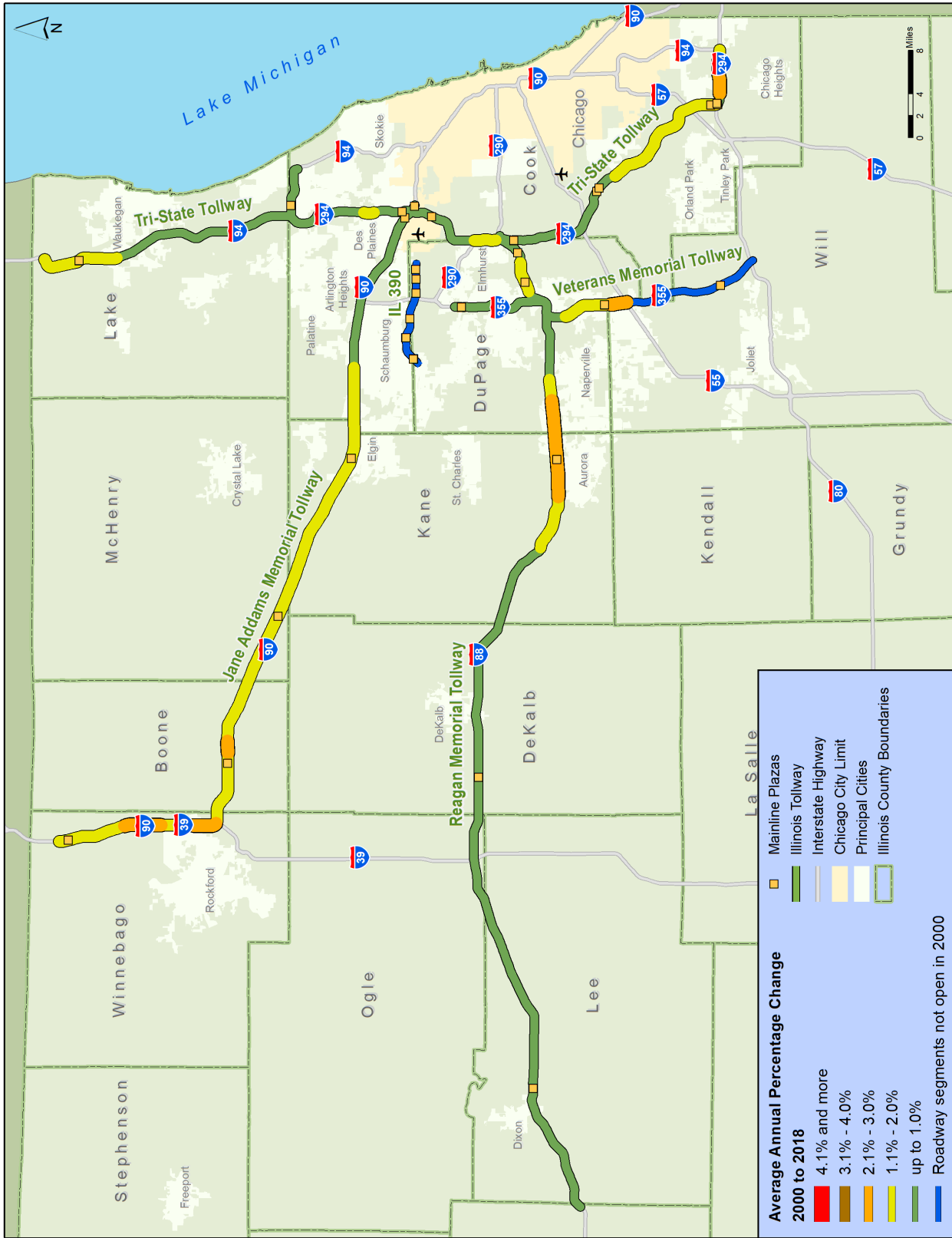

FIGURE 1-D: ANNUAL AVERAGE PERCENTAGE CHANGE IN DAILY TRAFFIC VOLUMES 2000-2018

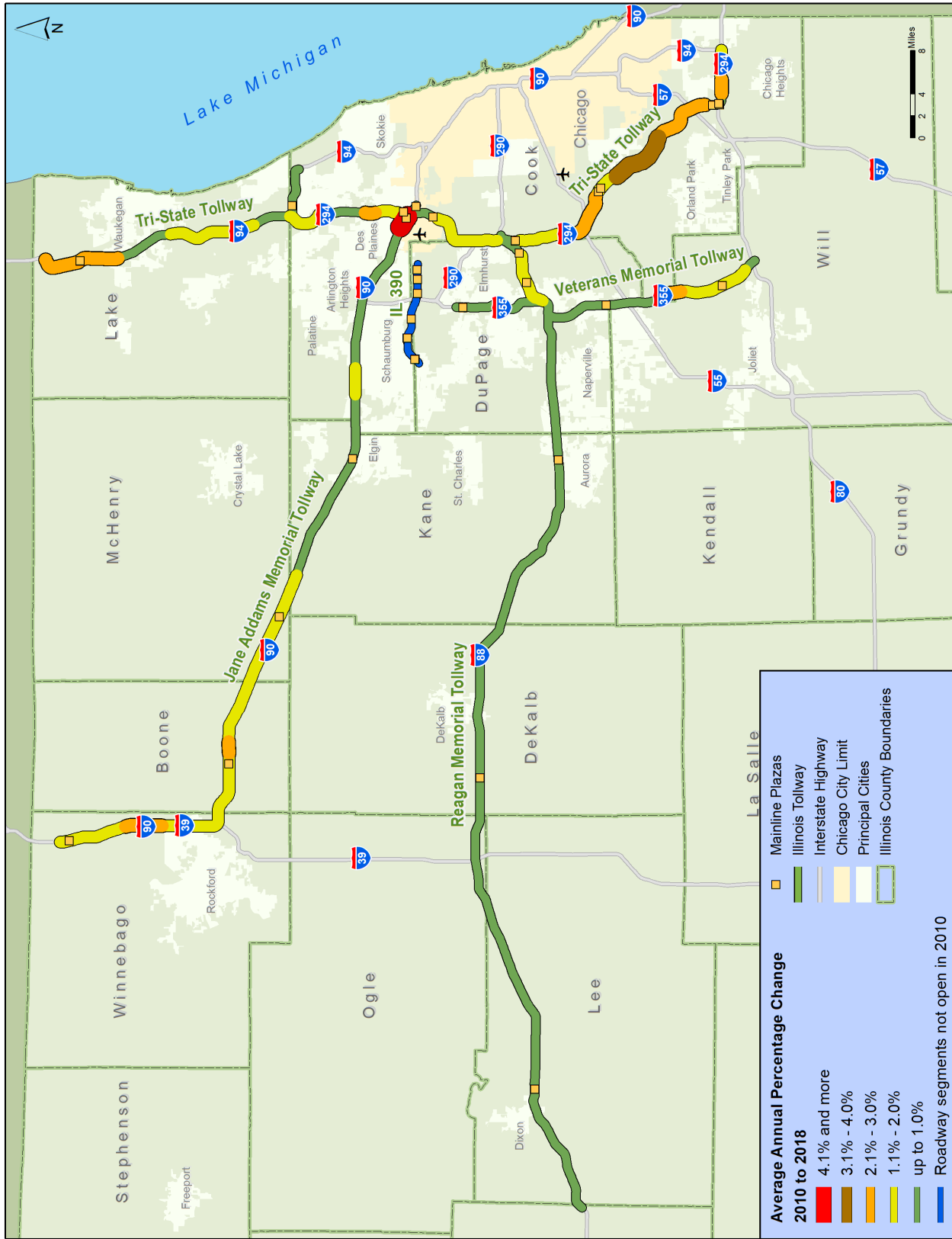

FIGURE 1-E: ANNUAL AVERAGE PERCENTAGE CHANGE IN DAILY TRAFFIC VOLUMES 2010-2018

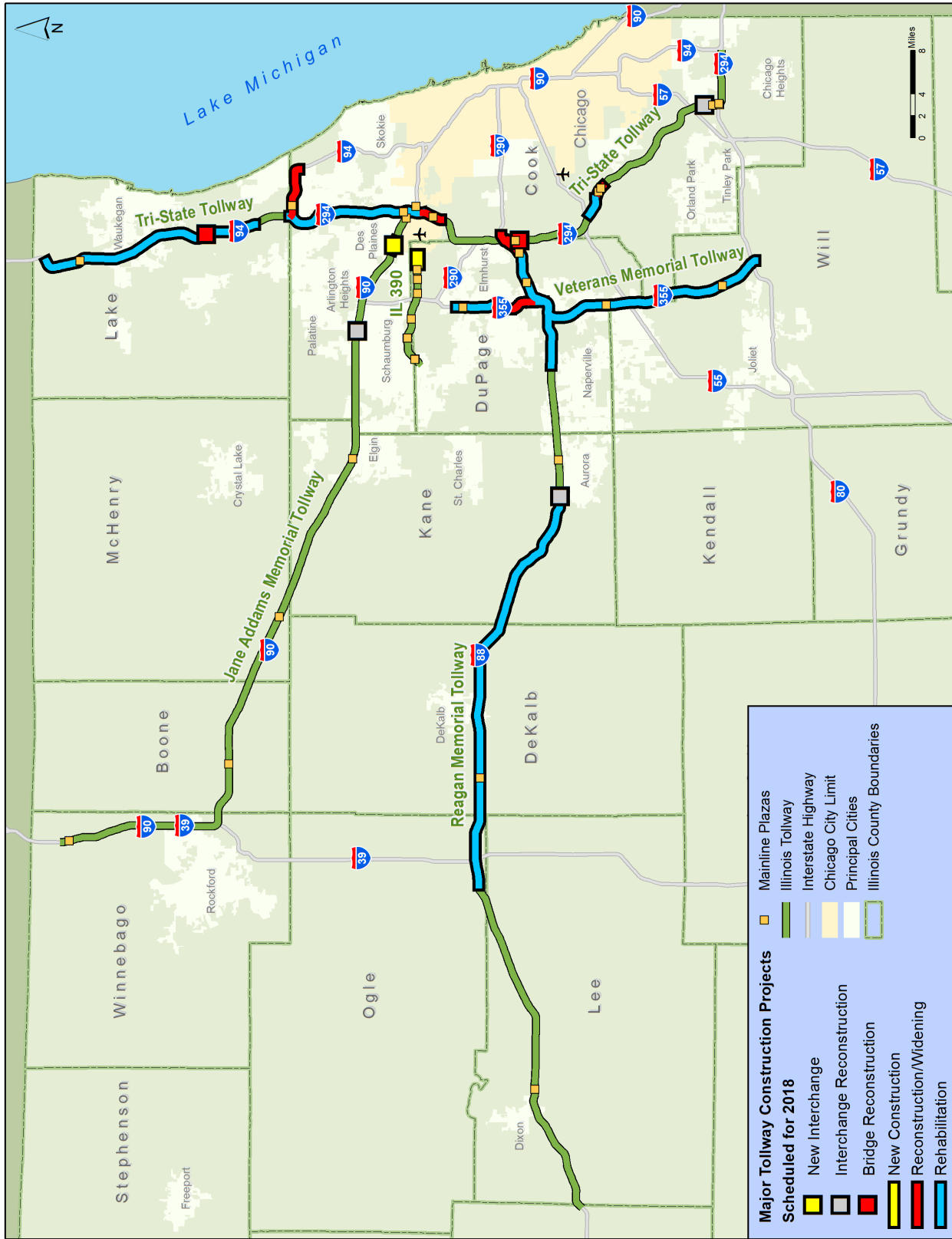

FIGURE 1-F: MAJOR TOLLWAY CONSTRUCTION PROJECTS DURING 2018

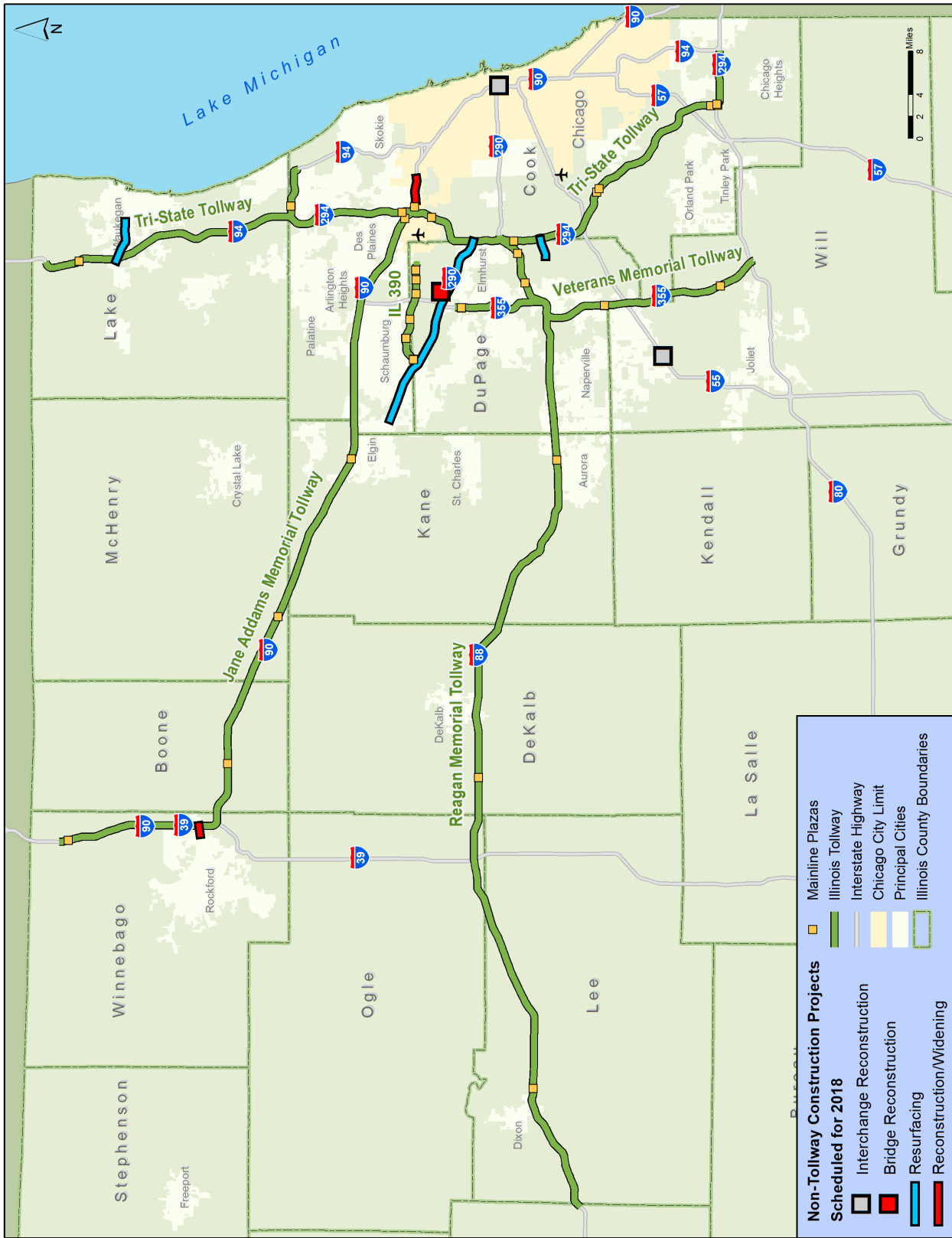
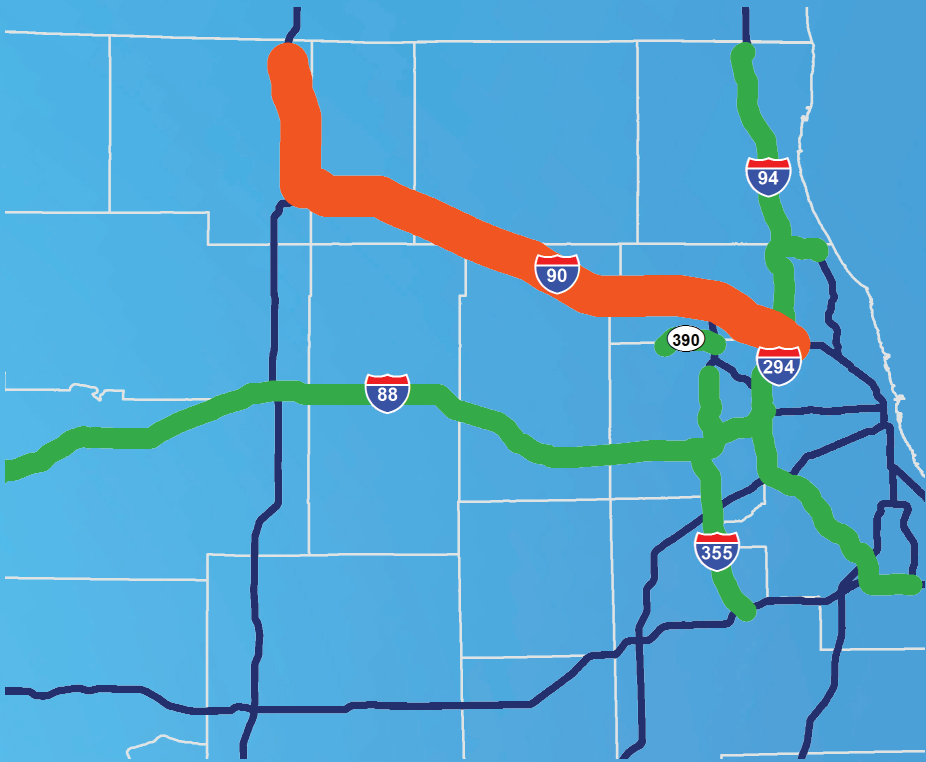

FIGURE 1-G: MAJOR OFF-TOLLWAY CONSTRUCTION PROJECTS DURING 2018

Jane Addams Memorial Tollway

Jane Addams
Memorial Tollway





SECTION 2

Jane Addams Memorial Tollway

TABULATIONS TABLE

	PAGE
2-A Average Daily Traffic Volumes Between Interchanges 1980 – 2018 (Westbound)	2-4
2-B Average Daily Traffic Volumes Between Interchanges 1980 – 2018 (Eastbound)	2-5
2-C General Statistics for Mainline Plazas	2-6
2-D Indexed Monthly Variation by Mainline Plaza	2-8
2-E Indexed Daily Variation by Mainline Plaza	2-8
2-F Annual Total Transactions by Toll Plaza	2-9
2-G Average Daily Traffic Data	2-10

ILLUSTRATIONS FIGURE

	PAGE
2-A Mainline Plaza Highest Hourly Volume Plaza 1 EB	2-11
2-B Mainline Plaza Highest Hourly Volume Plaza 1 WB	2-11
2-C Mainline Plaza Highest Hourly Volume Plaza 5 WB	2-11
2-D Mainline Plaza Highest Hourly Volume Plaza 7 EB	2-11
2-E Mainline Plaza Highest Hourly Volume Plaza 9 EB	2-12
2-F Mainline Plaza Highest Hourly Volume Plaza 9 WB	2-12
2-G Mainline Plaza Highest Hourly Volume Plaza 17 WB	2-12
2-H Mainline Plaza Highest Hourly Volume Plaza 19 EB	2-12
2-I Average Daily Traffic Trends Plaza 1 South Beloit	2-13
2-J Average Daily Traffic Trends Plaza 2 East Riverside Boulevard	2-13
2-K Average Daily Traffic Trends Plaza 3 Genoa Road	2-13
2-L Average Daily Traffic Trends Plaza 4 Illinois Route 173	2-14
2-M Average Daily Traffic Trends Plaza 5 Belvidere	2-14
2-N Average Daily Traffic Trends Plaza 5A Irene Road	2-14
2-O Average Daily Traffic Trends Plaza 6 Illinois Route 47	2-15
2-P Average Daily Traffic Trends Plaza 7 Marengo-Hampshire	2-15
2-Q Average Daily Traffic Trends Plaza 8 Randall Road	2-15
2-R Average Daily Traffic Trends Plaza 9 Elgin	2-16
2-S Average Daily Traffic Trends Plaza 10 Barrington Road	2-16
2-T Average Daily Traffic Trends Plaza 11 Illinois 31	2-16
2-U Average Daily Traffic Trends Plaza 12 Roselle Road	2-17



SECTION 2 Jane Addams Memorial Tollway

ILLUSTRATIONS (CONTINUED) FIGURE

PAGE

2-V	Average Daily Traffic Trends Plaza 12A Meacham Road	2-17
2-W	Average Daily Traffic Trends Plaza 13 Illinois 25	2-17
2-X	Average Daily Traffic Trends Plaza 14 Illinois Route 59	2-18
2-Y	Average Daily Traffic Trends Plaza 15 I-290, Illinois Route 53	2-18
2-Z	Average Daily Traffic Trends Plaza 16 Beverly Road	2-18
2-AA	Average Daily Traffic Trends Plaza 17 Devon Avenue	2-19
2-AB	Average Daily Traffic Trends Plaza 18 Arlington Heights Road	2-19
2-AC	Average Daily Traffic Trends Plaza 18A Elmhurst Road	2-19
2-AD	Average Daily Traffic Trends Plaza 19 River Road	2-20
2-AE	Average Weekday Speed Distributions, Eastern Section—Eastbound	2-21
2-AF	Average Weekday Speed Distributions, Eastern Section—Westbound	2-21
2-AG	Average Weekday Speed Distributions, Western Section—Eastbound	2-21
2-AH	Average Weekday Speed Distributions, Western Section—Westbound	2-21
2-AI	Roadway Performance Measures, Eastern Section	2-22
2-AJ	Roadway Performance Measures, Western Section	2-23
2-AK	Average Speed Contours, MP 55.0 to 78.5	2-24
2-AL	Average Speed Contours, MP 32.0 to 54.5	2-25



This Page Is Intentionally Left Blank

TABLE 2-A: AVERAGE DAILY TRAFFIC VOLUMES BETWEEN INTERCHANGES 1980-2018 (WESTBOUND)

Location	Mile Post	Miles Btwn. Int.	ADT 1980	Average Annual Percent Change	ADT 1990	Average Annual Percent Change	ADT 2000	Average Annual Percent Change	ADT 2010	Average Annual Percent Change	ADT 2018
Kennedy Expressway	78.6										
		0.8	39,270	4.0	58,040	1.4	66,420	-0.5	62,870	-0.54	60,210
Tri-State Interchange	77.8										
		0.5	51,310	3.7	73,590	1.5	85,520	-0.2	83,420	-0.2	82,370
Devon Avenue	77.3										
Toll Plaza 17	77.3	1.2	56,160	3.7	80,790	1.4	93,190	-0.4	89,150	0.1	90,170
Lee Street	76.1										
		1.7	52,730	3.5	74,740	1.6	87,610	-0.5	83,390	0.2	84,440
Des Plaines Oasis	74.4										
		0.9	52,730	3.5	74,740	1.6	87,610	-0.5	83,390	0.2	84,440
Elmhurst Road	73.5										
		2.8	40,790	3.8	59,510	1.8	70,910	-0.1	70,530	1.2	77,460
Arlington Heights Road (PL18)	70.7										
		2.5	34,440	3.8	50,010	3.9	73,120	-0.2	71,440	0.7	75,430
Illinois Route 53/I-290	68.2										
		0.9	29,360	5.9	51,970	3.2	71,530	1.2	80,270	0.3	82,090
Meacham Road (PL12A)	67.3										
		1.8	29,360	5.9	51,970	3.2	71,530	1.2	80,270	0.3	82,210
Roselle Road (PL12)	65.5										
		3.3	29,360	3.9	43,100	3.6	61,490	1.2	69,090	0.9	74,090
Barrington Road (PL10)	62.2										
		2.5	17,070	4.5	26,580	6.4	49,640	1.8	59,410	1.8	68,320
Illinois Route 59 (PL14)	59.7										
		1.6	18,470	4.9	29,780	4.9	48,160	2.4	61,340	1.0	66,480
Beverly Road (PL16)	58.1										
		1.8	18,470	4.9	29,780	3.8	43,120	2.7	56,220	1.0	60,980
Illinois Route 25 (PL13)	56.3										
		1.7	16,330	4.9	26,350	4.7	41,520	2.7	54,370	1.3	60,180
Illinois Route 31 (PL11)	54.6										
Toll Plaza 9	53.8	2.5	11,340	4.2	17,090	6.6	32,270	3.5	45,660	1.4	50,990
Randall Road (PL8)	52.1										
		5.7	11,340	2.9	15,020	5.6	25,780	2.4	32,800	1.3	36,370
Illinois Route 47	46.4										
		4.5	10,130	2.0	12,380	5.4	20,870	1.8	25,040	1.3	27,710
Marenco Road (U.S. Route 20)	41.9										
		16.6	9,340	2.5	12,000	4.9	19,320	1.9	23,390	1.7	26,700
Genoa Road (PL3)	25.3										
		1.1	8,490	2.5	10,860	4.1	16,300	1.8	19,420	2.6	23,900
Belvidere Oasis	24.2										
Toll Plaza 5	23.3	3.4	8,490	2.5	10,860	4.1	16,300	1.8	19,420	2.6	23,900
Irene Road (PL 5A)	20.8										
		3.4	8,490	2.5	10,860	4.1	16,300	1.7	19,200	3.1	24,600
I-39/U.S. Route 20 (Cherry Valley)	17.4										
		2.2	9,160	4.6	14,330	3.9	21,010	3.1	28,380	2.7	35,230
U.S. Business 20	15.2										
		2.9	8,270	5.2	13,750	4.8	22,060	1.7	26,060	2.7	32,160
E. Riverside Boulevard (PL2)	12.3										
		3.4	8,270	4.8	13,180	4.7	20,840	1.5	24,300	2.7	30,060
Illinois Route 173 (PL4)	8.9										
Toll Plaza 1	3.5	6.2	8,270	4.8	13,180	4.7	20,840	0.9	22,800	2.4	27,610
West Terminus	2.7										

TABLE 2-B: AVERAGE DAILY TRAFFIC VOLUMES BETWEEN INTERCHANGES 1980-2018 (EASTBOUND)

Location	Mile Post	Miles Btwn. Int.	ADT 1980	Average Annual Percent Change	ADT 1990	Average Annual Percent Change	ADT 2000	Average Annual Percent Change	ADT 2010	Average Annual Percent Change	ADT 2018
Kennedy Expressway	78.6										
Toll Plaza 19	78.5	0.8	48,260	3.3	67,020	1.3	76,300	-0.9	69,600	-1.6	61,420
Tri-State Interchange	77.8										
		0.5	55,550	3.4	77,830	2.5	99,340	-1.7	83,980	-0.4	81,410
Devon Avenue	77.3										
	77.3	1.2	55,550	3.4	77,830	2.5	99,340	-1.7	83,980	-0.4	81,410
Lee Street	76.1										
		1.7	52,110	3.3	71,920	2.4	91,250	-1.6	77,640	-0.3	75,890
Des Plaines Oasis	74.4										
		0.9	52,110	3.3	71,920	2.4	91,250	-1.6	77,640	-0.3	75,890
Elmhurst Road	73.5										
		2.8	40,200	3.6	57,210	2.3	72,090	-0.5	68,390	0.6	71,660
Arlington Heights Road (PL18)	70.7										
		2.5	33,800	3.6	48,150	4.3	73,360	-0.4	70,680	0.0	70,480
Illinois Route 53/I-290 (PL 15)	68.2										
		2.7	29,110	5.8	50,930	4.2	77,040	0.7	82,430	-0.4	79,930
Roselle Road	65.5										
		3.3	29,110	3.9	42,540	4.8	68,280	0.4	70,850	0.8	75,380
Barrington Road	62.2										
		2.5	16,770	4.6	26,250	7.5	54,030	0.9	59,150	1.9	68,980
Illinois Route 59 (PL14)	59.7										
		1.6	18,090	5.0	29,480	5.5	50,150	1.9	60,830	1.0	65,910
Beverly Road	58.1										
		1.8	18,090	5.0	29,480	4.3	44,840	2.1	55,370	1.1	60,350
Illinois Route 25 (PL13)	56.3										
		1.7	15,860	5.1	26,180	5.1	43,030	2.3	54,220	1.3	59,950
Illinois Route 31 (PL11)	54.6										
Toll Plaza 9	53.8	2.5	11,660	4.1	17,360	6.6	32,790	3.3	45,350	1.5	50,970
Randall Road (PL8)	52.1										
		5.7	11,660	2.7	15,290	5.5	26,180	2.5	33,500	1.3	37,040
Illinois Route 47	46.4										
		4.5	10,360	2.0	12,620	5.1	20,770	2.5	26,520	0.9	28,530
Marengo Road (U.S. Route 20)	41.9										
Toll Plaza 7		16.6	9,290	2.6	12,000	4.7	19,010	2.0	23,220	1.7	26,490
Genoa Road (PL3)	25.3										
		1.1	8,720	2.3	10,990	4.1	16,430	2.2	20,470	2.1	24,090
Belvidere Oasis	24.2										
		3.4	8,720	2.3	10,990	4.1	16,430	2.2	20,470	2.1	24,090
Irene Road (PL 5A)	20.8										
		3.4	8,720	2.3	10,990	4.1	16,430	2.2	20,470	2.4	24,810
I-39/U.S. Route 20 (Cherry Valley)	17.4										
		2.2	9,490	4.6	14,920	3.5	20,960	2.9	27,820	2.9	35,050
U.S. Business 20	15.2										
		2.9	8,430	5.2	14,000	4.3	21,370	2.2	26,690	2.6	32,740
E. Riverside Boulevard (PL2)	12.3										
		3.4	8,430	4.8	13,450	4.1	20,100	2.1	24,680	2.7	30,480
Illinois Route 173 (PL4)	8.9										
Toll Plaza 1	3.5	6.2	8,430	4.8	13,450	4.1	20,100	1.5	23,420	2.3	28,120
West Terminus	2.7										



**TABLE 2-C: GENERAL STATISTICS FOR MAINLINE PLAZAS
(Vehicles/Hour)**

Mainline Plaza	Dir.	30th HV	Period	Mean	Med.	Max.	Min.	Std. Dev.	85th %
1 South Beloit	EB	3,226	AM Peak	1,437	1,356	1,890	832	266	1,743
			PM Peak	1,999	1,981	2,682	1,378	235	2,248
			OFF Peak	1,031	952	2,684	109	619	1,718
			Weekend	1,203	1,116	3,451	88	810	2,138
			Holidays	1,207	1,032	3,611	47	905	2,365
	WB	3,049	AM Peak	1,316	1,313	1,831	572	220	1,559
			PM Peak	1,955	1,935	2,722	1,136	233	2,197
			OFF Peak	1,017	1,005	2,830	110	588	1,665
			Weekend	1,190	1,138	3,268	90	777	2,091
			Holidays	1,155	1,028	3,944	65	856	2,033
5 Belvidere	WB	2,643	AM Peak	1,159	1,139	1,596	378	209	1,409
			PM Peak	1,547	1,532	2,188	863	198	1,742
			OFF Peak	862	861	2,218	101	493	1,417
			Weekend	1,061	1,049	2,921	87	658	1,802
			Holidays	1,037	958	3,493	72	746	1,734
7 Marengo-Hampshire	EB	3,102	AM Peak	1,585	1,616	1,816	750	157	1,696
			PM Peak	1,537	1,538	2,176	911	194	1,755
			OFF Peak	946	1,047	2,287	86	522	1,497
			Weekend	1,170	1,173	3,426	86	753	1,989
			Holidays	1,168	1,094	3,717	90	816	1,997
9 Elgin	EB	5,360	AM Peak	4,820	4,897	5,605	2,052	471	5,225
			PM Peak	2,840	2,878	3,617	2,062	276	3,109
			OFF Peak	1,842	1,903	4,606	150	1,157	3,043
			Weekend	2,068	2,133	5,099	177	1,265	3,441
			Holidays	2,004	2,028	4,672	208	1,248	3,407
	WB	5,632	AM Peak	2,286	2,265	2,858	804	352	2,691
			PM Peak	4,915	4,959	5,687	3,143	410	5,277
			OFF Peak	1,895	2,002	5,833	106	1,203	3,057
			Weekend	2,067	2,105	5,933	171	1,273	3,345
			Holidays	1,969	1,866	6,178	137	1,349	3,231

(cont'd)

**TABLE 2-C: GENERAL STATISTICS FOR MAINLINE PLAZAS
(Vehicles/Hour)**

Mainline Plaza	Dir.	30th HV	Period	Mean	Med.	Max.	Min.	Std. Dev.	85th %
17 Devon Avenue	WB	7,986	AM Peak	5,613	5,350	6,939	2,849	765	6,479
			PM Peak	7,448	7,479	8,397	4,875	461	7,842
			OFF Peak	3,483	3,869	7,314	280	1,967	5,776
			Weekend	3,501	3,681	7,944	385	1,816	5,273
			Holidays	3,148	3,194	7,714	390	1,791	5,046
19 River Road	EB	4,774	AM Peak	3,319	3,133	4,581	2,168	564	3,983
			PM Peak	3,309	3,289	4,633	2,207	411	3,765
			OFF Peak	2,429	2,860	5,422	176	1,340	3,780
			Weekend	2,549	3,052	5,104	121	1,280	3,781
			Holidays	2,412	2,837	5,168	223	1,315	3,714

AM Peak = Weekday 6:00 AM To 8:00 AM Except Fridays
 PM Peak = Weekday 4:00 PM To 6:00 PM Except Fridays
 OFF Peak = Weekdays Except Fridays and AM and PM Peak Periods
 Weekend = Fridays, Saturdays, and Sundays
 Holidays = See Page 1-6 for a list of Holidays.



TABLE 2-D: INDEXED MONTHLY VARIATION BY MAINLINE PLAZA

Month	South Beloit	Belvidere	Marengo	Elgin	Devon Avenue	River Road
January	0.78	0.75	0.77	0.82	0.90	0.92
February	0.83	0.79	0.81	0.85	0.93	0.94
March	0.94	0.90	0.91	0.93	1.01	1.02
April	0.94	0.94	0.95	0.96	1.00	1.01
May	1.05	1.06	1.05	1.04	1.04	1.01
June	1.15	1.16	1.13	1.09	1.09	1.03
July	1.21	1.19	1.19	1.10	1.04	1.02
August	1.19	1.22	1.18	1.12	1.06	1.04
September	1.04	1.06	1.07	1.05	1.00	1.01
October	1.01	1.04	1.04	1.06	1.01	1.02
November	0.95	0.98	0.98	1.00	0.96	0.95
December	0.89	0.92	0.92	0.97	0.96	1.04

TABLE 2-E: INDEXED DAILY VARIATION BY MAINLINE PLAZA

Month	Day	South Beloit	Belvidere	Marengo	Elgin	Devon Avenue	River Road
August	Monday	1.16	1.18	1.15	1.10	1.06	1.06
	Tuesday	1.11	1.13	1.12	1.06	1.02	1.02
	Wednesday	1.14	1.16	1.14	1.08	1.04	1.05
	Thursday	1.16	1.19	1.14	1.09	1.03	1.04
	Friday	1.19	1.28	1.14	1.11	1.03	1.03
	Saturday	1.23	1.25	1.24	1.16	1.08	1.04
	Sunday	1.30	1.24	1.35	1.20	1.09	1.03
December	Monday	0.83	0.89	0.87	0.95	0.94	1.03
	Tuesday	0.89	0.94	0.96	0.98	0.92	1.04
	Wednesday	1.00	1.01	1.01	1.02	0.98	1.06
	Thursday	0.93	0.94	0.96	0.99	0.98	1.05
	Friday	0.90	0.88	0.97	0.99	1.00	1.08
	Saturday	0.94	0.93	0.94	0.99	0.99	1.03
	Sunday	0.80	0.87	0.77	0.90	0.95	1.00

Table 2-E includes Monthly Variation

TABLE 2-F: ANNUAL TOTAL TRANSACTIONS BY TOLL PLAZA

Plaza	Plaza Code*	2017	2018	Percentage Change
1 South Beloit	M	20,084,428	20,338,911	1.3%
2 E. Riverside Boulevard	R	3,209,982	3,191,117	-0.6%
3 Genoa Road	R	1,688,930	1,768,753	4.7%
4 Illinois Route 173	R	2,254,672	2,271,760	0.8%
5 Belvidere	M1	8,050,685	8,724,636	8.4%
5A Irene Road	R	507,601	634,097	24.9%
6 Illinois Route 47	E	7,650,300	8,503,922	11.2%
7 Marengo	M1	8,990,735	9,661,533	7.5%
8 Randall Road	R	2,686,752	2,734,160	1.8%
9 Elgin	M	34,695,414	37,213,856	7.3%
10 Barrington Road	R	5,582,410	9,997,457	79.1%
11 Illinois Route 25	R	7,246,917	7,992,154	10.3%
12 Roselle Road	R	8,878,216	9,208,116	3.7%
12A Meacham Road	E	2,095,082	2,802,446	33.8%
13 Illinois Route 25	R	2,288,317	2,583,350	12.9%
14 Illinois Route 59	R	2,648,830	2,256,307	-14.8%
15 Illinois Route 53	R1	12,082,314	11,502,455	-4.8%
16 Beverly Road	R1	4,882,470	5,066,080	3.8%
17 Devon Avenue	M1	32,461,255	32,913,535	1.4%
18 Arlington Heights Road	R	7,024,281	6,136,052	-12.6%
18A Elmhurst Road**	E	1,795,874	4,979,208	177.3%
19 River Road	M1	22,432,431	22,418,936	-0.1%
Jane Addams Memorial Total		199,237,896	212,898,841	6.9%

* M=Mainline / R=Ramp / A=Attended Ramp Plaza / E=Electronic Toll Collection Only Ramp
1= Toll Collected in One Direction Only

** New tolled ramps opened at Plaza 18A in 2017.



TABLE 2-G: AVERAGE DAILY TRAFFIC DATA

Year	Average Daily Total			Average Trip
	Vehicles	Vehicle Miles	Transactions	Length (Miles)
1959	10,937	513,839	16,852	46.98
1960	21,417	720,403	29,637	33.64
1961	30,379	893,740	41,601	29.42
1962	35,337	978,261	48,297	27.68
1963	36,384	1,060,625	52,810	29.15
1964	38,704	1,130,304	55,528	29.20
1965	44,034	1,239,411	62,735	28.15
1966	49,418	1,348,751	68,336	27.29
1967	53,402	1,397,288	73,035	26.17
1968	59,443	1,535,620	81,811	25.83
1969	66,752	1,637,427	118,986	24.53
1970	75,218	1,757,108	138,024	23.36
1971	81,517	1,867,136	146,198	22.90
1972	87,416	1,929,076	156,403	22.07
1973	102,262	2,070,220	175,930	20.24
1974	101,814	2,001,520	171,108	19.66
1975	110,185	2,141,250	184,352	19.43
1976	118,923	2,301,465	199,710	19.35
1977	126,388	2,435,431	212,020	19.27
1978	134,830	2,502,453	220,878	18.56
1979	139,786	2,606,029	228,180	18.64
1980	140,928	2,536,515	227,729	18.00
1981	143,284	2,619,176	230,868	18.28
1982	146,090	2,634,806	234,034	18.04
1983	152,561	2,770,933	247,674	18.16
1984	144,728	2,666,506	238,152	18.42
1985	164,771	2,861,454	257,366	17.37
1986	175,655	3,134,635	281,112	17.85
1987	191,936	3,392,046	307,469	17.67
1988	205,510	3,558,352	329,391	17.31
1989	213,965	3,643,665	336,575	17.03
1990	225,655	3,669,541	347,884	16.26
1991	222,370	3,673,993	365,120	16.52
1992	234,074	4,081,095	375,921	17.44
1993	253,304	4,279,655	389,127	16.90
1994	260,359	4,533,228	412,288	17.41
1995	269,680	4,774,725	432,373	17.71
1996	275,020	4,912,102	439,095	17.86
1997	282,900	5,105,618	454,622	18.05
1998	284,860	5,125,064	480,098	17.99
1999	294,050	5,567,182	512,810	18.93
2000	294,850	5,402,466	507,784	18.32
2001	309,100	5,828,988	541,479	18.86
2002	296,870	5,773,234	532,658	19.45
2003	304,510	5,857,387	541,345	19.24
2004	323,450	6,158,090	556,501	19.04
2005	312,300	6,002,609	530,257	19.22
2006	312,990	5,918,699	478,556	18.91
2007	318,420	6,120,967	492,225	19.22
2008	313,550	5,853,800	479,141	18.67
2009	308,050	5,744,595	473,015	18.65
2010	335,170	5,994,090	484,642	17.88
2011	317,070	5,813,945	470,237	18.34
2012	308,770	5,659,154	456,180	18.33
2013	309,780	5,376,980	448,008	17.36
2014	307,320	5,327,905	455,312	17.34
2015	314,120	5,598,660	467,606	17.82
2016	310,850	5,635,519	468,331	18.13
2017	349,460	6,294,069	545,857	18.01
2018	356,220	6,580,377	583,284	18.47



FIGURE 2-B

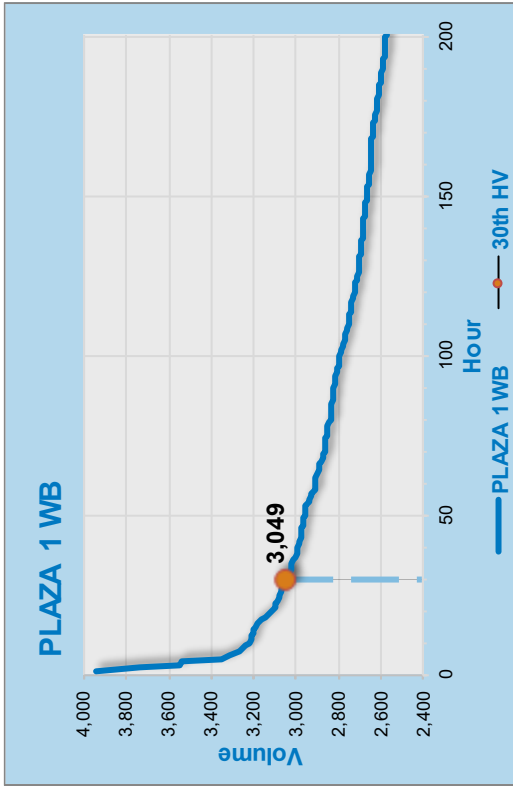

FIGURE 2-D

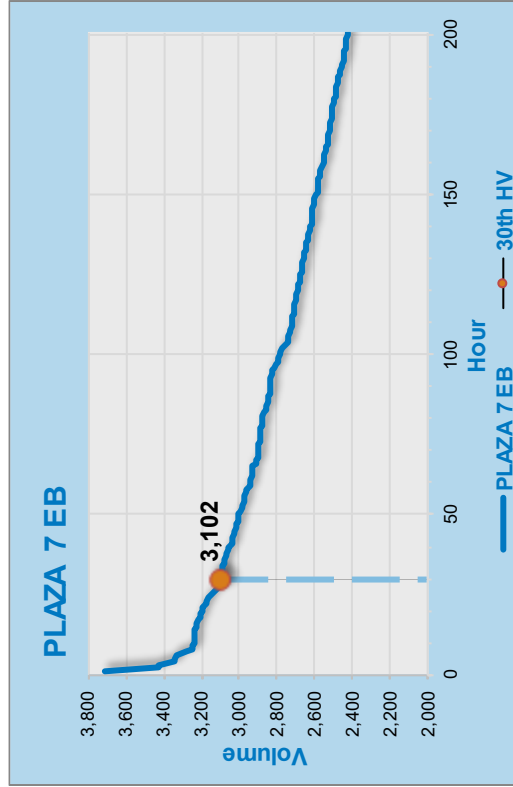

FIGURE 2-A

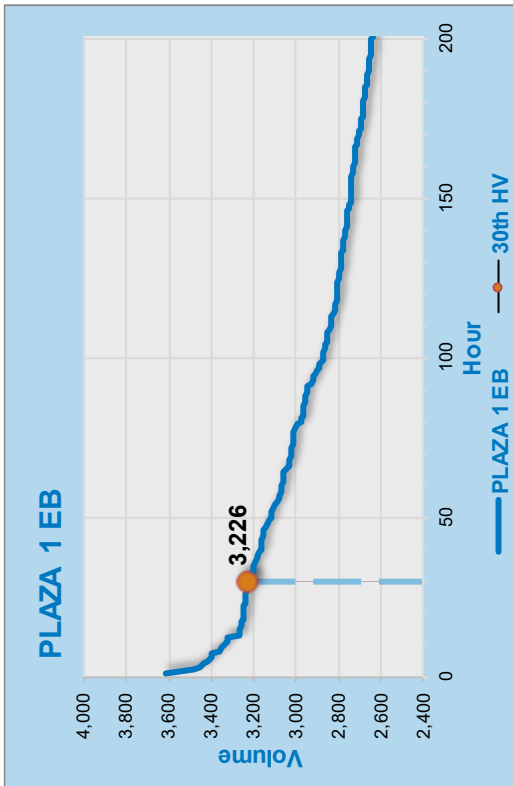
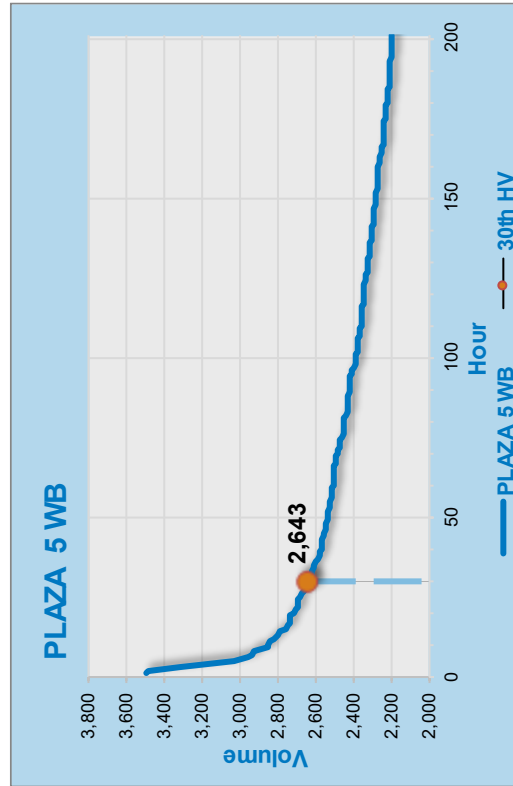

FIGURE 2-C



MAINLINE PLAZA HIGHEST HOURLY VOLUME



FIGURE 2-F

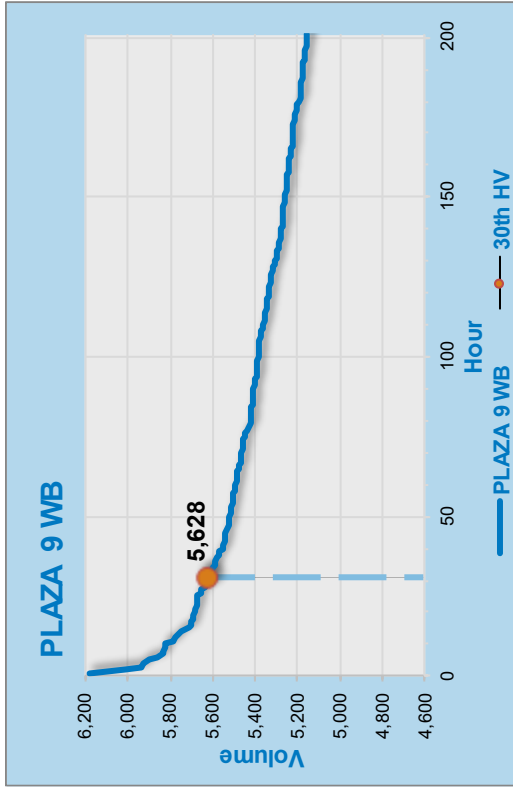

FIGURE 2-H

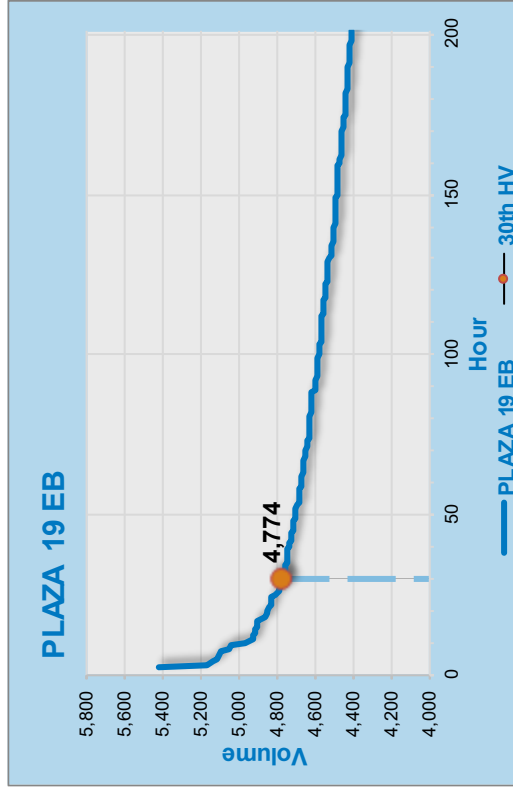

FIGURE 2-E

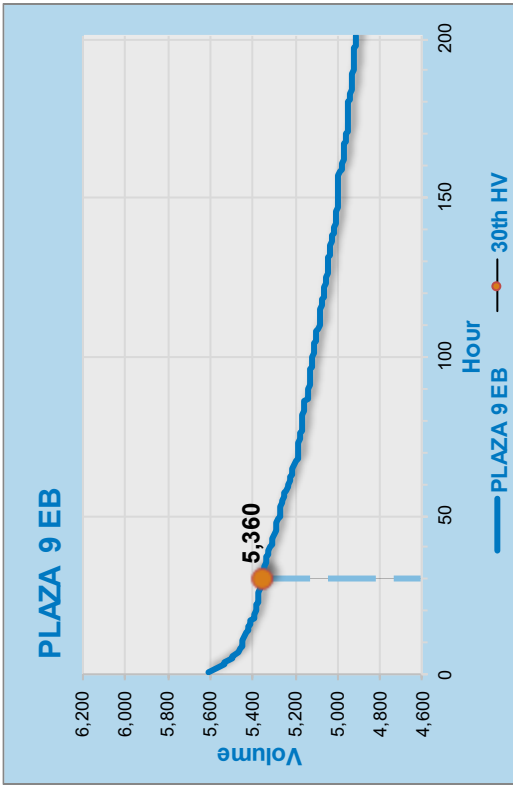
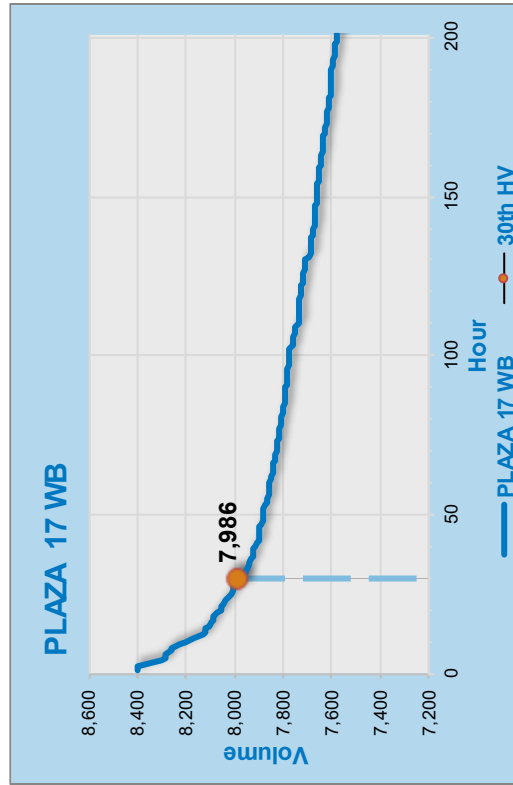

FIGURE 2-G



MAINLINE PLAZA HIGHEST HOURLY VOLUME

FIGURE 2-I

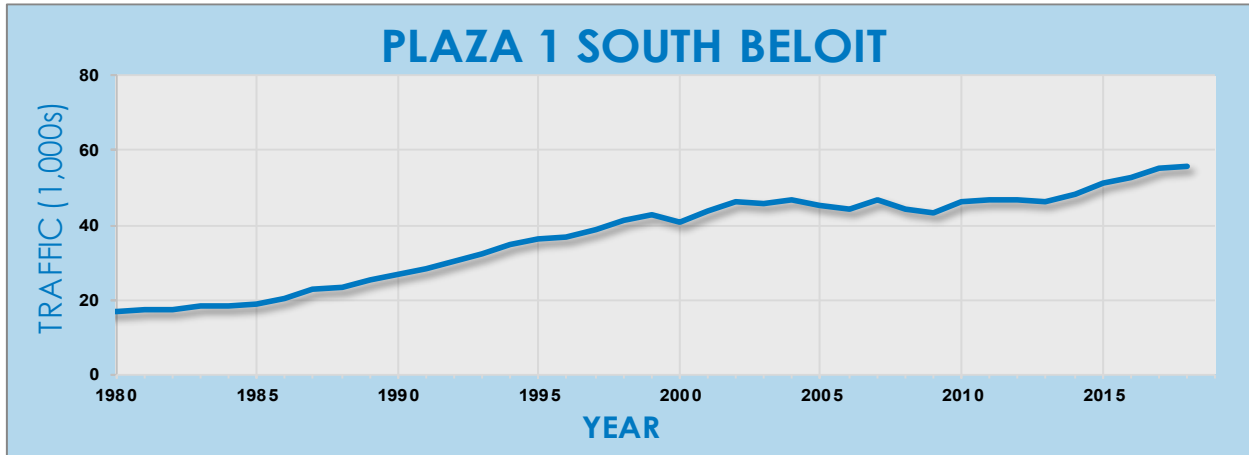

FIGURE 2-J

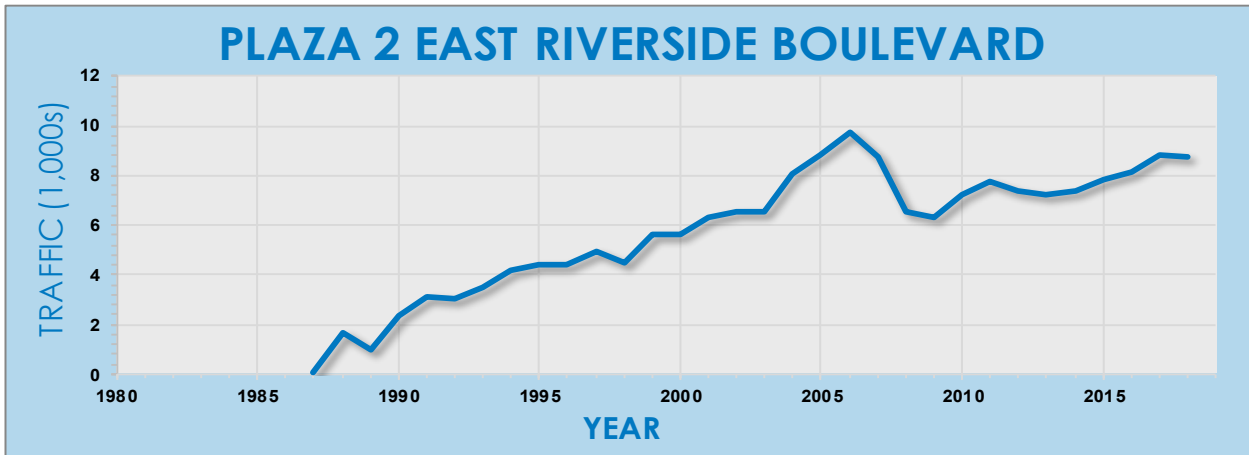
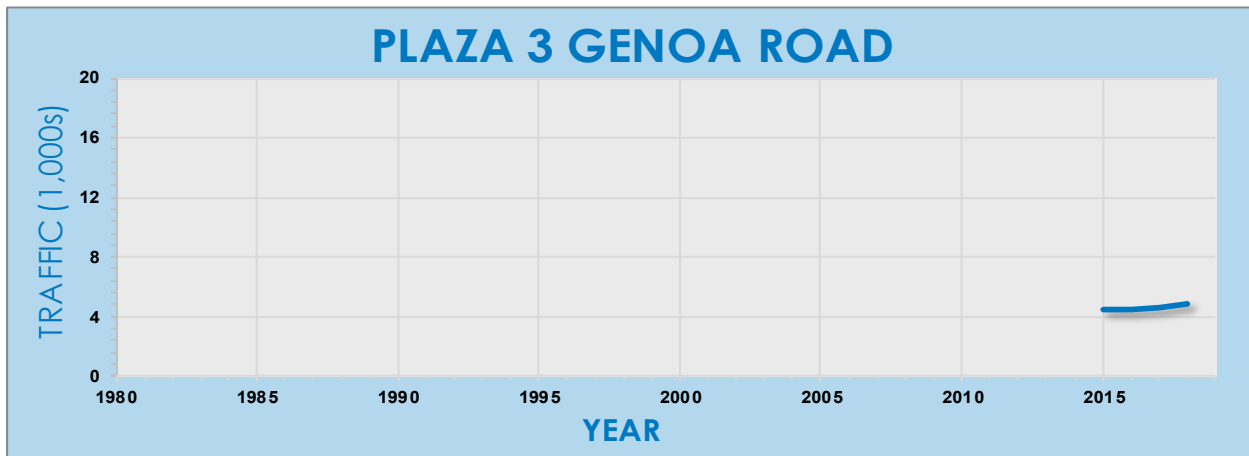

FIGURE 2-K

Genoa Road opened September 2015.



AVERAGE DAILY TRAFFIC TRENDS



FIGURE 2-L

Plaza 4 opened in 2007.

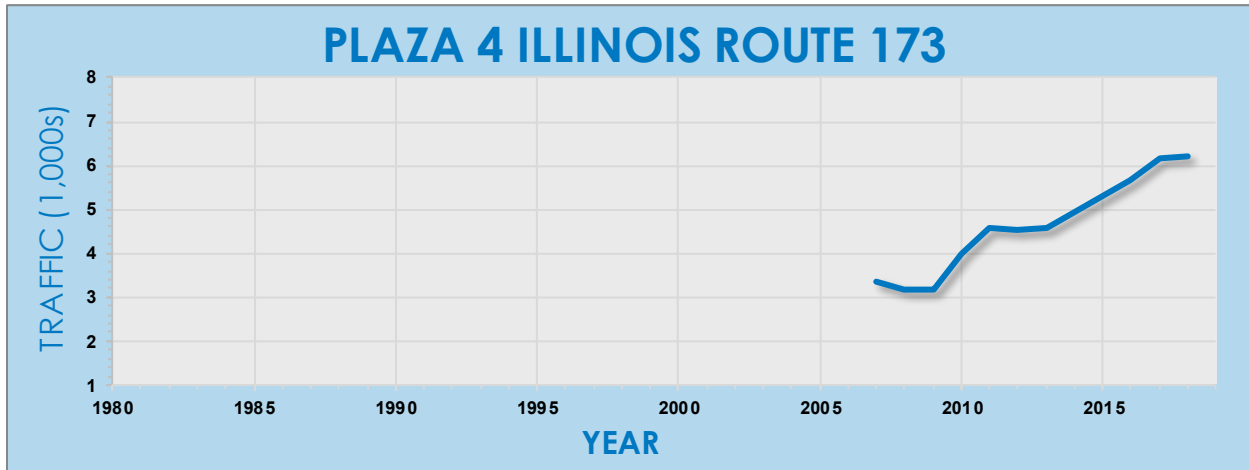

FIGURE 2-M

Plaza 5 converted to one way tolling (WB) in 2006.

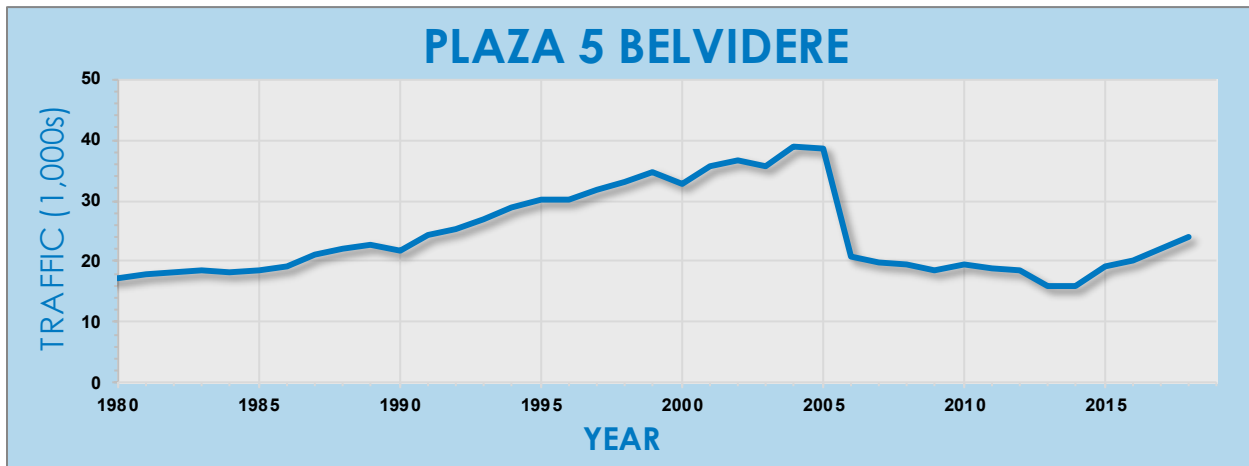
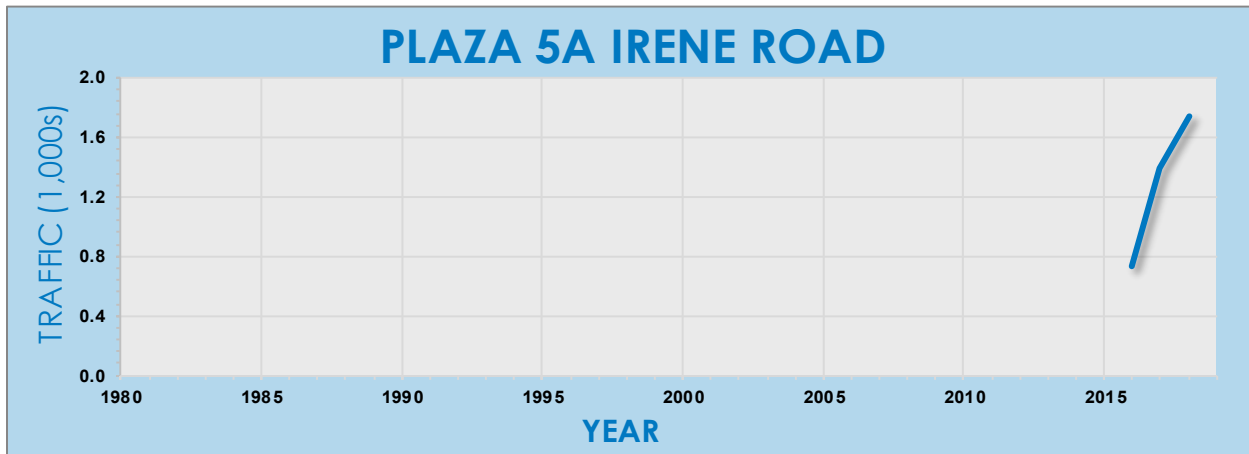

FIGURE 2-N

Plaza 5A opened in January 2016.



AVERAGE DAILY TRAFFIC TRENDS

FIGURE 2-O

Plaza 6 opened in 2013.

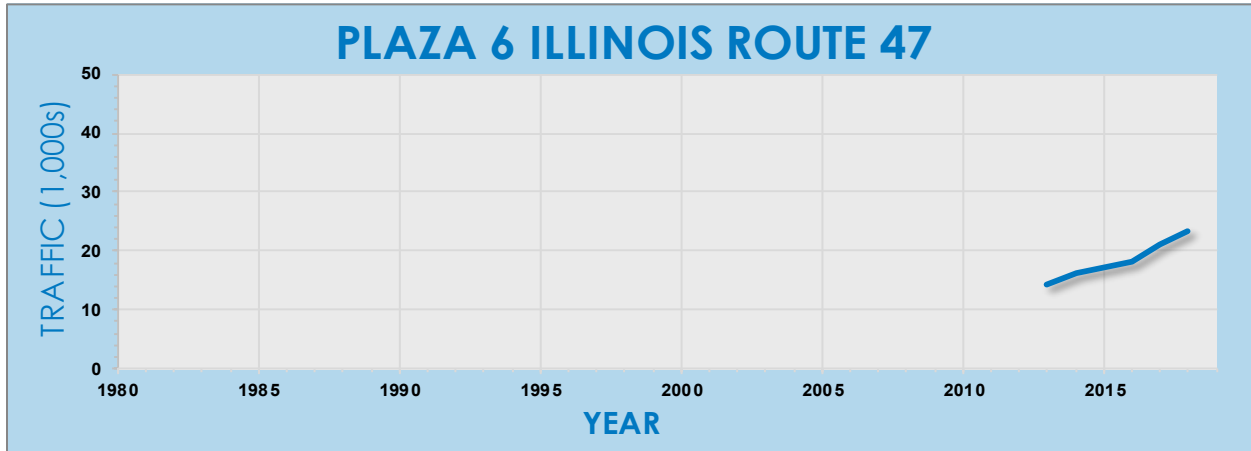

FIGURE 2-P

Plaza 7 converted to one way tolling (EB) in 2006.

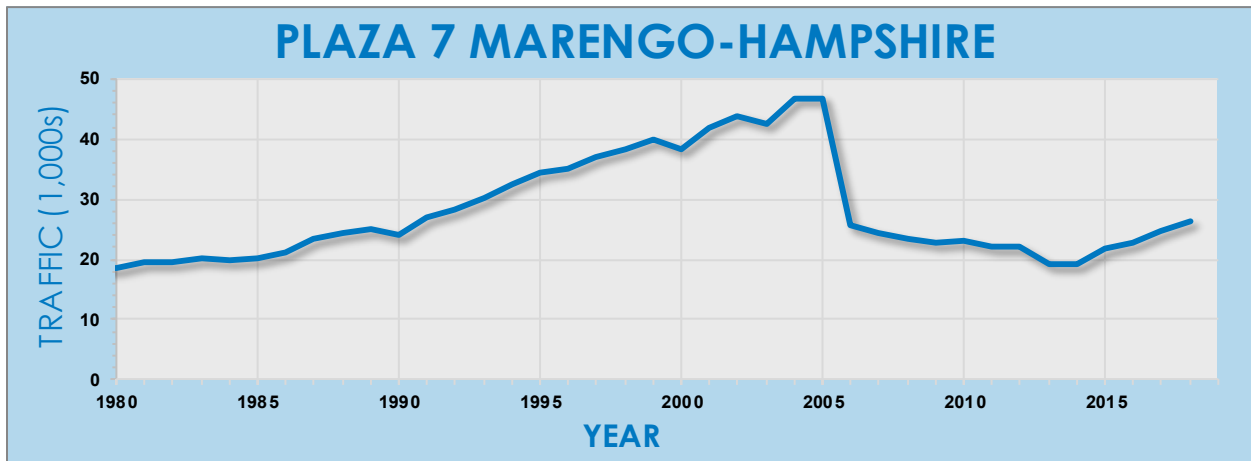
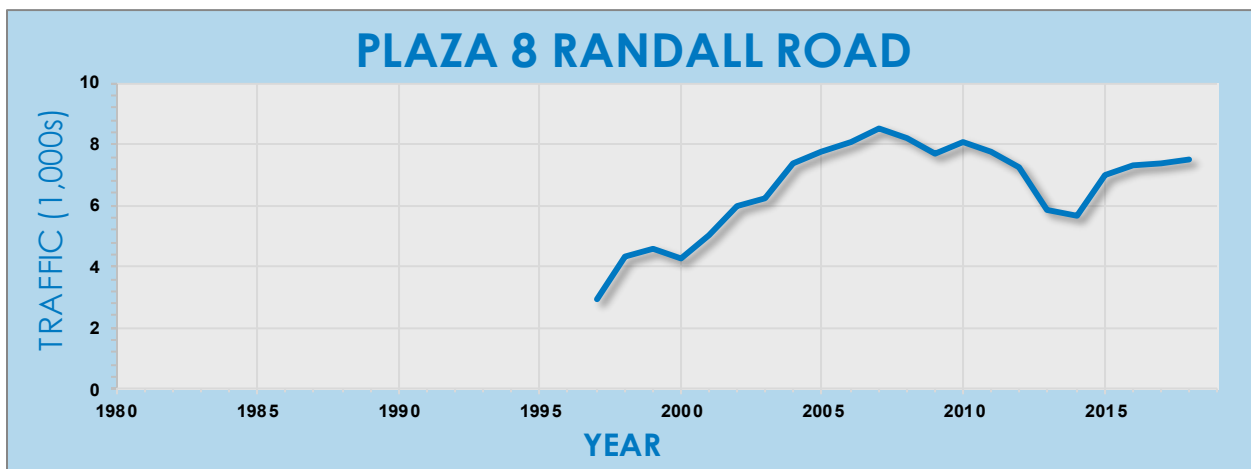

FIGURE 2-Q

Ramps to and from the west opened in 1997.



AVERAGE DAILY TRAFFIC TRENDS

FIGURE 2-R

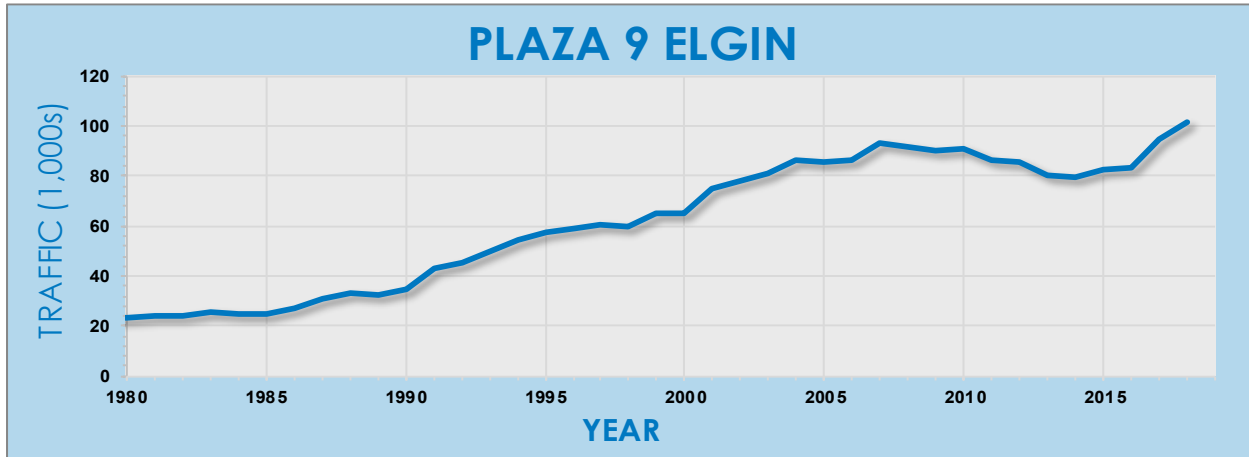

FIGURE 2-S

Additional tolled movements opened at Plaza 10 in 2018.

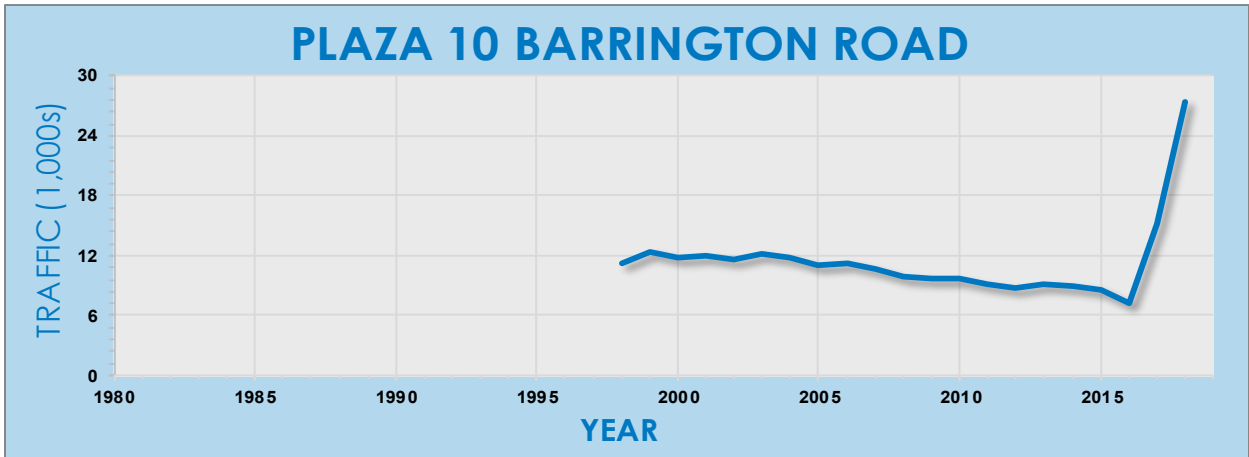
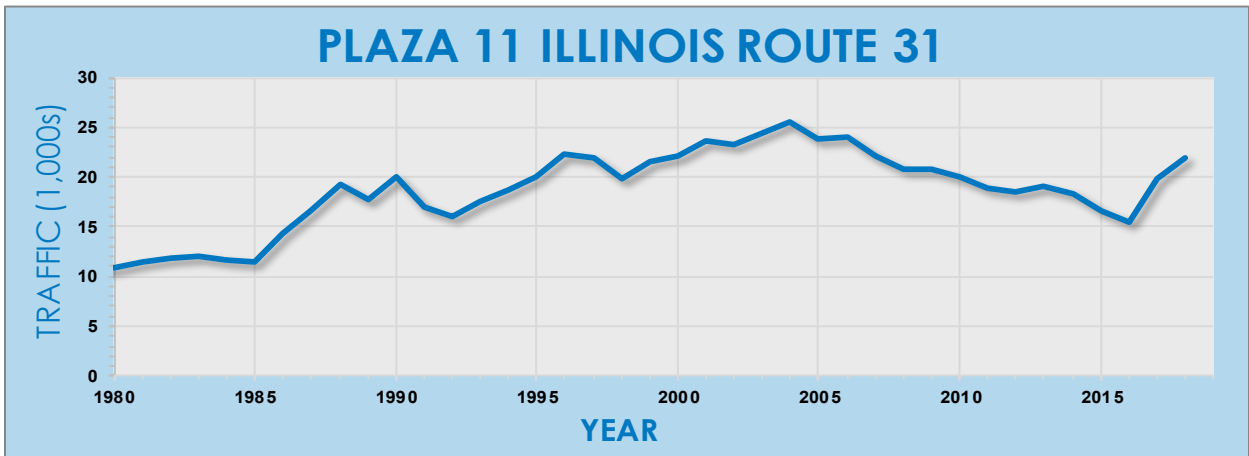

FIGURE 2-T



AVERAGE DAILY TRAFFIC TRENDS

FIGURE 2-U

Plaza 12 opened in 1998 due to Plaza 15 reconfiguration. Additional tolled movements opened in 2016.

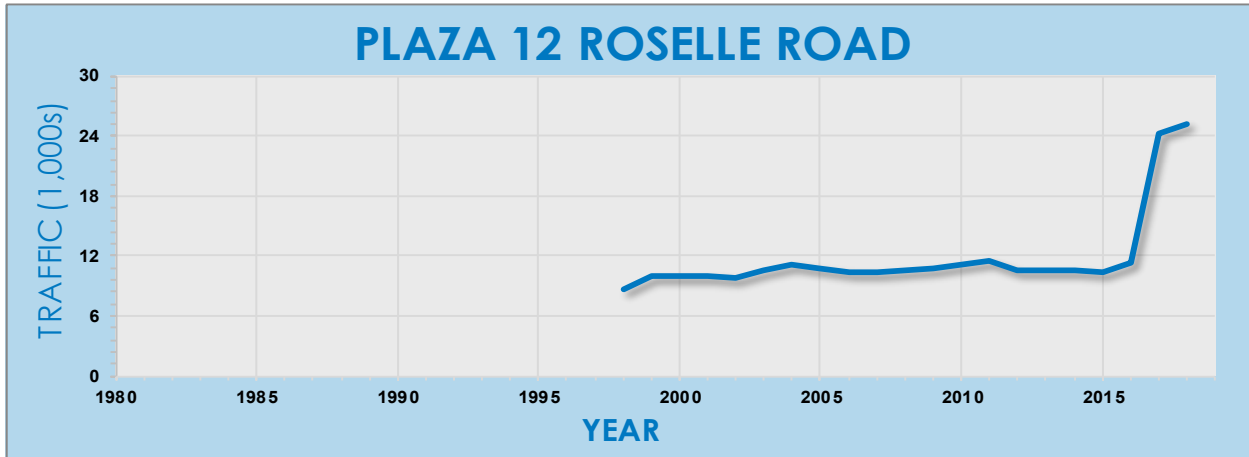

FIGURE 2-V

Plaza 12A opened in 2016.

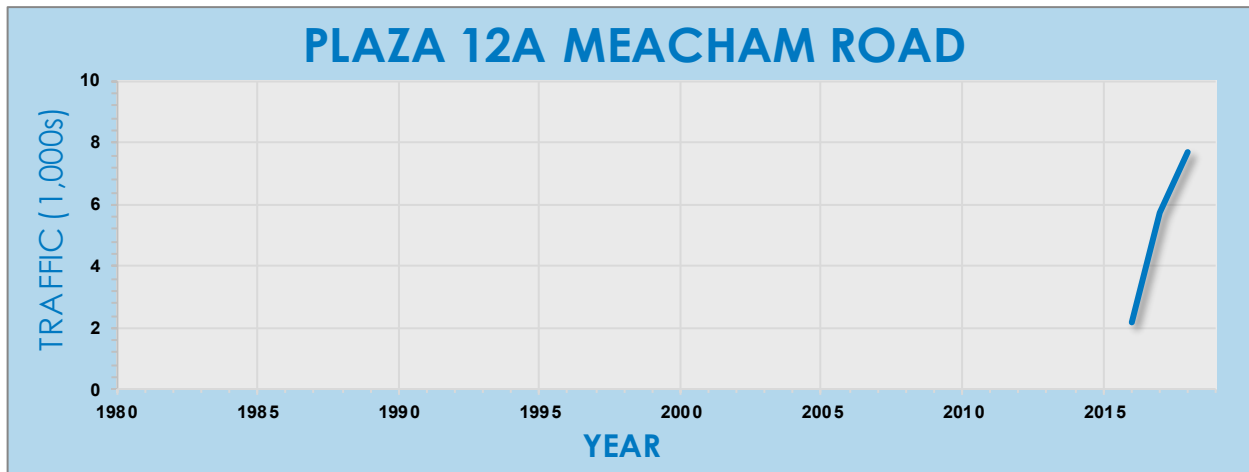
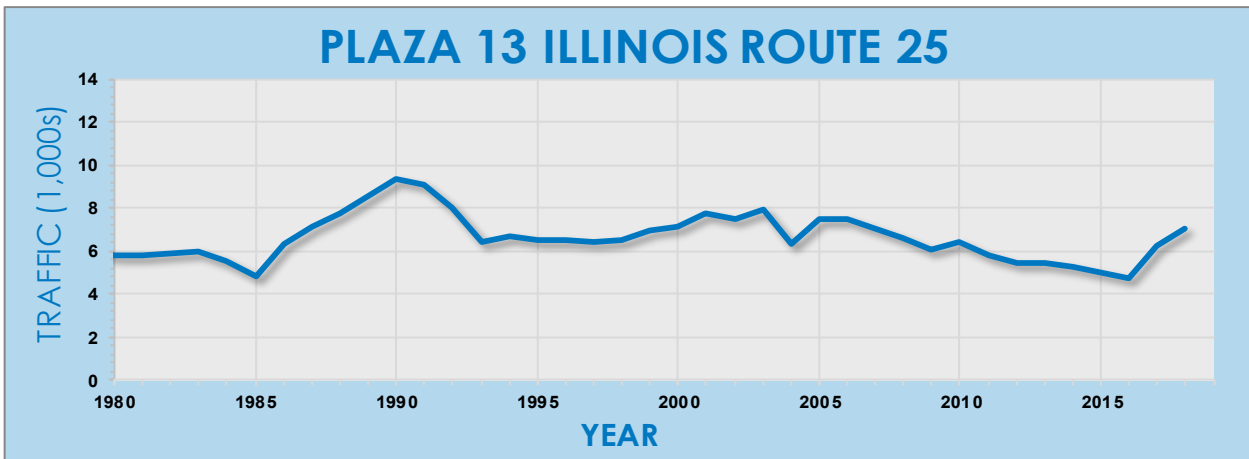

FIGURE 2-W



AVERAGE DAILY TRAFFIC TRENDS

FIGURE 2-X

Note: The Plaza 14 graph shows transactions at the EB I-90 to Illinois Route 59 collection point only. Transactions for the WB I-90 to Illinois Route 59 collection point are included with the Plaza 16 graph. Plazas opened in 1998 due to Plaza 15 reconfiguration.

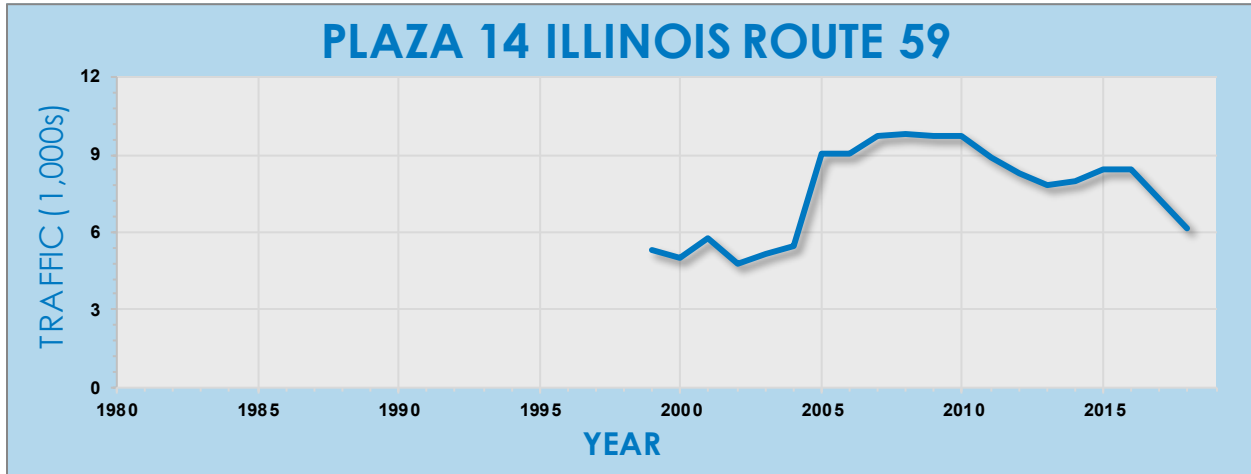

FIGURE 2-Y

Westbound tolls removed in 1997.

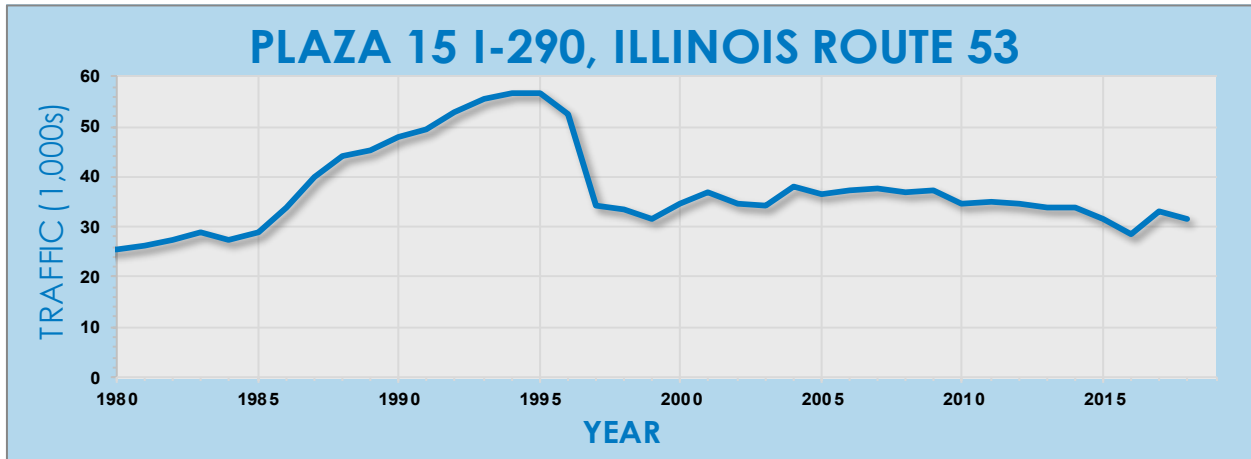
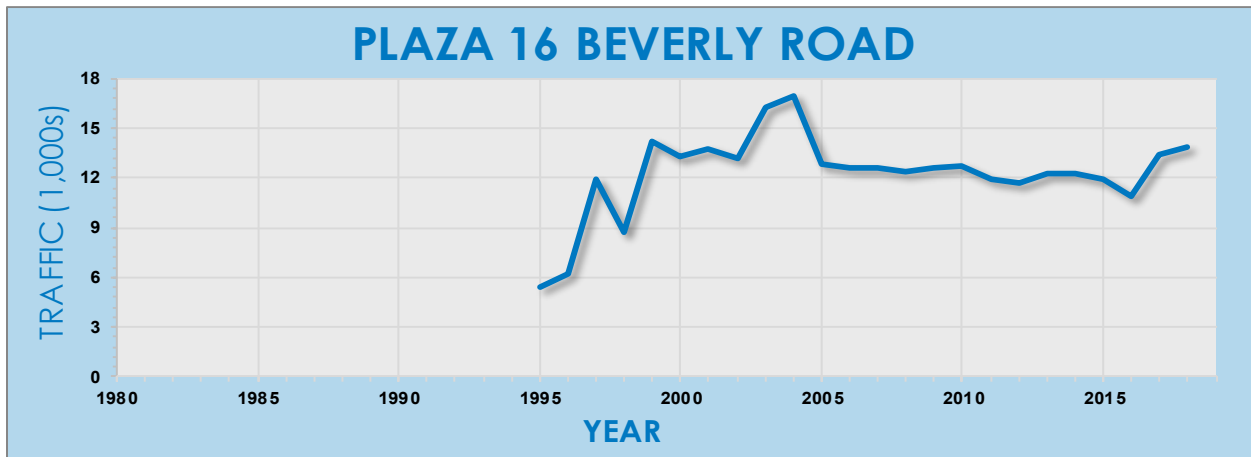

FIGURE 2-Z

Note: The Plaza 16 graph shows transactions from two collection points: (1) WB I-90 to Illinois Route 59 (Plaza 16a) and (2) WB I-90 to Beverly Road (Plaza 16b). Plaza 16b opened in 1995.



AVERAGE DAILY TRAFFIC TRENDS

FIGURE 2-AA

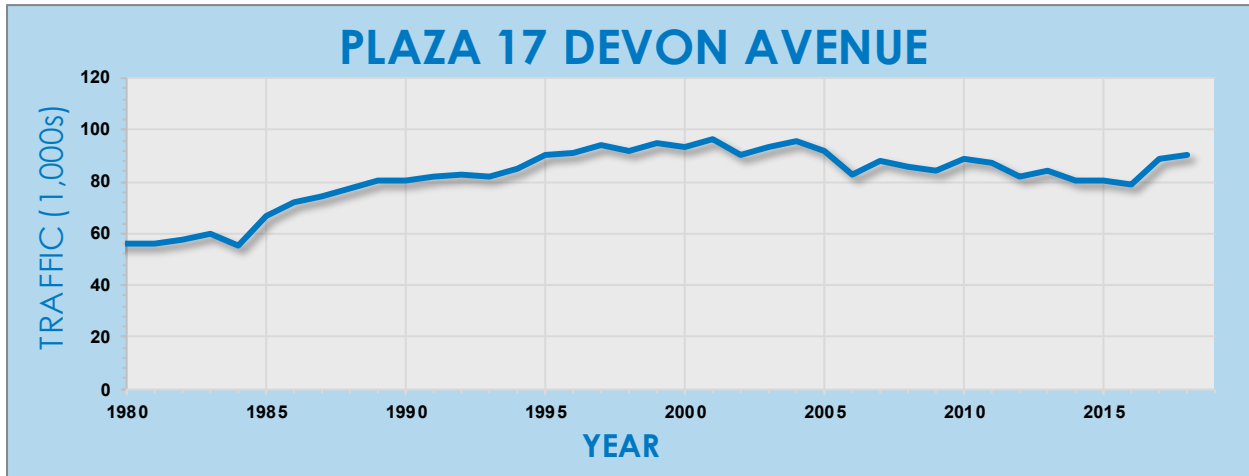

FIGURE 2-AB

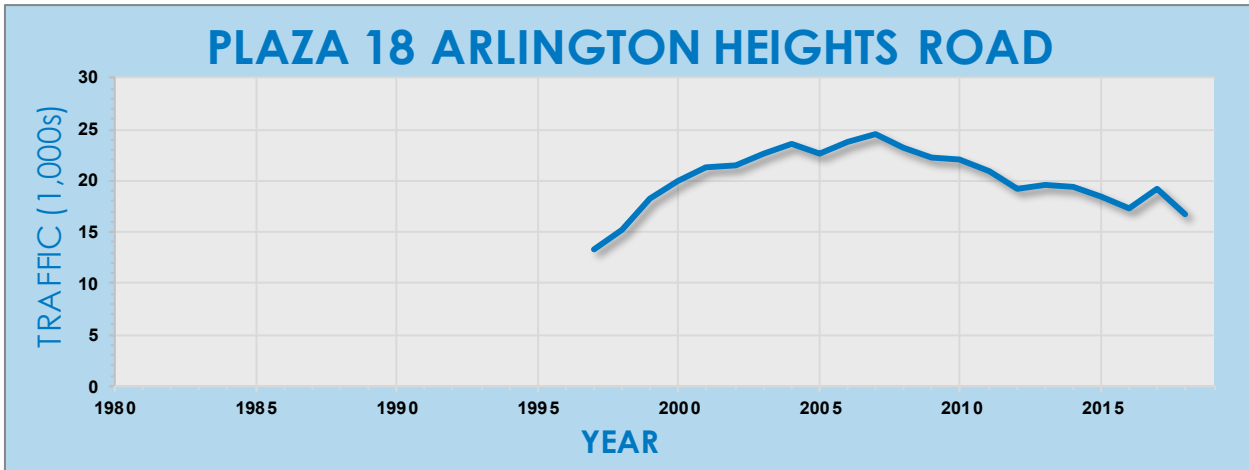
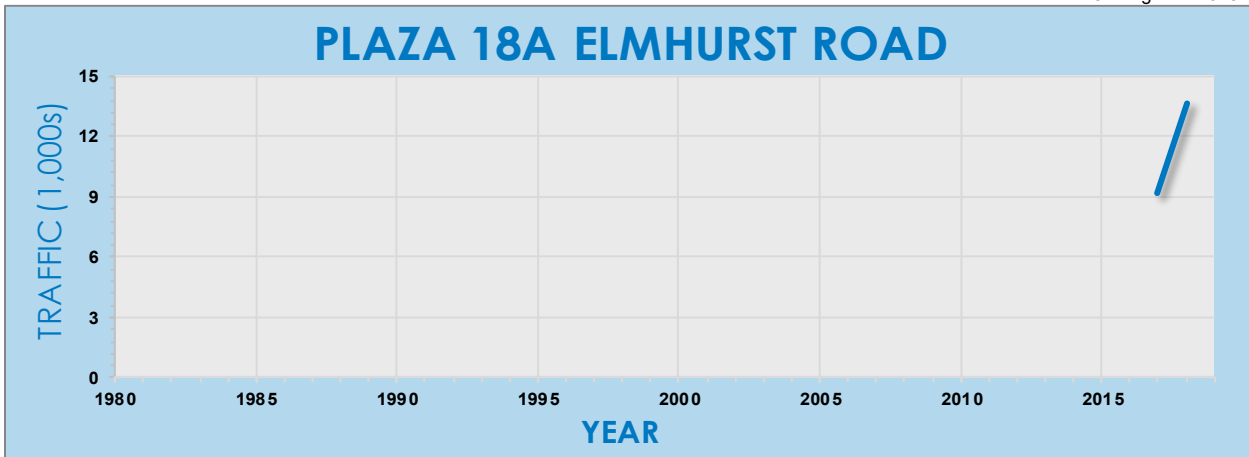

FIGURE 2-AC

Toll collection at Plaza 18A began in 2018.



AVERAGE DAILY TRAFFIC TRENDS



FIGURE 2-AD

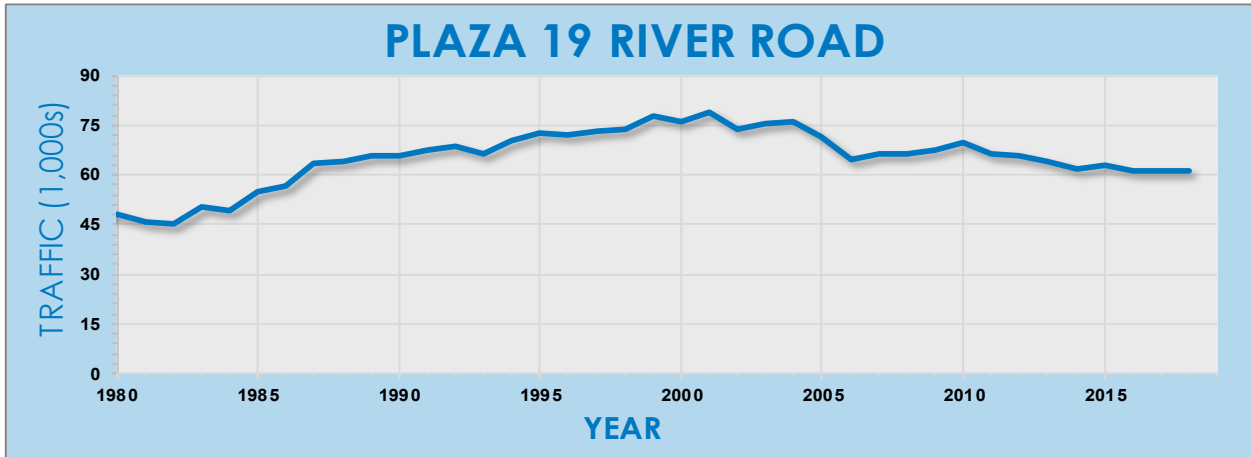

AVERAGE DAILY TRAFFIC TRENDS

AVERAGE WEEKDAY SPEED DISTRIBUTIONS, EASTERN SECTION

FIGURE 2-AE

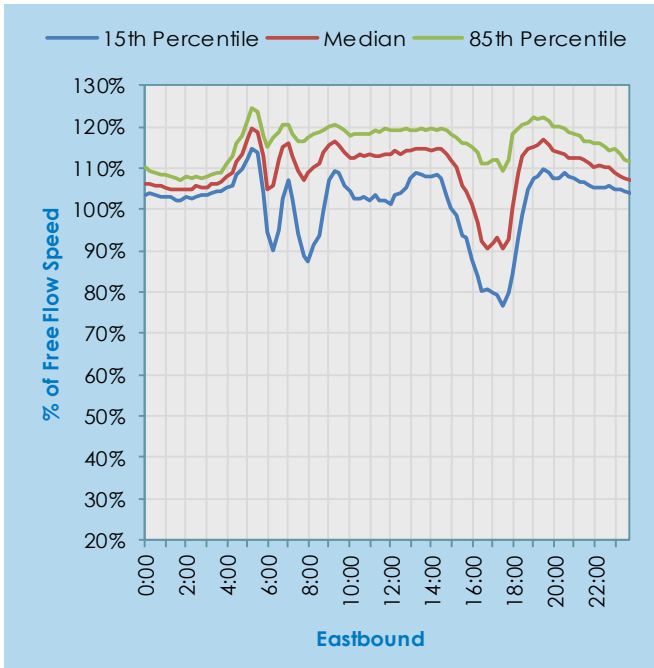
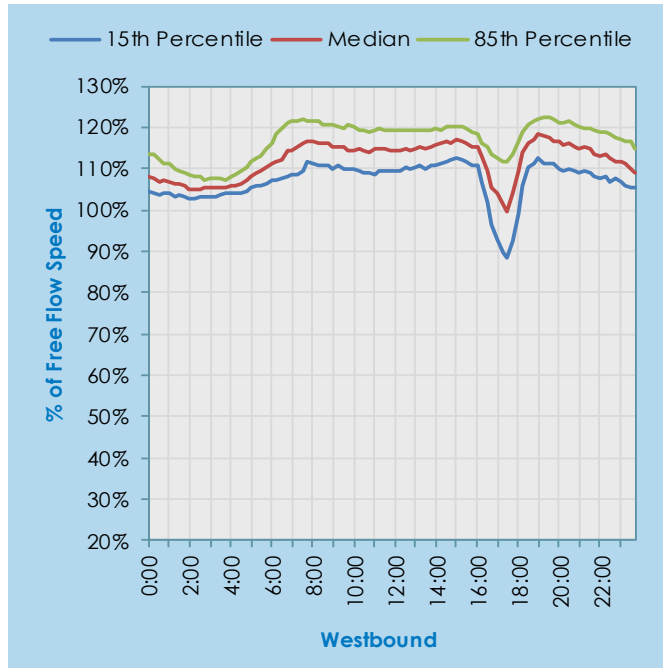

FIGURE 2-AF



AVERAGE WEEKDAY SPEED DISTRIBUTIONS, WESTERN SECTION

FIGURE 2-AG

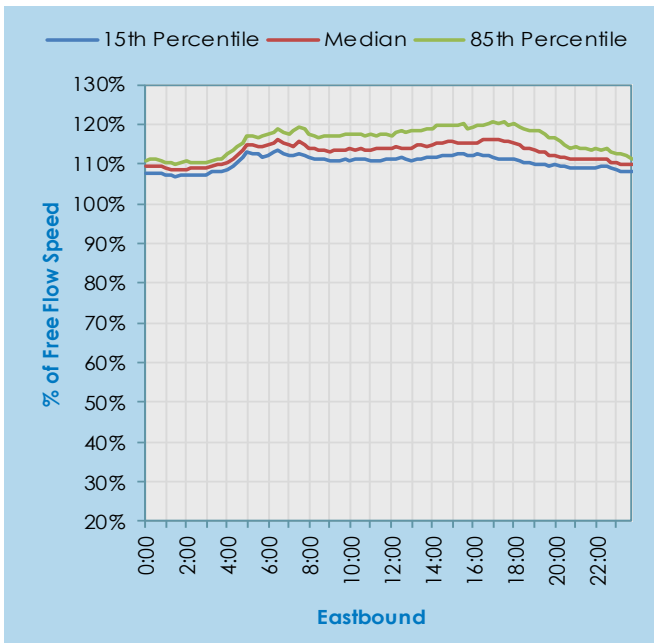
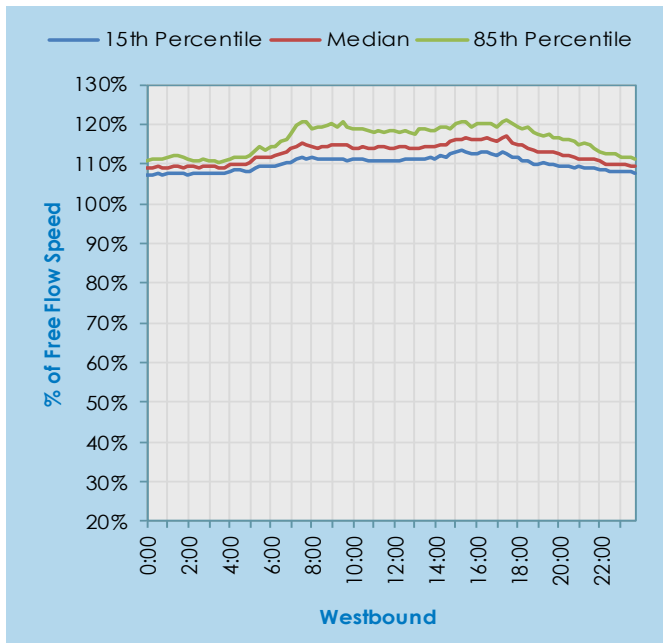
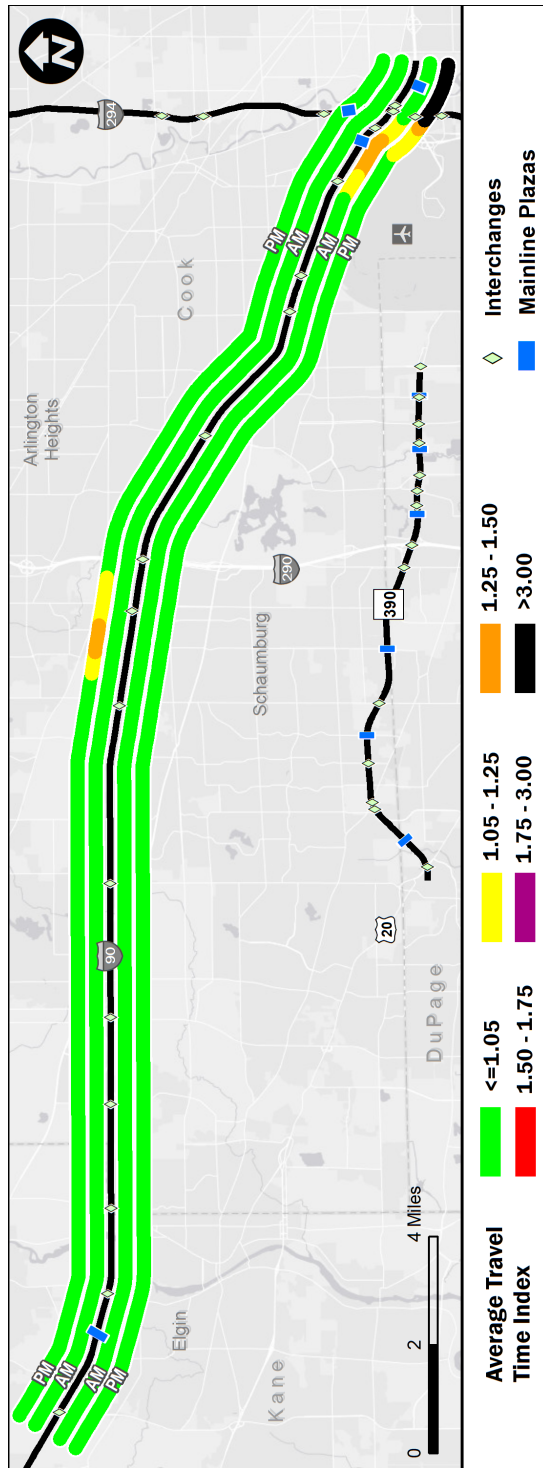

FIGURE 2-AH





Quarter	Range	Average Speed (mph)		Average Travel Time Index		Planning Time Index		Total Delay (veh-hrs / 1000 VMT)		Average Daily Delay (veh-hrs)		Percent Congested Travel	
		AM	PM	AM	PM	AM	PM	AM	PM	AM	PM	AM	PM
1	January-March	64	68	0.94	0.88	1.28	0.96	0.7	0.5	422	348	9	6
2	April-June	61	64	0.99	0.94	1.14	1.05	1.6	1.2	1,015	869	7	10
3	July-September	67	66	0.90	0.91	1.00	1.01	0.5	0.5	329	279	7	6
4	October-December	61	63	0.98	0.95	1.10	1.05	1.7	1.0	1,158	733	10	10
Total	2018 Entire Year	63	65	0.95	0.92	1.13	1.02	1.1	0.8	731	557	8	8

Data source: INRIX. Roadway performance measures sections and terms are defined on pages 1-4 and 1-5.

FIGURE 2-AI: ROADWAY PERFORMANCE MEASURES—EASTERN SECTION

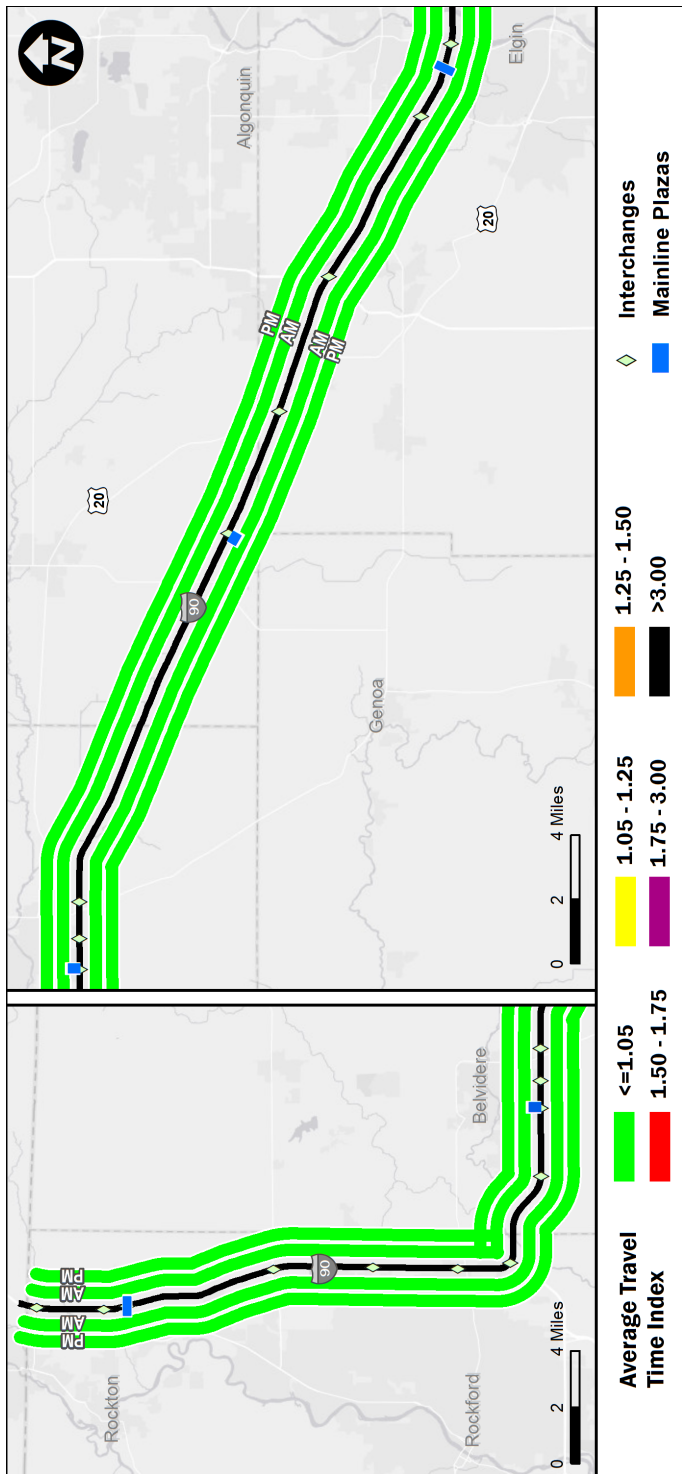

Quarter	Range	Average Speed (mph)		Average Travel Time Index		Planning Time Index		Total Delay (veh-hrs / 1000 VMT)		Average Daily Delay (veh-hrs)		Percent Congested Travel	
		AM	PM	AM	PM	AM	PM	AM	PM	AM	PM		
1	January-March	67	70	0.89	0.85	0.95	0.88	0.1	0.0	29	5	2	0
2	April-June	68	71	0.88	0.85	0.92	0.87	0.0	0.1	27	49	1	0
3	July-September	69	68	0.87	0.88	0.89	0.90	0.0	0.0	8	10	0	0
4	October-December	70	69	0.86	0.87	0.88	0.90	0.0	0.0	10	1	0	0
Total	2018 Entire Year	68	70	0.88	0.86	0.91	0.89	0.0	0.0	18	16	1	0

Data source: INRIX. Roadway performance measures sections and terms are defined on pages 1-4 and 1-5.

FIGURE 2-AJ: ROADWAY PERFORMANCE MEASURES—WESTERN SECTION

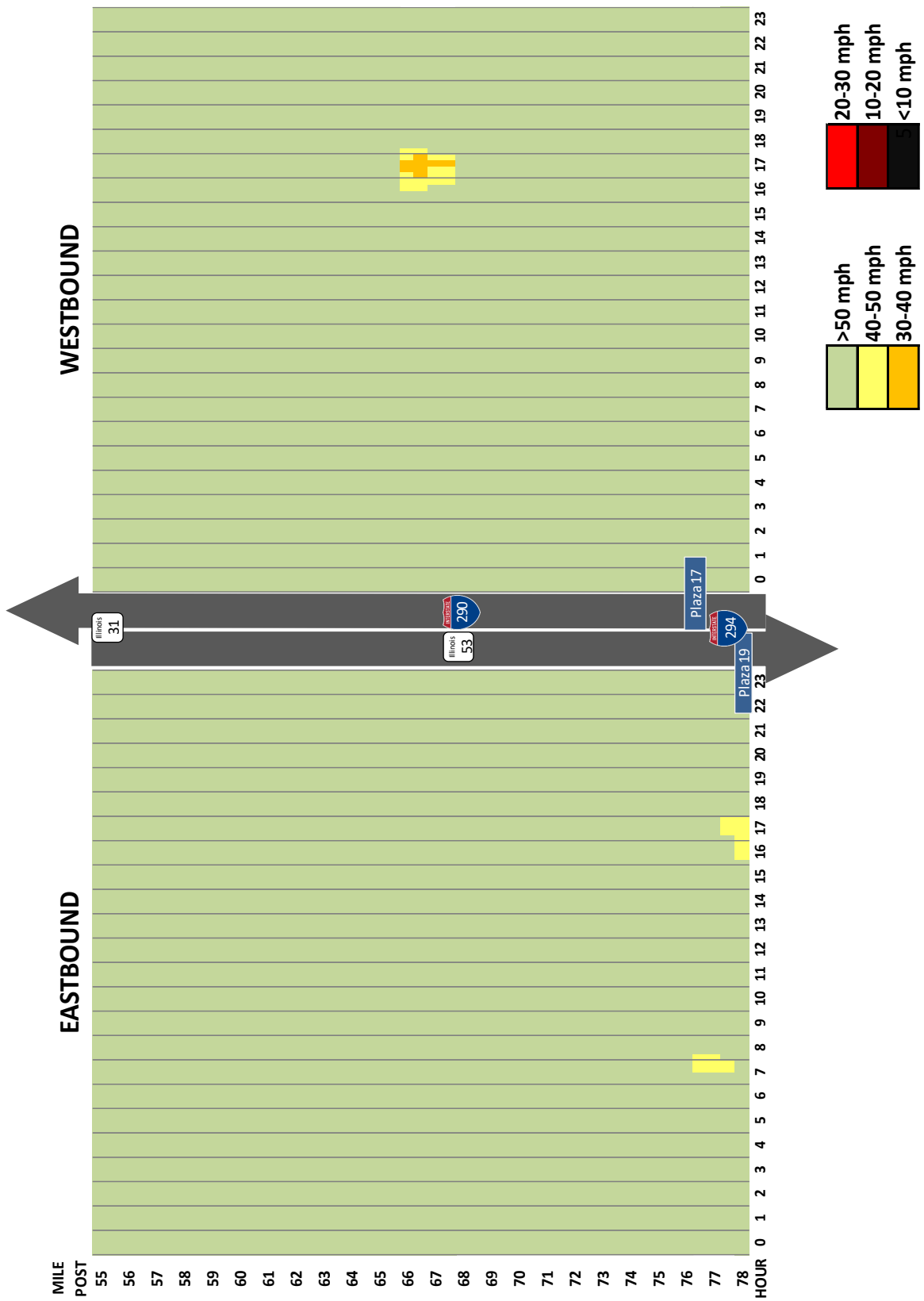
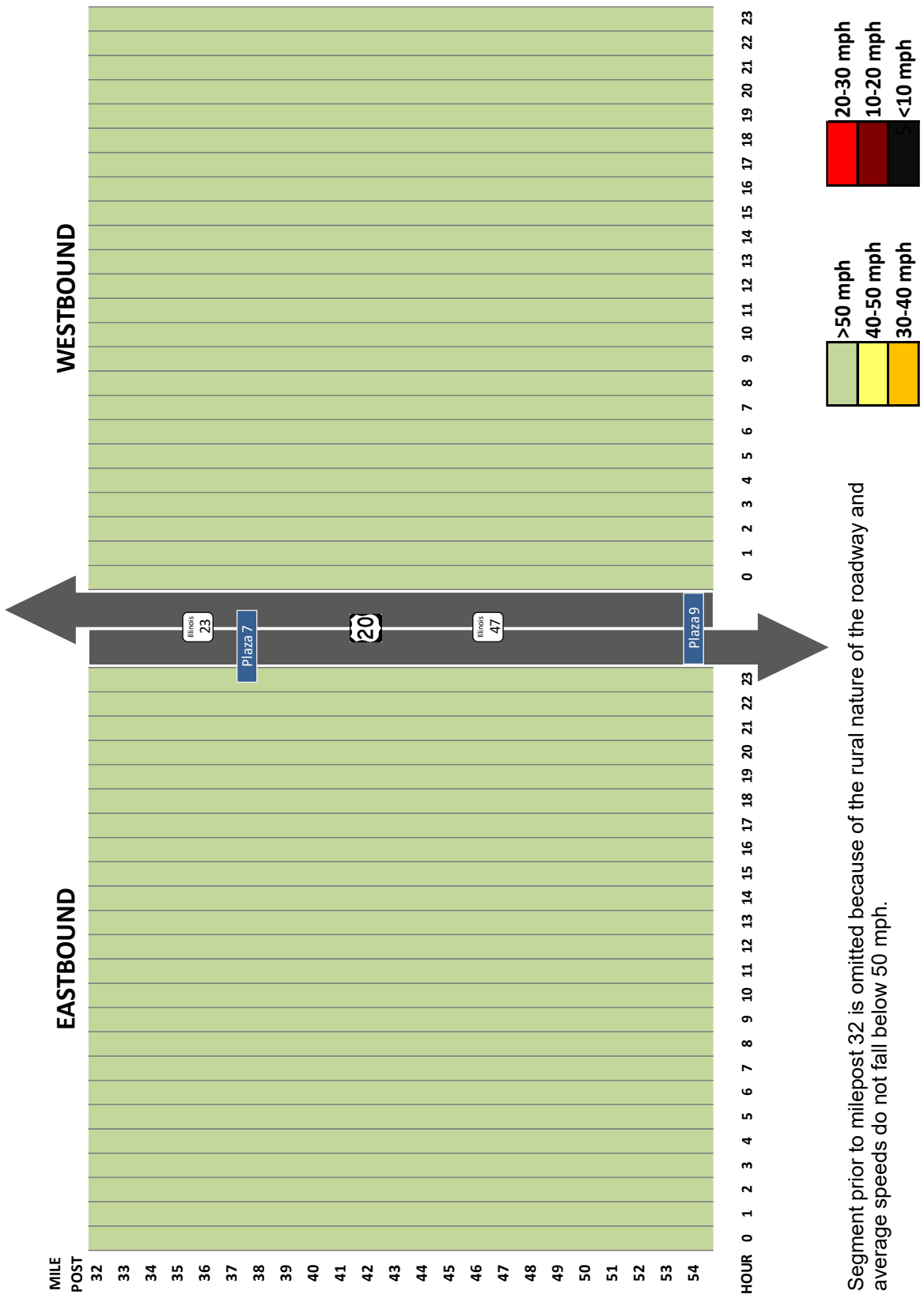

FIGURE 2-AK: AVERAGE SPEED CONTOURS MP 55.0 TO 78.5



Segment prior to milepost 32 is omitted because of the rural nature of the roadway and average speeds do not fall below 50 mph.

FIGURE 2-AL: AVERAGE SPEED CONTOURS MP 32.0 TO 54.5

Tri-State Tollway

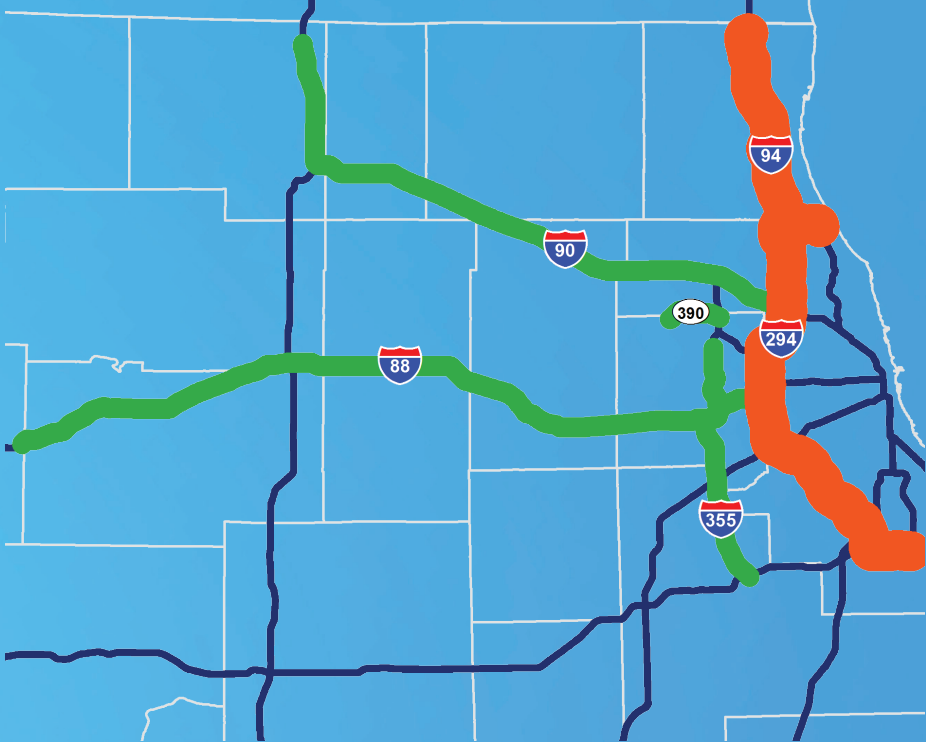

Tri-State Tollway



SECTION 3 Tri-State Tollway

TABULATIONS TABLE

	PAGE
3-A Average Daily Traffic Volumes Between Interchanges 1980 – 2018 (Northbound-1)	3-4
3-B Average Daily Traffic Volumes Between Interchanges 1980 – 2018 (Northbound-2)	3-5
3-C Average Daily Traffic Volumes Between Interchanges 1980 – 2018 (Southbound-1)	3-6
3-D Average Daily Traffic Volumes Between Interchanges 1980 – 2018 (Southbound-2)	3-7
3-E General Statistics for Mainline Plazas	3-8
3-F Indexed Monthly Variation by Mainline Plaza	3-10
3-G Indexed Daily Variation by Mainline Plaza	3-10
3-H Annual Total Transactions by Toll Plaza	3-11
3-I Average Daily Traffic Data	3-12

ILLUSTRATIONS FIGURE

	PAGE
3-A Mainline Plaza Highest Hourly Volume Plaza 21 NB	3-13
3-B Mainline Plaza Highest Hourly Volume Plaza 21 SB	3-13
3-C Mainline Plaza Highest Hourly Volume Plaza 24 EB	3-13
3-D Mainline Plaza Highest Hourly Volume Plaza 24 WB	3-13
3-E Mainline Plaza Highest Hourly Volume Plaza 29 NB	3-14
3-F Mainline Plaza Highest Hourly Volume Plaza 33 SB	3-14
3-G Mainline Plaza Highest Hourly Volume Plaza 35 NB	3-14
3-H Mainline Plaza Highest Hourly Volume Plaza 35 SB	3-14
3-I Mainline Plaza Highest Hourly Volume Plaza 36 SB	3-15
3-J Mainline Plaza Highest Hourly Volume Plaza 39 NB	3-15
3-K Mainline Plaza Highest Hourly Volume Plaza 41 NB	3-15
3-L Mainline Plaza Highest Hourly Volume Plaza 41 SB	3-15
3-M Average Daily Traffic Trends Plaza 20 Buckley Road	3-16
3-N Average Daily Traffic Trends Plaza 21 Waukegan	3-16
3-O Average Daily Traffic Trends Plaza 22 Townline Road	3-16
3-P Average Daily Traffic Trends Plaza 23 Half Day Road	3-17
3-Q Average Daily Traffic Trends Plaza 24 Edens Spur	3-17



SECTION 3 Tri-State Tollway

ILLUSTRATIONS (CONTINUED) FIGURE

PAGE

3-R	Average Daily Traffic Trends Plaza 25 Deerfield Road	3-17
3-S	Average Daily Traffic Trends Plaza 26 Lake Cook Road	3-18
3-T	Average Daily Traffic Trends Plaza 27 Willow Road	3-18
3-U	Average Daily Traffic Trends Plaza 28 Golf Road	3-18
3-V	Average Daily Traffic Trends Plaza 29 Touhy Avenue	3-19
3-W	Average Daily Traffic Trends Plaza 30 Balmoral Avenue	3-19
3-X	Average Daily Traffic Trends Plaza 31 O'Hare West	3-19
3-Y	Average Daily Traffic Trends Plaza 32 O'Hare East	3-20
3-Z	Average Daily Traffic Trends Plaza 33 Irving Park Road	3-20
3-AA	Average Daily Traffic Trends Plaza 34 Willow Springs Road	3-20
3-AB	Average Daily Traffic Trends Plaza 35 Cermak Road	3-21
3-AC	Average Daily Traffic Trends Plaza 37 I-55	3-21
3-AD	Average Daily Traffic Trends Plaza 38 95th Street	3-21
3-AE	Average Daily Traffic Trends Plaza 36 & 39 (82nd Street & 83rd Street)	3-22
3-AF	Average Daily Traffic Trends Plaza 40 159th Street	3-22
3-AG	Average Daily Traffic Trends Plaza 41 163rd Street	3-22
3-AH	Average Daily Traffic Trends Plaza 42 I-57, 147th Street	3-23
3-AI	Average Daily Traffic Trends Plaza 43 & 45 I-80	3-23
3-AJ	Average Daily Traffic Trends Plaza 47 Halsted Street	3-23
3-AK	Average Weekday Speed Distributions, Northern Section—Eastbound	3-24
3-AL	Average Weekday Speed Distributions, Northern Section—Westbound	3-24
3-AM	Average Weekday Speed Distributions, North Central Section—Northbound	3-24
3-AN	Average Weekday Speed Distributions, North Central Section—Southbound	3-24
3-AO	Average Weekday Speed Distributions, South Central Section—Northbound	3-25
3-AP	Average Weekday Speed Distributions, South Central Section—Southbound	3-25
3-AQ	Average Weekday Speed Distributions, Southern Section—Northbound	3-25
3-AR	Average Weekday Speed Distributions, Southern Section—Southbound	3-25
3-AS	Roadway Performance Measures, Northern Section	3-26
3-AT	Roadway Performance Measures, North Central Section	3-27
3-AU	Roadway Performance Measures, South Central Section	3-28



SECTION 3 Tri-State Tollway

ILLUSTRATIONS (CONTINUED) FIGURE

PAGE

3-AV Roadway Performance Measures, Southern Section	3-29
3-AW Average Speed Contours, I-94 MP 0.0 to 29.5	3-30
3-AX Average Speed Contours, I-294 MP 24.5 to 52.5	3-31
3-AY Average Speed Contours, I-294 MP 0.5 to 24.0	3-32

TABLE 3-A: AVERAGE DAILY TRAFFIC VOLUMES BETWEEN INTERCHANGES 1980-2018 (NORTHBOUND-1)

Location	Mile Post	Miles Btwn. Int.	ADT 1980	Average Annual Percent Change	ADT 1990	Average Annual Percent Change	ADT 2000	Average Annual Percent Change	ADT 2010	Average Annual Percent Change	ADT 2018
Bishop Ford Freeway/Calumet Expy	0.0										
		0.8	32,090	5.0	52,400	1.4	60,000	2.2	74,800	2.4	90,750
Lincoln Oasis	0.8										
		1.9	32,090	5.0	52,400	1.4	60,000	2.2	74,800	2.4	90,750
Halsted Street (PL47)	2.7										
		1.3	30,070	5.1	49,550	1.2	55,610	2.8	73,290	2.1	86,320
Wood Street	4.0										
		0.2	32,700	5.1	53,610	0.8	57,980	2.8	76,610	2.1	90,440
Dixie Highway	4.2										
		0.9	32,700	5.1	53,610	0.8	57,980	2.8	76,610	2.1	90,440
I-80 (PL43 & 45)	5.1										
Toll Plaza 41	5.6	1.2	25,440	4.9	40,940	-0.4	39,520	2.4	49,880	1.4	55,650
159th Street (PL40)	6.3										
		1.7	24,250	4.9	39,250	1.6	45,790	1.0	50,740	1.2	55,980
I-57/147th Street	8.0										
		4.0	24,250	4.9	39,250	1.6	45,790	1.0	50,740	5.2	76,270
Cicero Avenue (Illinois Route 50)	12.0										
		5.5	26,970	4.9	43,610	2.9	58,210	-0.3	56,490	4.1	78,020
95th Street (PL38)	17.5										
Toll Plaza 39	19.5	2.8	35,890	4.2	53,970	2.8	70,920	-0.7	66,260	2.9	83,080
79th Street/Archer Avenue	20.3										
		1.7	33,380	4.2	50,370	3.5	70,920	-0.7	66,260	2.9	83,070
Willow Springs Road (PL34)	22.0										
		1.1	33,380	4.2	50,370	3.5	71,300	-0.7	66,630	2.9	83,470
I-55 EB	23.1										
		0.2	31,230	4.2	47,190	3.4	65,740	-0.4	63,070	2.4	76,540
Wolf Road & I-55 WB	23.3										
		0.8	28,380	3.8	41,260	2.8	54,250	0.2	55,330	1.8	63,630
Toll Plaza 37 (I-55)	24.1										
		0.9	45,400	3.3	62,620	2.0	76,420	0.8	83,150	1.3	92,100
Hinsdale Oasis	25.0										
		2.4	45,400	3.3	62,620	2.4	79,570	0.8	86,270	1.3	95,620
Ogden Avenue (U.S. Route 34)	27.4										
		1.6	44,710	3.5	62,980	2.1	77,300	1.0	85,260	1.3	94,580
Reagan Connector	29.0										
		0.5	37,610	2.8	49,760	2.2	62,050	0.6	66,010	1.3	73,350
Cermak Road	29.5										
Toll Plaza 35	29.9	1.0	39,360	2.9	52,420	2.4	66,410	0.3	68,280	1.7	78,200
Roosevelt Road (IL38)	30.5										
		0.6	37,590	2.9	49,900	2.1	61,270	0.6	64,930	1.6	73,730
Reagan Memorial Tollway (I-88)	31.1										
		0.5	44,050	0.8	47,710	1.2	53,500	1.9	64,820	0.9	69,670
Eisenhower Expressway (I-290)	31.6										
		2.0	40,130	2.5	51,370	1.7	60,900	1.3	69,560	1.3	76,980
Illinois Route 64 & U.S. Route 20	33.6										
		4.2	47,320	2.6	61,300	1.9	74,020	1.0	81,990	1.3	90,580
O'Hare Oasis	37.8										
		0.5	47,320	2.6	61,300	1.9	74,020	1.0	81,990	1.3	90,580
Irving Park Road (Illinois Route 19)	38.3										
Toll Plaza 33	38.9	1.5	53,050	3.1	71,830	1.7	85,080	1.0	93,650	1.3	103,870
Balmoral Avenue	39.8										

TABLE 3-B: AVERAGE DAILY TRAFFIC VOLUMES BETWEEN INTERCHANGES 1980-2018 (NORTHBOUND-2)

Location	Mile Post	Miles Btwn. Int.	ADT 1980	Average Annual Percent Change	ADT 1990	Average Annual Percent Change	ADT 2000	Average Annual Percent Change	ADT 2010	Average Annual Percent Change	ADT 2018
Balmoral Avenue	39.8										
Kennedy Expressway (I-190)	40.5	1.1	53,050	3.1	71,830	1.7	85,080	1.0	93,650	-0.2	92,090
Jane Addams Interchange	40.9										
Toll Plaza 29	41.6	1.2	45,770	4.1	68,690	2.0	83,800	-0.1	82,840	2.0	97,160
Touhy Avenue	42.1										
		2.1	39,730	4.3	60,690	2.1	74,390	0.3	76,590	1.6	86,840
Dempster Street (U.S. Route 14)	44.2										
		1.0	29,250	4.0	43,230	2.4	55,050	0.1	55,450	1.8	63,810
Golf Road (Illinois Route 58)	45.2										
		3.7	33,080	4.3	50,550	2.3	63,640	0.0	63,340	1.7	72,670
Willow Road (PL27)	48.9										
		3.9	21,750	6.6	41,210	2.9	55,010	0.1	55,480	1.6	63,040
Lake Cook Road	52.8										
Edens Spur	30.0										
		2.3	8,120	8.5	18,300	2.3	22,880	-0.7	21,420	0.0	21,410
Waukegan Road	27.7										
		2.5	10,350	7.2	20,760	1.9	25,010	-0.3	24,280	0.5	25,200
Tri-State Tollway	25.2										
Lake Cook Road / I-94 / I-294	25.2										
		1.0	32,100	6.0	57,460	2.0	69,970	0.9	76,390	1.5	86,040
Deerfield Road	24.2										
		2.4	29,180	5.6	50,360	2.3	63,280	1.4	72,870	1.7	83,250
Half Day Road (Illinois Route 22/PL 23)	21.8										
		2.9	28,600	5.5	48,980	2.5	62,960	0.8	68,200	1.9	79,290
Town Line Road (Illinois Route 60/PL 22)	18.9										
		0.8	26,050	5.8	45,830	2.9	61,020	0.2	62,510	1.8	72,320
Lake Forest Oasis	18.1										
		2.1	26,050	5.8	45,830	2.9	61,020	0.2	62,510	1.8	72,320
Rockland Avenue (Illinois Route 176)	16.0										
		2.2	24,220	5.6	41,940	3.1	56,670	0.3	58,280	1.6	66,410
Buckley Road (Illinois Route 137)	13.8										
		2.6	22,310	5.5	38,070	3.3	52,860	0.3	54,570	1.5	61,350
Belvidere Road (Illinois Route 120)	11.2										
		1.1	18,840	5.1	31,010	3.2	42,380	0.5	44,450	0.7	46,970
Milwaukee Avenue (Illinois Route 21)	10.1										
		1.7	19,580	5.2	32,400	3.3	44,640	0.6	47,290	1.0	51,130
Grand Avenue (Illinois Route 132)	8.4										
Toll Plaza 21	4.8	6.0	13,440	5.6	23,220	2.8	30,650	0.4	31,920	2.7	39,380
Rosecrans Road (Illinois Route 173)	2.4										
		1.2	12,580	5.4	21,250	2.6	27,590	0.3	28,340	2.6	34,750
Mill Creek Road	1.2										
		0.4	12,580	5.4	21,250	2.6	27,590	0.3	28,340	2.6	34,750
Skokie Highway (U.S. Route 41)	0.8										



TABLE 3-C: AVERAGE DAILY TRAFFIC VOLUMES BETWEEN INTERCHANGES 1980-2018 (SOUTHBOUND-1)

Location	Mile Post	Miles Btwn. Int.	ADT 1980	Average Annual Percent Change	ADT 1990	Average Annual Percent Change	ADT 2000	Average Annual Percent Change	ADT 2010	Average Annual Percent Change	ADT 2018
Bishop Ford Freeway/Calumet Expy	0.0										
		0.8	32,160	4.9	51,770	0.9	56,630	2.9	75,700	2.0	88,800
Lincoln Oasis	0.8										
		1.9	32,160	4.9	51,770	0.9	56,630	2.9	75,700	2.0	88,800
Halsted Street (Pl 47)	2.7										
		1.3	30,260	5.0	49,300	0.8	53,380	3.1	72,100	2.0	84,170
Wood Street	4.0										
		0.2	30,260	5.0	49,300	0.8	53,380	3.1	72,100	2.0	84,170
Dixie Highway	4.2										
		0.9	33,000	4.9	53,370	0.7	57,100	2.9	75,790	1.8	87,280
I-80 (Pl 43 & 45)	5.1										
Toll Plaza 41	5.6	1.2	25,850	4.7	40,770	-0.4	39,050	2.4	49,600	1.3	55,100
159th Street (Pl46)	6.3										
		1.7	24,400	4.8	39,050	1.2	44,180	1.2	49,570	1.3	55,110
I-57/147th Street	8.0										
		4.0	24,400	4.8	39,050	1.2	44,180	1.2	49,570	5.1	73,900
Cicero Avenue (Illinois Route 50)	12.0										
		5.5	27,290	4.6	42,590	2.8	56,350	-0.4	54,280	4.4	76,440
95th Street (U.S. Routes 12&20)	17.5										
Toll Plaza 36	19.5	2.8	35,750	4.0	53,170	2.9	70,920	-0.5	67,510	3.1	86,440
79th Street/Archer Avenue	20.3										
		1.7	30,530	4.0	45,290	3.8	65,790	-0.4	63,000	2.7	78,190
Willow Springs Road/75th Street	22.0										
		1.1	30,530	4.0	45,290	4.1	67,370	-0.4	64,420	2.4	77,730
Interstate 55 (No SB Ramps)	23.1										
		0.2	30,530	4.0	45,290	4.1	67,370	-0.4	64,420	0.6	67,320
Wolf Road & NB I-55 Entrance	23.3										
		0.8	27,460	3.3	37,980	3.6	54,270	0.2	55,200	2.5	67,320
Interstate 55	24.1										
		0.9	45,140	3.0	60,840	2.9	80,730	0.6	86,050	1.9	99,750
Hinsdale Oasis	25.0										
		2.4	45,140	3.0	60,840	2.9	80,730	0.6	86,050	1.9	99,750
Ogden Avenue (U.S. Route 34)	27.4										
		1.6	44,450	3.2	60,940	2.9	80,940	0.6	86,180	1.6	97,670
Reagan Connector	29.0										
		0.5	37,400	2.5	47,760	3.7	68,440	-0.2	67,060	1.2	73,600
Cermak Road	29.5										
Toll Plaza 35	29.9	1.0	39,160	2.5	50,330	3.6	71,370	-0.3	69,070	1.6	78,160
Roosevelt Road (Illinois Route 38)	30.5										
		0.6	37,330	2.6	48,030	3.5	67,520	-0.4	65,020	1.3	72,380
Reagan Memorial Tollway (I-88)	31.1										
		0.5	43,340	4.2	65,600	2.9	87,710	0.4	91,100	0.9	98,180
Eisenhower Expressway (I-290)	31.6										
		2.0	39,180	2.5	50,360	3.4	70,590	0.6	74,620	1.3	82,830
Illinois Route 64 & U.S. Route 20	33.6										
		4.2	46,280	2.7	60,310	3.2	82,840	0.3	85,070	1.4	95,030
O'Hare Oasis	37.8										
		0.5	46,280	2.7	60,310	3.2	82,840	0.3	85,070	1.4	95,030
Irving Park Road (Illinois Route 19)	38.3										
Toll Plaza 33	38.9	1.5	51,960	3.2	70,940	2.9	94,270	0.2	96,260	1.2	105,610
Balmoral Avenue	39.8										



TABLE 3-D: AVERAGE DAILY TRAFFIC VOLUMES BETWEEN INTERCHANGES 1980-2018 (SOUTHBOUND-2)

Location	Mile Post	Miles Btwn. Int.	ADT 1980	Average Annual Percent Change	ADT 1990	Average Annual Percent Change	ADT 2000	Average Annual Percent Change	ADT 2010	Average Annual Percent Change	ADT 2018
Balmoral Avenue	39.8										
	40.5	1.1	51,960	3.2	70,940	2.6	91,700	-0.2	90,200	1.1	98,510
O'Hare Interchange (I-90/I-294/I-190)	40.9										
Toll Plaza 29	41.6	1.2	45,980	4.5	71,500	1.0	79,140	-0.1	78,040	2.8	97,190
Touhy Avenue	42.1										
		2.1	39,940	4.8	63,660	0.9	69,290	-0.1	68,920	3.0	87,180
Dempster Street (U.S. Route 14)	44.2										
		1.0	29,520	4.6	46,460	0.6	49,170	0.0	49,030	3.1	62,540
Golf Road (Illinois Route 58)	45.2										
		3.7	33,480	4.8	53,510	0.8	57,890	-0.1	57,080	2.9	71,590
Willow Road (PL27)	48.9										
		3.9	22,130	7.2	44,410	1.2	50,280	0.3	51,810	2.8	64,700
Lake Cook Road	52.8										
Edens Expressway	30.0										
		2.3	8,500	8.0	18,420	2.3	23,100	-0.6	21,800	-2.8	17,400
Waukegan Road	27.7										
		2.5	10,230	7.3	20,760	2.0	25,310	-0.1	25,010	0.2	25,510
Lake Cook Road / I-94 / I-294	25.2										
Lake Cook Road / I-94 / I-294	25.2										
		1.0	32,360	6.5	60,480	1.6	70,900	0.8	76,560	2.5	93,400
Deerfield Road	24.2										
		2.4	29,260	6.2	53,160	2.0	64,960	0.7	69,920	2.6	85,880
Half Day Road (Illinois Route 22/PL23)	21.8										
		2.9	28,440	6.1	51,480	2.3	64,320	0.3	66,210	2.4	80,120
Town Line Road (Illinois Route 60/PL22)	18.9										
		0.8	25,900	6.4	48,000	2.6	62,080	-0.2	61,150	2.1	72,320
Lake Forest Oasis	18.1										
		2.1	25,900	6.4	48,000	2.6	62,080	-0.2	61,150	2.1	72,320
Rockland Road (Illinois Route 176)	16.0										
		2.2	24,080	6.2	43,780	2.8	57,680	0.0	57,430	1.8	66,160
Buckley Road (Illinois Route 137/PL20)	13.8										
		2.6	22,100	6.0	39,560	3.0	53,310	0.0	53,370	1.4	59,640
Belvidere Road (Illinois Route 120)	11.2										
		1.1	18,770	5.6	32,240	2.7	41,900	0.4	43,600	0.7	46,150
Milwaukee Avenue (Illinois Route 21)	10.1										
		1.7	19,580	5.5	33,590	2.8	44,350	0.5	46,680	1.0	50,700
Grand Avenue (Illinois Route 132)	8.4										
Toll Plaza 21	4.8	6.0	13,520	5.8	23,690	2.8	31,270	0.5	32,730	2.5	39,830
Rosecrans Road (Illinois Route 173)	2.4										
		1.2	12,380	5.8	21,740	2.5	27,960	0.3	28,800	2.4	34,810
U.S. Route 41	1.2										
		0.4	11,410	5.7	19,830	2.8	26,110	3.4	36,630	2.8	45,770
Russell Road (West Terminus)	0.8										



**TABLE 3-E: GENERAL STATISTICS FOR MAINLINE PLAZAS
(Vehicles/Hour)**

Mainline Plaza	Dir.	30th HV	Period	Mean	Med.	Max.	Min.	Std. Dev.	85th %
21 Waukegan	NB	4,310	AM Peak	1,675	1,679	2,140	996	199	1,872
			PM Peak	3,522	3,557	4,379	2,110	275	3,776
			OFF Peak	1,410	1,425	3,997	147	866	2,356
			Weekend	1,690	1,616	5,080	90	1,109	2,911
			Holidays	1,572	1,420	4,488	88	1,128	2,915
	SB	4,406	AM Peak	3,191	3,264	3,730	1,566	287	3,428
			PM Peak	2,041	2,034	2,702	1,104	213	2,259
			OFF Peak	1,435	1,593	3,300	144	825	2,335
			Weekend	1,698	1,735	5,188	143	1,088	2,867
			Holidays	1,633	1,566	4,876	132	1,123	2,761
24 Edens Spur	EB	2,782	AM Peak	2,017	2,154	3,005	621	550	2,658
			PM Peak	1,636	1,725	2,127	849	276	1,916
			OFF Peak	950	1,061	2,723	21	626	1,579
			Weekend	1,033	1,149	2,904	63	642	1,720
			Holidays	903	969	2,609	63	564	1,446
	WB	2,858	AM Peak	1,512	1,382	2,292	507	385	2,050
			PM Peak	2,115	2,289	3,023	1,048	526	2,685
			OFF Peak	955	990	2,815	58	656	1,634
			Weekend	1,003	1,000	3,103	61	637	1,637
			Holidays	853	811	2,865	39	585	1,488
29 Touhy Avenue	NB	8,688	AM Peak	7,704	7,726	8,998	3,480	791	8,473
			PM Peak	7,374	7,409	8,542	5,027	548	7,930
			OFF Peak	3,696	4,197	8,558	280	2,226	6,031
			Weekend	3,727	3,950	8,514	346	2,143	6,032
			Holidays	3,347	3,402	8,132	306	2,025	5,592
33 Irving Park Road	SB	8,414	AM Peak	7,025	6,993	8,862	3,108	877	7,964
			PM Peak	7,024	6,994	8,465	4,040	615	7,718
			OFF Peak	4,154	4,756	8,269	243	2,418	6,702
			Weekend	4,157	4,424	8,622	429	2,294	6,659
			Holidays	3,659	3,688	7,668	366	2,131	6,245



**TABLE 3-E: GENERAL STATISTICS FOR MAINLINE PLAZAS
(Vehicles/Hour)**

Mainline Plaza	Dir.	30th HV	Period	Mean	Med.	Max.	Min.	Std. Dev.	85th %
35 Cermak Road	NB	5,998	AM Peak	5,125	5,164	6,345	1,700	659	5,740
			PM Peak	5,002	5,010	5,945	3,122	458	5,453
			OFF Peak	3,024	3,453	6,598	321	1,688	4,832
			Weekend	3,154	3,294	6,304	342	1,751	5,122
			Holidays	2,845	2,866	5,696	335	1,639	4,784
	SB	5,770	AM Peak	4,695	4,753	5,559	2,018	618	5,268
			PM Peak	4,466	4,504	5,297	2,320	362	4,804
			OFF Peak	3,136	3,418	5,994	47	1,763	5,009
			Weekend	3,137	3,237	5,983	305	1,781	5,099
			Holidays	2,802	2,856	5,739	264	1,597	4,709
36 82 nd Street	SB	7,862	AM Peak	4,607	4,566	5,657	1,330	630	5,272
			PM Peak	7,307	7,390	8,076	3,829	490	7,700
			OFF Peak	3,424	3,608	7,736	270	2,051	5,509
			Weekend	3,325	3,274	8,119	139	1,954	5,413
			Holidays	3,055	2,937	8,015	250	1,954	5,313
39 83 rd Street	NB	7,368	AM Peak	6,461	6,466	8,069	3,595	798	7,216
			PM Peak	5,236	5,282	6,244	3,038	498	5,680
			OFF Peak	3,198	3,436	7,857	375	1,936	5,194
			Weekend	3,266	3,265	7,415	124	1,912	5,409
			Holidays	3,002	2,962	6,969	306	1,811	5,137
41 163 rd Street	NB	4,590	AM Peak	4,147	4,181	4,932	2,300	380	4,512
			PM Peak	3,463	3,486	4,272	2,158	371	3,865
			OFF Peak	2,127	2,269	4,270	253	1,145	3,426
			Weekend	2,224	2,223	4,668	234	1,273	3,730
			Holidays	2,076	2,033	4,490	221	1,266	3,602
	SB	4,716	AM Peak	2,771	2,759	3,544	1,334	404	3,207
			PM Peak	4,179	4,236	4,890	2,377	327	4,468
			OFF Peak	2,195	2,325	4,719	239	1,185	3,487
			Weekend	2,171	2,138	5,084	215	1,221	3,571
			Holidays	1,999	1,979	4,515	171	1,200	3,291

AM Peak = Weekday 6:00 AM To 8:00 AM Except Fridays
 PM Peak = Weekday 4:00 PM To 6:00 PM Except Fridays
 OFF Peak = Weekdays Except Fridays and AM and PM Peak Periods
 Weekend = Fridays, Saturdays, and Sundays
 Holidays = See Page 1-6 for a list of Holidays.

TABLE 3-F: INDEXED MONTHLY VARIATION BY MAINLINE PLAZA

Month	Wau-kegan	Edens Spur	Touhy Avenue	Irving Park	Cermak Road	82nd Street	83rd Street	163rd Street
January	0.83	0.96	0.89	0.91	0.85	0.84	0.84	0.82
February	0.87	0.99	0.92	0.95	0.89	0.88	0.87	0.85
March	0.94	1.06	1.00	1.04	1.00	0.98	0.99	0.98
April	0.96	1.09	1.03	1.05	1.01	1.00	1.01	0.99
May	1.04	1.16	1.07	1.07	1.06	1.05	1.05	1.06
June	1.13	1.21	1.11	1.08	1.08	1.08	1.07	1.10
July	1.16	1.18	1.04	1.01	1.05	1.06	1.09	1.10
August	1.14	0.92	1.06	1.03	1.08	1.09	1.09	1.11
September	1.04	0.89	1.00	0.98	1.02	1.01	1.01	1.03
October	1.01	0.89	0.99	0.99	1.03	1.04	1.03	1.05
November	0.95	0.83	0.96	0.96	0.99	1.00	0.99	0.99
December	0.92	0.83	0.93	0.94	0.96	0.95	0.95	0.93

TABLE 3-G: INDEXED DAILY VARIATION BY MAINLINE PLAZA

Month	Day	Wau-kegan	Edens Spur	Touhy Avenue	Irving Park	Cermak Road	82nd Street	83rd Street	163rd Street
August	Monday	1.10	0.92	1.05	1.03	1.08	1.08	1.08	1.09
	Tuesday	1.08	0.90	1.02	1.00	1.04	1.04	1.04	1.05
	Wednesday	1.09	0.89	1.03	1.00	1.05	1.06	1.07	1.07
	Thursday	1.10	0.88	1.02	1.00	1.05	1.07	1.06	1.09
	Friday	1.11	0.88	1.03	1.00	1.04	1.07	1.07	1.08
	Saturday	1.22	0.96	1.10	1.06	1.12	1.13	1.12	1.16
	Sunday	1.27	0.99	1.11	1.11	1.15	1.14	1.15	1.19
December	Monday	0.89	0.80	0.90	0.92	0.93	0.93	0.90	0.89
	Tuesday	0.93	0.80	0.91	0.91	0.94	0.93	0.92	0.91
	Wednesday	0.99	0.84	0.97	0.98	1.01	1.01	1.02	0.99
	Thursday	0.94	0.82	0.95	0.96	0.98	0.98	1.00	0.97
	Friday	0.94	0.83	0.97	1.00	1.01	0.99	1.01	0.98
	Saturday	0.94	0.89	0.97	0.97	0.98	0.99	1.00	0.97
	Sunday	0.83	0.86	0.90	0.89	0.89	0.91	0.89	0.86

Table 3-G includes Monthly Variation

TABLE 3-H: ANNUAL TOTAL TRANSACTIONS BY TOLL PLAZA

Plaza	Plaza Code*	2017	2018	Percentage Change
20 Buckley Road	R	2,591,261	2,578,895	-0.5%
21 Waukegan	M	29,294,423	28,908,380	-1.3%
22 Illinois Route 60	R	3,784,185	3,707,404	-2.0%
23 Half Day Road	R	4,082,301	4,095,340	0.3%
24 Edens Spur	M	21,013,411	18,510,799	-11.9%
26 Lake-Cook Road	R	6,341,168	6,521,934	2.9%
27 Willow Road	R	6,310,824	6,219,787	-1.4%
28 Golf Road	R	6,586,948	6,535,631	-0.8%
29 Touhy Avenue	M1	36,476,816	35,464,224	-2.8%
30 Balmoral Avenue	E	4,468,854	4,298,900	-3.8%
31 O'Hare West	R1	9,914,290	10,249,095	3.4%
32 O'Hare East	R1	6,410,242	5,848,979	-8.8%
33 Irving Park Road	M1	40,402,666	38,548,733	-4.6%
34 Willow Springs Road	R	2,469,051	2,454,966	-0.6%
35 Cermak Road	M	56,998,187	57,072,066	0.1%
36 82nd Street	M1	30,801,569	31,547,759	2.4%
37 I-55	R	23,654,955	23,534,111	-0.5%
38 95th Street	R	6,162,501	6,278,869	1.9%
39 83rd Street	M1	30,083,072	30,323,671	0.8%
40 159th Street	R	2,371,118	1,968,056	-17.0%
41 163rd Street	M	39,558,782	40,418,672	2.2%
42 I-57	E	13,466,457	14,263,692	5.9%
43 I-80 Westbound	A1	13,176,578	13,240,294	0.5%
45 I-80 Eastbound	A1	12,381,699	12,149,990	-1.9%
47 Halsted Street	R	8,188,791	8,070,589	-1.4%
Tri-State Total		416,990,149	412,810,836	-1.0%

* M=Mainline / R=Ramp / A=Attended Ramp Plaza / E=Electronic Toll Collection Only Ramp
1=Toll Collected in One Direction Only

TABLE 3-I: AVERAGE DAILY TRAFFIC DATA

Year	Average Daily Total			Average Trip
	Vehicles	Vehicle Miles	Transactions	Length (Miles)
1959	42,944	1,074,421	87,977	25.02
1960	53,665	1,423,119	114,591	26.52
1961	63,040	1,508,414	113,413	23.93
1962	79,567	1,716,653	149,996	21.57
1963	81,865	1,538,064	135,872	18.79
1964	83,177	1,576,375	140,729	18.95
1965	96,141	1,791,966	161,958	18.64
1966	104,898	2,070,944	189,068	19.74
1967	113,248	2,264,510	211,941	20.00
1968	124,197	2,499,952	255,161	20.13
1969	145,335	2,795,118	285,279	19.23
1970	150,204	2,993,741	305,965	19.93
1971	165,910	3,324,444	340,539	20.04
1972	177,740	3,435,183	352,056	19.33
1973	196,462	3,684,032	386,527	18.75
1974	206,074	3,814,440	404,858	18.51
1975	212,313	3,815,435	407,611	17.97
1976	234,136	4,147,527	442,435	17.71
1977	252,032	4,472,743	475,766	17.75
1978	268,655	4,748,560	504,534	17.68
1979	274,714	4,870,270	520,258	17.73
1980	264,698	4,804,154	508,555	18.15
1981	279,965	4,905,922	522,890	17.52
1982	281,782	4,818,745	519,152	17.10
1983	291,652	5,001,519	532,111	17.15
1984	310,008	5,493,171	583,129	17.72
1985	327,277	5,660,998	603,292	17.30
1986	348,651	6,227,866	654,517	17.86
1987	367,191	6,233,335	685,226	16.98
1988	396,711	7,132,315	749,395	17.98
1989	410,352	7,364,825	771,395	17.95
1990	425,089	7,501,631	779,065	17.65
1991	478,355	7,607,215	797,157	15.90
1992	494,963	7,283,706	781,630	14.72
1993	499,598	7,205,338	782,631	14.42
1994	491,071	8,254,734	859,181	16.81
1995	520,320	8,814,694	916,329	16.94
1996	540,460	9,090,414	945,831	16.82
1997	562,300	9,257,833	971,481	16.46
1998	577,930	9,408,676	975,821	16.28
1999	576,220	9,404,524	893,630	16.32
2000	590,900	9,632,552	916,723	16.30
2001	601,820	9,775,171	933,313	16.24
2002	615,200	10,263,261	965,408	16.68
2003	626,950	10,515,023	989,952	16.77
2004	634,390	10,611,992	1,003,291	16.73
2005	594,220	9,982,878	936,432	16.80
2006	537,400	9,956,325	927,615	18.53
2007	563,600	10,132,520	964,388	17.98
2008	581,370	9,101,117	894,275	15.65
2009	578,140	8,992,194	886,512	15.55
2010	581,150	9,979,253	955,841	17.17
2011	595,800	10,128,377	982,468	17.00
2012	582,330	9,752,805	940,793	16.75
2013	596,490	10,242,864	973,802	17.17
2014	612,520	10,551,115	1,006,738	17.23
2015	638,240	11,335,773	1,080,908	17.76
2016	662,790	11,684,828	1,126,732	17.63
2017	672,180	11,854,283	1,142,439	17.64
2018	658,380	11,712,157	1,130,989	17.79



FIGURE 3-B

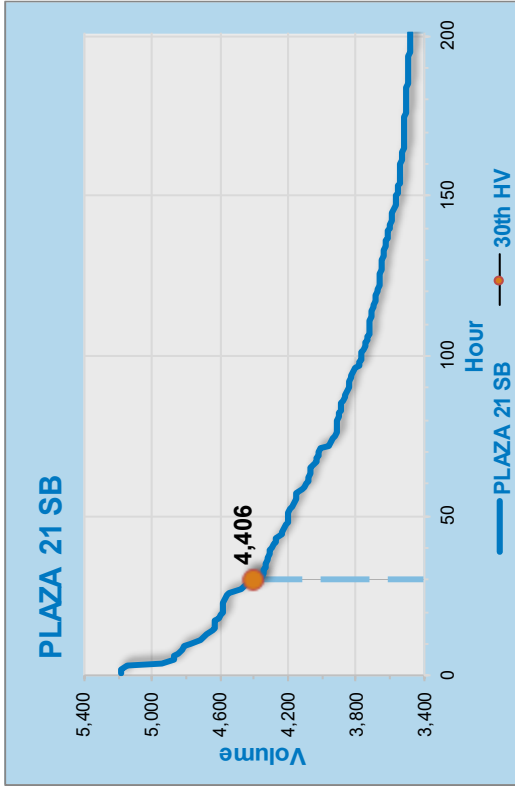

FIGURE 3-D

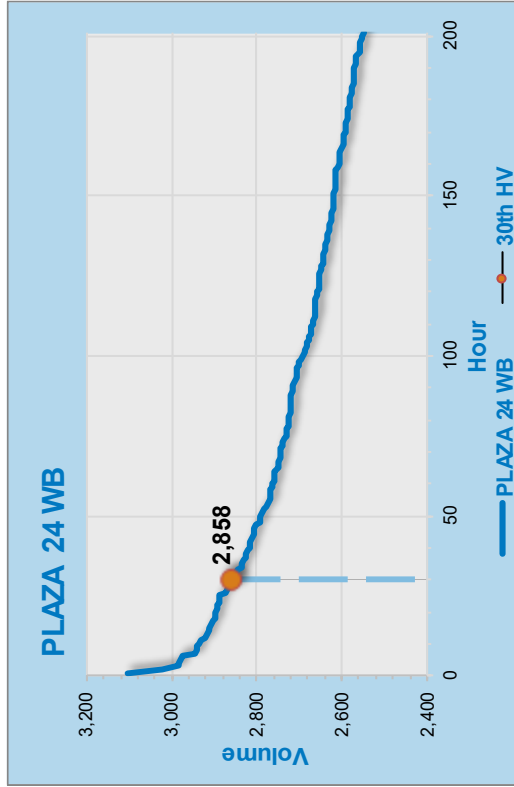

FIGURE 3-A

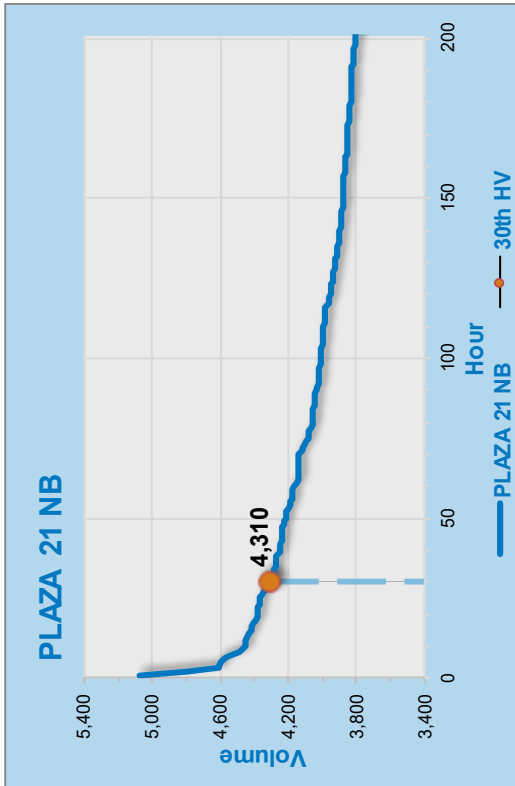
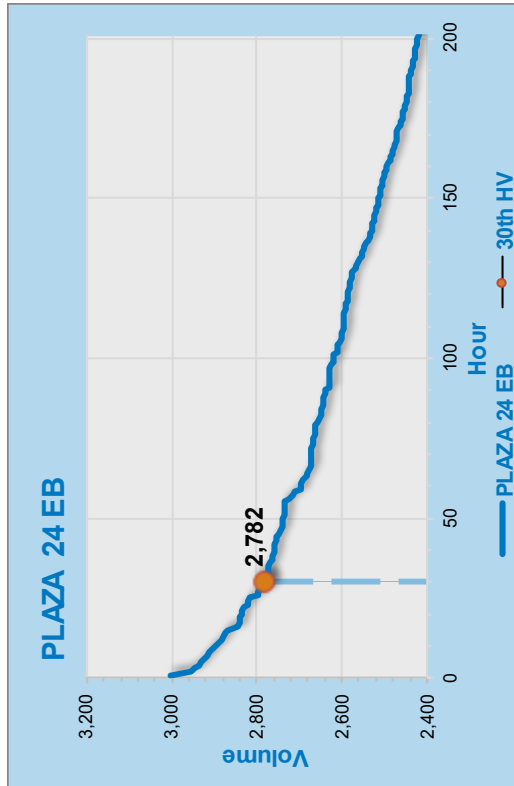

FIGURE 3-C



MAINLINE PLAZA HIGHEST HOURLY VOLUME

FIGURE 3-F

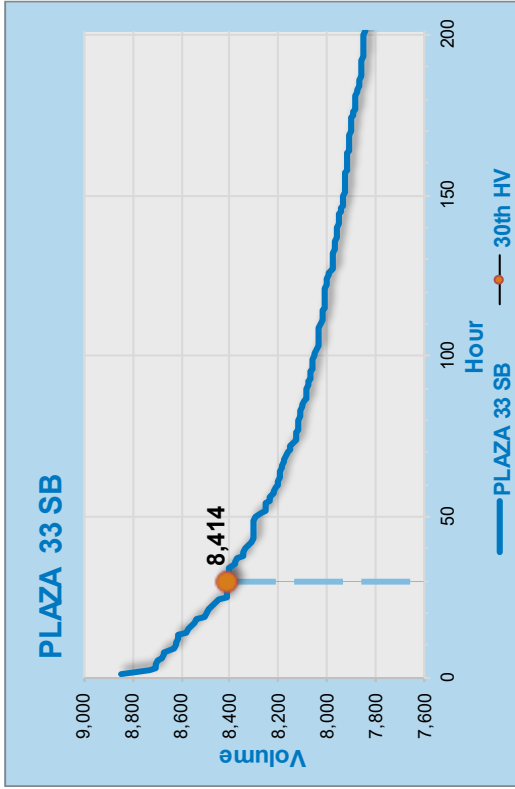

FIGURE 3-H

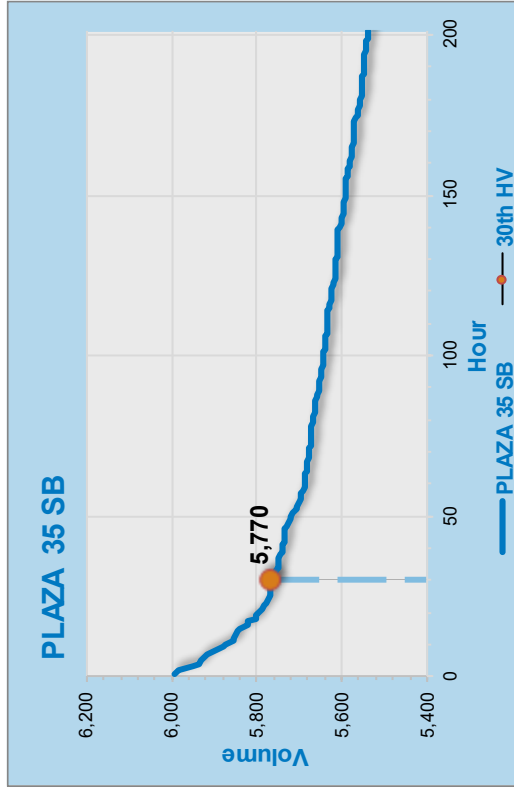

FIGURE 3-E

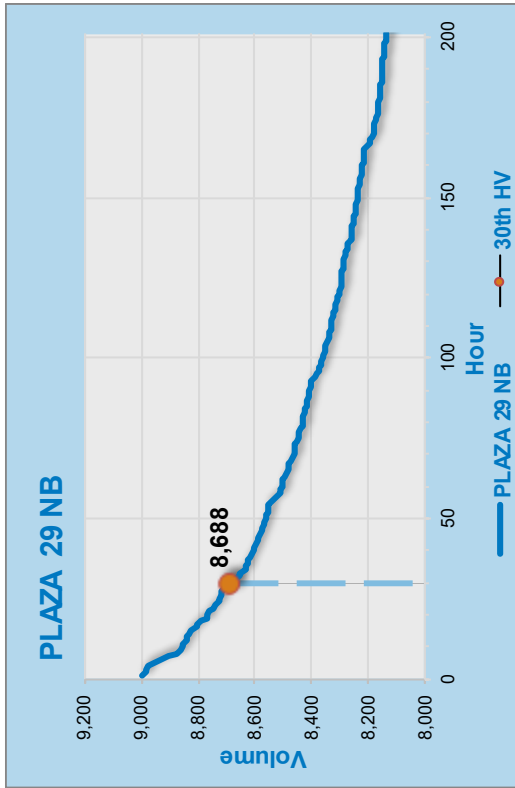
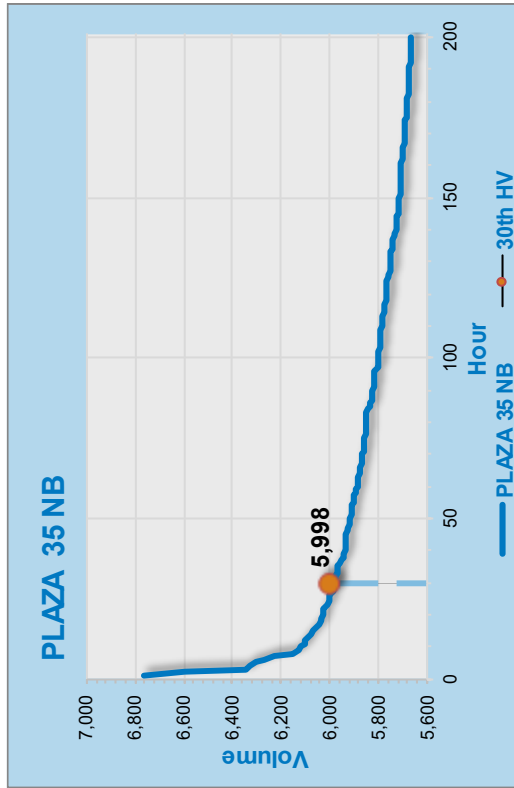

FIGURE 3-G



MAINLINE PLAZA HIGHEST HOURLY VOLUME

FIGURE 3-J

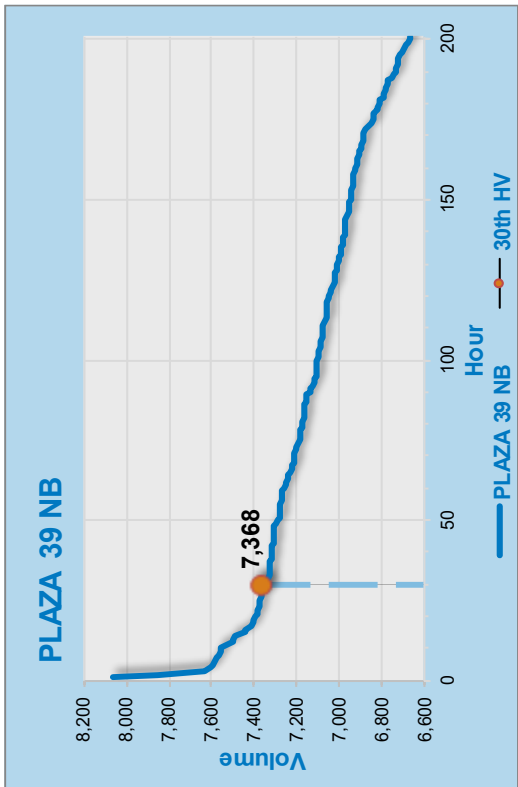

FIGURE 3-L

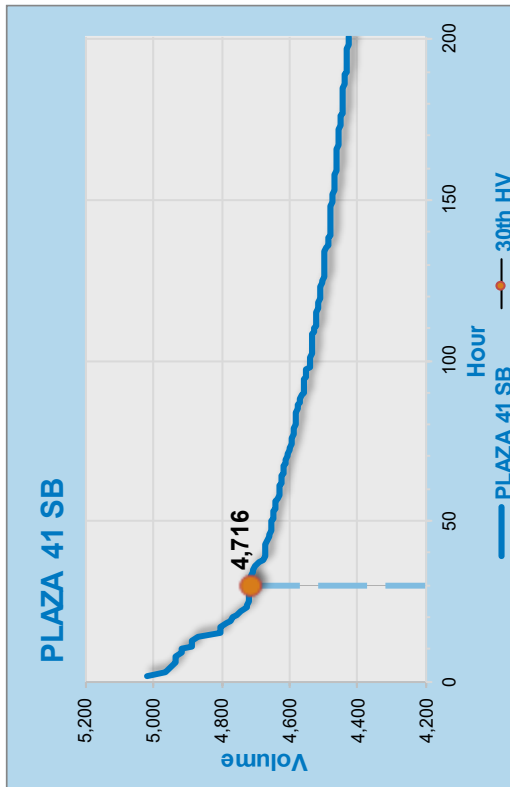

FIGURE 3-I

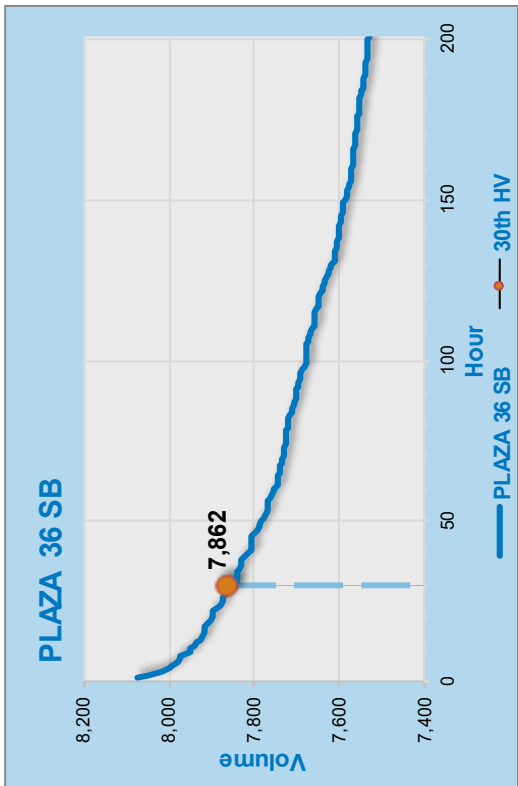
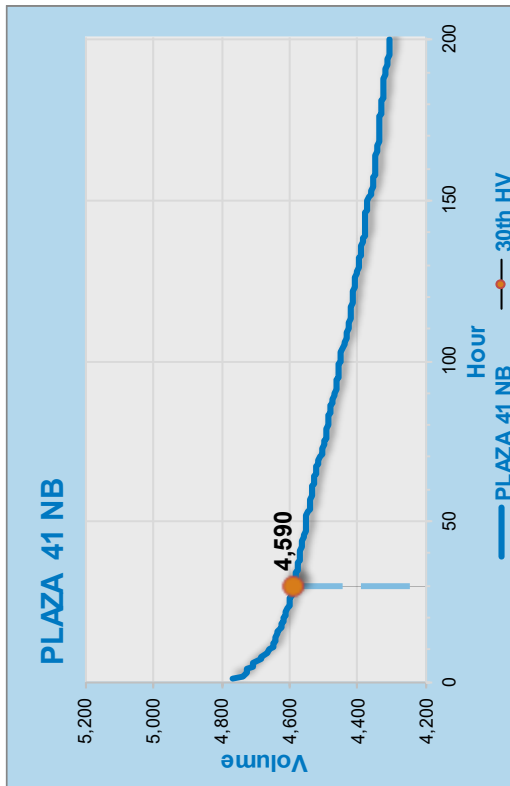

FIGURE 3-K



MAINLINE PLAZA HIGHEST HOURLY VOLUME

FIGURE 3-M

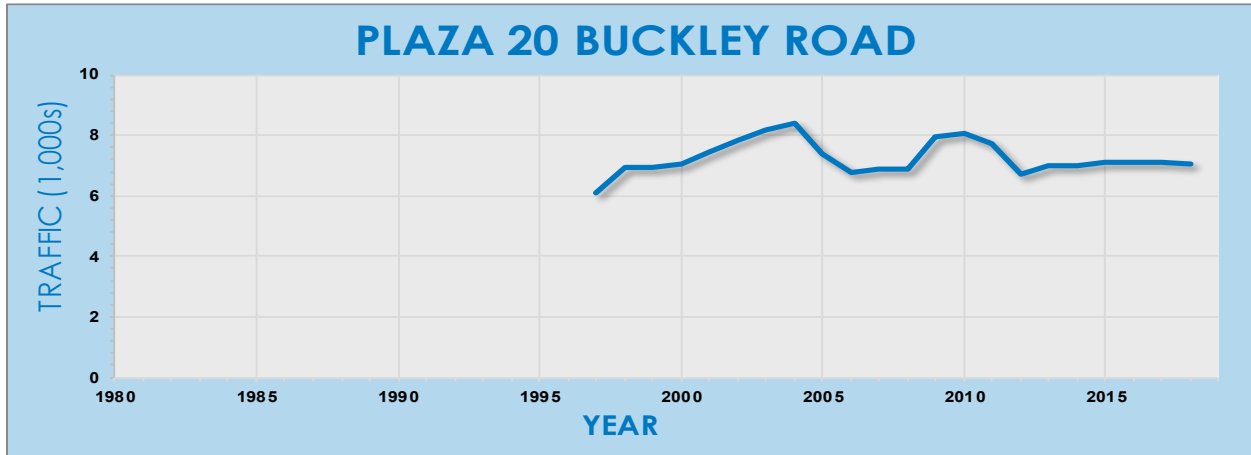

FIGURE 3-N

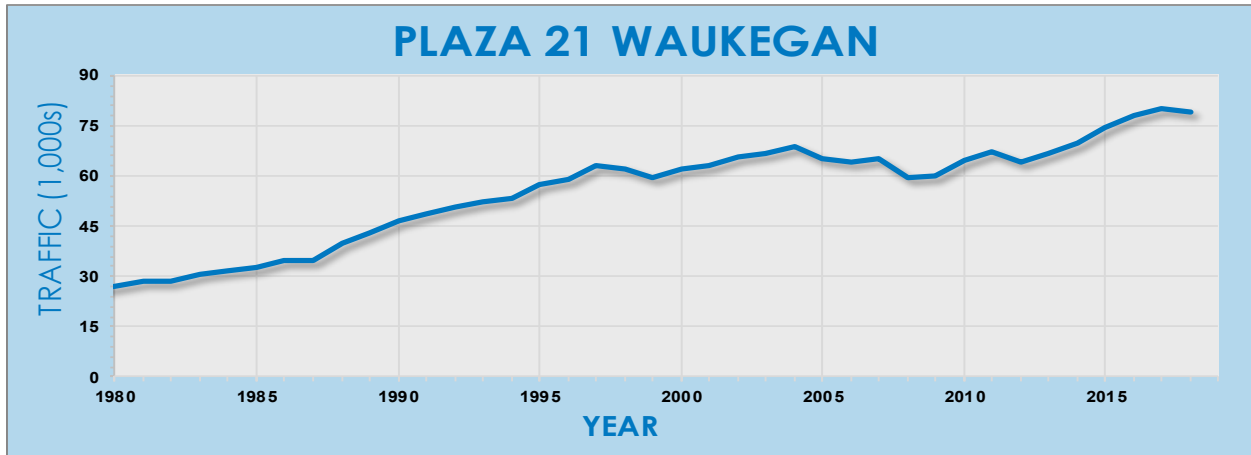
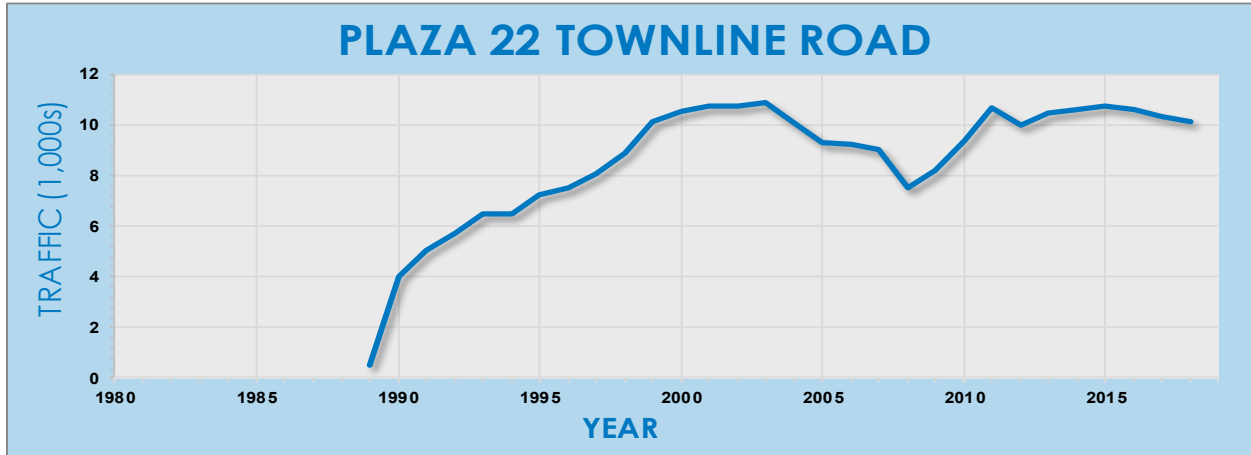

FIGURE 3-O



AVERAGE DAILY TRAFFIC TRENDS

FIGURE 3-P

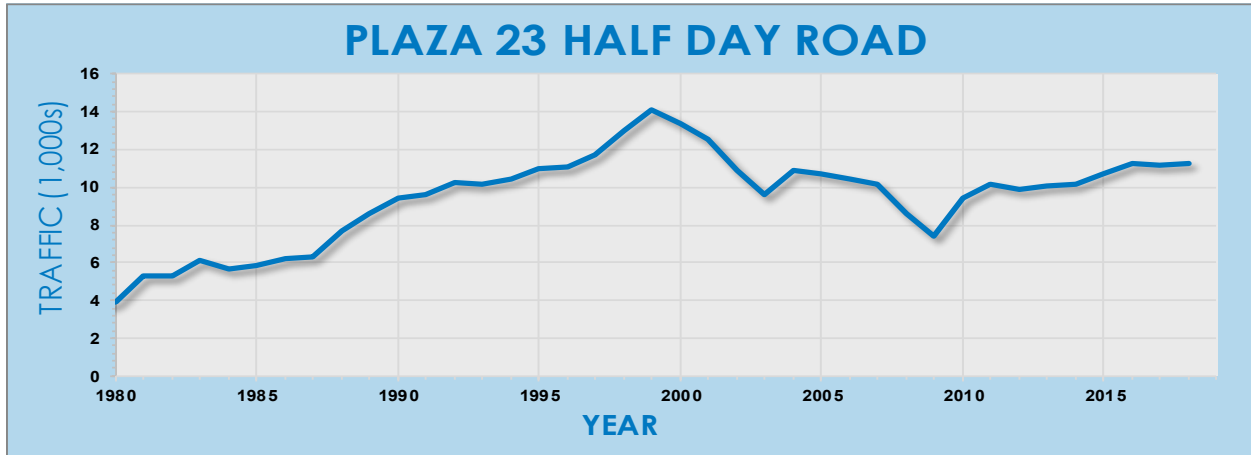

FIGURE 3-Q

Plaza 24 opened in 1999 due to Plaza 25 removal.

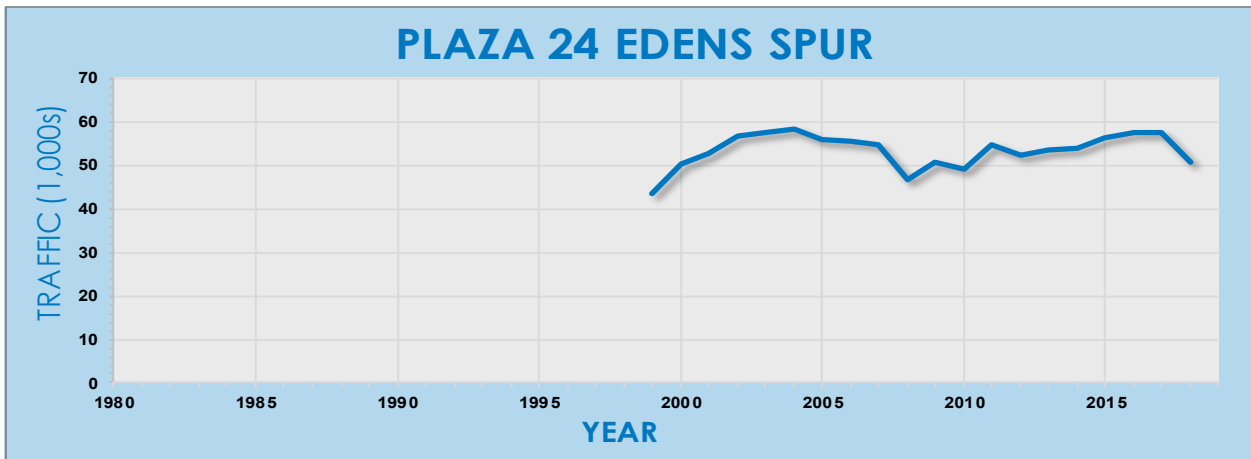
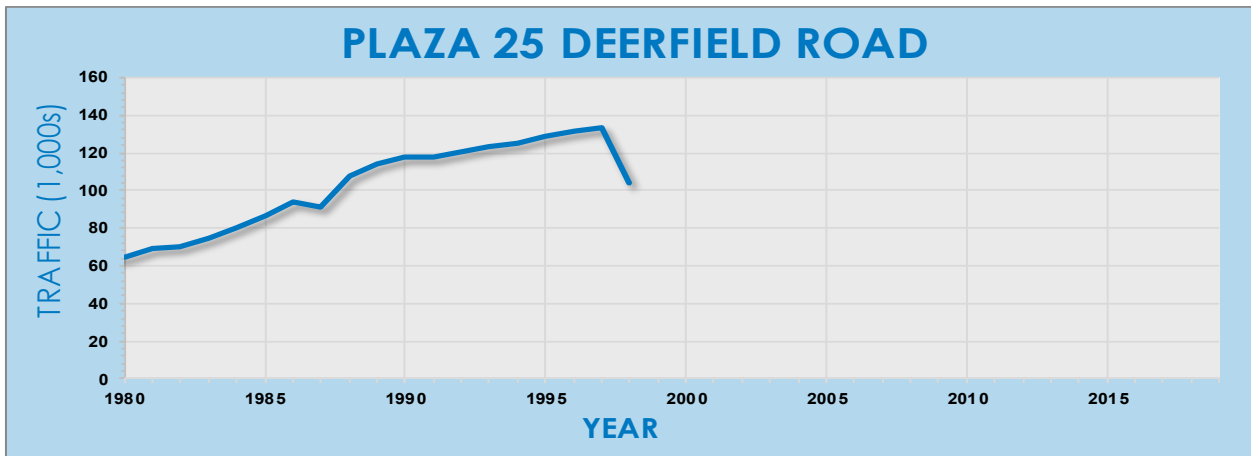

FIGURE 3-R

Plaza 25 removed in 1998.



AVERAGE DAILY TRAFFIC TRENDS

FIGURE 3-S Toll collection at Plaza 26 was moved from ramps to/from the south to ramps to/from the north due to Plaza 25 removal.

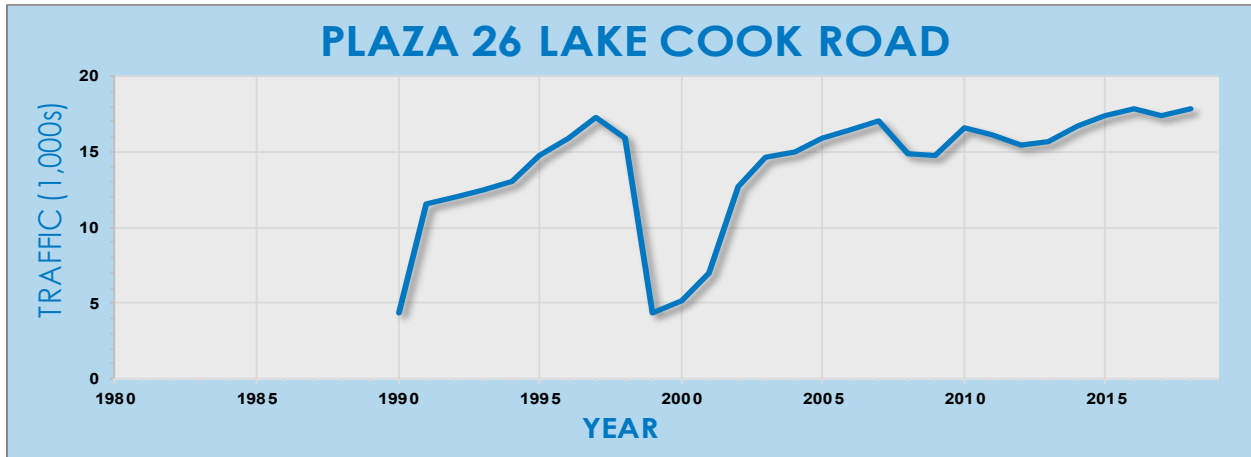

FIGURE 3-T Toll collection at Plaza 27 was moved from ramps to/from the south to ramps to/from the north due to Plaza 25 removal.

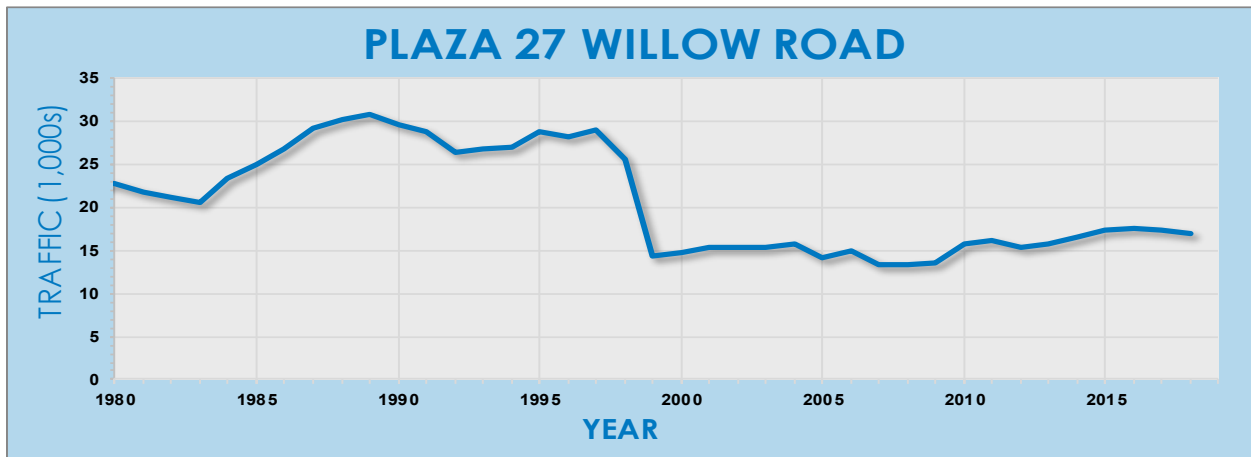

FIGURE 3-U Plaza 28 opened in 1998 due to Plaza 25 removal.



AVERAGE DAILY TRAFFIC TRENDS

FIGURE 3-V

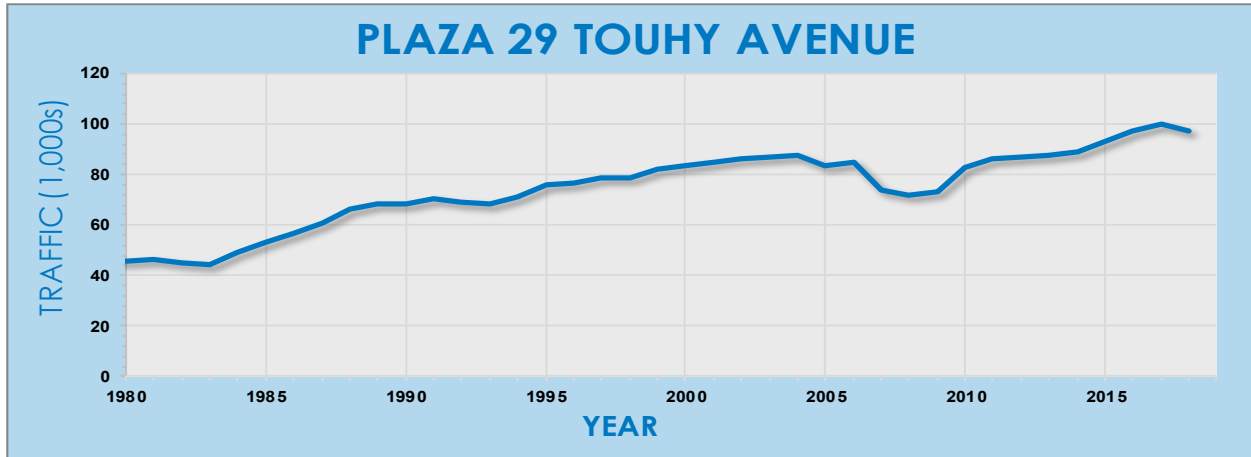

FIGURE 3-W

Plaza 30 opened in 2011.

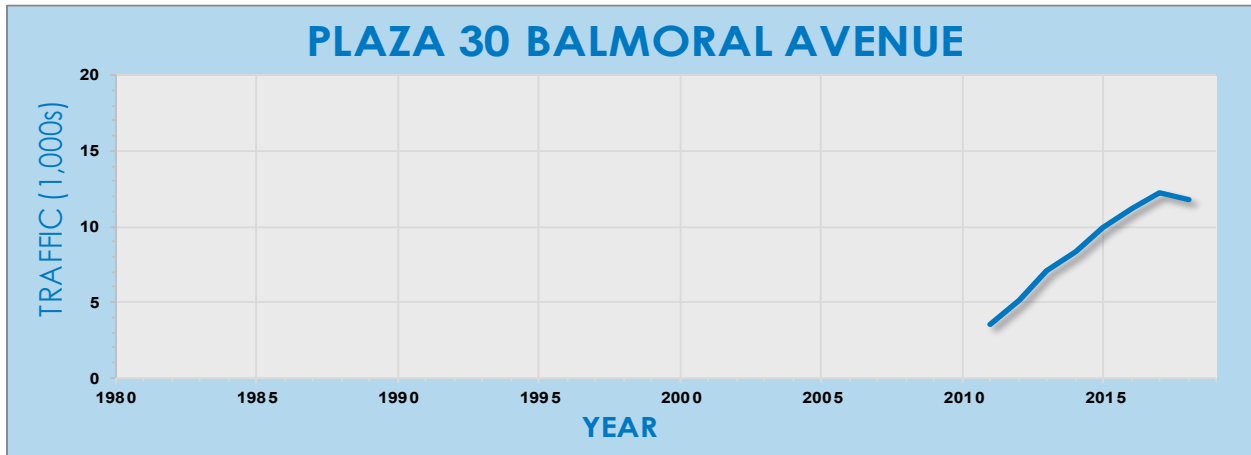
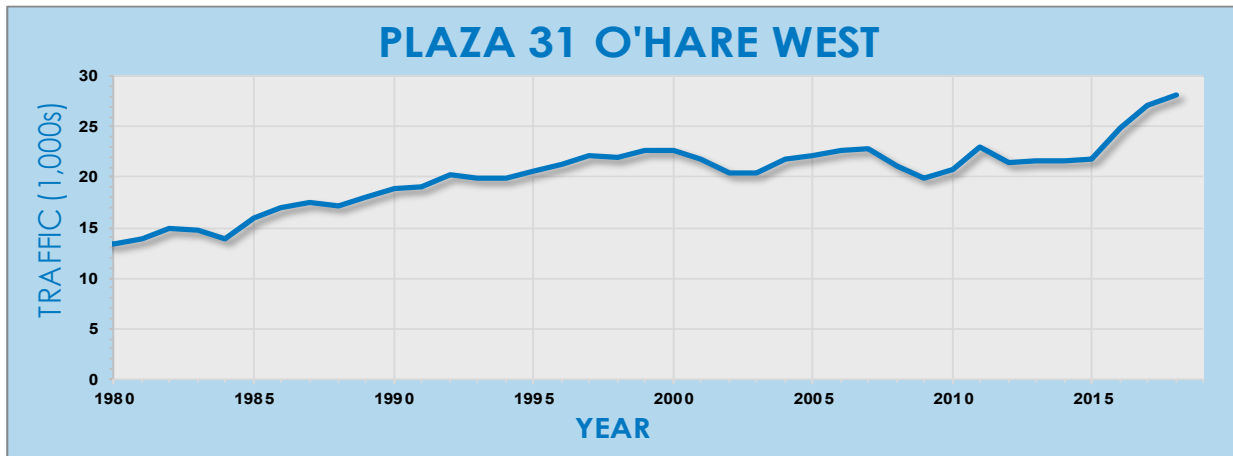

FIGURE 3-X



AVERAGE DAILY TRAFFIC TRENDS

FIGURE 3-Y

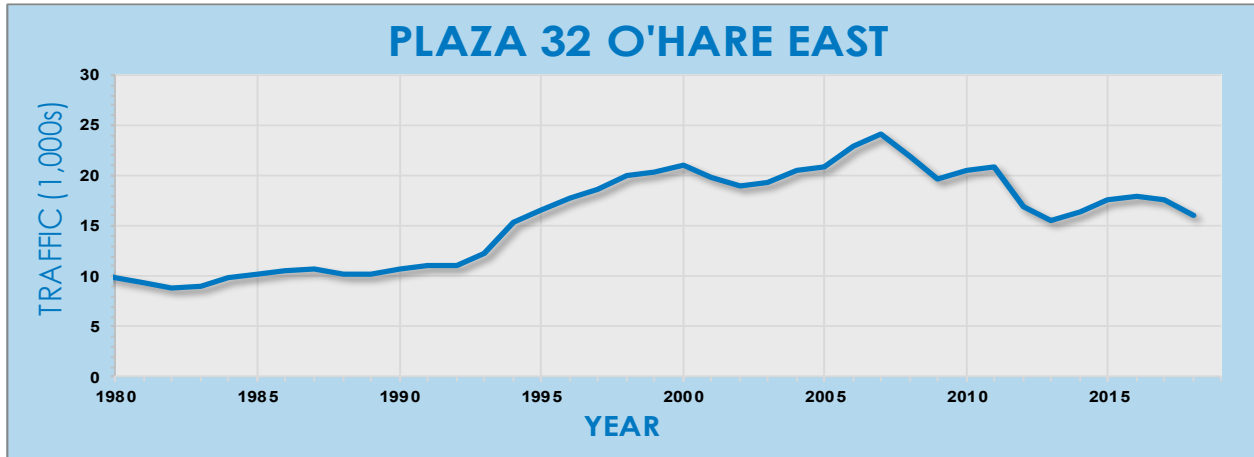

FIGURE 3-Z

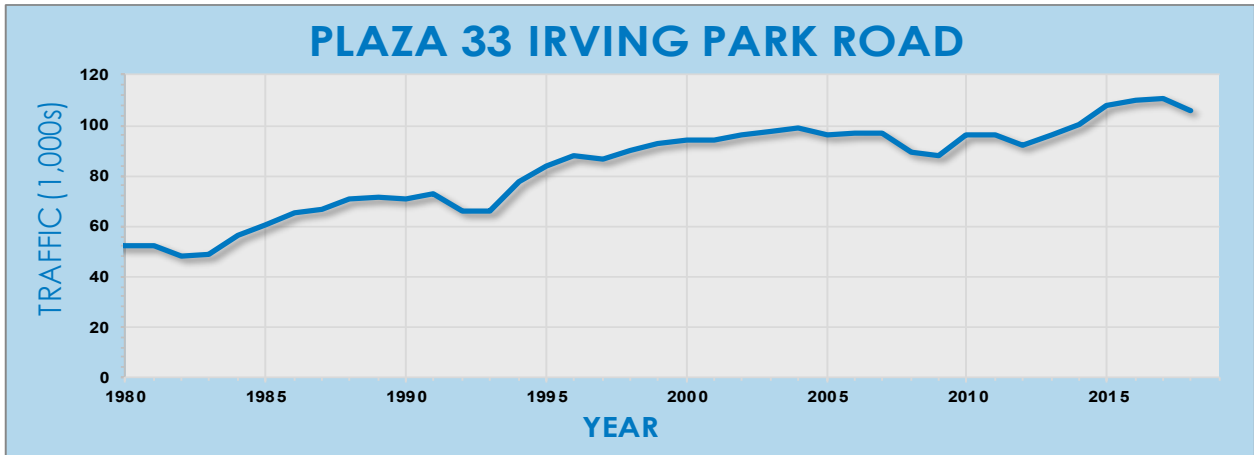
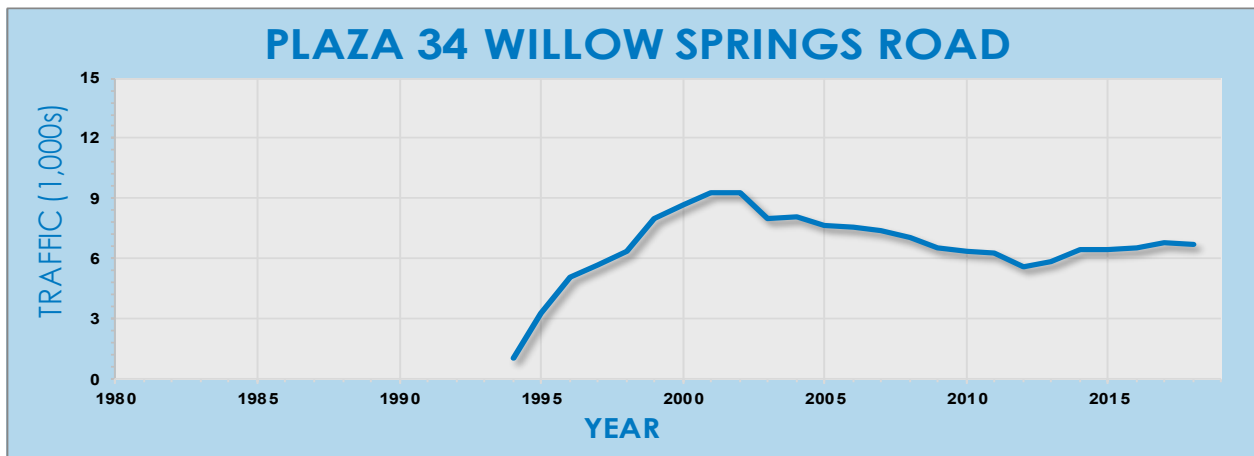

FIGURE 3-AA

Plaza 34 opened in 1994 due to the replacement of southbound Plaza 39 with Plaza 36.



AVERAGE DAILY TRAFFIC TRENDS

FIGURE 3-AB

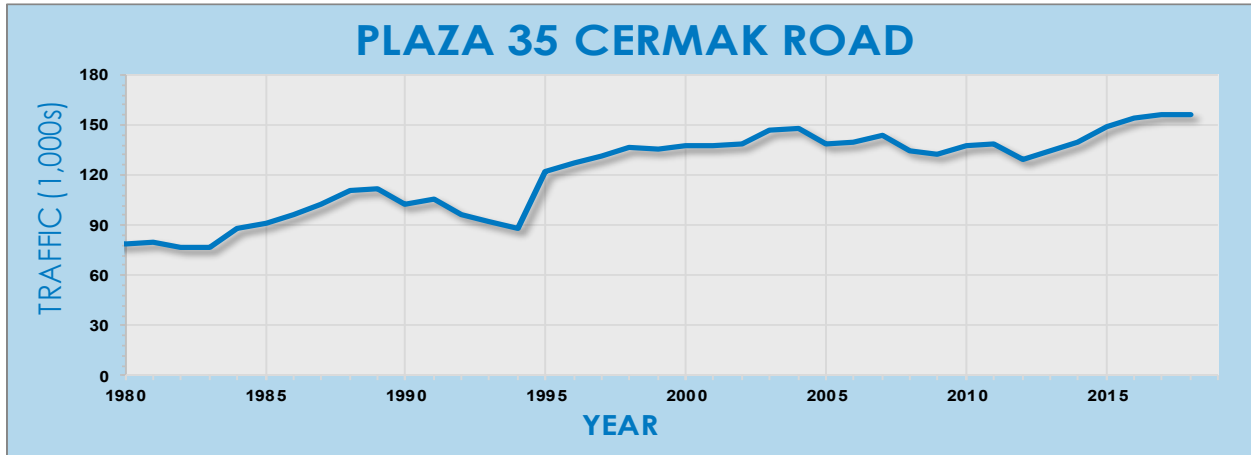

FIGURE 3-AC

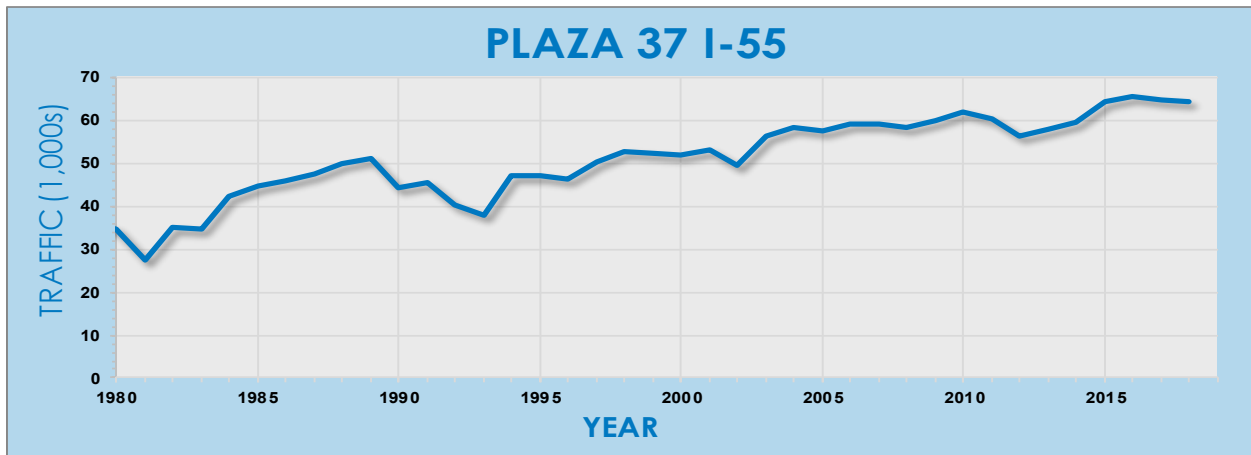
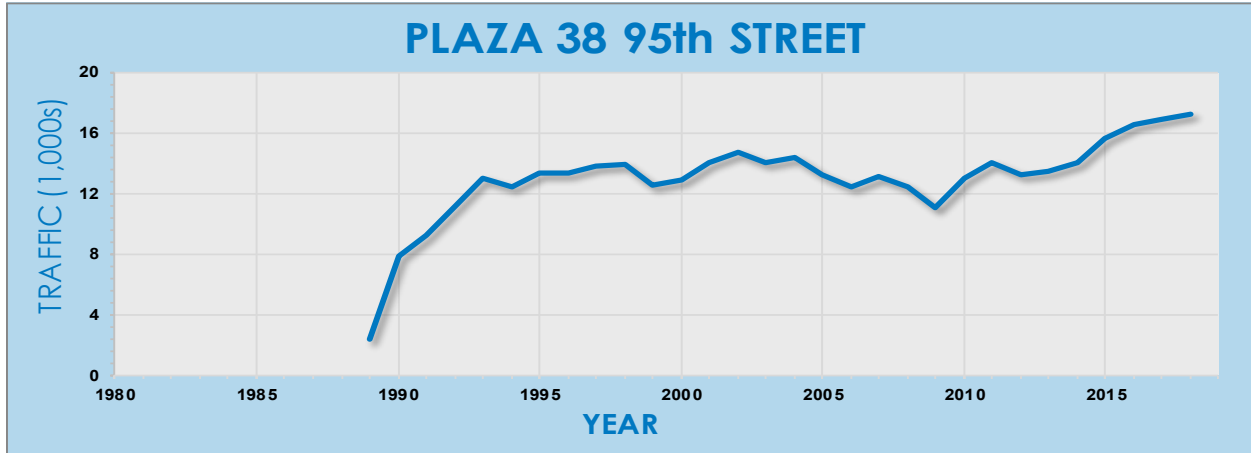

FIGURE 3-AD



AVERAGE DAILY TRAFFIC TRENDS

FIGURE 3-AE

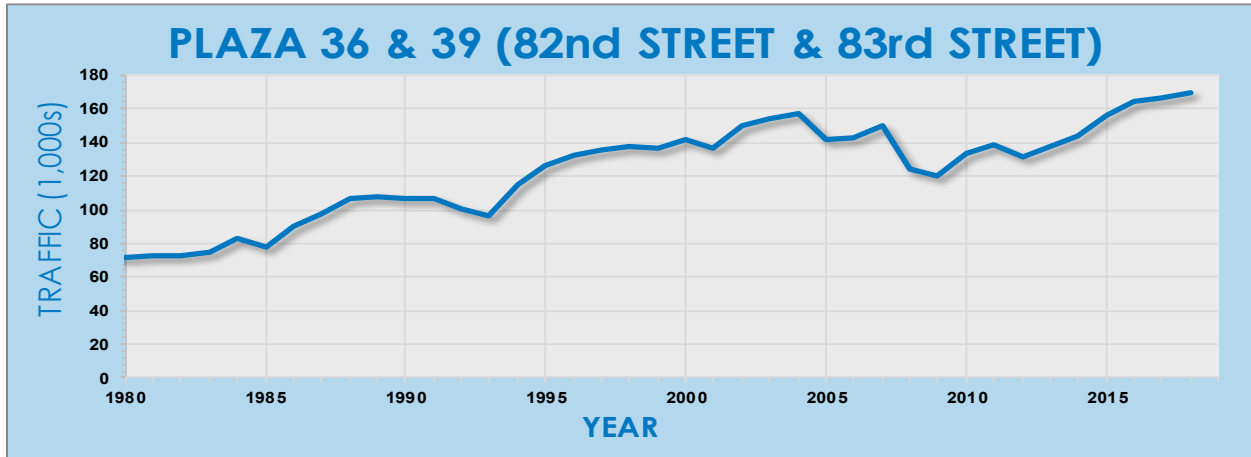

FIGURE 3-AF

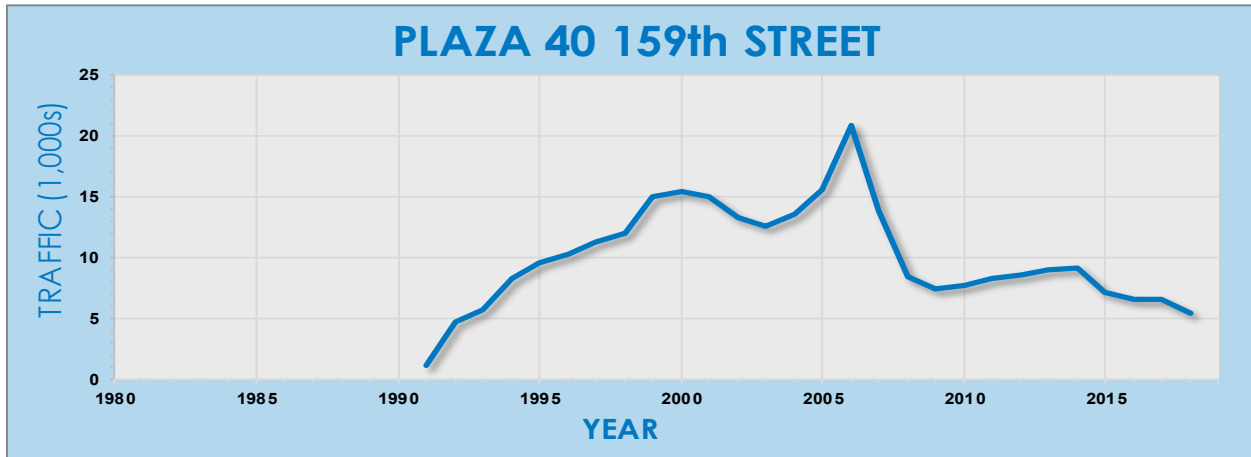
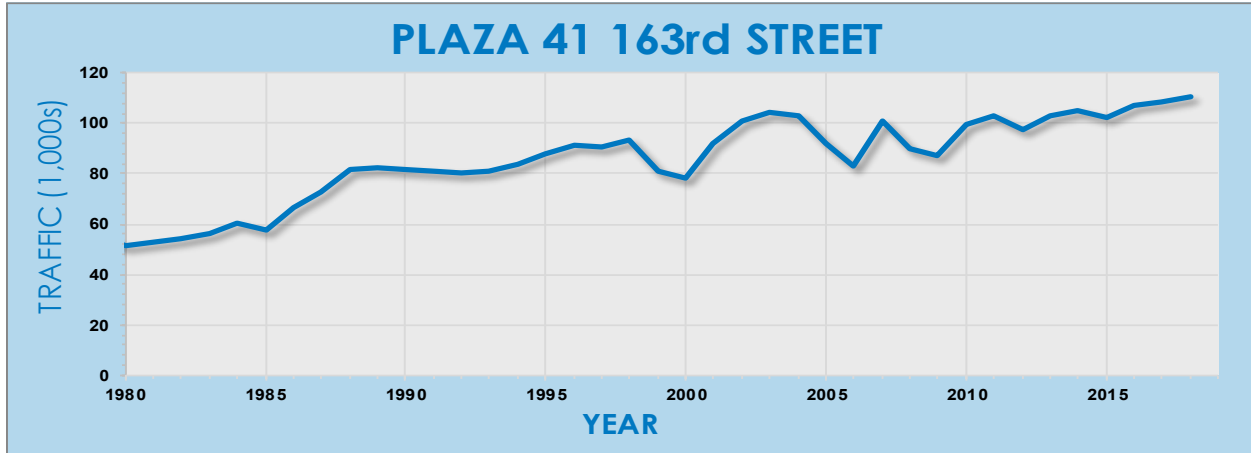

FIGURE 3-AG



AVERAGE DAILY TRAFFIC TRENDS



FIGURE 3-

Plaza 42 opened in 2014.

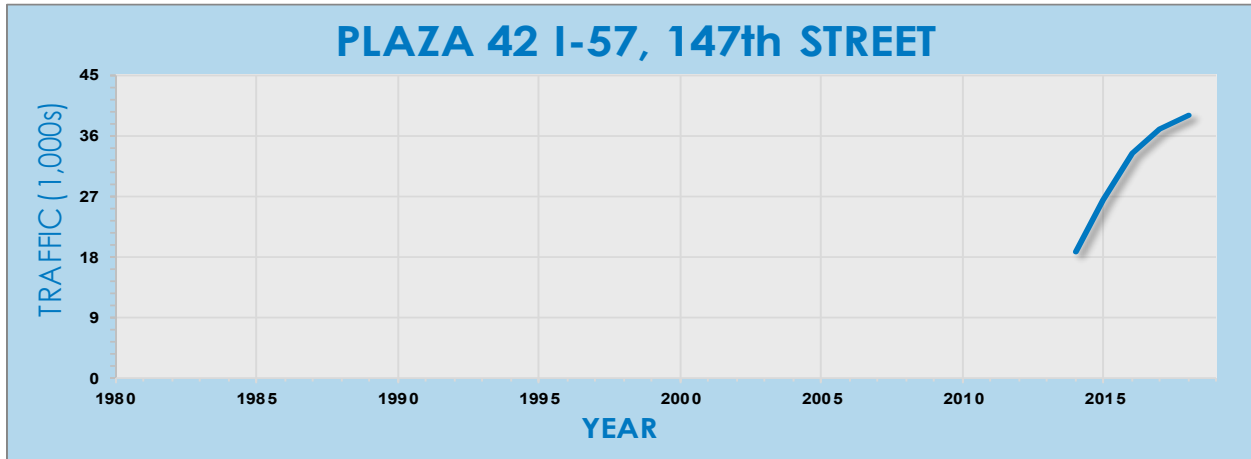

FIGURE 3-AI

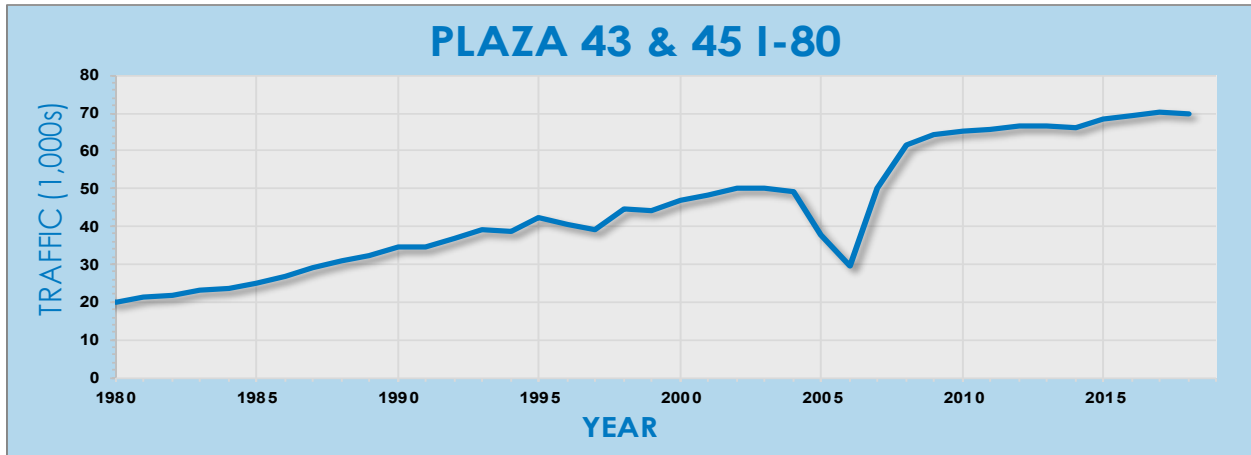
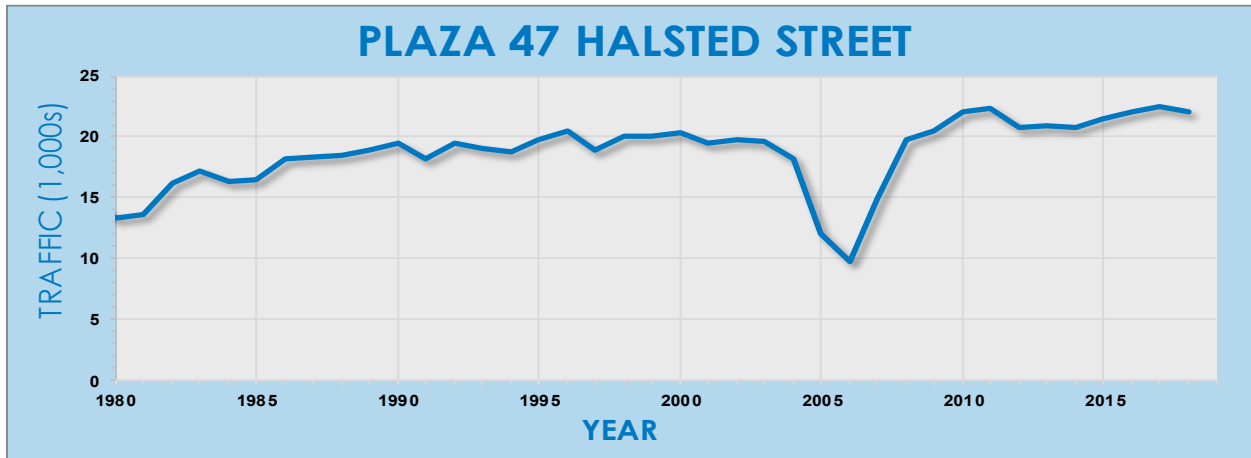

FIGURE 3-AJ



AVERAGE DAILY TRAFFIC TRENDS

AVERAGE WEEKDAY SPEED DISTRIBUTIONS, NORTHERN SECTION

FIGURE 3-AK

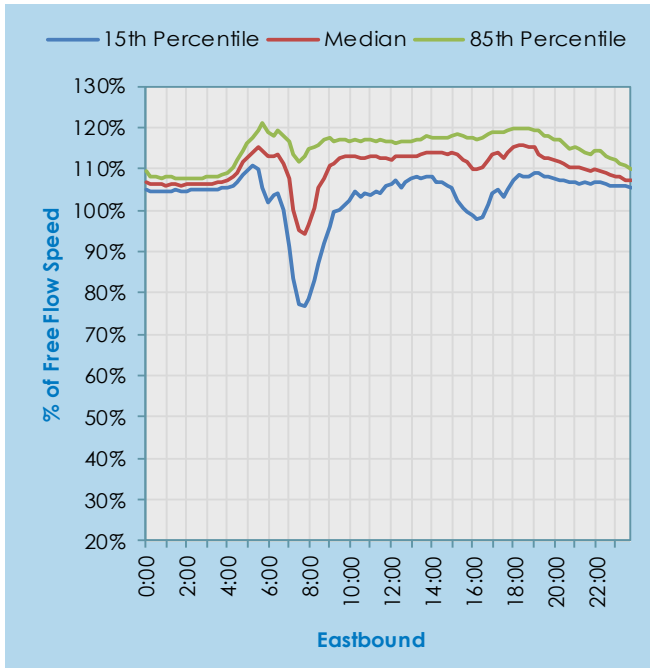
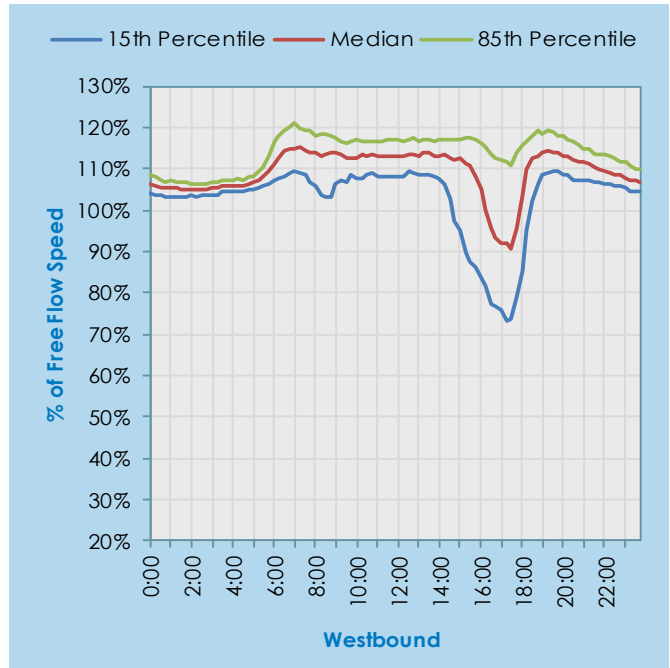

FIGURE 3-AL



AVERAGE WEEKDAY SPEED DISTRIBUTIONS, NORTH CENTRAL SECTION

FIGURE 3-AM

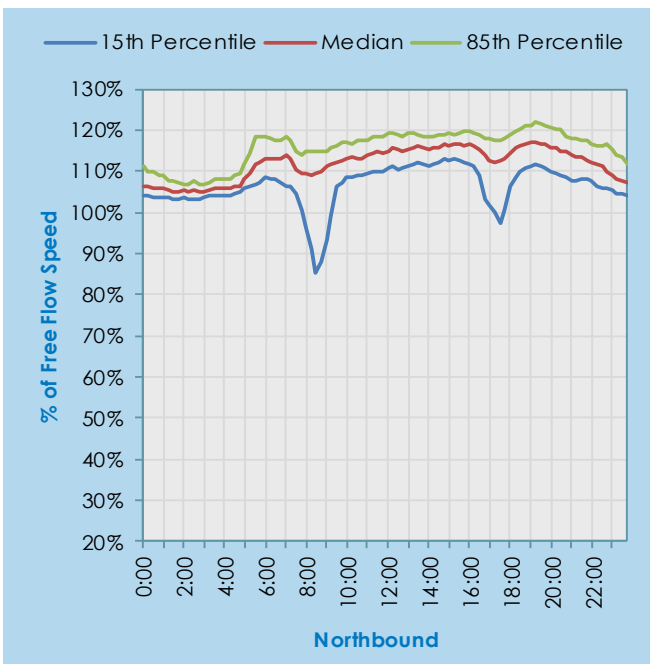
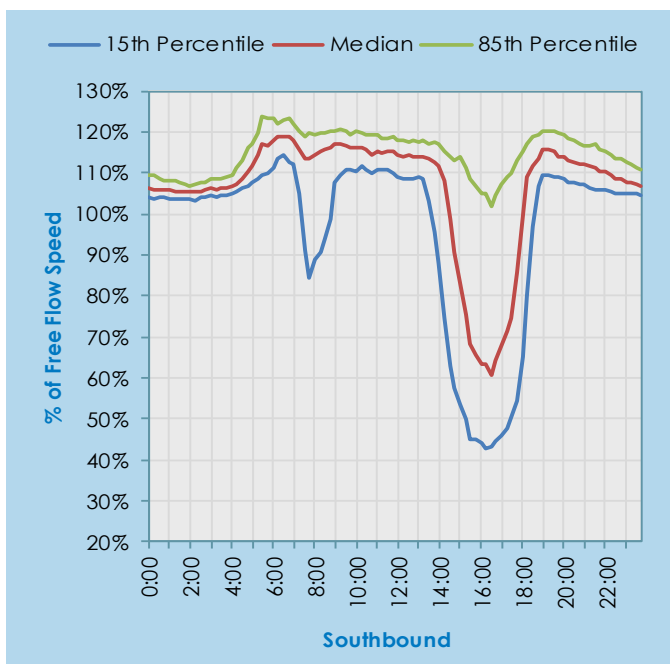

FIGURE 3-AN



AVERAGE WEEKDAY SPEED DISTRIBUTIONS, SOUTH CENTRAL SECTION

FIGURE 3-AO

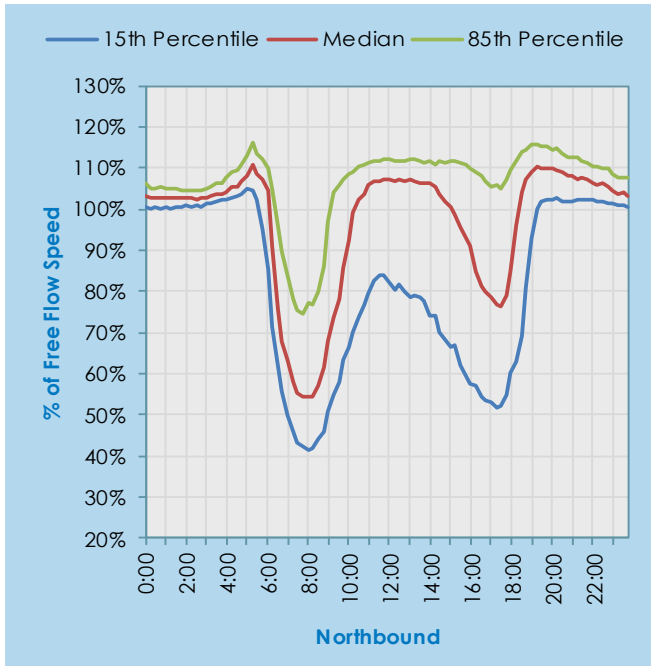
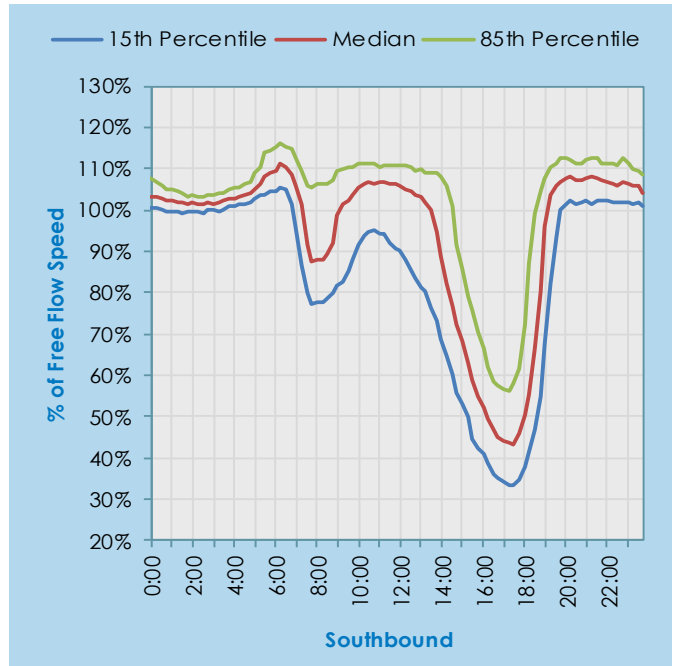

FIGURE 3-AP



AVERAGE WEEKDAY SPEED DISTRIBUTIONS, SOUTHERN SECTION

FIGURE 3-AQ

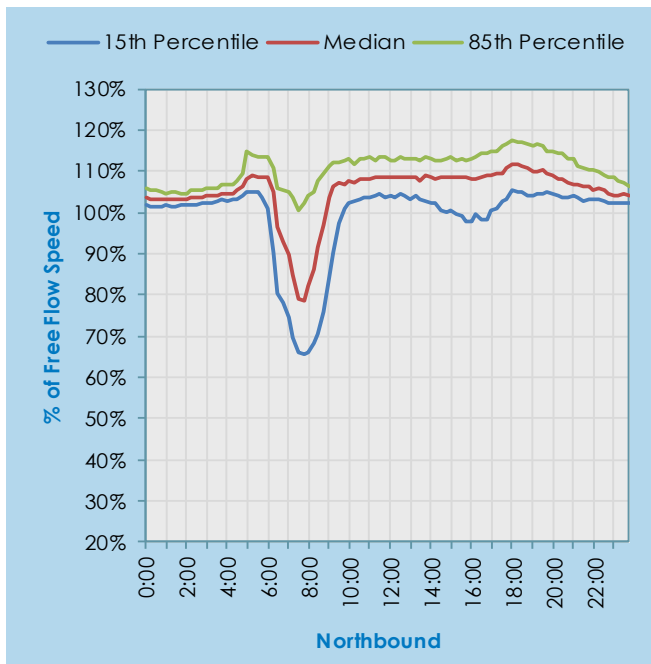
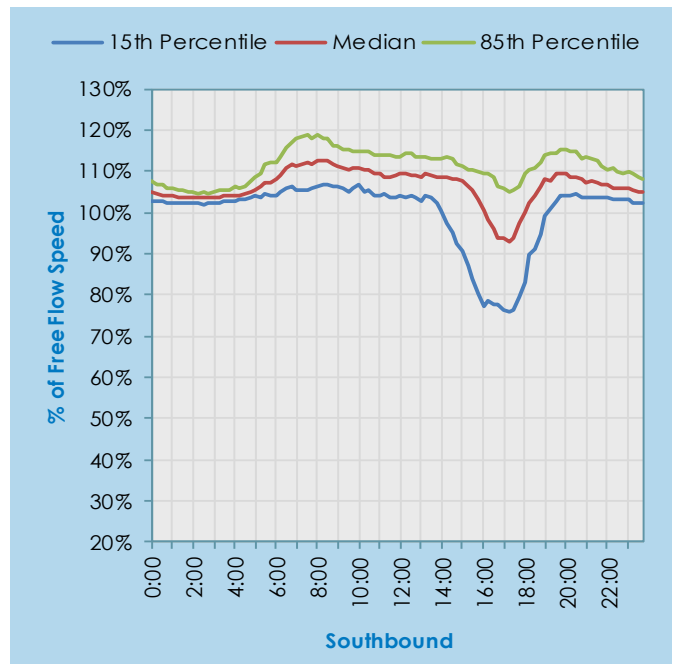
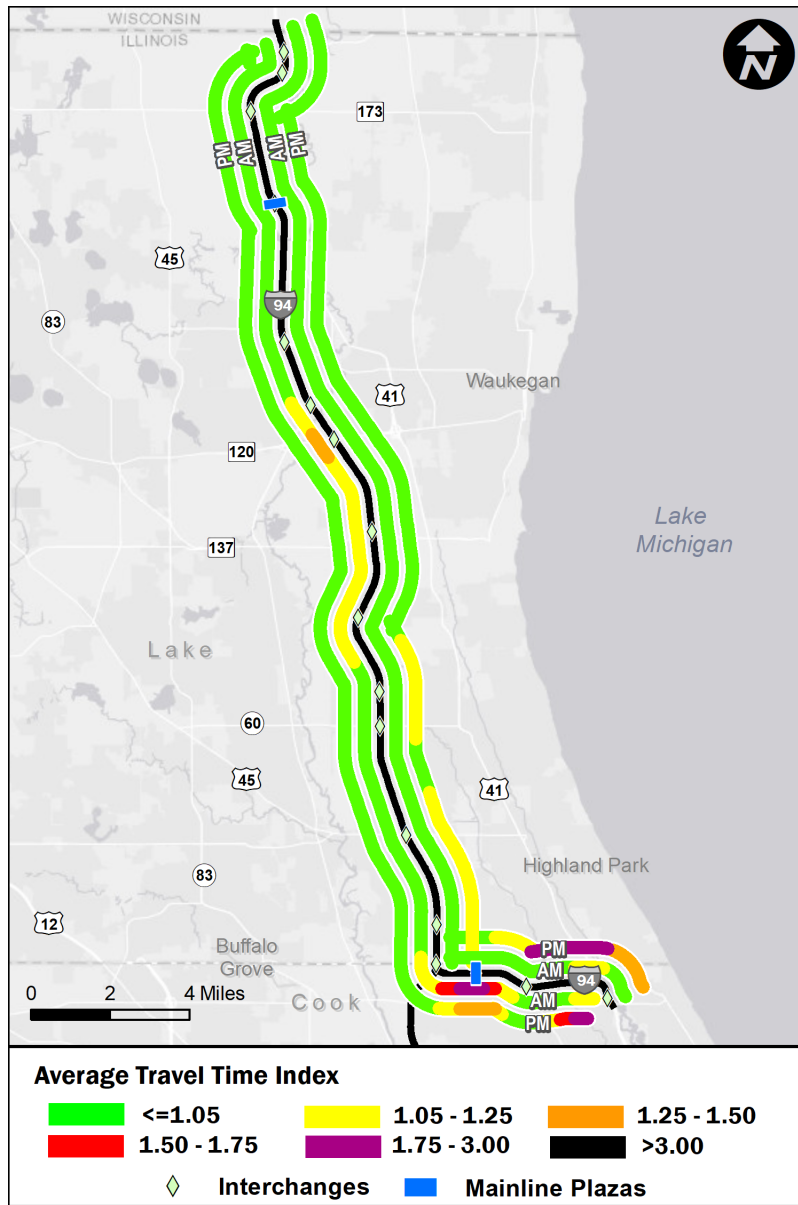

FIGURE 3-AR





Quarter	Range	Average Speed (mph)		Average Travel Time Index		Planning Time Index		Total Delay (veh-hrs / 1000 VMT)		Average Daily Delay (veh-hrs)		Percent Congested Travel	
		AM	PM	AM	PM	AM	PM	AM	PM	AM	PM	AM	PM
1	January-March	65	66	0.93	0.91	1.19	1.03	0.7	0.9	399	540	9	11
2	April-June	66	61	0.90	0.98	0.99	1.15	0.4	1.8	240	1,187	6	17
3	July-September	67	64	0.89	0.93	0.97	1.08	0.4	0.9	287	481	8	11
4	October-December	63	63	0.95	0.95	1.07	1.10	1.2	1.0	789	631	15	13
Total	2018 Entire Year	65	64	0.92	0.94	1.06	1.09	0.7	1.1	429	710	9	13

Data source: INRIX. Roadway performance measures sections and terms are defined on pages 1-4 and 1-5.

FIGURE 3-AS: ROADWAY PERFORMANCE MEASURES—NORTHERN SECTION

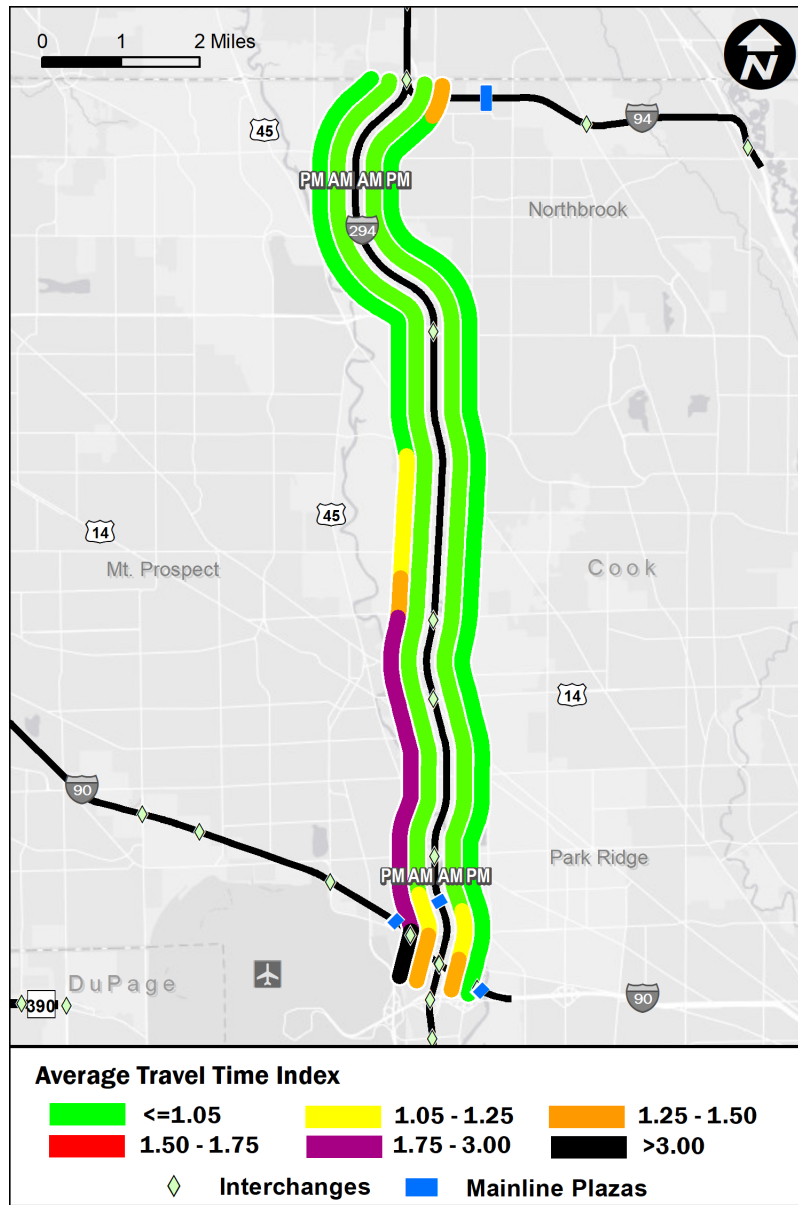

Quarter	Range	Average Speed (mph)		Average Travel Time Index		Planning Time Index		Total Delay (veh-hrs / 1000 VMT)		Average Daily Delay (veh-hrs)		Percent Congested Travel	
		AM	PM	AM	PM	AM	PM	AM	PM	AM	PM	AM	PM
1	January-March	65	65	0.93	0.92	1.18	1.03	0.5	0.9	185	320	10	10
2	April-June	59	50	1.02	1.21	1.34	1.51	2.0	5.4	712	1,887	13	20
3	July-September	65	64	0.93	0.94	1.00	1.05	0.8	0.8	321	289	10	12
4	October-December	48	55	1.24	1.10	1.61	1.31	5.7	3.2	2,140	1,089	24	18
Total	2018 Entire Year	59	58	1.03	1.04	1.28	1.22	2.3	2.6	840	896	14	15

Data source: INRIX. Roadway performance measures sections and terms are defined on pages 1-4 and 1-5.

FIGURE 3-AT: ROADWAY PERFORMANCE MEASURES—NORTH CENTRAL SECTION

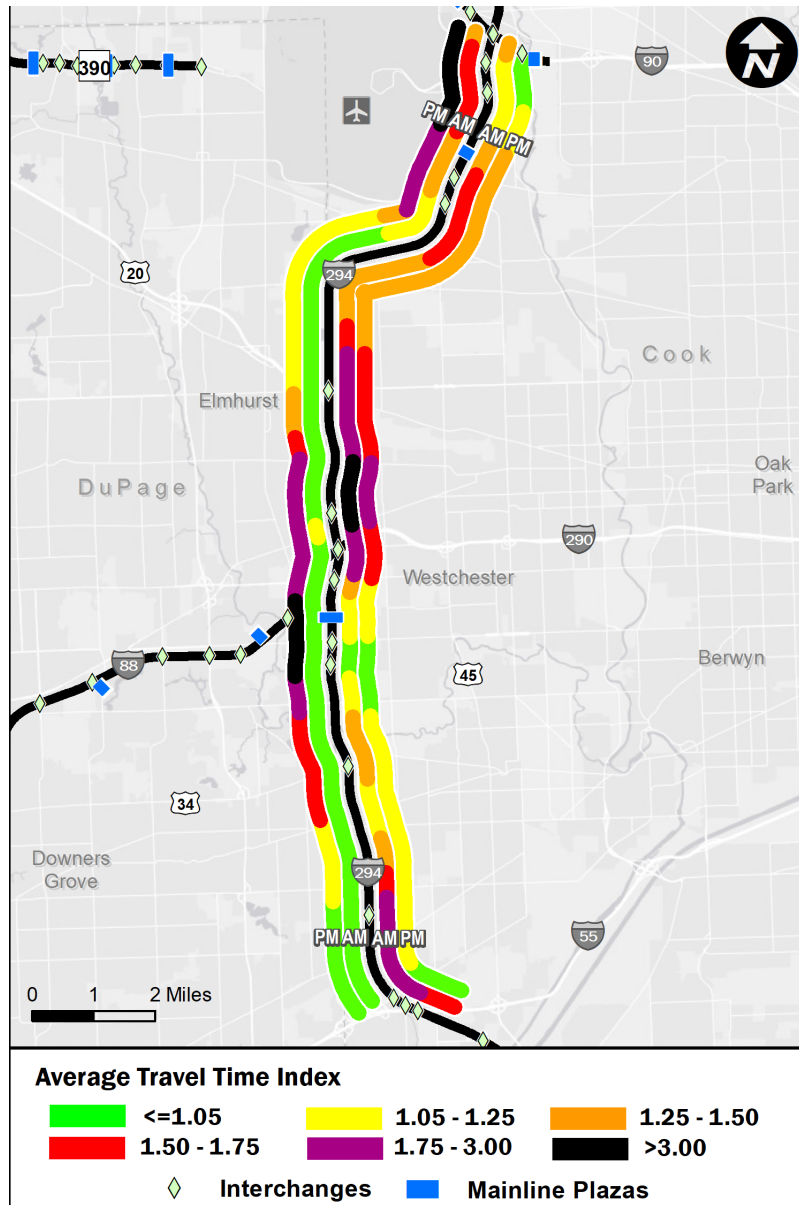

Quarter	Range	Average Speed (mph)		Average Travel Time Index		Planning Time Index		Total Delay (veh-hrs / 1000 VMT)		Average Daily Delay (veh-hrs)		Percent Congested Travel	
		AM	PM	AM	PM	AM	PM	AM	PM	AM	PM	AM	PM
1	January-March	50	43	1.21	1.40	1.69	1.79	4.1	7.4	2,400	4,401	45	53
2	April-June	44	34	1.38	1.79	1.91	2.44	6.9	13.5	3,921	7,459	48	73
3	July-September	45	46	1.33	1.29	1.61	1.59	6.3	5.5	3,924	3,075	50	50
4	October-December	36	39	1.65	1.55	2.27	2.09	11.3	9.6	6,665	5,226	62	66
Total	2018 Entire Year	44	40	1.39	1.51	1.87	1.97	7.1	9.0	4,227	5,040	51	60

Data source: INRIX. Roadway performance measures sections and terms are defined on pages 1-4 and 1-5.

FIGURE 3-AU: ROADWAY PERFORMANCE MEASURES—SOUTH CENTRAL SECTION

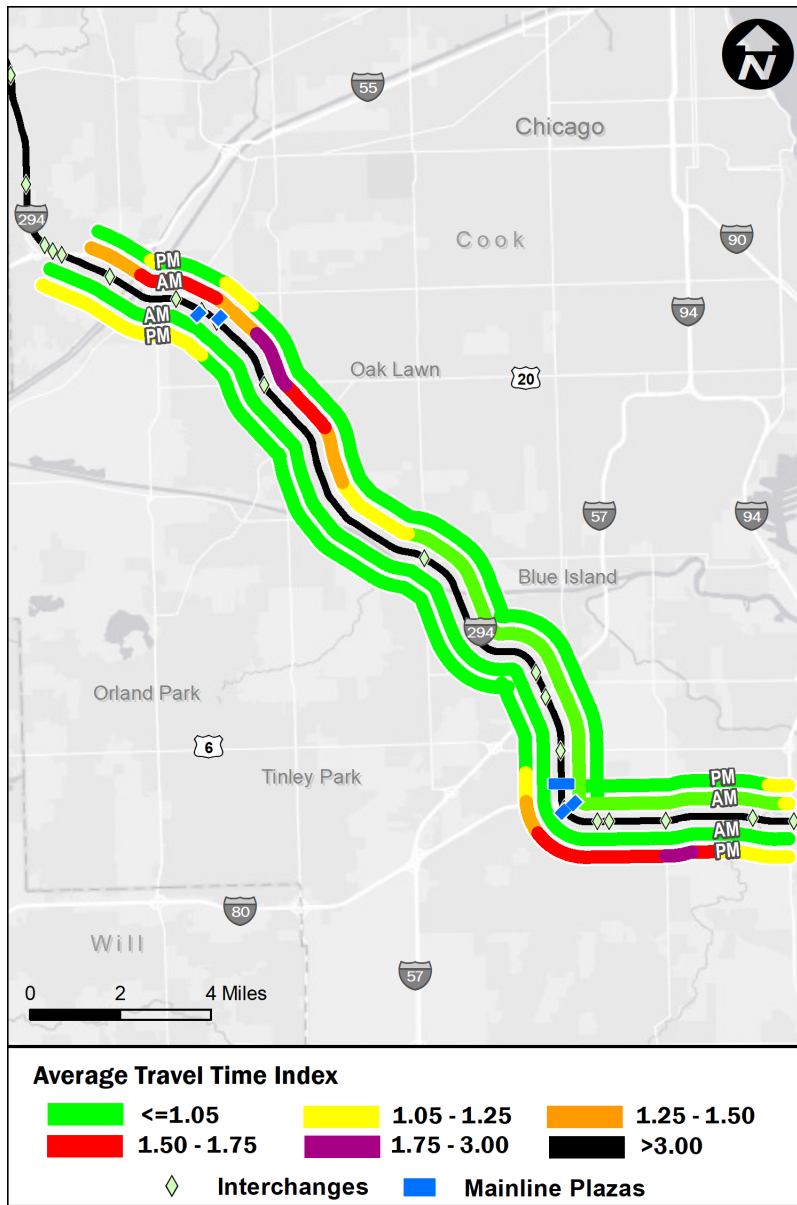

Quarter	Range	Average Speed (mph)		Average Travel Time Index		Planning Time Index		Total Delay (veh-hrs / 1000 VMT)		Average Daily Delay (veh-hrs)		Percent Congested Travel	
		AM	PM	AM	PM	AM	PM	AM	PM	AM	PM	AM	PM
1	January-March	56	59	1.06	1.01	1.33	1.16	2.1	1.8	1,254	1,165	24	19
2	April-June	61	60	0.99	1.00	1.11	1.20	0.9	1.6	598	1,117	12	19
3	July-September	57	57	1.05	1.05	1.18	1.15	2.2	1.9	1,447	1,152	24	22
4	October-December	59	60	1.02	1.00	1.25	1.16	1.8	0.9	1,281	613	16	17
Total	2018 Entire Year	58	59	1.03	1.02	1.22	1.17	1.8	1.6	1,145	1,012	19	19

Data source: INRIX. Roadway performance measures sections and terms are defined on pages 1-4 and 1-5.

FIGURE 3-AV: ROADWAY PERFORMANCE MEASURES, SOUTHERN SECTION

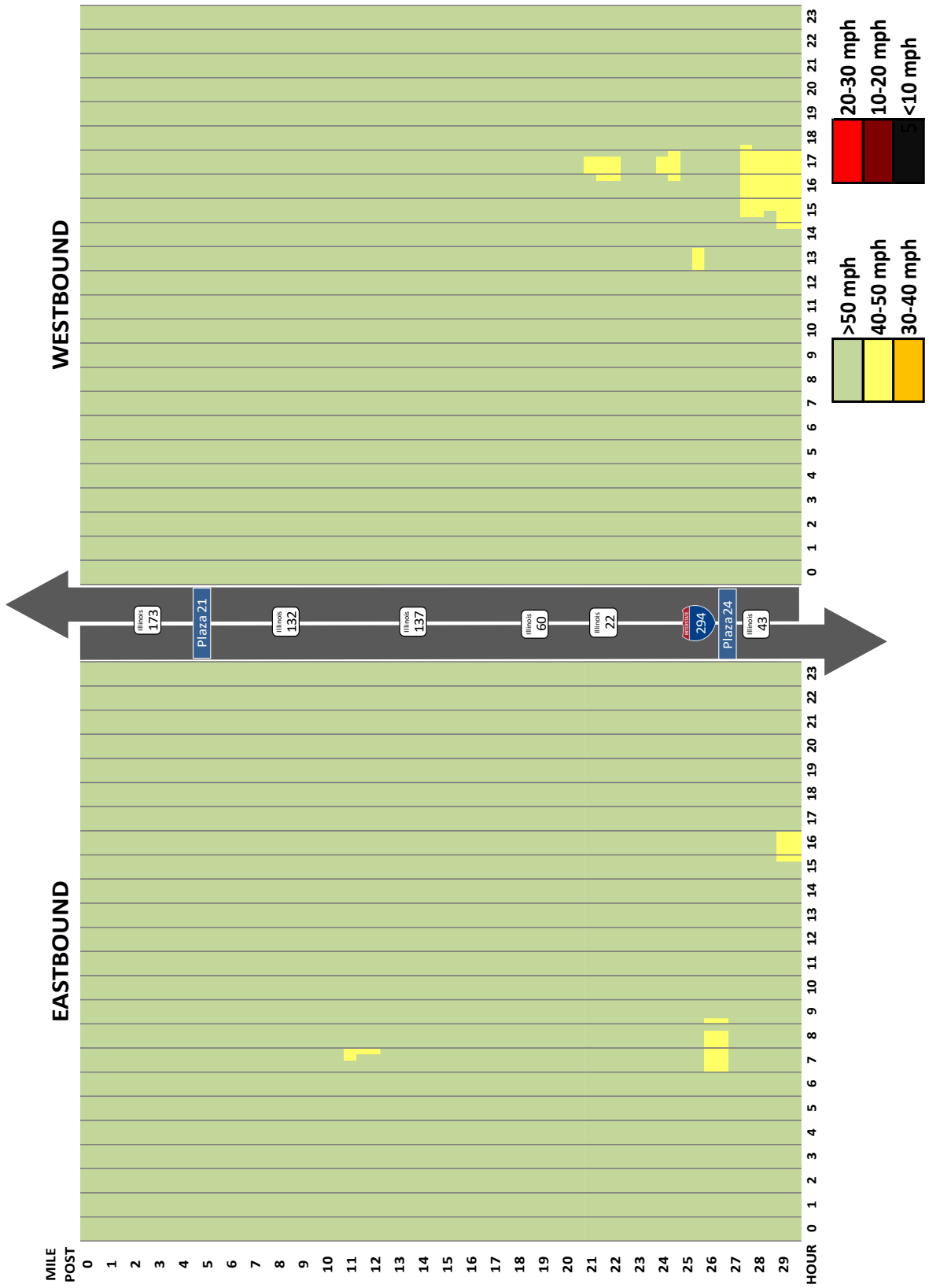

FIGURE 3-AW: AVERAGE SPEED CONTOURS I-94 MP 0.0 to 29.5

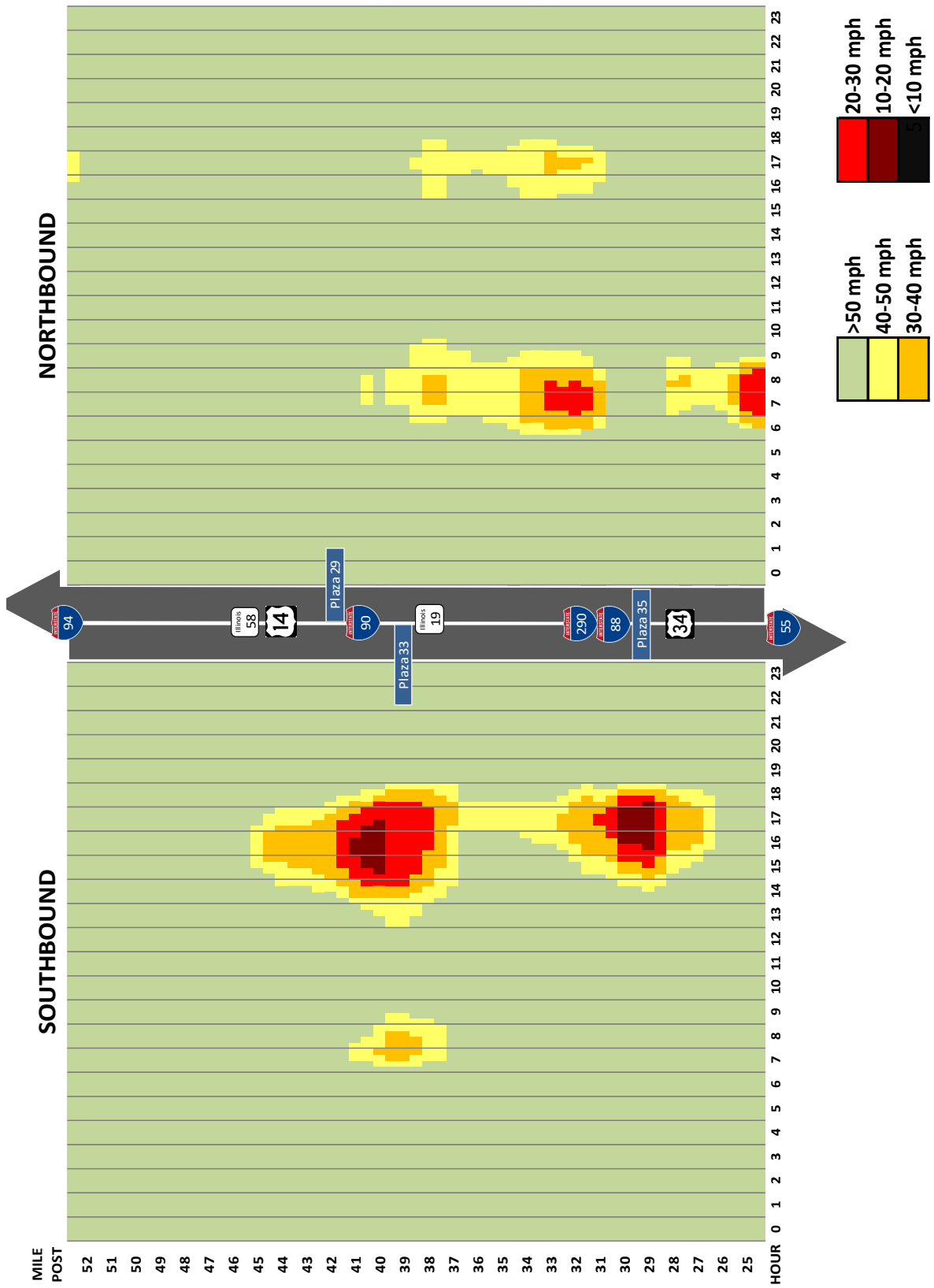

FIGURE 3-AX: AVERAGE SPEED CONTOURS, I-294 MP 24.5 TO 52.5

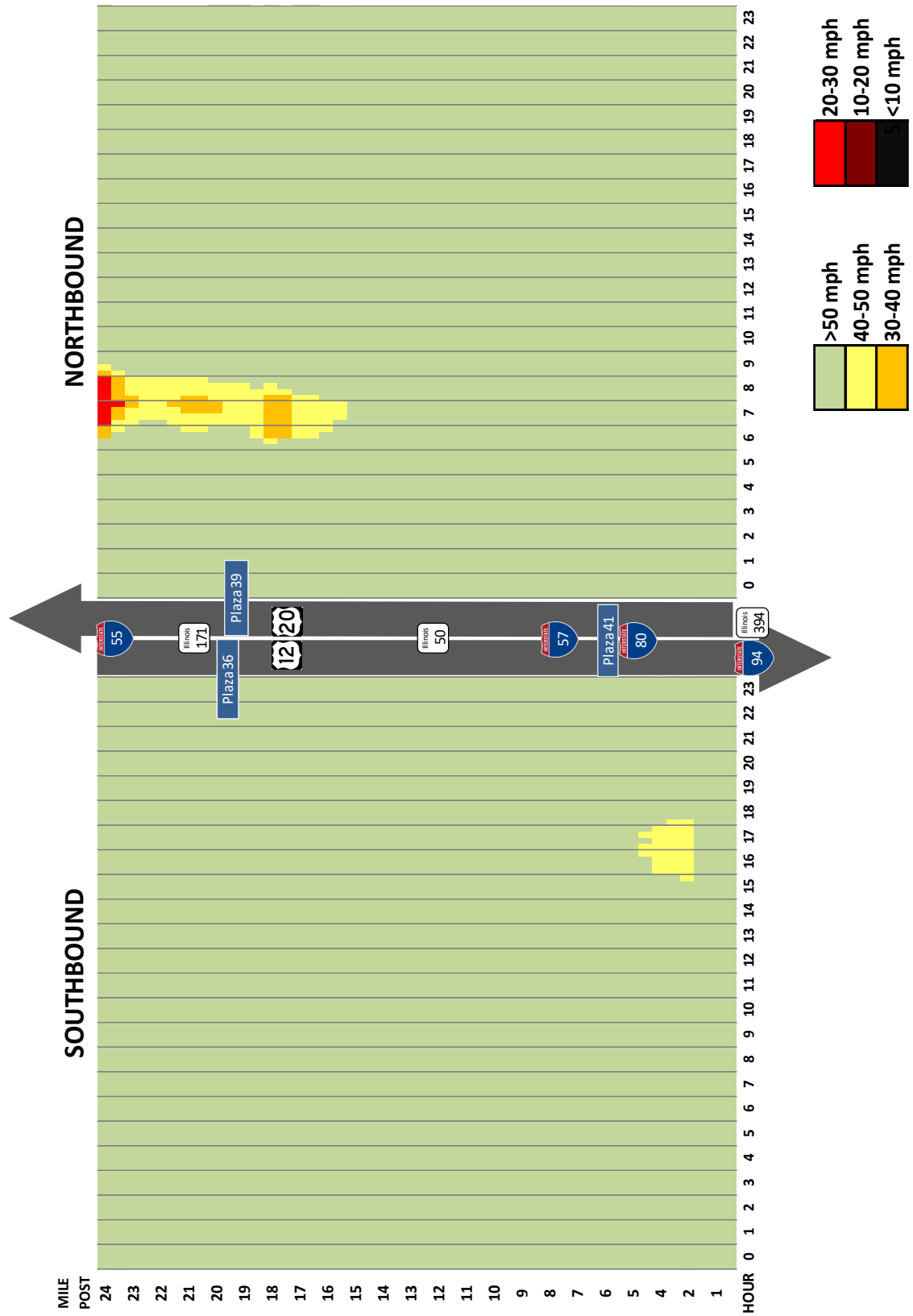
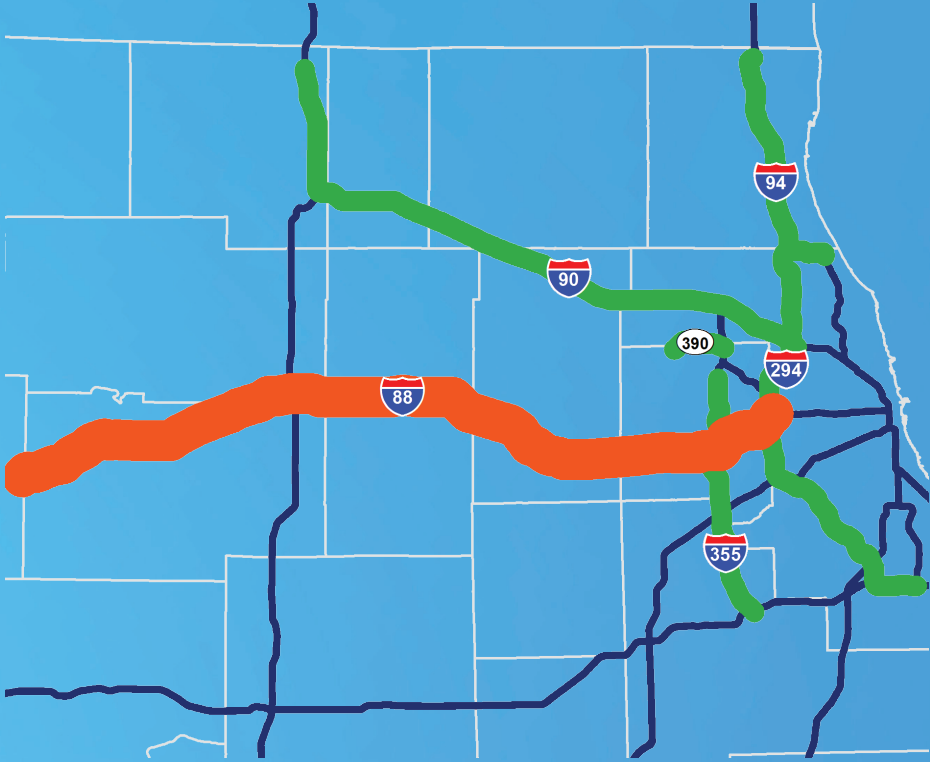

FIGURE 3-AY: AVERAGE SPEED CONTOURS, I-294 MP 0.0 TO 24.0

Reagan Memorial Tollway



Reagan Memorial
Tollway



SECTION 4 Reagan Memorial Tollway

TABULATIONS TABLE

	PAGE
4-A Average Daily Traffic Volumes Between Interchanges 1980 – 2018 (Westbound)	4-4
4-B Average Daily Traffic Volumes Between Interchanges 1980 – 2018 (Eastbound)	4-5
4-C General Statistics for Mainline Plazas	4-6
4-D Indexed Monthly Variation by Mainline Plaza	4-8
4-E Indexed Daily Variation by Mainline Plaza	4-8
4-F Annual Total Transactions by Toll Plaza	4-9
4-G Average Daily Traffic Data	4-10

ILLUSTRATIONS FIGURE

	PAGE
4-A Mainline Plaza Highest Hourly Volume Plaza 51 WB	4-11
4-B Mainline Plaza Highest Hourly Volume Plaza 52 EB	4-11
4-C Mainline Plaza Highest Hourly Volume Plaza 61 EB	4-11
4-D Mainline Plaza Highest Hourly Volume Plaza 61 WB	4-11
4-E Mainline Plaza Highest Hourly Volume Plaza 66 EB	4-12
4-F Mainline Plaza Highest Hourly Volume Plaza 66 WB	4-12
4-G Mainline Plaza Highest Hourly Volume Plaza 69 EB	4-12
4-H Mainline Plaza Highest Hourly Volume Plaza 69 WB	4-12
4-I Average Daily Traffic Trends Plaza 51 York Road	4-13
4-J Average Daily Traffic Trends Plaza 52 Meyers Road	4-13
4-K Average Daily Traffic Trends Plaza 53 Spring Road	4-13
4-L Average Daily Traffic Trends Plaza 54 Illinois Route 83	4-14
4-M Average Daily Traffic Trends Plaza 55 Midwest Road	4-14
4-N Average Daily Traffic Trends Plaza 56 Highland Avenue	4-14
4-O Average Daily Traffic Trends Plaza 57 Naperville Road	4-15
4-P Average Daily Traffic Trends Plaza 58 Winfield Road	4-15
4-Q Average Daily Traffic Trends Plaza 59 Farnsworth Avenue	4-15
4-R Average Daily Traffic Trends Plaza 60 Eola Road	4-16
4-S Average Daily Traffic Trends Plaza 61 Aurora	4-16
4-T Average Daily Traffic Trends Plaza 63 Illinois Route 31	4-16



SECTION 4 Reagan Memorial Tollway

ILLUSTRATIONS (CONTINUED)

FIGURE	PAGE
4-U Average Daily Traffic Trends Plaza 64 Orchard Road	4-17
4-V Average Daily Traffic Trends Plaza 65 Peace Road	4-17
4-W Average Daily Traffic Trends Plaza 66 DeKalb	4-17
4-X Average Daily Traffic Trends Plaza 67 Annie Glidden Road	4-18
4-Y Average Daily Traffic Trends Plaza 69 Dixon	4-18
4-Z Average Daily Traffic Trends Plaza 70 Illinois Route 26 West	4-18
4-AA Average Daily Traffic Trends Plaza 71 Illinois Route 26 East	4-19
4-AB Average Weekday Speed Distributions, Eastern Section—Eastbound	4-20
A-AC Average Weekday Speed Distributions, Eastern Section—Westbound	4-20
4-AD Average Weekday Speed Distributions, Western Section—Eastbound	4-20
4-AE Average Weekday Speed Distributions, Western Section—Westbound	4-20
4-AF Roadway Performance Measures, Eastern Section	4-21
4-AG Roadway Performance Measures, Western Section	4-22
4-AH Average Speed Contours, MP 117.0 to 140.0	4-23



This Page Is Intentionally Left Blank



TABLE 4-A: AVERAGE DAILY TRAFFIC VOLUMES BETWEEN INTERCHANGES 1980-2018 (WESTBOUND)

Location	Mile Post	Miles Btwn. Int.	ADT 1980	Average Annual Percent Change	ADT 1990	Average Annual Percent Change	ADT 2000	Average Annual Percent Change	ADT 2010	Average Annual Percent Change	ADT 2018
Eisenhower Expressway (I-290)	140.4										
		0.4	18,400	7.3	37,260	3.1	50,620	-0.7	47,270	2.7	58,460
Reagan Memorial Tollway (I-88)	140.0										
		1.1	24,050	5.4	40,610	3.6	57,780	2.0	70,480	-0.9	65,320
Harger (York) Road	138.9										
		0.2	24,690	5.5	42,130	3.6	60,170	1.8	71,920	-0.9	66,680
Tollway South Leg	138.7										
Toll Plaza 51	138.1										
Sprina Road (PL53)	137.8										
		0.7	31,670	5.9	55,970	3.1	76,280	0.3	78,570	1.8	90,930
Kingaery Highway (Illinois Route 83)	137.1										
		0.7	30,050	5.7	52,230	3.2	71,470	0.4	74,580	1.9	86,610
Midwest Road (PL55)	136.4										
Toll Plaza 52	135.1										
Highland Avenue (PL56)	134.3										
		1.1	21,780	8.2	47,890	3.7	69,030	0.5	72,210	1.8	83,360
Veterans Memorial Tollway (E. Int)	133.2										
		1.9	21,780	7.8	46,120	3.3	64,090	-0.2	62,720	1.2	69,270
Veterans Memorial Tollway (W. Int)	131.3										
		1.3	21,780	9.4	53,340	3.7	76,590	0.6	81,220	1.1	88,430
Illinois Route 53	130.0										
		2.4	15,840	11.0	44,890	4.2	68,020	0.8	73,810	1.1	80,400
Naperville Road (PL57)	127.6										
		2.4	13,130	10.1	34,280	5.7	59,400	1.4	68,510	0.8	73,210
Winfield Road (PL58)	125.2										
		1.9	13,130	10.1	34,280	3.8	49,840	2.4	63,030	1.1	68,770
Illinois Route 59	123.3										
		1.9	8,260	10.4	22,160	4.1	33,140	4.3	50,400	0.9	54,180
Eola Road (PL60)	121.4										
		2.2	8,260	10.4	22,160	4.1	33,140	3.9	48,470	0.7	51,170
Farnsworth Avenue (PL59)	119.2										
Toll Plaza 61	117.8										
Illinois Route 31 (PL63)	117.0										
		2.6	5,340	9.6	13,320	3.6	18,990	5.3	31,690	0.5	33,080
Orchard Road (PL64)	114.4										
		1.1	5,340	7.9	11,420	2.8	15,110	3.9	22,100	-0.3	21,590
Illinois Route 56	113.3										
		4.0	3,170	7.7	6,680	3.8	9,710	3.5	13,740	-1.8	11,870
Illinois Route 47	109.3										
		15.3	3,640	7.4	7,440	4.0	11,020	3.4	15,350	-1.8	13,270
Peace Road (PL65)	94.0										
		0.7	2,550	7.4	5,230	5.2	8,680	3.7	12,440	-3.5	9,360
DeKalb Oasis	93.3										
		1.9	2,550	7.4	5,230	5.2	8,680	3.7	12,440	-3.5	9,360
Annie Glidden Road (PL67)	91.4										
Toll Plaza 66	86.2										
Interstate 39	78.5										
		2.4	2,010	8.4	4,500	4.8	7,200	1.8	8,610	-0.5	8,240
U.S. Route 51 (Illinois Route 251)	76.1										
Toll Plaza 69	56.4										
Illinois Route 26 (Dixon)	53.9										
		9.7	2,510	4.3	3,820	4.5	5,920	2.0	7,220	0.1	7,260
U.S. Route 30 West Terminus	44.2										
Reagan Connector		1.4	7,100	6.4	13,220	1.4	15,250	2.4	19,260	1.2	21,230



TABLE 4-B: AVERAGE DAILY TRAFFIC VOLUMES BETWEEN INTERCHANGES 1980-2018 (EASTBOUND)

Location	Mile Post	Miles Btwn. Int.	ADT 1980	Average Annual Percent Change	ADT 1990	Average Annual Percent Change	ADT 2000	Average Annual Percent Change	ADT 2010	Average Annual Percent Change	ADT 2018
Eisenhower Expressway (I-290)	140.4										
		0.4	15,290	6.7	29,300	4.3	44,490	0.7	47,580	1.7	54,280
Reagan Memorial Tollway (I-88)	140.0										
		1.1	21,750	5.0	35,360	4.2	53,170	0.3	54,630	2.0	64,100
Harger (York) Road	138.9										
		0.2	21,750	5.0	35,360	4.2	53,170	0.3	54,630	2.0	64,100
Reagan Connector	138.7										
Toll Plaza 51	138.1										
Spring Road	137.8										
		0.7	30,390	5.6	52,500	3.1	71,030	0.8	76,930	2.1	90,560
Illinois Route 83 (PL54)	137.1										
		0.7	27,930	5.5	47,610	3.0	64,000	0.8	69,510	2.1	81,910
Midwest Road (PL55)	136.4										
Toll Plaza 52	135.1										
Highland Avenue (PL56)	134.3										
		1.1	22,500	7.5	46,280	4.0	68,610	0.8	74,300	1.8	85,710
Veterans Memorial Tollway (E. Int)	133.2										
		1.9	22,500	8.6	51,280	4.4	78,680	0.2	80,450	1.0	87,000
Veterans Memorial Tollway (W. Int)	131.3										
		1.3	22,500	8.9	52,980	3.9	77,900	0.4	81,280	0.9	87,130
Illinois Route 53	130.0										
		2.4	16,500	10.5	44,710	4.4	68,790	0.9	74,980	0.9	80,530
Naperville Road	127.6										
		2.4	13,620	9.8	34,550	5.5	59,040	1.7	70,040	0.3	71,880
Winfield Road (PL58)	125.2										
		1.9	13,620	9.8	34,550	3.9	50,840	2.5	64,810	0.3	66,120
Illinois Route 59	123.3										
		1.9	8,740	10.0	22,610	4.1	33,790	4.3	51,490	1.0	55,590
Eola Road (PL60)	121.4										
		2.2	8,740	10.0	22,610	4.1	33,790	3.7	48,630	0.7	51,220
Farnsworth Avenue (PL59)	119.2										
Toll Plaza 61	117.8										
Illinois Route 31 (PL63)	117.0										
		2.6	5,500	9.4	13,560	3.5	19,170	5.2	31,930	0.7	33,670
Orchard Road (PL64)	114.4										
		1.1	5,500	7.7	11,510	3.5	16,160	3.1	21,860	-0.2	21,590
Illinois Route 56	113.3										
		4.0	3,110	8.0	6,690	3.8	9,720	3.4	13,580	-1.7	11,850
Illinois Route 47	109.3										
		15.3	3,570	7.6	7,400	4.0	10,990	3.2	15,090	-1.7	13,150
Peace Road (PL65)	94.0										
		0.7	2,620	7.4	5,370	5.1	8,800	3.4	12,270	-3.2	9,430
DeKalb Oasis	93.3										
		1.9	2,620	7.4	5,370	5.1	8,800	3.4	12,270	-3.2	9,430
Annie Glidden Road (PL67)	91.4										
Toll Plaza 66	86.2										
Interstate 39	78.5										
		2.4	2,050	8.4	4,580	4.6	7,190	1.8	8,560	-0.5	8,250
Illinois Route 251	76.1										
Toll Plaza 69	56.4										
Illinois Route 26	53.9										
		9.7	2,460	4.4	3,780	4.7	6,010	1.6	7,030	0.5	7,330
U.S. Route 30 West Terminus	44.2										
Reagan Connector		1.4	7,050	6.5	13,180	-0.5	12,500	4.4	19,260	2.8	24,070



**TABLE 4-C: GENERAL STATISTICS FOR MAINLINE PLAZAS
(Vehicles/Hour)**

Mainline Plaza	Dir.	30th HV	Period	Mean	Med.	Max.	Min.	Std. Dev.	85th %
51 York Road	WB	7,523	AM Peak	5,971	5,426	7,820	2,589	1,139	7,253
			PM Peak	6,833	6,913	7,701	3,415	467	7,202
			OFF Peak	3,407	3,704	7,735	194	2,134	5,765
			Weekend	3,398	3,473	7,523	268	1,954	5,429
			Holidays	2,998	3,002	7,400	234	1,836	4,975
52 Meyers Road	EB	8,005	AM Peak	7,202	7,247	8,412	4,170	670	7,773
			PM Peak	6,242	6,267	7,357	4,026	485	6,694
			OFF Peak	3,287	3,639	8,114	181	2,138	5,479
			Weekend	3,257	3,370	7,920	267	1,993	5,351
			Holidays	2,883	2,926	7,222	279	1,803	4,914
61 Aurora	EB	4,939	AM Peak	4,568	4,656	5,148	1,831	415	4,860
			PM Peak	2,525	2,522	3,053	1,372	192	2,707
			OFF Peak	1,519	1,530	4,889	99	1,025	2,585
			Weekend	1,600	1,587	5,058	130	1,046	2,621
			Holidays	1,458	1,495	4,520	107	965	2,471
	WB	5,128	AM Peak	1,854	1,721	2,411	849	328	2,238
			PM Peak	4,768	4,826	5,433	2,725	341	5,027
			OFF Peak	1,511	1,673	4,915	64	1,042	2,412
			Weekend	1,548	1,562	5,406	134	1,034	2,405
			Holidays	1,400	1,340	4,949	92	993	2,274
66 DeKalb	EB	941	AM Peak	332	306	514	208	84	455
			PM Peak	505	483	1,038	295	112	621
			OFF Peak	272	265	1,066	27	171	460
			Weekend	337	311	1,485	22	234	595
			Holidays	323	272	916	16	244	627
	WB	914	AM Peak	399	394	666	154	84	473
			PM Peak	460	441	841	290	98	568
			OFF Peak	279	251	978	25	178	479
			Weekend	340	334	1,335	17	226	589
			Holidays	327	287	983	19	241	609

(cont'd)

**TABLE 4-C: GENERAL STATISTICS FOR MAINLINE PLAZAS
(Vehicles/Hour)**

Mainline Plaza	Dir.	30th HV	Period	Mean	Med.	Max.	Min.	Std. Dev.	85th %
69 Dixon	EB	913	AM Peak	276	274	376	110	33	311
			PM Peak	444	436	745	202	76	519
			OFF Peak	253	230	888	26	152	419
			Weekend	326	291	1,258	19	228	589
			Holidays	316	259	1,044	15	245	593
	WB	863	AM Peak	338	340	549	146	48	385
			PM Peak	424	422	650	219	56	480
			OFF Peak	261	239	919	13	151	428
			Weekend	323	310	1,311	16	214	572
			Holidays	321	263	978	19	244	605

AM Peak = Weekday 6:00 AM To 8:00 AM Except Fridays
 PM Peak = Weekday 4:00 PM To 6:00 PM Except Fridays
 OFF Peak = Weekdays Except Fridays and AM and PM Peak Periods
 Weekend = Fridays, Saturdays, and Sundays
 Holidays = See Page 1-6 for a list of Holidays.

TABLE 4-D: INDEXED MONTHLY VARIATION BY MAINLINE PLAZA

Month	York Road	Meyers Road	Aurora	DeKalb	Dixon
January	0.92	0.92	0.91	1.07	0.85
February	0.95	0.95	0.95	1.11	0.89
March	1.03	1.03	1.04	1.31	1.07
April	1.03	1.03	1.03	1.03	0.99
May	1.03	1.06	1.05	1.02	1.05
June	1.05	1.08	1.05	0.99	1.07
July	1.01	1.02	1.02	0.95	1.07
August	1.04	1.01	1.04	0.93	1.09
September	1.00	0.97	0.99	0.86	0.99
October	1.02	1.00	1.02	0.86	0.97
November	0.97	0.96	0.96	0.92	0.99
December	0.96	0.96	0.94	0.96	0.95

TABLE 4-E: INDEXED DAILY VARIATION BY MAINLINE PLAZA

Month	Day	York Road	Meyers Road	Aurora	DeKalb	Dixon
August	Monday	1.05	1.04	1.05	0.90	1.06
	Tuesday	1.02	1.00	1.02	0.89	1.06
	Wednesday	1.03	1.00	1.02	0.90	1.08
	Thursday	1.02	1.00	1.02	0.91	1.07
	Friday	1.02	1.00	1.03	0.92	1.08
	Saturday	1.05	0.98	1.02	0.95	1.10
	Sunday	1.05	1.00	1.02	0.97	1.13
December	Monday	0.93	0.93	0.93	0.91	0.89
	Tuesday	0.91	0.93	0.92	0.96	0.95
	Wednesday	0.98	0.99	0.98	1.08	1.06
	Thursday	0.97	0.98	0.97	0.96	0.99
	Friday	1.00	1.00	0.98	0.96	0.97
	Saturday	1.00	1.01	0.98	1.01	1.01
	Sunday	0.97	0.97	0.93	0.87	0.86

Table 4-E includes Monthly Variation

TABLE 4-F: ANNUAL TOTAL TRANSACTIONS BY TOLL PLAZA

Plaza	Plaza Code*	2017	2018	Percentage Change
51 York Road	M1	33,856,163	32,087,357	-5.2%
52 Meyers Road	M1	32,837,946	31,314,151	-4.6%
53 Spring Road	R1	3,189,916	3,146,225	-1.4%
54 Illinois Route 83	R1	3,102,316	3,155,501	1.7%
55 Midwest Road	R1	1,606,728	1,607,713	0.1%
56 Highland Avenue	R	5,624,432	5,555,877	-1.2%
57 Naperville Road	R	4,106,617	4,020,315	-2.1%
58 Winfield Road	R	2,770,841	2,681,600	-3.2%
59 Farnsworth Avenue	R	9,456,121	9,627,473	1.8%
60 Eola Road	E	4,070,890	3,808,274	-6.5%
61 Aurora	M	31,726,491	29,985,120	-5.5%
63 Illinois Route 31	R	1,292,846	1,164,608	-9.9%
64 Orchard Road	R	1,595,095	1,322,665	-17.1%
65 Peace Road	R	3,515,929	3,305,859	-6.0%
66 DeKalb Mainline	M	7,746,809	5,554,610	-28.3%
67 Annie Glidden Road	R	1,992,380	1,346,265	-32.4%
69 Dixon Mainline	M	5,576,665	5,213,591	-6.5%
Reagan Memorial Total		154,068,185	144,897,204	-6.0%

* M=Mainline / R=Ramp / A=Attended Ramp Plaza / E=Electronic Toll Collection Only Ramp
 1=Toll Collected in One Direction Only



TABLE 4-G: AVERAGE DAILY TRAFFIC DATA

Year	Average Daily Total			Average Trip
	Vehicles	Vehicle Miles	Transactions	Length (Miles)
1959	8,440	165,204	12,808	19.57
1960	12,276	203,116	16,744	16.55
1961	16,312	257,837	21,563	15.81
1962	17,764	288,501	24,029	16.24
1963	16,569	279,454	23,257	16.87
1964	16,995	264,758	21,574	15.58
1965	17,995	271,692	22,776	15.10
1966	17,947	285,535	25,748	15.91
1967	19,729	311,452	28,672	15.79
1968	22,809	341,062	31,370	14.95
1969	26,158	389,376	36,732	14.89
1970	29,164	429,270	41,225	14.72
1971	31,899	477,703	46,504	14.98
1972	37,858	538,511	52,714	14.22
1973	43,598	599,398	59,488	13.75
1974	41,427	634,698	61,858	15.32
1975	46,937	824,125	74,039	17.56
1976	51,443	907,679	80,957	17.64
1977	52,795	942,618	83,086	17.85
1978	62,128	1,141,523	98,673	18.37
1979	65,025	1,209,224	102,678	18.60
1980	66,901	1,237,492	106,458	18.50
1981	69,977	1,237,492	112,541	17.68
1982	73,089	1,366,570	124,900	18.70
1983	83,292	1,501,330	126,523	18.02
1984	89,716	1,619,407	137,718	18.05
1985	95,566	1,760,944	148,154	18.43
1986	104,972	1,933,134	166,784	18.42
1987	113,033	2,064,188	180,166	18.26
1988	118,956	2,211,706	190,996	18.59
1989	119,346	2,289,542	196,542	19.18
1990	129,849	2,587,888	212,457	19.93
1991	132,723	2,552,325	207,433	19.23
1992	139,437	2,722,109	216,466	19.52
1993	148,050	2,846,936	224,192	19.23
1994	154,551	3,146,111	246,079	20.36
1995	162,260	3,357,807	259,860	20.69
1996	167,010	3,477,775	275,061	20.82
1997	186,370	3,471,458	274,429	18.63
1998	200,930	3,492,638	274,660	17.38
1999	214,190	3,824,597	298,242	17.86
2000	218,150	3,900,147	305,567	17.88
2001	226,930	4,006,550	316,753	17.66
2002	232,780	4,288,781	341,362	18.42
2003	239,380	4,478,762	348,386	18.71
2004	243,640	4,606,017	359,964	18.91
2005	238,580	4,441,784	350,311	18.62
2006	240,500	4,540,450	359,564	18.88
2007	243,310	4,603,873	359,357	18.92
2008	239,410	4,344,648	333,079	18.15
2009	243,680	4,417,393	336,193	18.13
2010	239,680	4,650,235	372,523	19.40
2011	255,540	4,925,591	392,112	19.28
2012	242,590	4,596,370	373,479	18.95
2013	236,900	4,809,676	386,982	20.30
2014	239,890	4,999,058	398,674	20.84
2015	247,280	5,061,140	411,023	20.47
2016	250,550	5,182,530	417,787	20.68
2017	251,860	5,148,124	422,105	20.44
2018	249,280	4,824,574	396,979	19.35

FIGURE 4-B

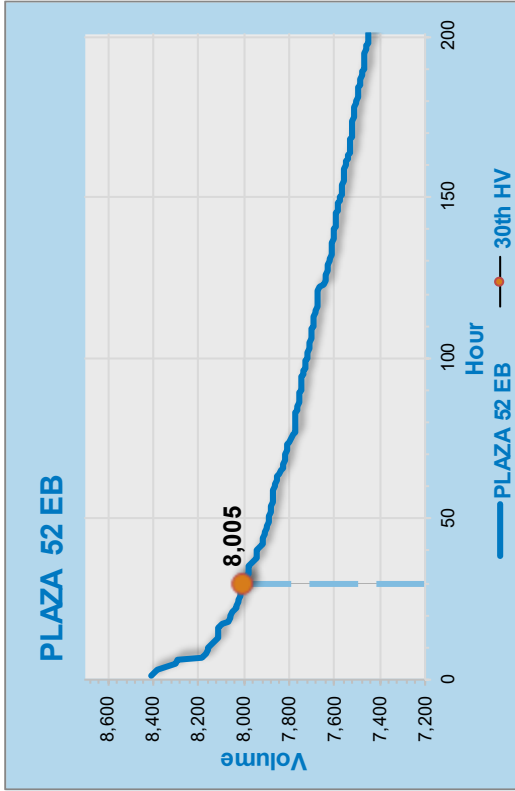

FIGURE 4-D

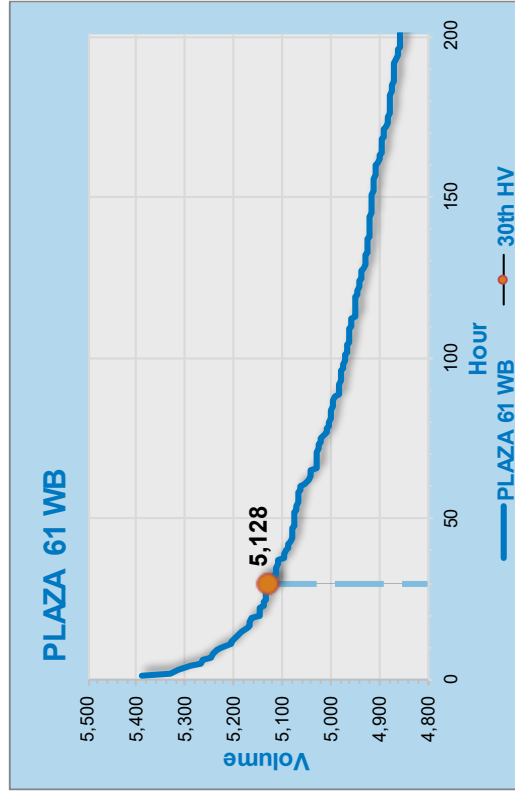

FIGURE 4-A

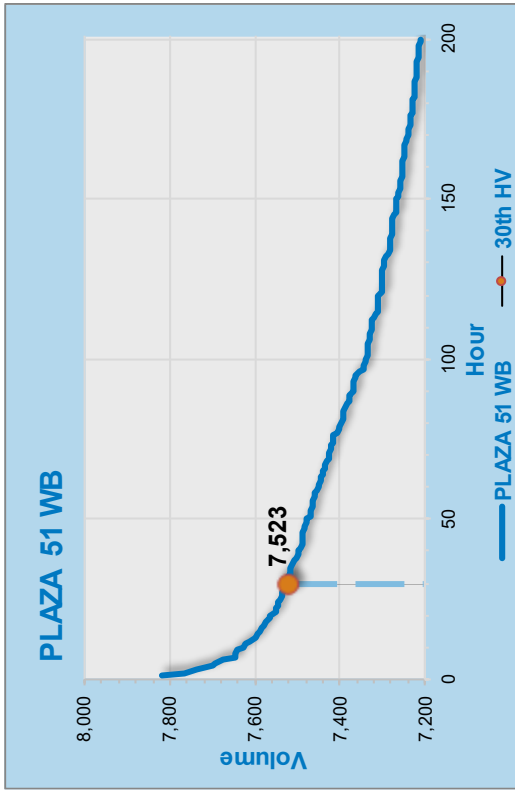
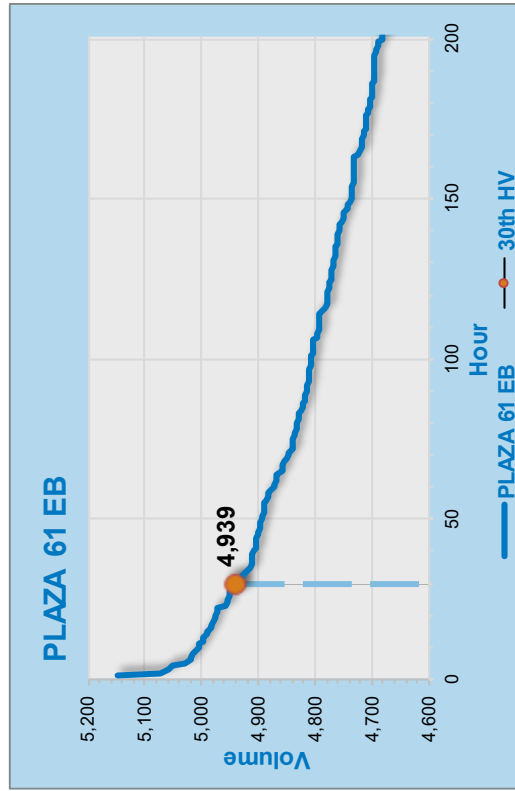

FIGURE 4-C



MAINLINE PLAZA HIGHEST HOURLY VOLUME

FIGURE 4-F

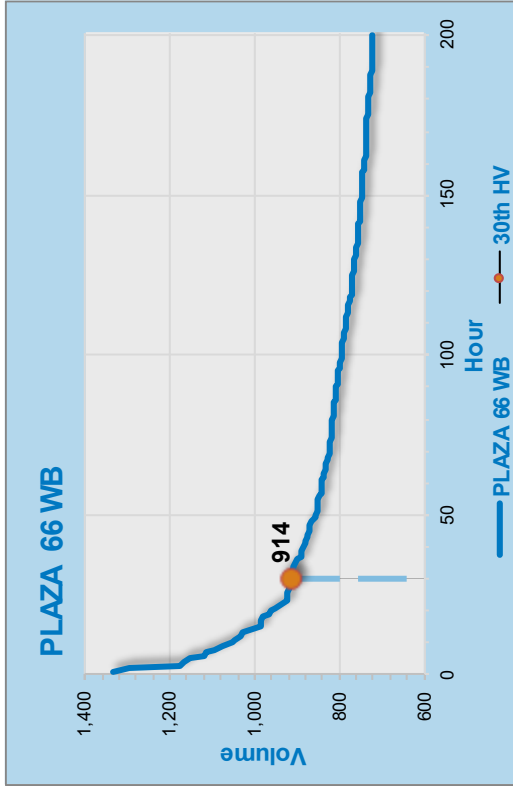

FIGURE 4-H

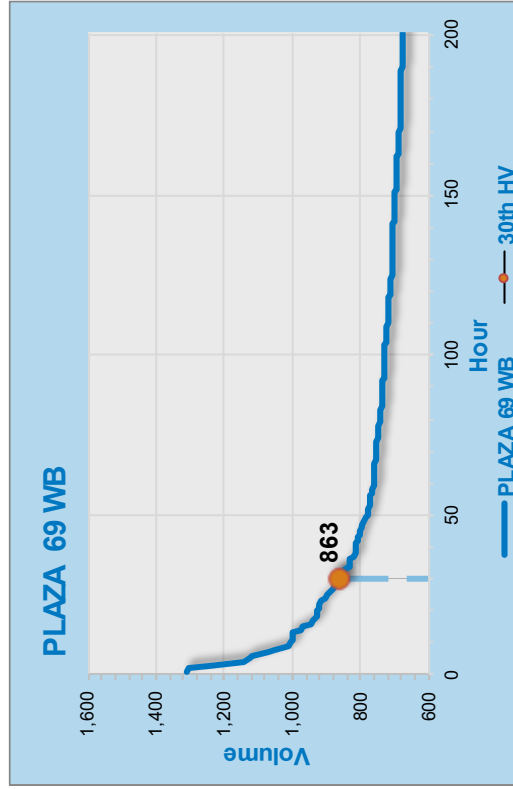

FIGURE 4-E

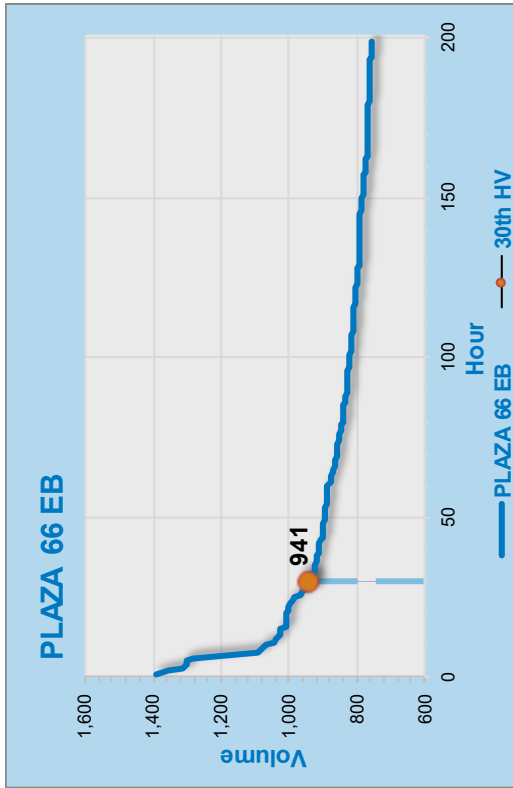
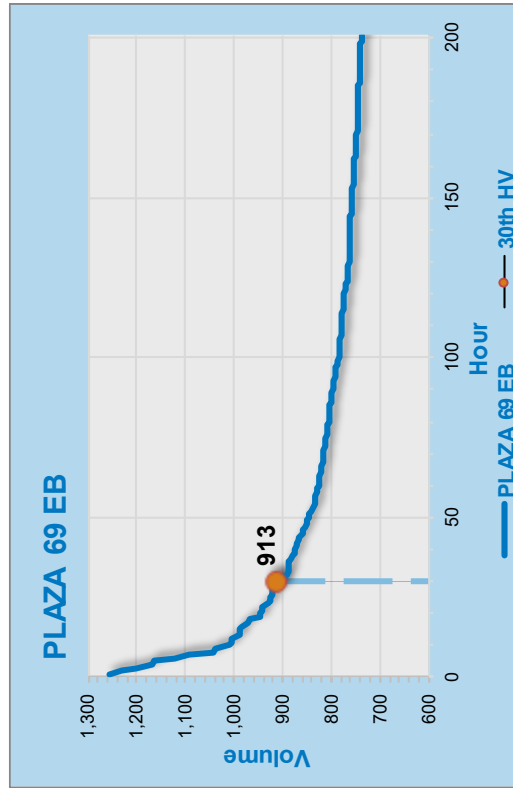

FIGURE 4-G



MAINLINE PLAZA HIGHEST HOURLY VOLUME

FIGURE 4-I

The eastbound side of Plaza 51 closed in 2006 and was replaced by Plaza 52.

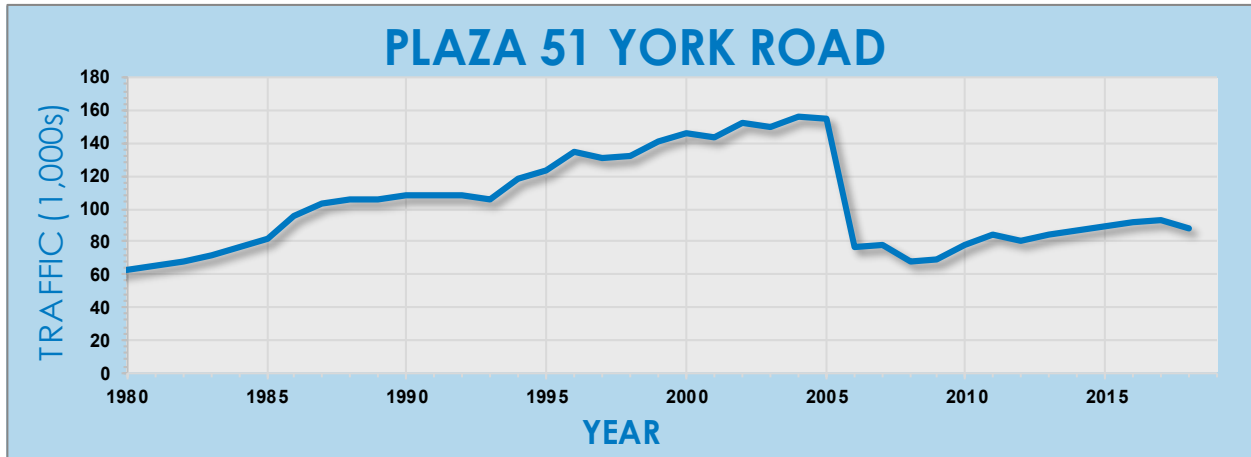

FIGURE 4-J

Plaza 52 opened in 2006 to replace eastbound Plaza 51.

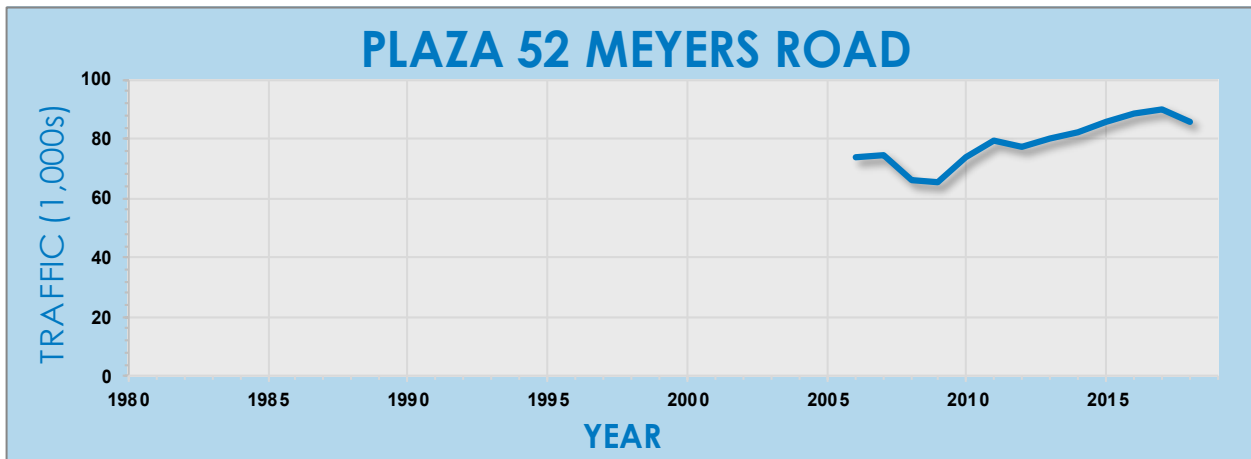
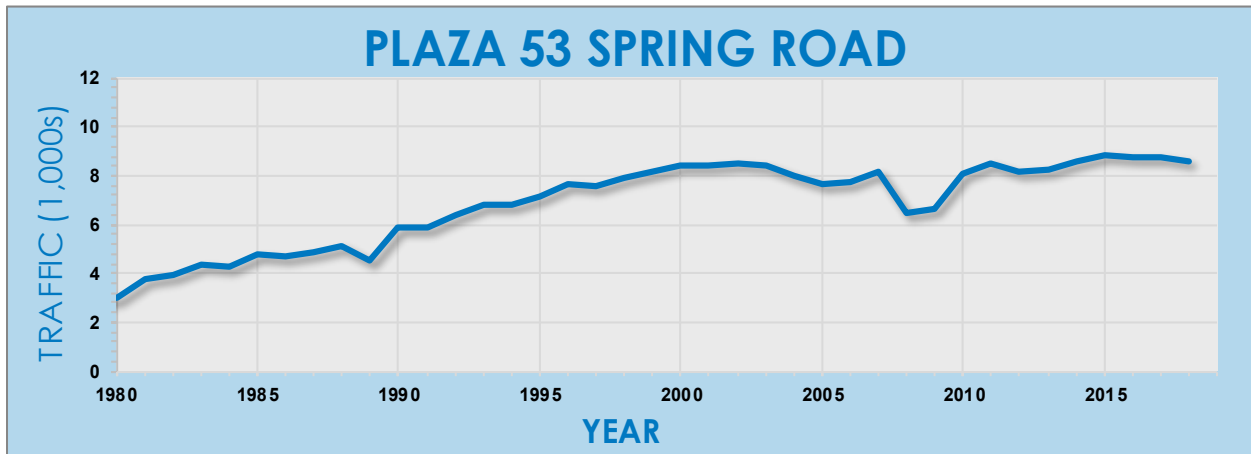

FIGURE 4-K



AVERAGE DAILY TRAFFIC TRENDS

FIGURE 4-L

Plaza 54 opened in 2006 due to Plaza 51 reconfiguration.

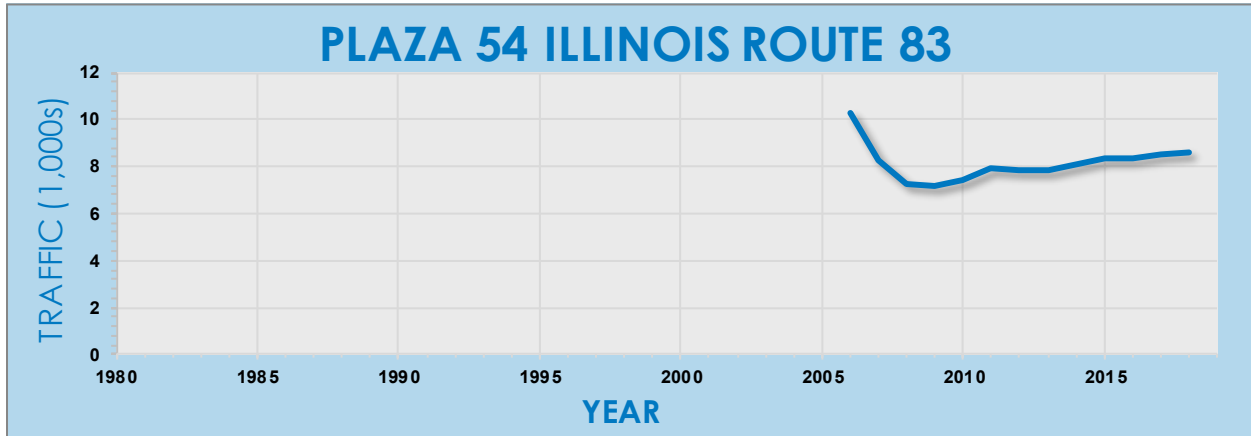

FIGURE 4-M

Plaza 55 was moved from the exit ramp to the entrance ramp in 2006 due to Plaza 51 reconfiguration..

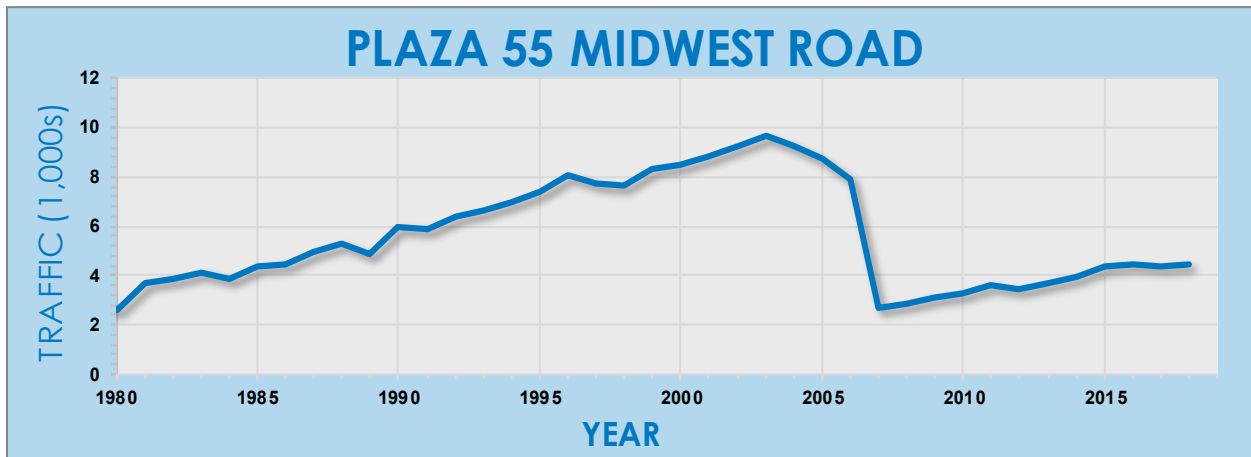
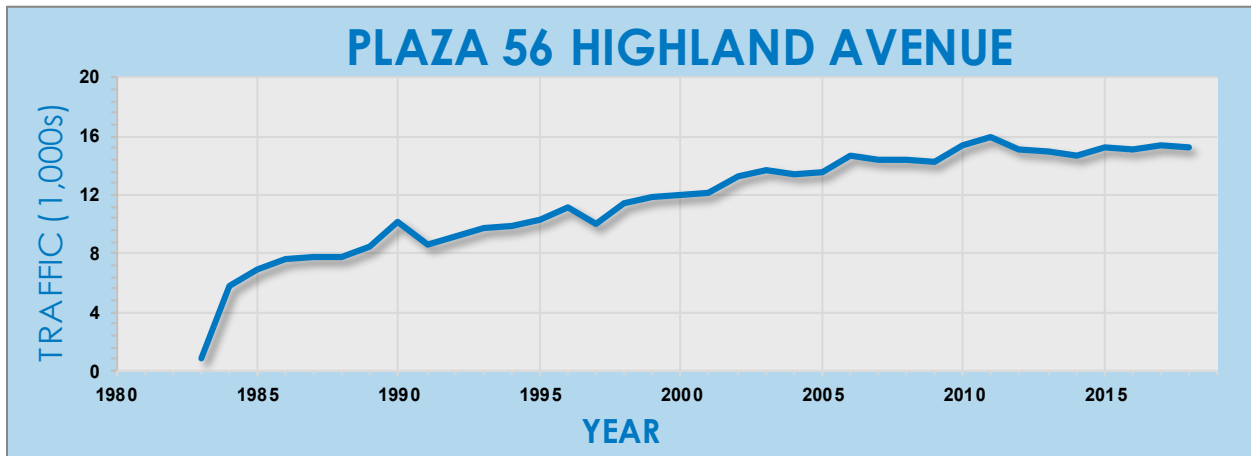

FIGURE 4-N



AVERAGE DAILY TRAFFIC TRENDS

FIGURE 4-O

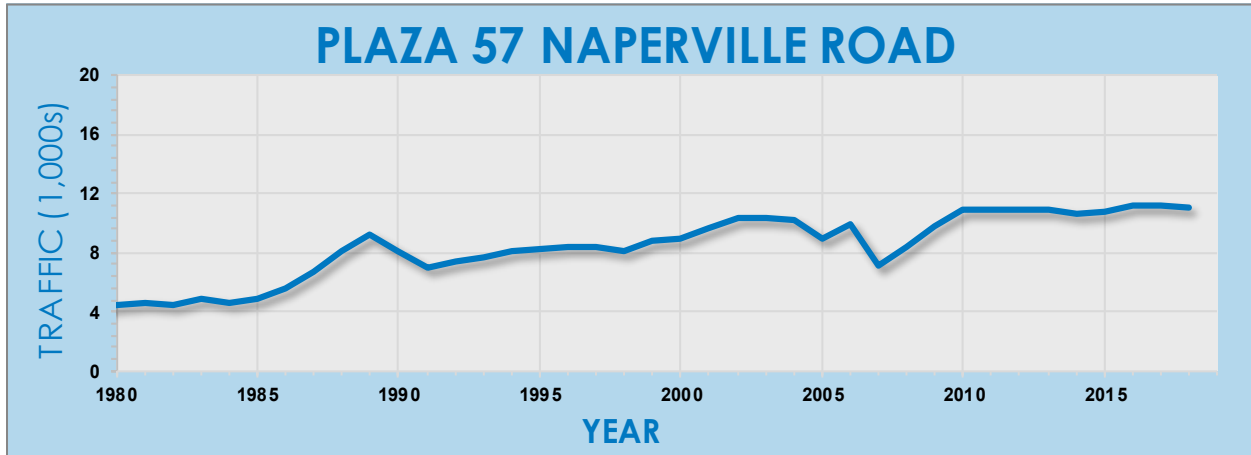

FIGURE 4-P

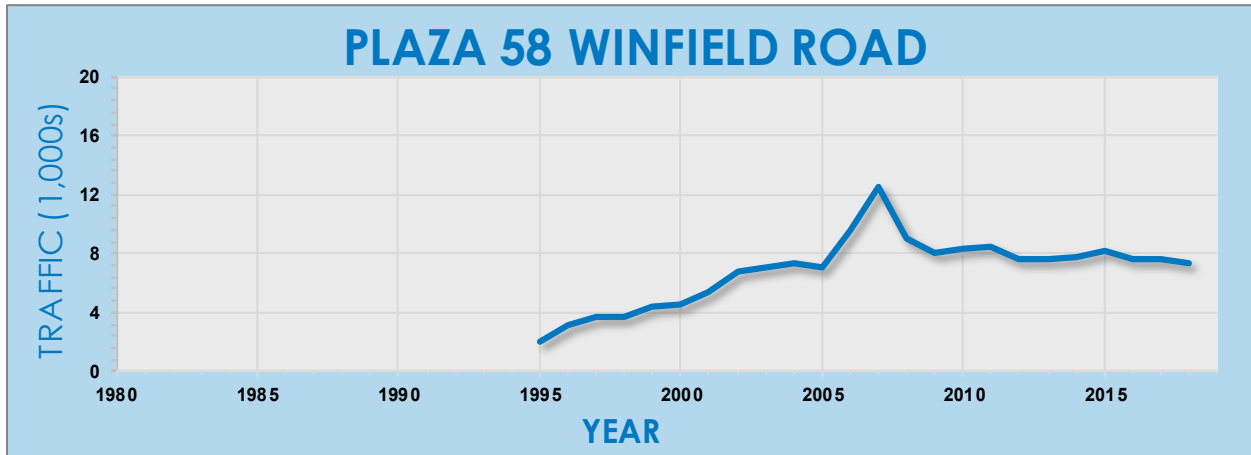
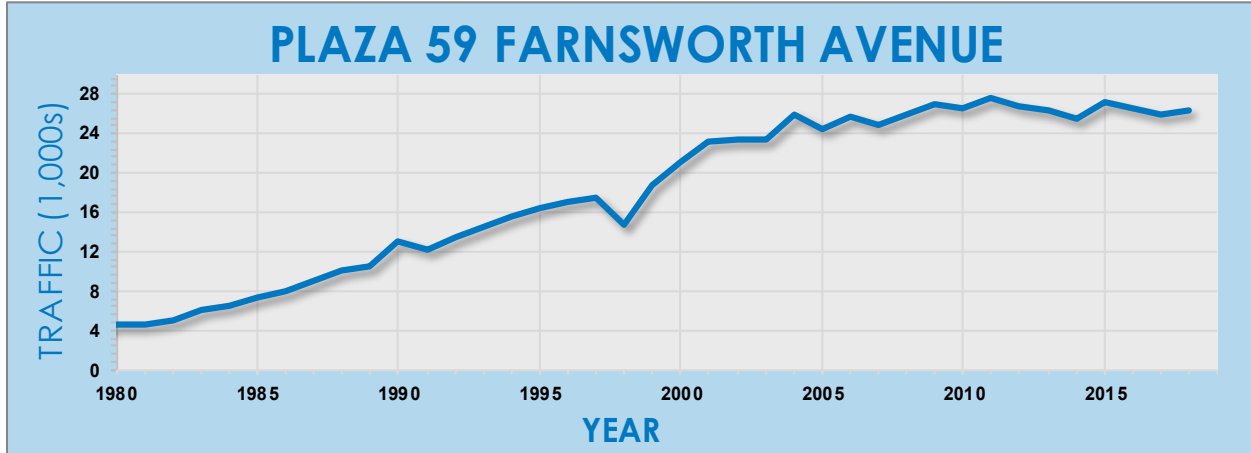

FIGURE 4-Q



AVERAGE DAILY TRAFFIC TRENDS



FIGURE 4-R

Plaza 60 opened in 2009.

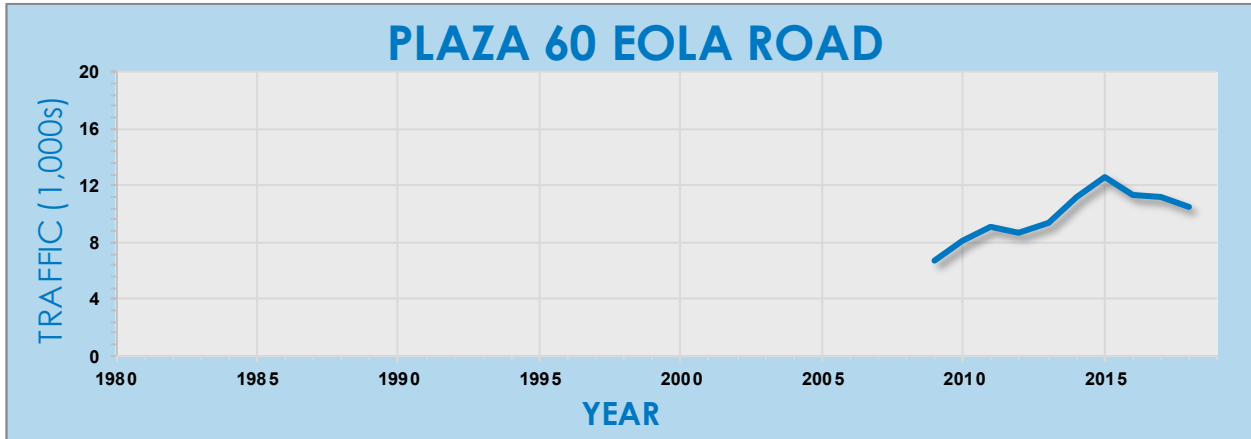

FIGURE 4-S

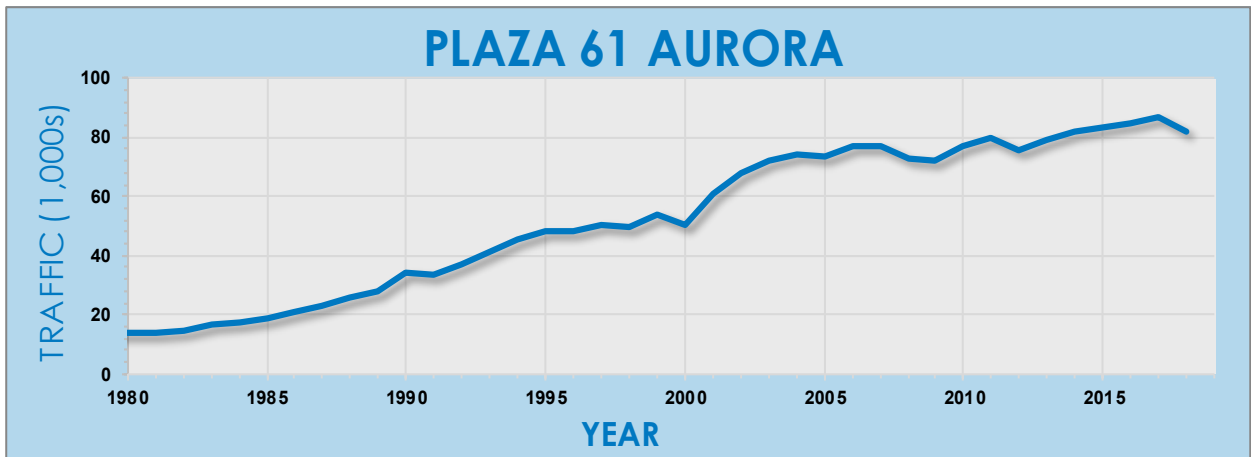
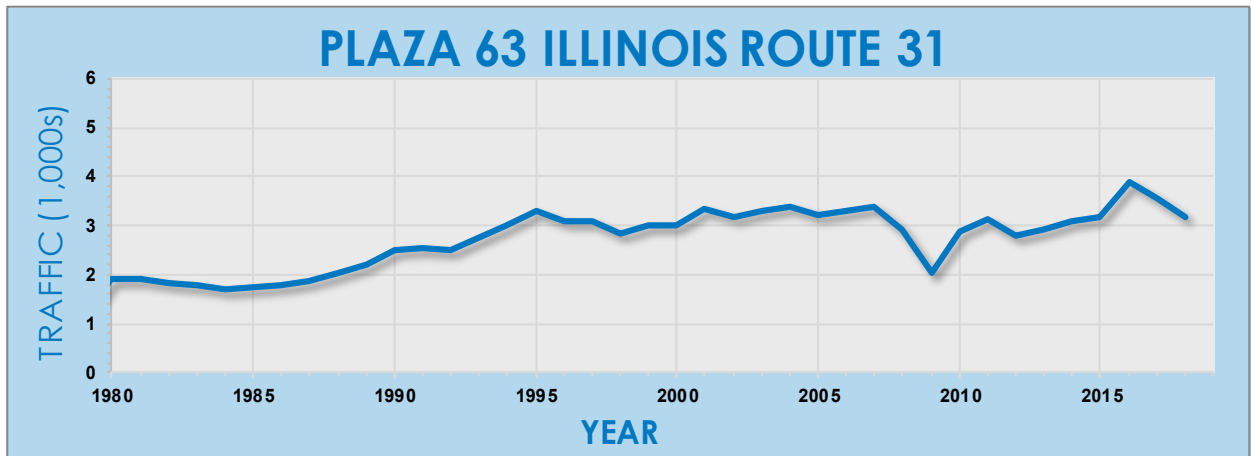

FIGURE 4-T



AVERAGE DAILY TRAFFIC TRENDS



FIGURE 4-U

Plaza 64 opened in 1997

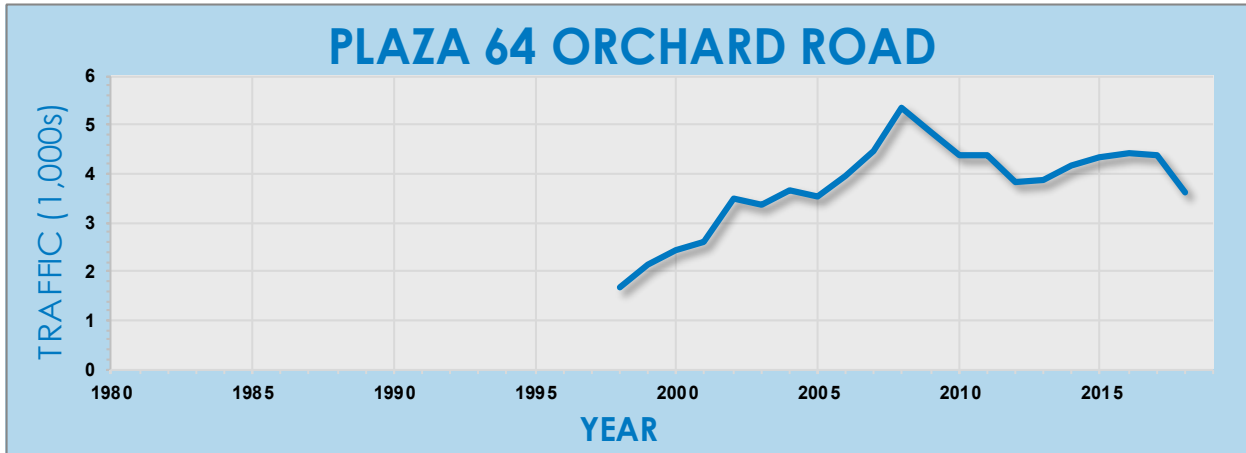

FIGURE 4-V

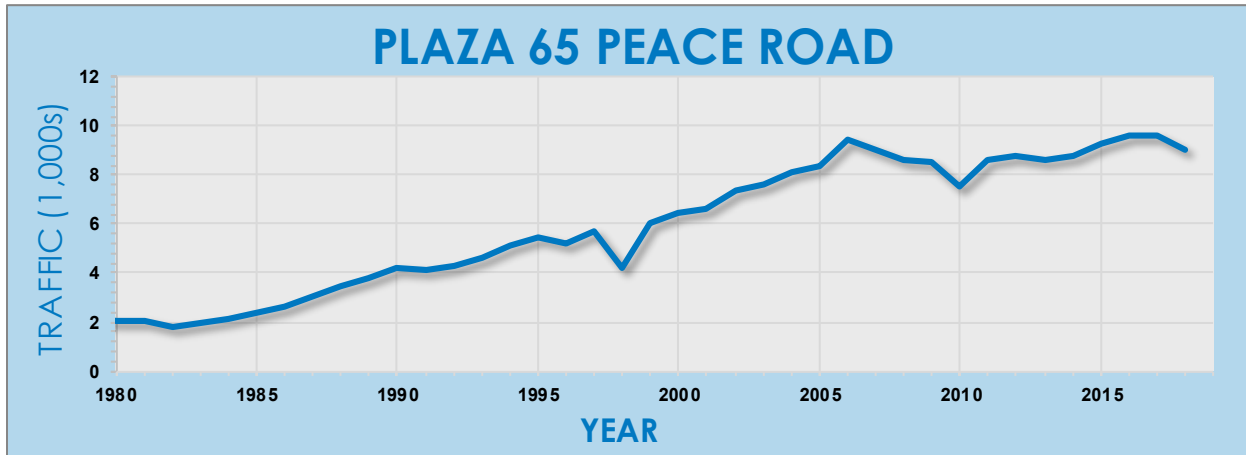

FIGURE 4-W



AVERAGE DAILY TRAFFIC TRENDS

FIGURE 4-X

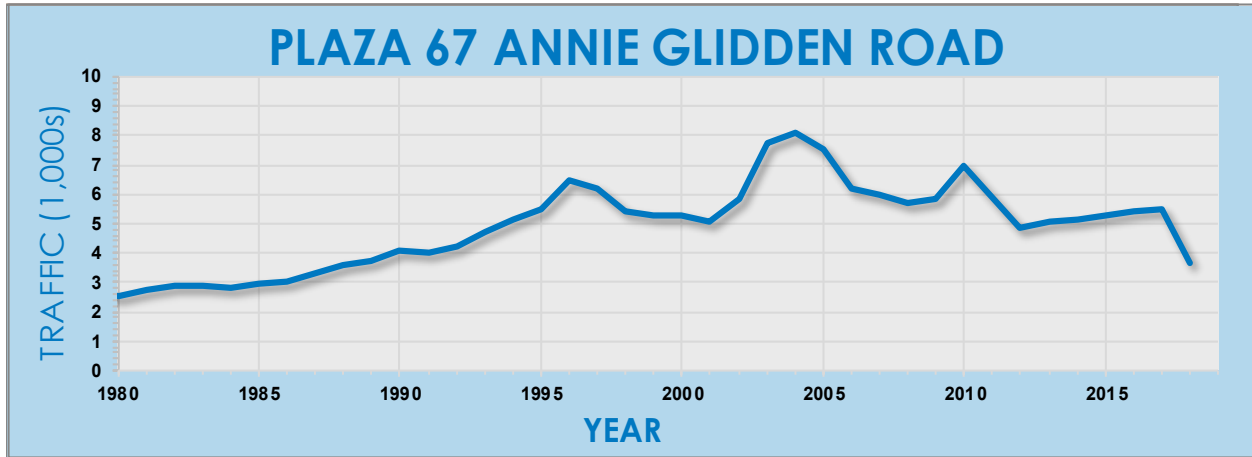

FIGURE 4-Y

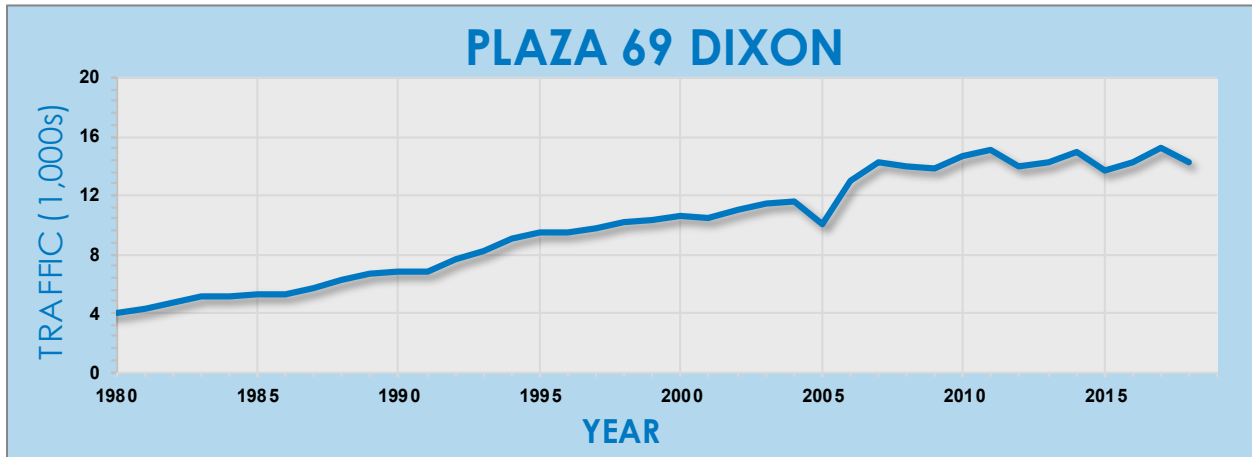
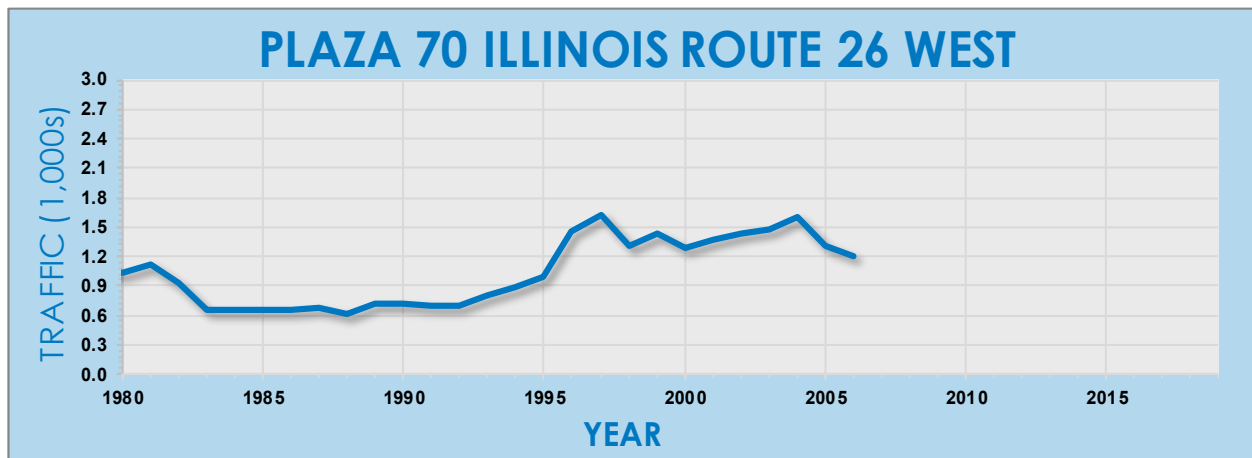

FIGURE 4-Z

Plaza 70 was removed in 2006.



AVERAGE DAILY TRAFFIC TRENDS



FIGURE 4-AA

Plaza 71 was removed in 2006.

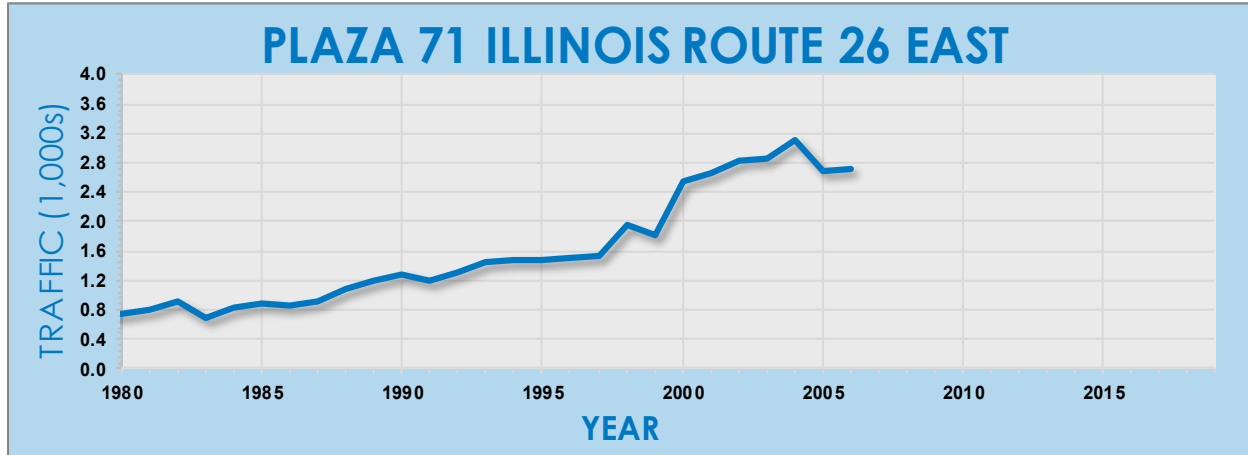

AVERAGE DAILY TRAFFIC TRENDS

AVERAGE WEEKDAY SPEED DISTRIBUTIONS, EASTERN SECTION

FIGURE 4-AB

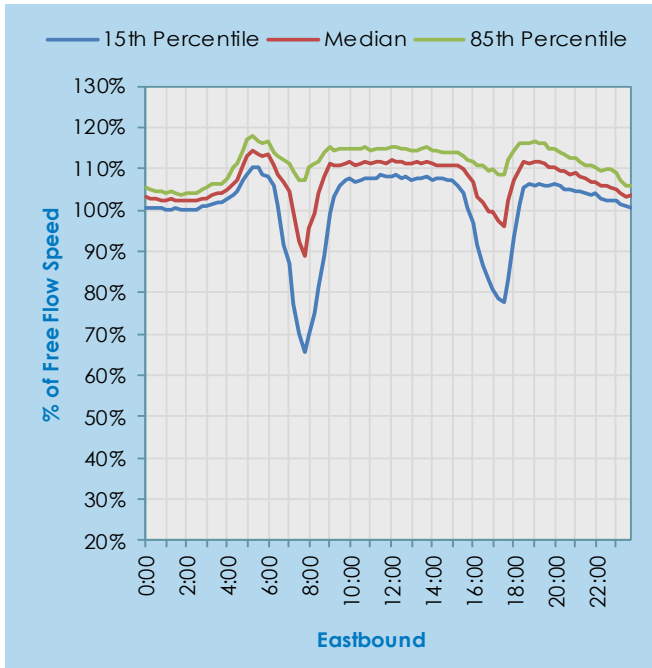
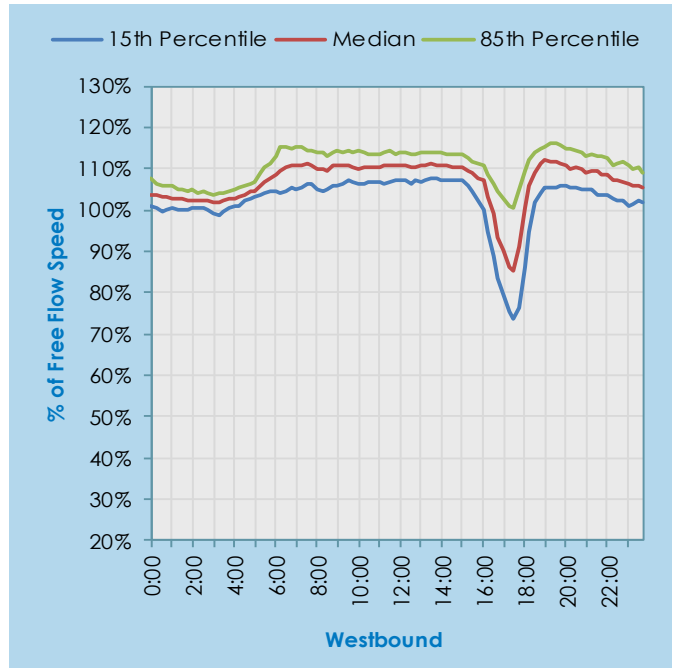

FIGURE 4-AC



AVERAGE WEEKDAY SPEED DISTRIBUTIONS, WESTERN SECTION

FIGURE 4-AD

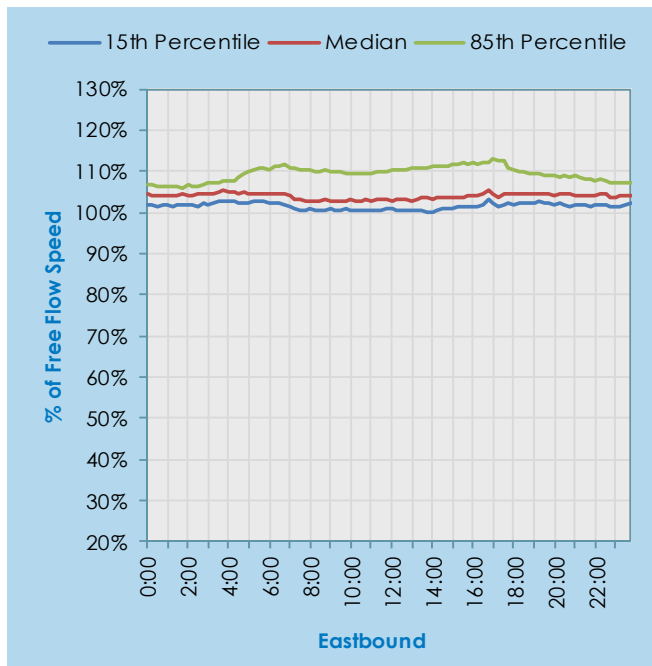
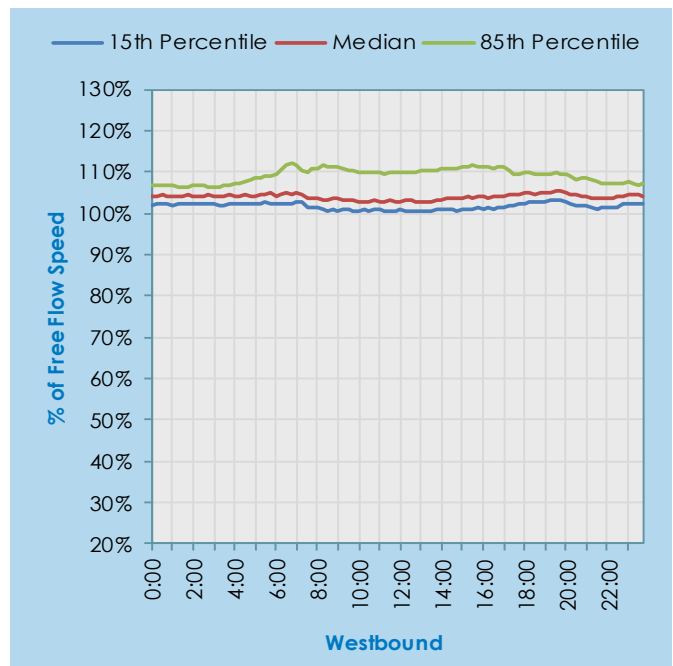
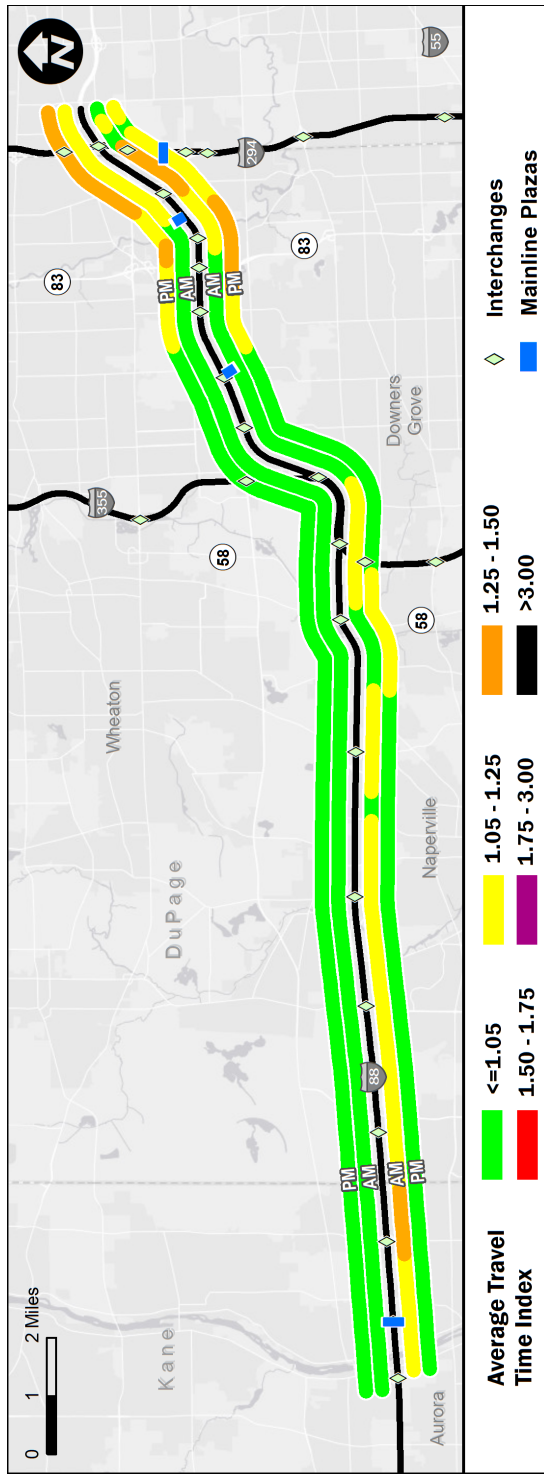

FIGURE 4-AE





Quarter	Range	Average Speed (mph)		Average Travel Time Index		Planning Time Index		Total Delay (veh-hrs / 1000 VMT)		Average Daily Delay (veh-hrs)		Percent Congested Travel	
		AM	PM	AM	PM	AM	PM	AM	PM	AM	PM	AM	PM
1	January-March	60	64	1.01	0.93	1.41	1.00	1.3	0.6	972	469	20	16
2	April-June	59	60	1.03	1.01	1.19	1.11	1.5	1.5	1,065	1,049	25	27
3	July-September	61	62	0.99	0.97	1.11	1.04	1.2	0.6	907	446	23	21
4	October-December	58	58	1.04	1.03	1.13	1.13	1.9	1.5	1,386	1,004	29	30
Total	2018 Entire Year	59	61	1.02	0.98	1.21	1.07	1.5	1.1	1,082	742	24	23

Data source: INRIX. Roadway performance measures sections and terms are defined on pages 1-4 and 1-5.

FIGURE 4-AF: ROADWAY PERFORMANCE MEASURES—EASTERN SECTION

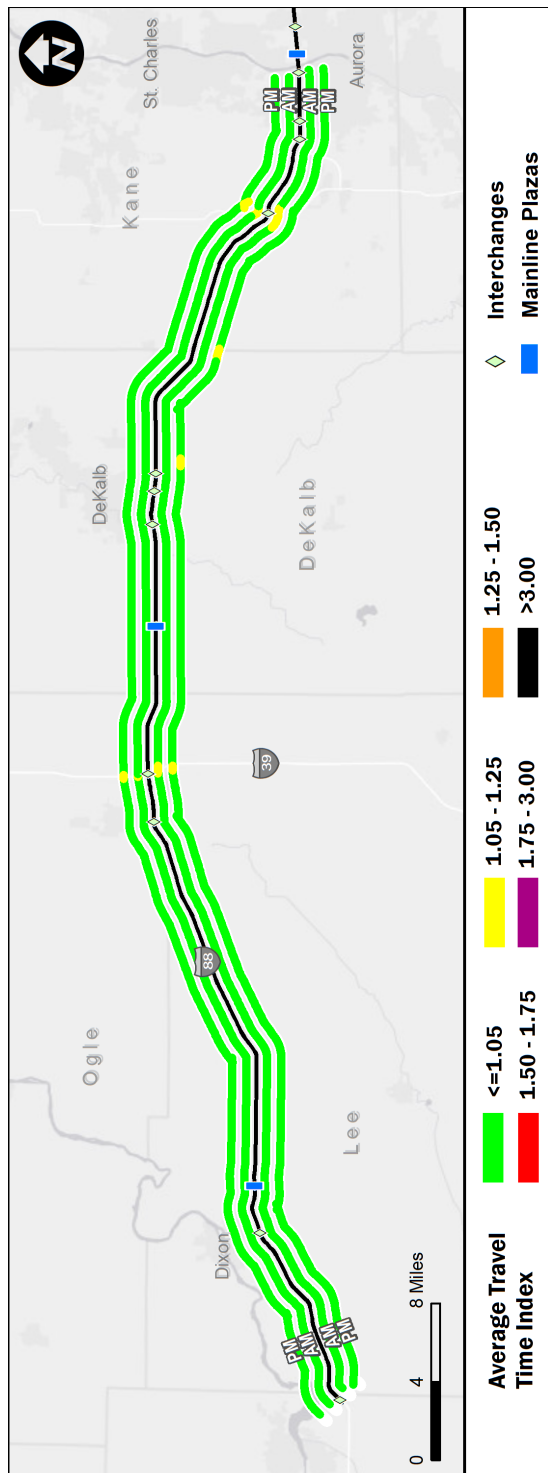

Quarter	Range	Average Speed (mph)		Average Travel Time Index		Planning Time Index		Total Delay (veh-hrs / 1000 VMT)		Average Daily Delay (veh-hrs)		Percent Congested Travel	
		AM	PM	AM	PM	AM	PM	AM	PM	AM	PM	AM	PM
1	January-March	65	62	0.92	0.97	0.96	0.98	0.2	0.6	52	118	3	42
2	April-June	66	61	0.90	0.98	0.93	0.98	0.1	0.6	17	175	2	43
3	July-September	61	63	0.98	0.96	0.99	0.99	0.6	0.3	127	66	37	27
4	October-December	61	62	0.98	0.96	1.01	0.98	0.7	0.4	187	111	38	27
Total	2018 Entire Year	64	62	0.94	0.97	0.97	0.98	0.4	0.5	96	117	20	35

Data source: INRIX. Roadway performance measures sections and terms are defined on pages 1-4 and 1-5.

FIGURE 4-AG: ROADWAY PERFORMANCE MEASURES—WESTERN SECTION

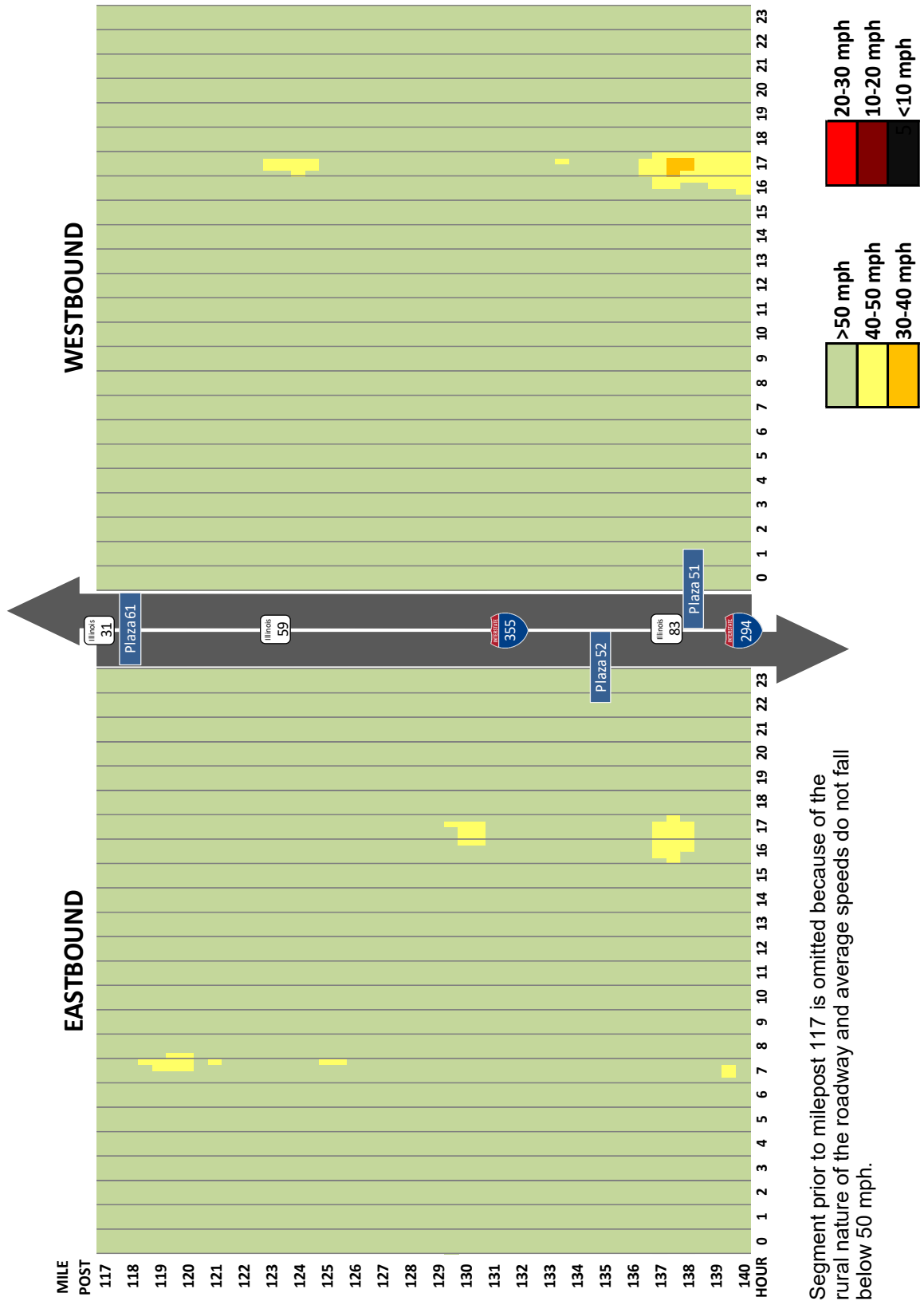

Segment prior to milepost 117 is omitted because of the rural nature of the roadway and average speeds do not fall below 50 mph.

FIGURE 4-AH: AVERAGE SPEED CONTOURS, MP 117.0 TO 140.0

This Page Is Intentionally Left Blank

Veterans Memorial Tollway

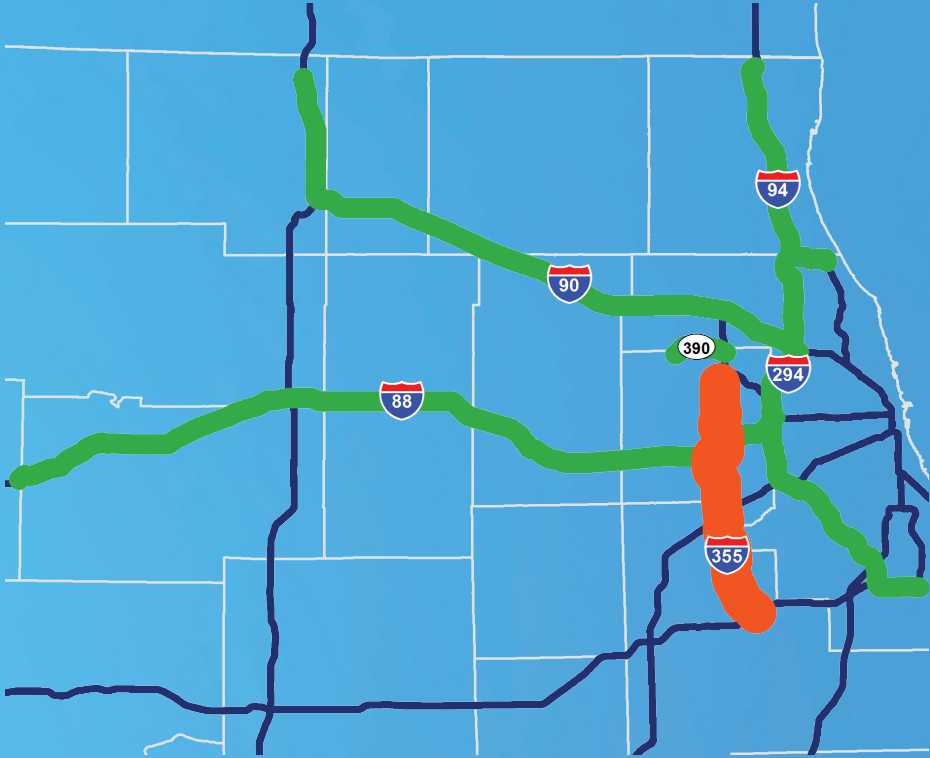



SECTION 5 Veterans Memorial Tollway

TABULATIONS TABLE

	PAGE
5-A Average Daily Traffic Volumes Between Interchanges 1980 – 2018 (Northbound)	5-4
5-B Average Daily Traffic Volumes Between Interchanges 1980 – 2018 (Southbound)	5-5
5-C General Statistics for Mainline Plazas	5-6
5-D Indexed Monthly Variation by Mainline Plaza	5-7
5-E Indexed Daily Variation by Mainline Plaza	5-7
5-F Annual Total Transactions by Toll Plaza	5-8
5-G Average Daily Traffic Data	5-9

ILLUSTRATIONS FIGURE

	PAGE
5-A Mainline Plaza Highest Hourly Volume Plaza 73 NB	5-10
5-B Mainline Plaza Highest Hourly Volume Plaza 73 SB	5-10
5-C Mainline Plaza Highest Hourly Volume Plaza 89 NB	5-10
5-D Mainline Plaza Highest Hourly Volume Plaza 89 SB	5-10
5-E Mainline Plaza Highest Hourly Volume Plaza 99 NB	5-11
5-F Mainline Plaza Highest Hourly Volume Plaza 99 SB	5-11
5-G Average Daily Traffic Trends Plaza 73 Army Trail Road	5-12
5-H Average Daily Traffic Trends Plaza 75 North Avenue	5-12
5-I Average Daily Traffic Trends Plaza 77 Roosevelt Road	5-12
5-J Average Daily Traffic Trends Plaza 79 Butterfield Road	5-13
5-K Average Daily Traffic Trends Plaza 81 Ogden Avenue	5-13
5-L Average Daily Traffic Trends Plaza 83 Maple Avenue	5-13
5-M Average Daily Traffic Trends Plaza 85 63rd Street	5-14
5-N Average Daily Traffic Trends Plaza 87 75th Street	5-14
5-O Average Daily Traffic Trends Plaza 89 Boughton Road	5-14
5-P Average Daily Traffic Trends Plaza 90 Boughton Road Ramp	5-15
5-Q Average Daily Traffic Trends Plaza 93 127th Street	5-15
5-R Average Daily Traffic Trends Plaza 95 Archer Avenue/143rd Street	5-15
5-S Average Daily Traffic Trends Plaza 97 Illinois Route 7	5-16
5-T Average Daily Traffic Trends Plaza 99 Spring Creek	5-16
5-U Average Daily Traffic Trends Plaza 101 U.S. Route 6	5-16
5-V Average Weekday Speed Distributions, Northern Section—Northbound	5-17
5-W Average Weekday Speed Distributions, Northern Section—Southbound	5-17
5-X Average Weekday Speed Distributions, Central Section—Northbound	5-17
5-Y Average Weekday Speed Distributions, Central Section—Southbound	5-17



SECTION 5 Veterans Memorial Tollway

ILLUSTRATIONS (CONTINUED) FIGURE

PAGE

5-Z	Average Weekday Speed Distributions, Southern Section—Northbound	5-18
5-AA	Average Weekday Speed Distributions, Southern Section—Southbound	5-18
5-AB	Roadway Performance Measures, Northern Section	5-19
5-AC	Roadway Performance Measures, Central Section	5-20
5-AD	Roadway Performance Measures, Southern Section	5-21
5-AE	Average Speed Contours, MP 1.5 to 29.5	5-22



This Page Is Intentionally Left Blank



TABLE 5-A: AVERAGE DAILY TRAFFIC VOLUMES BETWEEN INTERCHANGES 1980-2018 (NORTHBOUND)

Location	Mile Post	Miles Btwn. Int.	ADT 1980	Average Annual Percent Change	ADT 1990	Average Annual Percent Change	ADT 2000	Average Annual Percent Change	ADT 2010	Average Annual Percent Change	ADT 2018
Illinois Route 53 & Army Trail Road	29.8										
Toll Plaza 73	29.2	1.9	N/A	-	27,490	6.0	49,080	1.0	54,050	0.1	54,610
North Avenue (PL75)	27.9										
		3.3	N/A	-	31,630	6.0	56,870	0.6	60,470	0.0	60,640
Roosevelt Road (PL77)	24.6										
		2.0	N/A	-	29,970	6.5	56,450	0.6	60,120	0.0	60,010
Butterfield Road (PL79)	22.6										
		1.1	N/A	-	29,130	6.8	56,210	0.9	61,400	0.0	61,310
Reagan Memorial Tollway (E. Int)	21.5										
		2.0	N/A	-	15,330	6.5	28,880	2.1	35,650	0.7	37,800
Ogden Avenue (PL81)	19.5										
		0.4	N/A	-	18,180	2.8	23,900	5.0	38,930	0.2	39,480
Reagan Memorial Tollway (W. Int)	19.1										
		1.2	N/A	-	29,390	6.4	54,880	2.4	69,230	0.4	71,590
Maple Avenue (PL83)	18.3										
		1.1	N/A	-	28,390	6.2	52,010	2.5	66,260	0.6	69,550
63rd Street (PL85)	17.2										
		1.7	N/A	-	25,150	6.2	45,820	2.8	60,440	0.7	63,660
75th Street (PL87)	15.5										
Toll Plaza 89	14.4	1.7	N/A	-	20,320	6.7	38,860	3.8	56,660	0.7	60,050
Boughton Road (PL90)	13.8										
		1.5	N/A	-	16,490	7.3	33,470	4.8	53,640	1.0	58,270
I-55	12.3										
		3.4	N/A	-	N/A	-	N/A	-	33,830	1.9	39,450
127th Street (PL93)	8.9										
		1.6	N/A	-	N/A	-	N/A	-	31,670	2.1	37,520
Archer Avenue/143rd Street (PL95)	7.3										
		2.5	N/A	-	N/A	-	N/A	-	28,690	2.1	33,870
Illinois Route 7/159th Street (PL97)	4.8										
Toll Plaza 99	3.3	4.0	N/A	-	N/A	-	N/A	-	23,480	2.9	29,490
U.S. Route 6 (PL101)	0.8										
		0.8	N/A	-	N/A	-	N/A	-	18,960	3.4	24,800
I-80	0.0										

TABLE 5-B: AVERAGE DAILY TRAFFIC VOLUMES BETWEEN INTERCHANGES 1980-2018 (SOUTHBOUND)

Location	Mile Post	Miles Btwn. Int.	ADT 1980	Average Annual Percent Change	ADT 1990	Average Annual Percent Change	ADT 2000	Average Annual Percent Change	ADT 2010	Average Annual Percent Change	ADT 2018
Illinois Route 53 & Army Trail Road	29.8										
Toll Plaza 73	29.2	1.9	N/A	-	27,380	6.2	49,870	0.8	54,110	-3.1	54,500
North Avenue (PL75)	27.9										
		3.3	N/A	-	31,280	6.4	58,060	0.4	60,560	0.0	60,680
Roosevelt Road (PL77)	24.6										
		2.0	N/A	-	29,340	6.9	56,940	0.8	61,360	0.0	61,140
Butterfield Road (PL79)	22.6										
		1.1	N/A	-	28,420	7.1	56,520	0.9	61,900	0.3	63,600
Reagan Memorial Tollway (E. Int)	21.5										
		1.4	N/A	-	24,240	7.1	48,220	1.3	55,070	0.1	55,470
Reagan Memorial Tollway (W. Int)	20.1										
		0.6	N/A	-	26,770	6.8	51,540	2.0	62,870	0.8	67,030
Ogden Avenue (PL81)	19.5										
		1.2	N/A	-	29,410	6.6	55,680	2.2	69,140	0.6	72,590
Maple Avenue (PL83)	18.3										
		1.1	N/A	-	28,600	6.3	52,680	2.4	66,600	0.7	70,350
63rd Street (PL85)	17.2										
		1.7	N/A	-	25,390	6.3	46,870	2.6	60,820	0.8	64,690
75th Street (PL87)	15.5										
Toll Plaza 89	14.4	1.7	N/A	-	20,530	6.8	39,640	3.8	57,420	0.7	60,630
Boughton Road (PL90)	13.8										
		1.5	N/A	-	16,740	7.3	33,900	5.1	55,790	0.9	59,750
I-55	12.3										
		3.4	N/A	-	N/A	-	N/A	-	33,800	1.9	39,250
127th Street (PL93)	8.9										
		1.6	N/A	-	N/A	-	N/A	-	31,350	2.0	36,710
Archer Avenue/143rd Street (PL95)	7.3										
		2.5	N/A	-	N/A	-	N/A	-	28,660	1.9	33,280
Illinois Route 7/159th Street (PL97)	4.8										
Toll Plaza 99	3.3	4.0	N/A	-	N/A	-	N/A	-	23,530	2.5	28,740
U.S. Route 6 (PL101)	0.8										
		0.8	N/A	-	N/A	-	N/A	-	18,410	2.9	23,220
I-80	0.0										



**TABLE 5-C: GENERAL STATISTICS FOR MAINLINE PLAZAS
(Vehicles/Hour)**

Mainline Plaza	Dir.	30th HV	Period	Mean	Med.	Max.	Min.	Std. Dev.	85th %
73 Army Trail Road	NB	5,608	AM Peak	4,928	4,974	6,020	2,148	477	5,292
			PM Peak	4,685	4,704	5,522	2,545	395	5,038
			OFF Peak	2,047	2,195	5,168	93	1,423	3,618
			Weekend	2,012	1,947	5,681	99	1,362	3,452
			Holidays	1,775	1,727	4,878	113	1,254	3,184
	SB	5,794	AM Peak	4,212	3,960	5,912	1,812	852	5,194
			PM Peak	4,768	4,739	6,040	2,792	569	5,373
			OFF Peak	2,113	2,024	6,019	93	1,551	3,941
			Weekend	1,998	1,886	5,888	120	1,366	3,409
			Holidays	1,783	1,690	5,024	94	1,271	3,188
89 Boughton Road	NB	6,700	AM Peak	5,879	6,008	7,097	2,630	673	6,464
			PM Peak	4,293	4,294	5,465	2,303	366	4,664
			OFF Peak	2,216	2,413	5,435	134	1,497	3,821
			Weekend	2,288	2,231	6,718	136	1,508	3,841
			Holidays	2,036	2,031	6,095	151	1,386	3,546
	SB	7,261	AM Peak	3,253	3,191	4,184	1,907	503	3,839
			PM Peak	6,502	6,587	7,525	4,103	629	7,117
			OFF Peak	2,325	2,444	7,013	123	1,682	3,939
			Weekend	2,272	2,205	7,376	165	1,575	3,689
			Holidays	2,061	1,873	7,138	114	1,560	3,604
99 Spring Creek	NB	3,679	AM Peak	3,269	3,317	4,086	1,614	365	3,581
			PM Peak	2,134	2,136	2,736	1,404	191	2,320
			OFF Peak	1,076	1,119	3,079	81	738	1,816
			Weekend	1,092	1,067	3,592	72	736	1,765
			Holidays	1,003	996	3,162	56	699	1,724
	SB	3,376	AM Peak	1,796	1,732	2,435	463	333	2,155
			PM Peak	2,990	3,025	3,647	1,341	272	3,204
			OFF Peak	1,087	1,049	3,338	56	780	1,968
			Weekend	1,070	1,008	3,963	61	752	1,770
			Holidays	1,003	885	4,029	61	788	1,804

AM Peak = Weekday 6:00 AM To 8:00 AM Except Fridays
 PM Peak = Weekday 4:00 PM To 6:00 PM Except Fridays
 OFF Peak = Weekdays Except Fridays and AM and PM Peak Periods
 Weekend = Fridays, Saturdays, and Sundays
 Holidays = See Page 1-6 for a list of Holidays.



TABLE 5-D: INDEXED MONTHLY VARIATION BY MAINLINE PLAZA

Month	Army Trail Road	Boughton Road	Spring Creek
January	0.93	0.92	0.87
February	0.97	0.96	0.91
March	1.05	1.04	0.98
April	1.08	1.06	1.00
May	1.08	1.10	1.08
June	1.06	1.10	1.10
July	1.01	1.03	1.05
August	1.00	1.00	1.06
September	0.95	0.93	1.01
October	1.02	0.99	1.04
November	0.94	0.95	0.98
December	0.91	0.92	0.93

TABLE 5-E: INDEXED DAILY VARIATION BY MAINLINE PLAZA

Month	Day	Army Trail Road	Boughton Road	Spring Creek
August	Monday	1.01	1.01	1.07
	Tuesday	0.96	0.97	1.03
	Wednesday	0.97	0.99	1.04
	Thursday	0.97	0.99	1.03
	Friday	0.98	0.99	1.04
	Saturday	0.99	0.96	1.07
	Sunday	1.02	0.99	1.05
December	Monday	0.90	0.92	0.92
	Tuesday	0.90	0.89	0.93
	Wednesday	0.94	0.94	0.96
	Thursday	0.94	0.95	0.95
	Friday	0.95	0.96	0.97
	Saturday	0.91	0.95	0.97
	Sunday	0.90	0.91	0.92

Table 5-E includes Monthly Variation

TABLE 5-F: ANNUAL TOTAL TRANSACTIONS BY TOLL PLAZA

Plaza	Plaza Code*	2017	2018	Percentage Change
73 Army Trail Road	M	42,583,623	39,822,404	-6.5%
75 North Avenue	R	11,015,700	10,068,880	-8.6%
77 Roosevelt Road	R	6,123,265	5,316,821	-13.2%
79 Butterfield Road	R	6,449,502	6,252,934	-3.0%
81 Ogden Avenue	R	1,800,854	1,874,922	4.1%
83 Maple Avenue	R	4,536,810	4,022,520	-11.3%
85 63rd Street	R	6,276,484	5,692,649	-9.3%
87 75th Street	R	6,095,240	5,559,165	-8.8%
89 Boughton Mainline	M	47,240,350	44,050,923	-6.8%
90 Boughton Road	R	4,765,120	4,683,102	-1.7%
93 127th Street	R	2,679,308	2,611,192	-2.5%
95 Archer Avenue	R	3,997,240	3,864,732	-3.3%
97 Route 7	R	4,873,762	4,710,235	-3.4%
99 Spring Creek	M	21,887,197	21,255,636	-2.9%
101 U.S. Route 6	R	1,843,071	1,806,886	-2.0%
Veterans Memorial Total		172,167,526	161,593,001	-6.1%

* M=Mainline / R=Ramp / A=Attended Ramp Plaza / E=Electronic Toll Collection Only Ramp
 1=Toll Collected in One Direction Only

TABLE 5-G: AVERAGE DAILY TRAFFIC DATA

Year	Average Daily Total			Average Trip
	Vehicles	Vehicle Miles	Transactions	Length (Miles)
1989	1,718	18,733	2,794	10.90
1990	116,106	913,325	148,394	7.87
1991	112,664	1,080,313	177,384	9.59
1992	125,446	1,203,491	198,723	9.59
1993	133,101	1,280,823	211,525	9.62
1994	135,381	1,297,315	214,764	9.58
1995	136,250	1,324,254	219,397	9.72
1996	140,780	1,397,726	230,871	9.93
1997	149,430	1,481,389	240,479	9.91
1998	153,670	1,524,455	253,551	9.92
1999	162,950	1,578,153	267,579	9.68
2000	174,040	1,712,671	281,509	9.84
2001	184,280	1,820,705	297,086	9.88
2002	192,155	1,916,090	313,813	9.97
2003	193,150	1,940,636	316,557	10.05
2004	202,630	2,006,635	329,275	9.90
2005	199,310	1,953,866	321,209	9.80
2006	205,210	1,972,819	327,759	9.61
2007	212,000	2,007,320	335,879	9.47
2008	248,120	2,705,470	418,865	10.90
2009	251,180	2,783,566	428,534	11.08
2010	246,290	2,740,256	425,576	11.13
2011	253,630	2,845,902	442,475	11.22
2012	245,530	2,767,855	425,669	11.27
2013	257,920	2,778,398	426,939	10.77
2014	260,710	2,863,237	435,932	10.98
2015	276,290	3,010,917	455,847	10.90
2016	279,120	3,089,715	463,351	11.07
2017	281,970	3,159,311	471,692	11.20
2018	268,410	2,949,480	442,721	10.99

The South Extension to the Veterans Memorial Tollway opened in 2007.



FIGURE 5-B

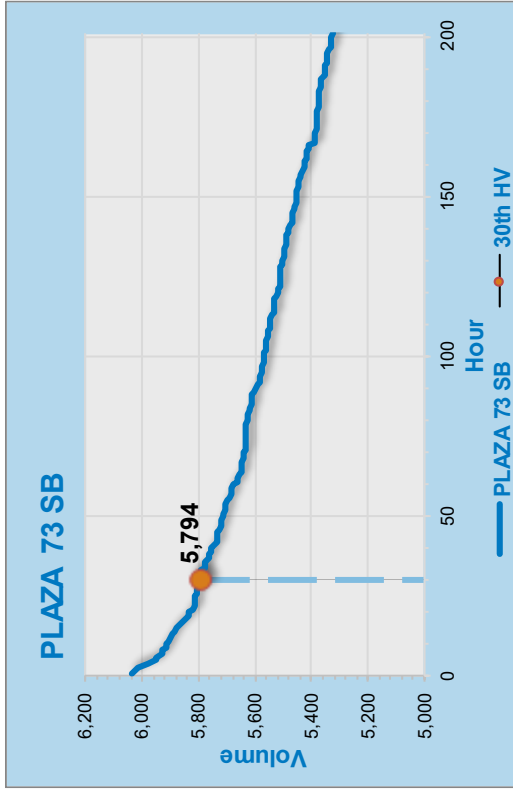

FIGURE 5-D

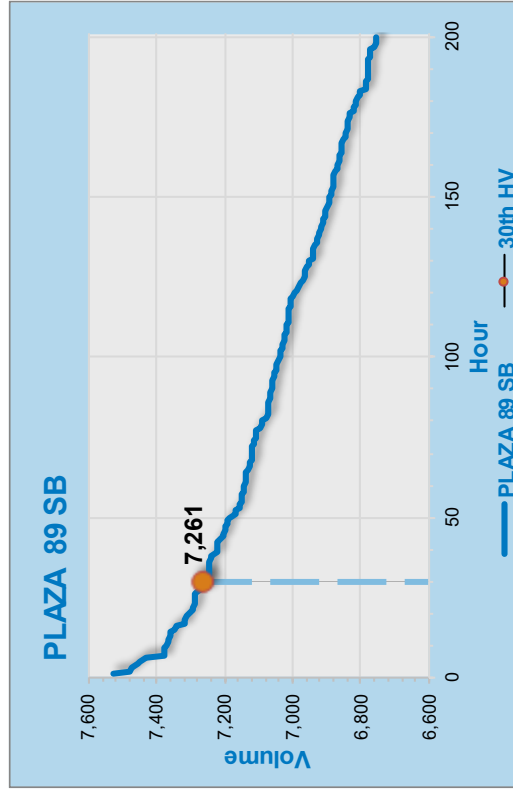

FIGURE 5-A

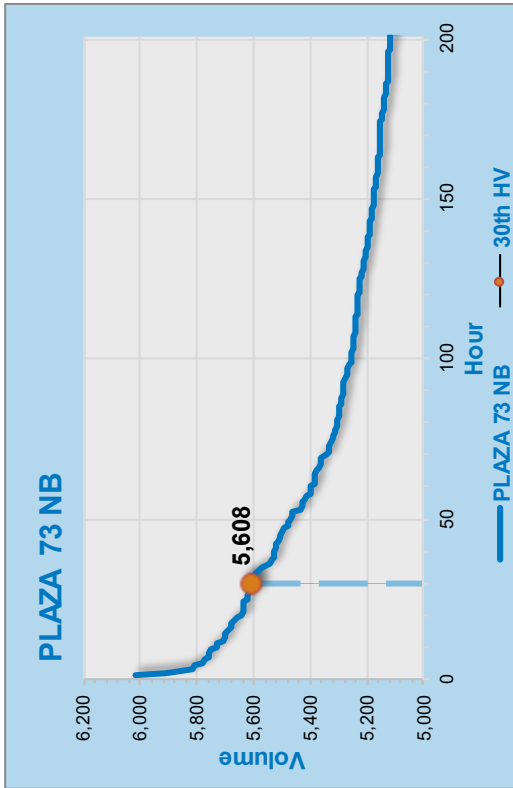
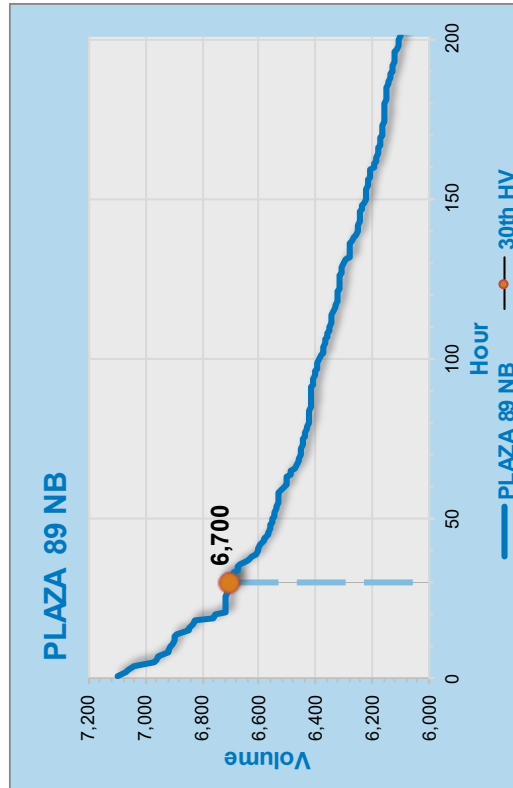

FIGURE 5-C



MAINLINE PLAZA HIGHEST HOURLY VOLUME



FIGURE 5-F

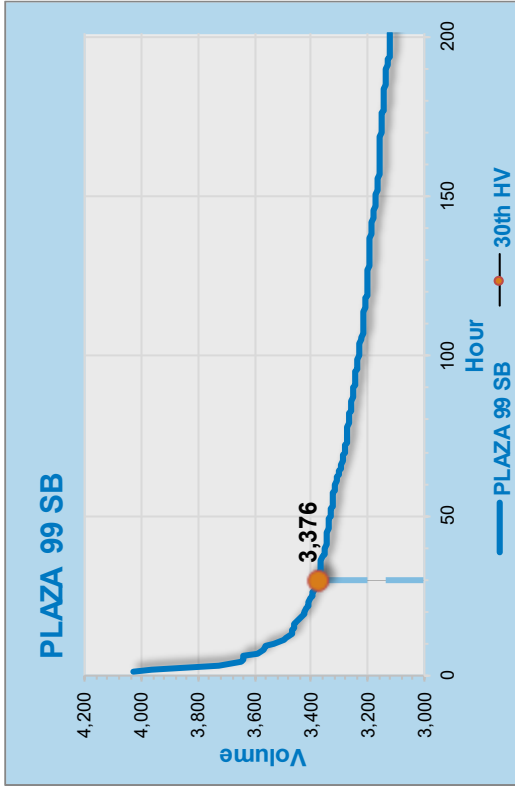
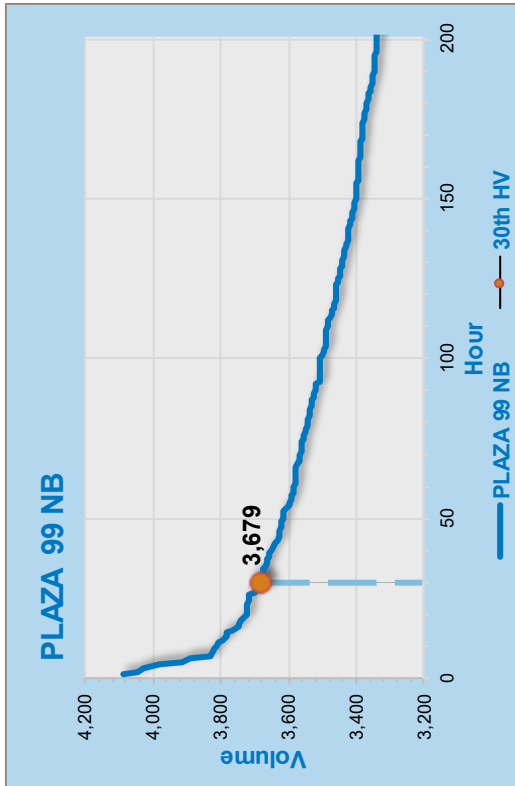

FIGURE 5-E



MAINLINE PLAZA HIGHEST HOURLY VOLUME

FIGURE 5-G

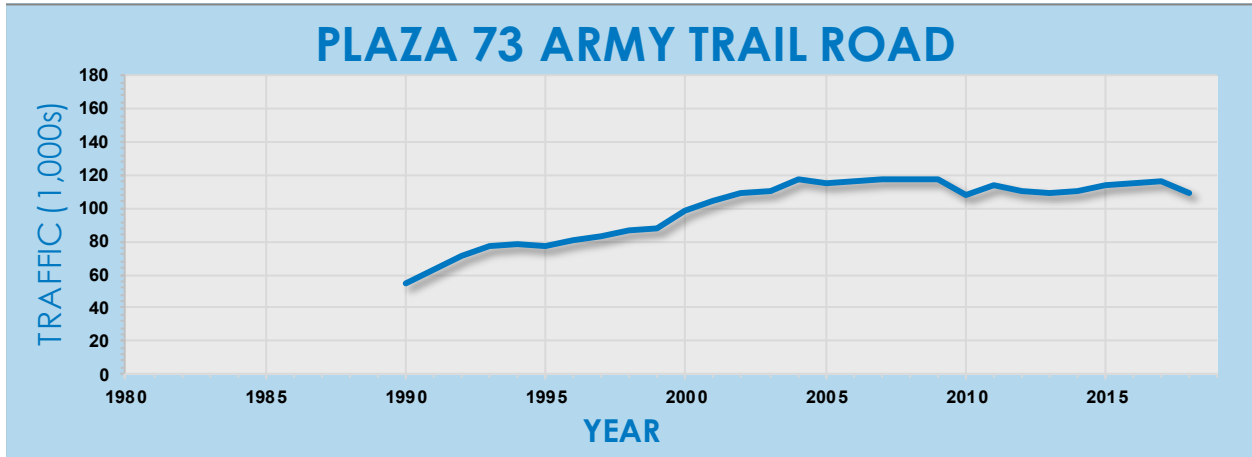

FIGURE 5-H

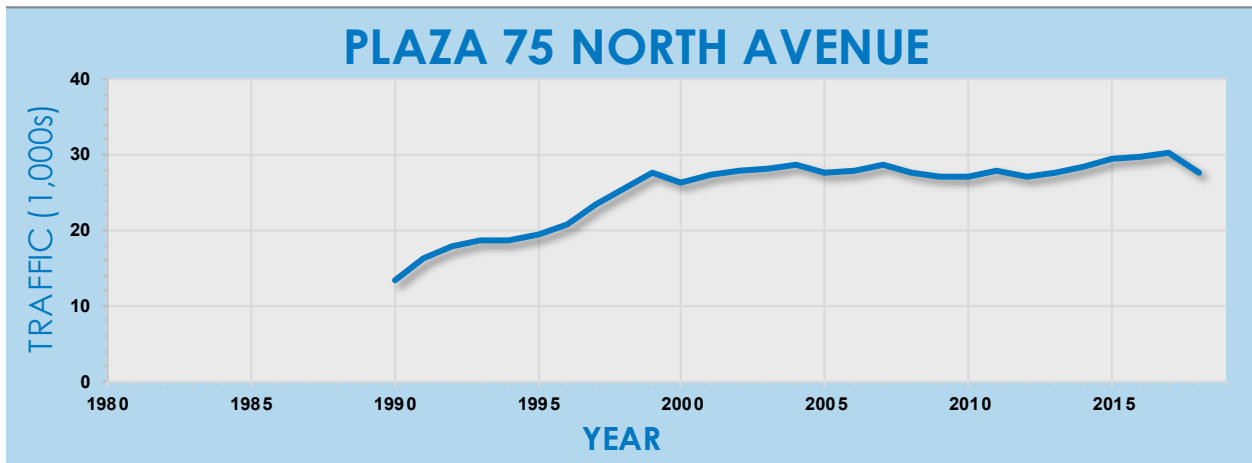
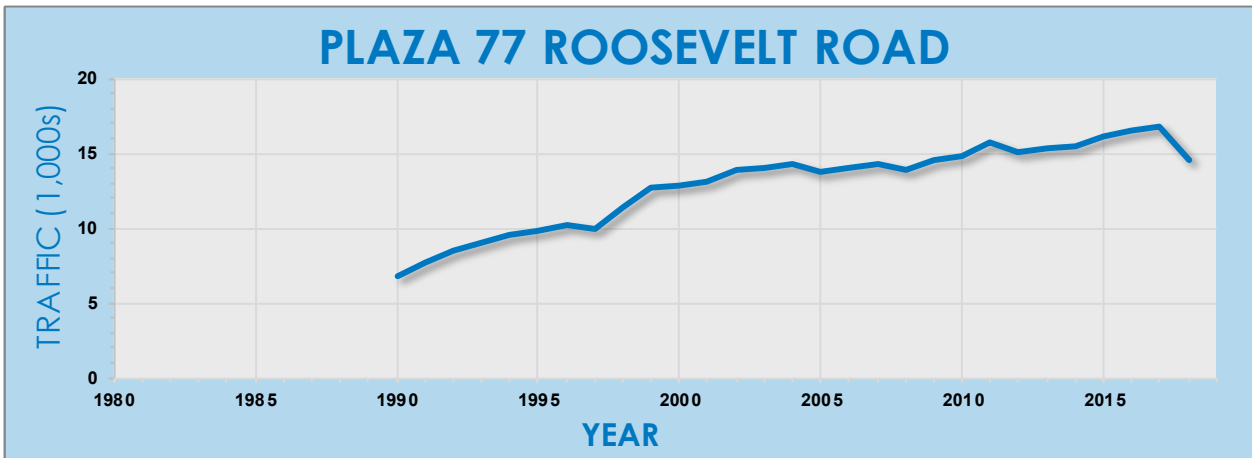

FIGURE 5-I



AVERAGE DAILY TRAFFIC TRENDS

FIGURE 5-J

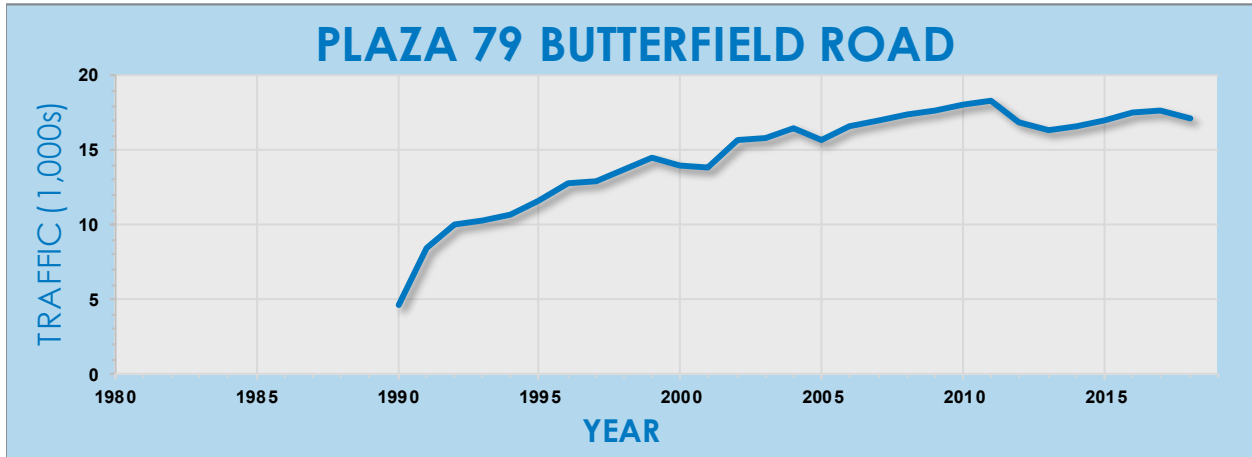

FIGURE 5-K

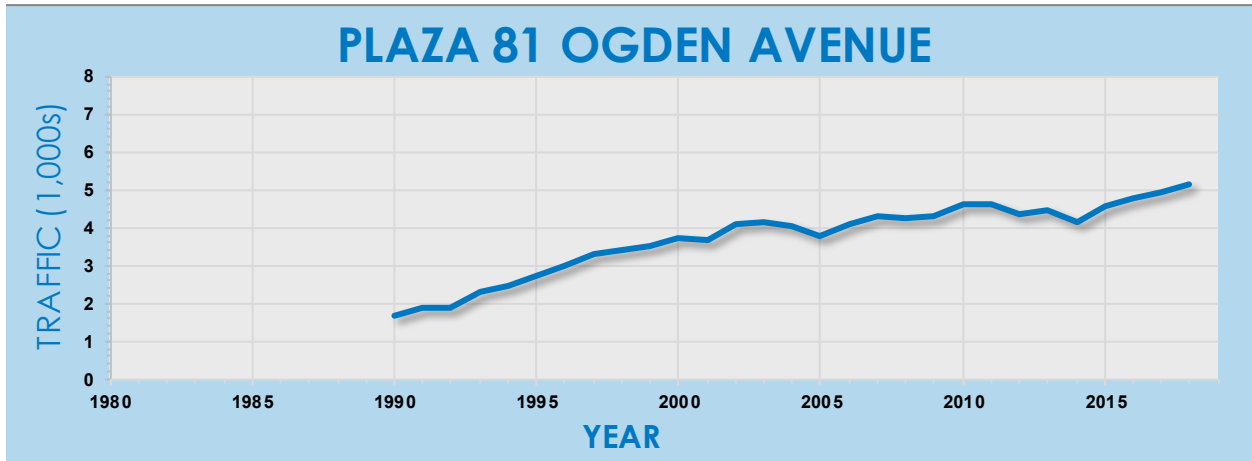
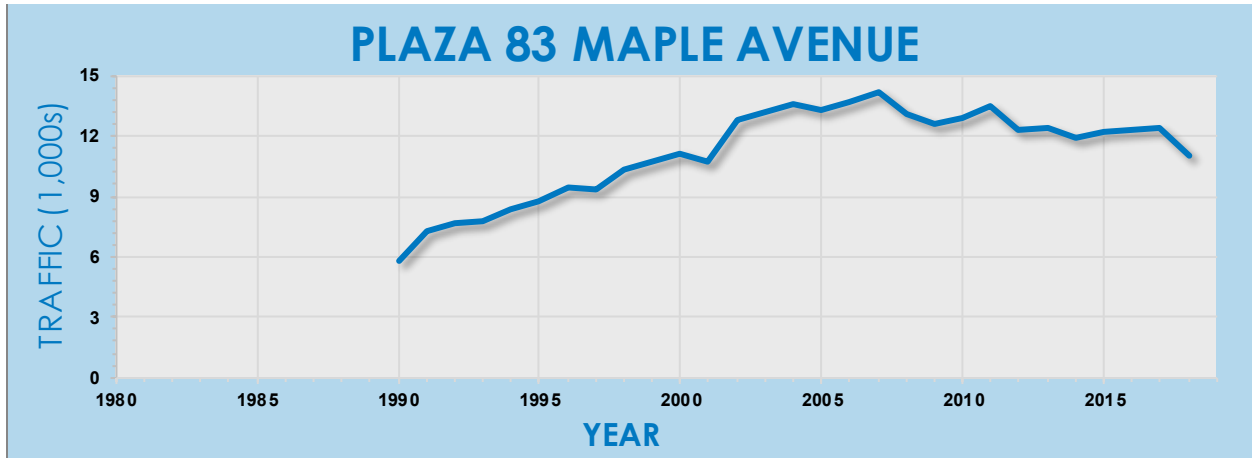

FIGURE 5-L



AVERAGE DAILY TRAFFIC TRENDS

FIGURE 5-M

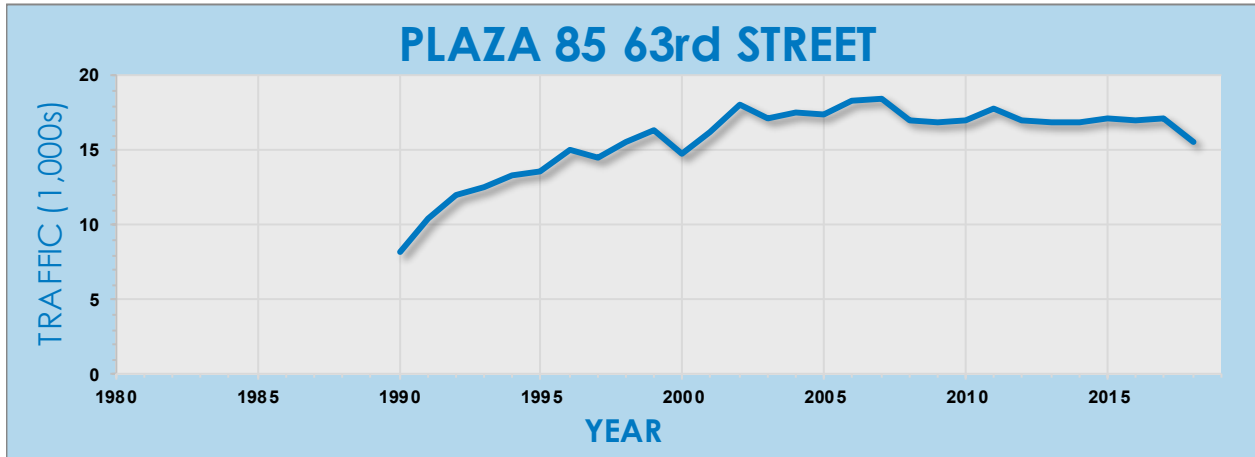

FIGURE 5-N

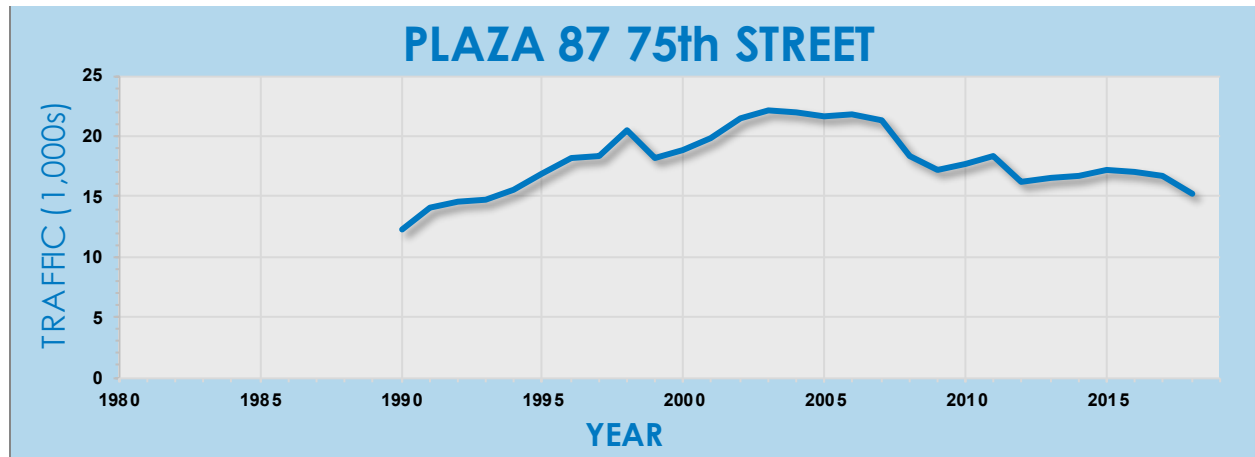
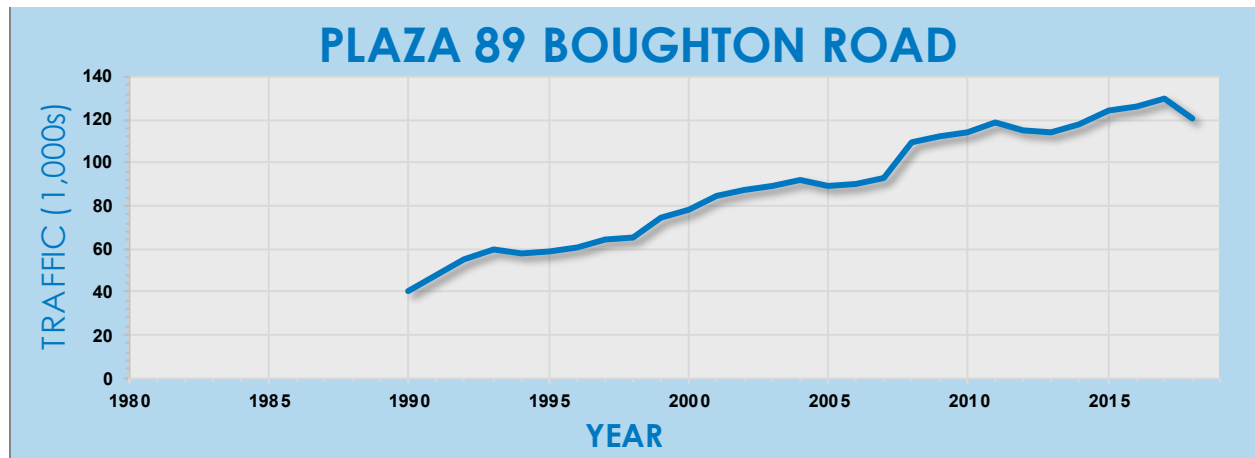

FIGURE 5-O



AVERAGE DAILY TRAFFIC TRENDS

FIGURE 5-P

Plaza 90 opened in 1999.

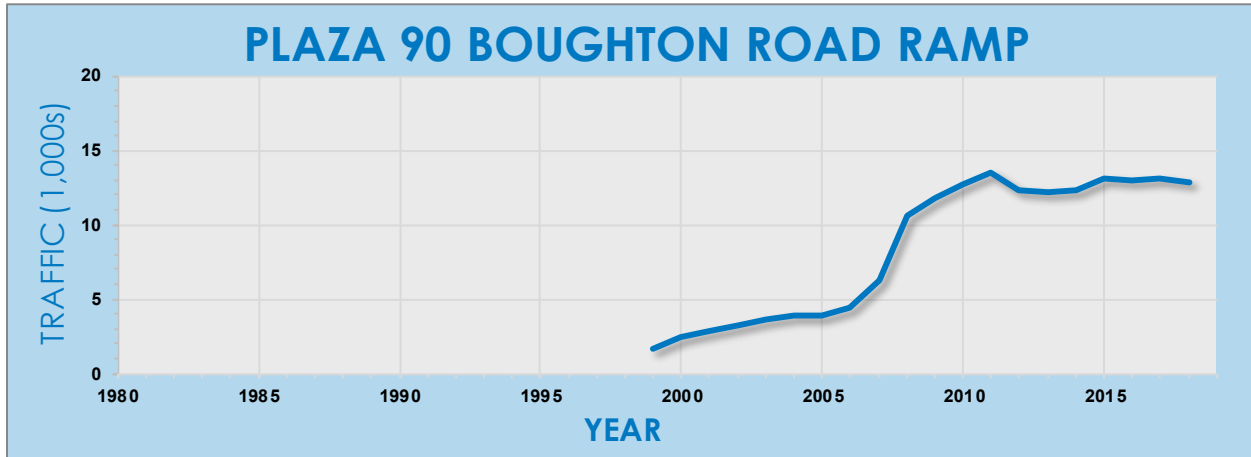

FIGURE 5-Q

The South Extension opened in 2007.

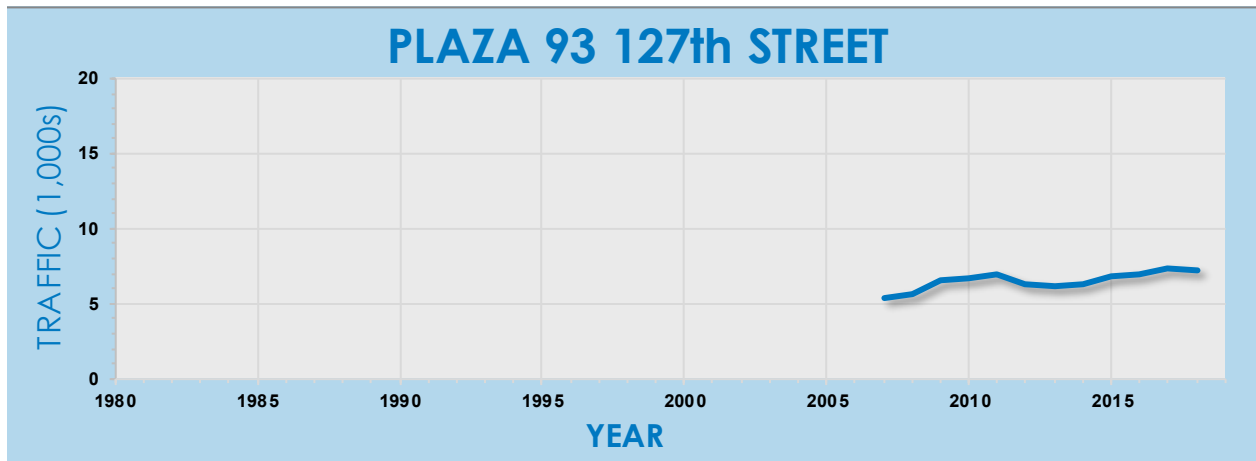
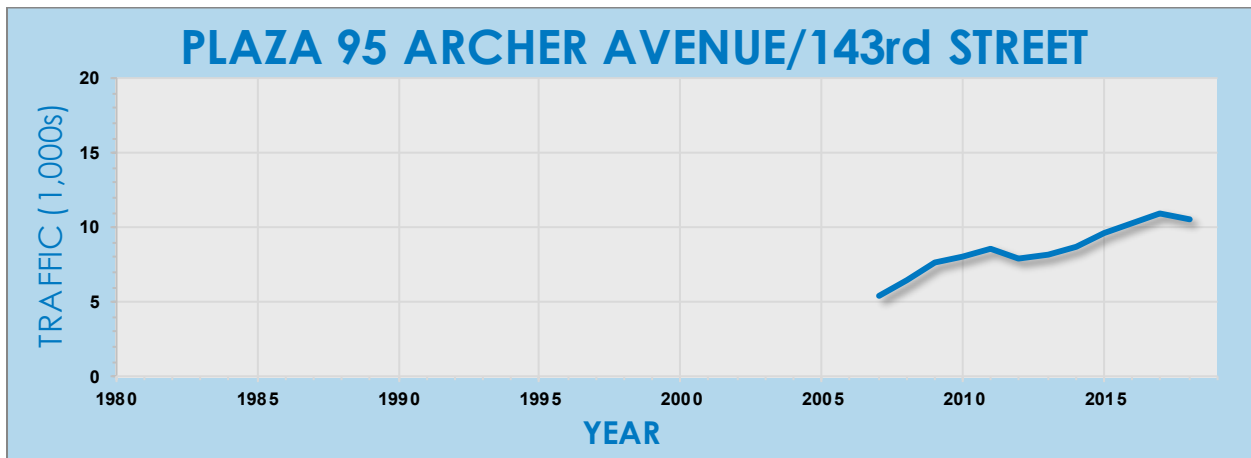

FIGURE 5-R

The South Extension opened in 2007.



AVERAGE DAILY TRAFFIC TRENDS



FIGURE 5-S

The South Extension opened in 2007.

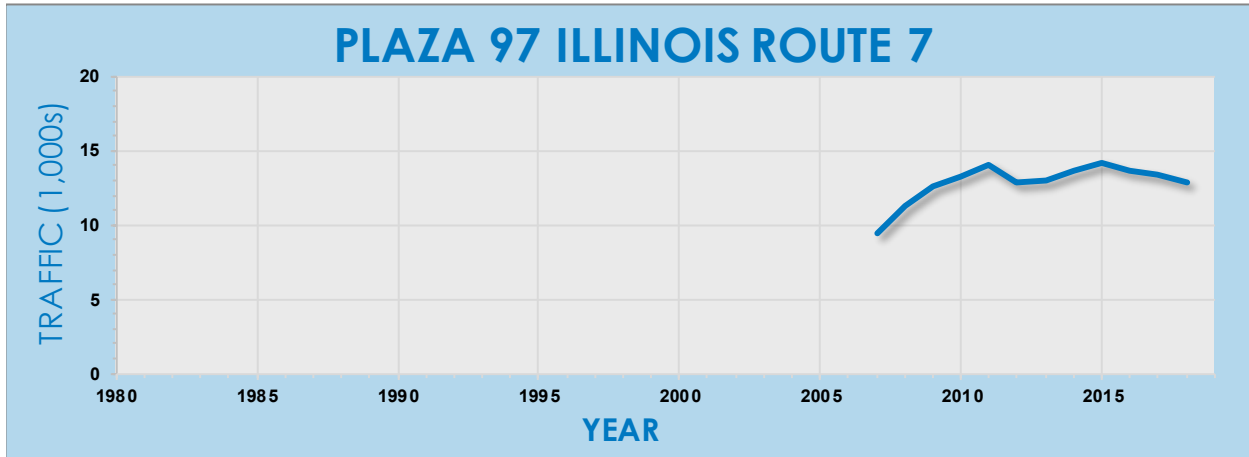

FIGURE 5-T

The South Extension opened in 2007.

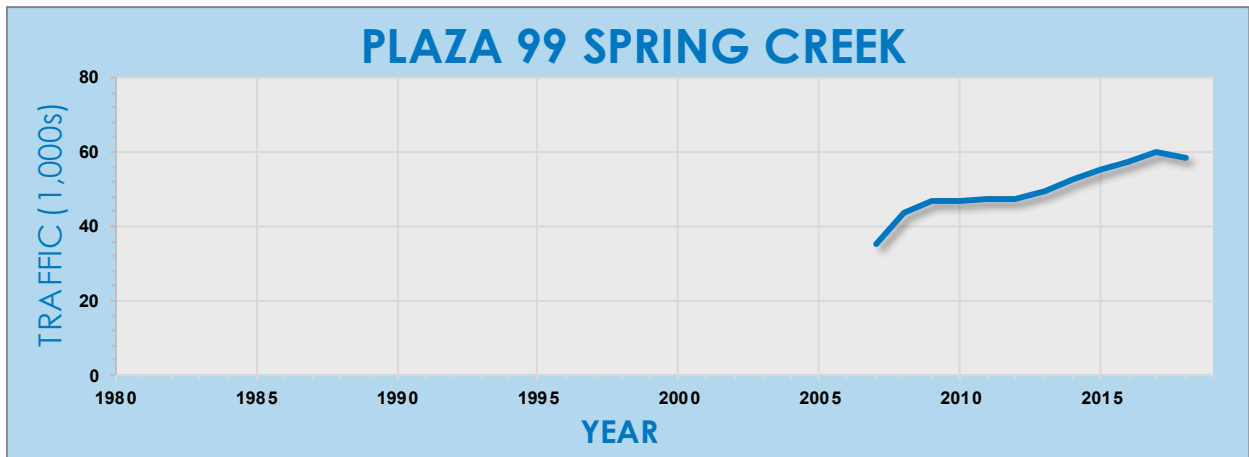
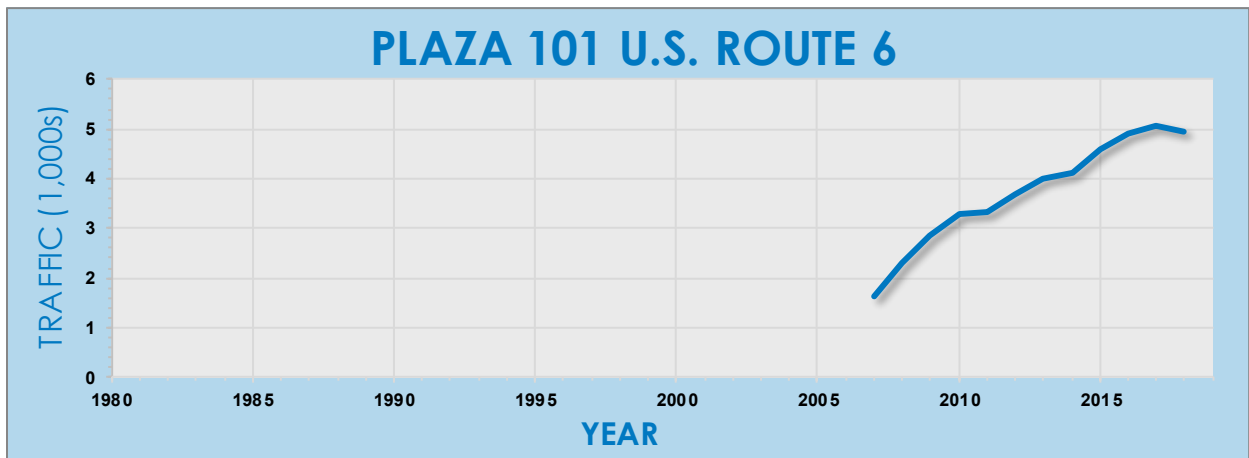

FIGURE 5-U

The South Extension opened in 2007.



AVERAGE DAILY TRAFFIC TRENDS

AVERAGE WEEKDAY SPEED DISTRIBUTIONS, NORTHERN SECTION

FIGURE 5-V

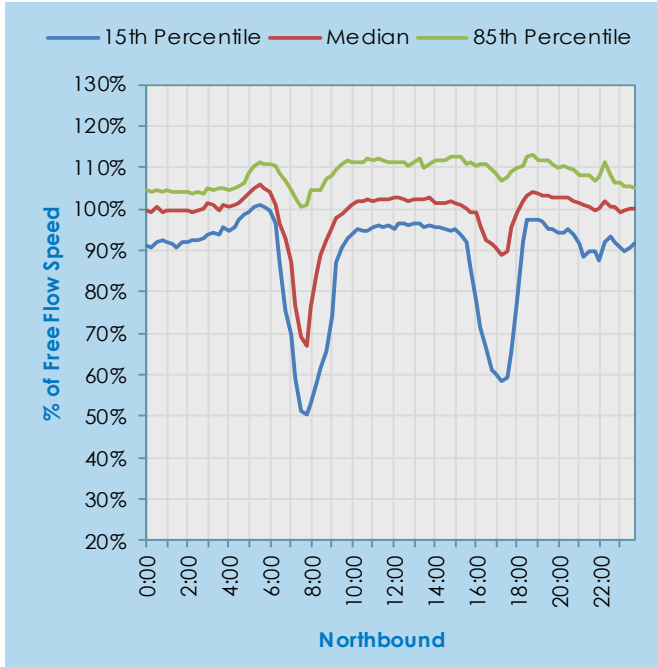
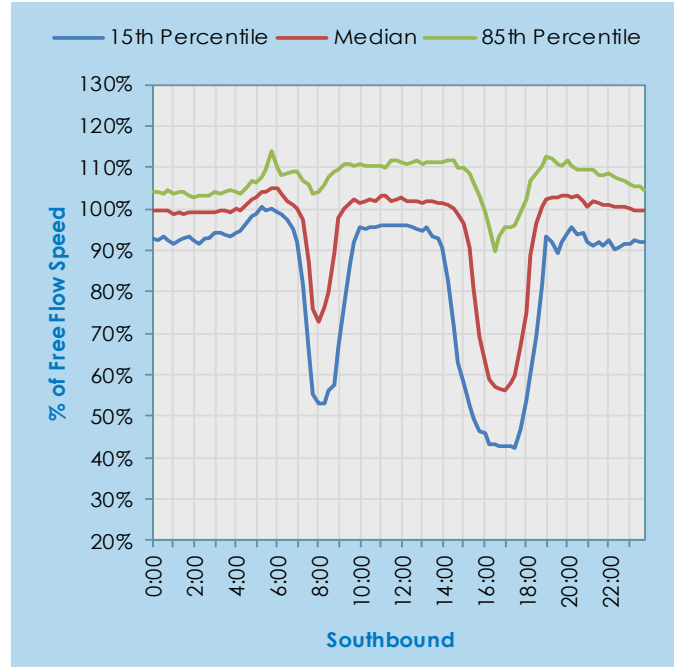

FIGURE 5-W



AVERAGE WEEKDAY SPEED DISTRIBUTIONS, CENTRAL SECTION

FIGURE 5-X

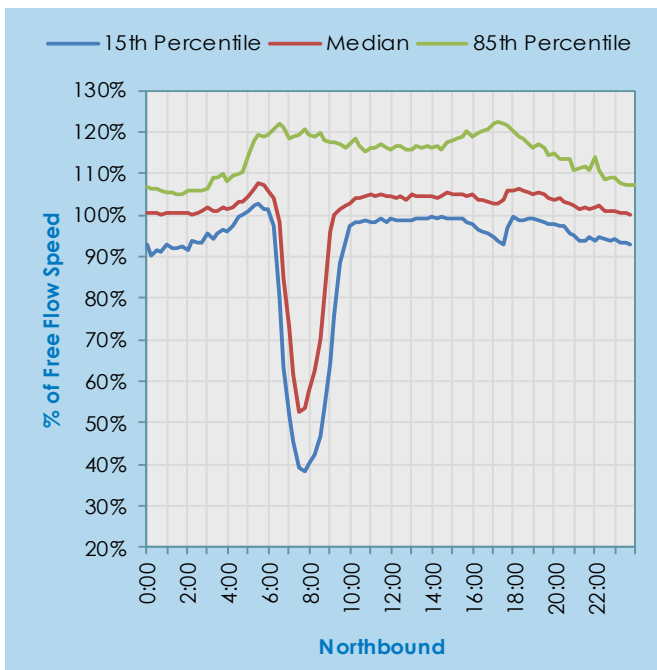
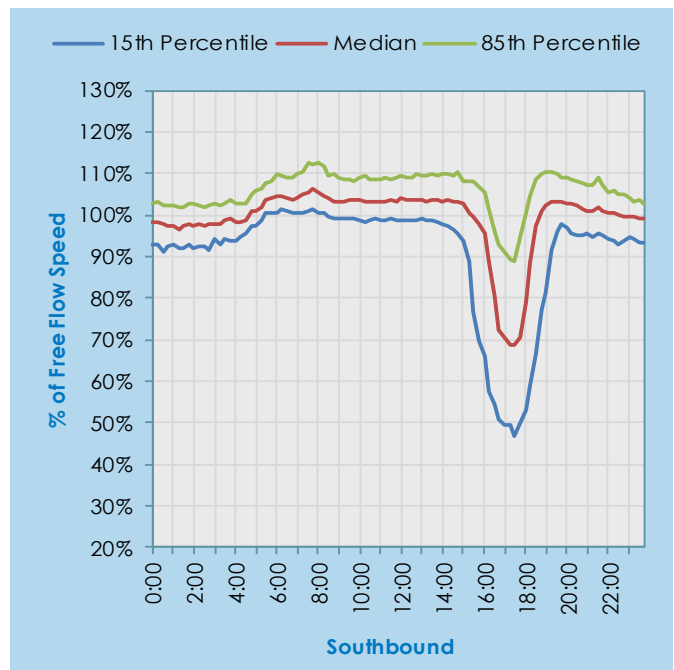

FIGURE 5-Y



AVERAGE WEEKDAY SPEED DISTRIBUTIONS, SOUTHERN SECTION

FIGURE 5-Z

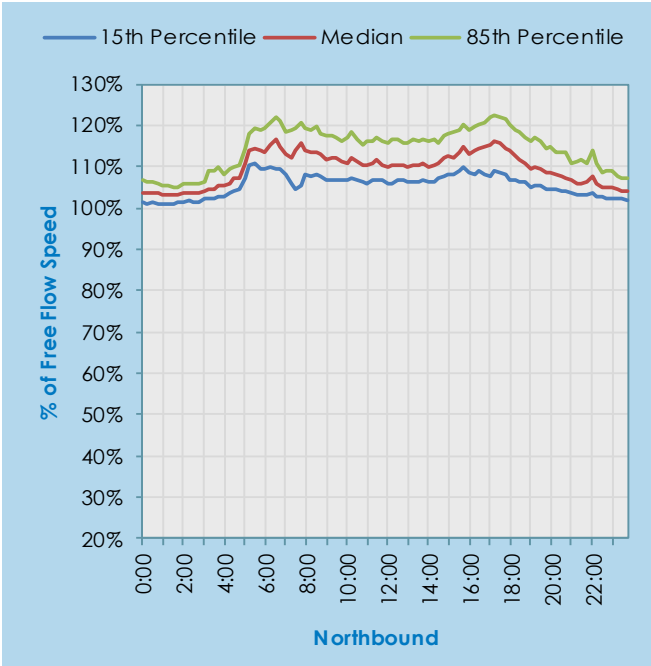
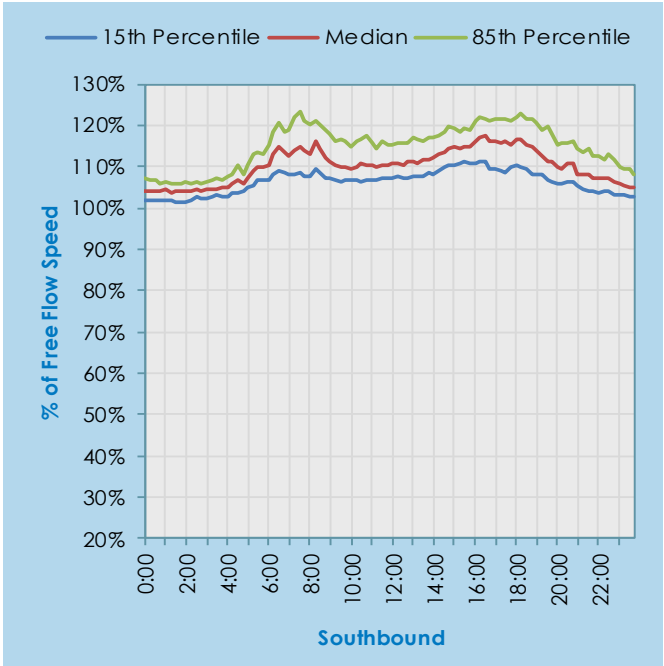
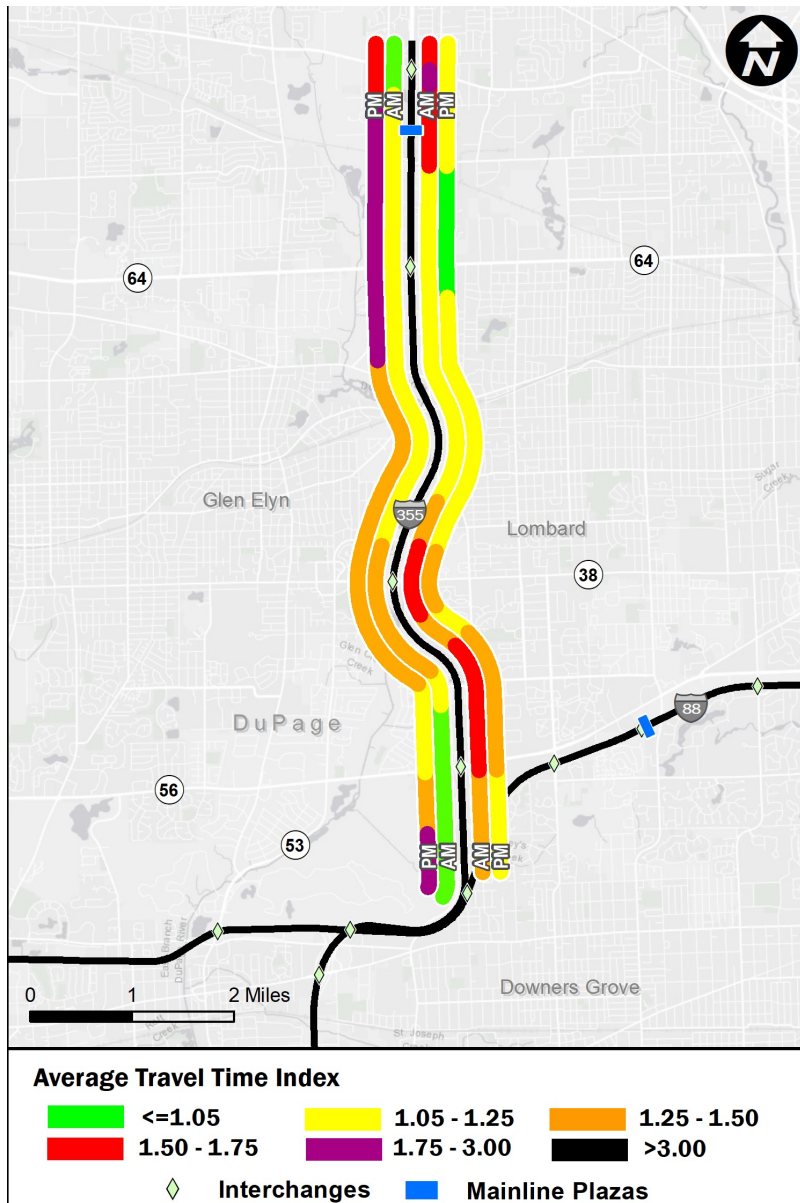

FIGURE 5-AA





Quarter	Range	Average Speed (mph)		Average Travel Time Index		Planning Time Index		Total Delay (veh-hrs / 1000 VMT)		Average Daily Delay (veh-hrs)		Percent Congested Travel	
		AM	PM	AM	PM	AM	PM	AM	PM	AM	PM	AM	PM
1	January-March	58	44	1.04	1.36	1.29	1.67	1.5	6.1	315	1,225	26	84
2	April-June	55	39	1.10	1.54	1.40	1.96	2.5	9.1	509	1,787	32	87
3	July-September	50	51	1.20	1.19	1.55	1.44	3.8	3.2	842	633	55	68
4	October-December	42	46	1.43	1.30	1.90	1.59	7.6	5.1	1,618	1,027	67	79
Total	2018 Entire Year	51	45	1.19	1.35	1.53	1.67	3.8	5.9	821	1,168	45	80

Data source: INRIX. Roadway performance measures sections and terms are defined on pages 1-4 and 1-5.

FIGURE 5-AB: ROADWAY PERFORMANCE MEASURES—NORTHERN SECTION

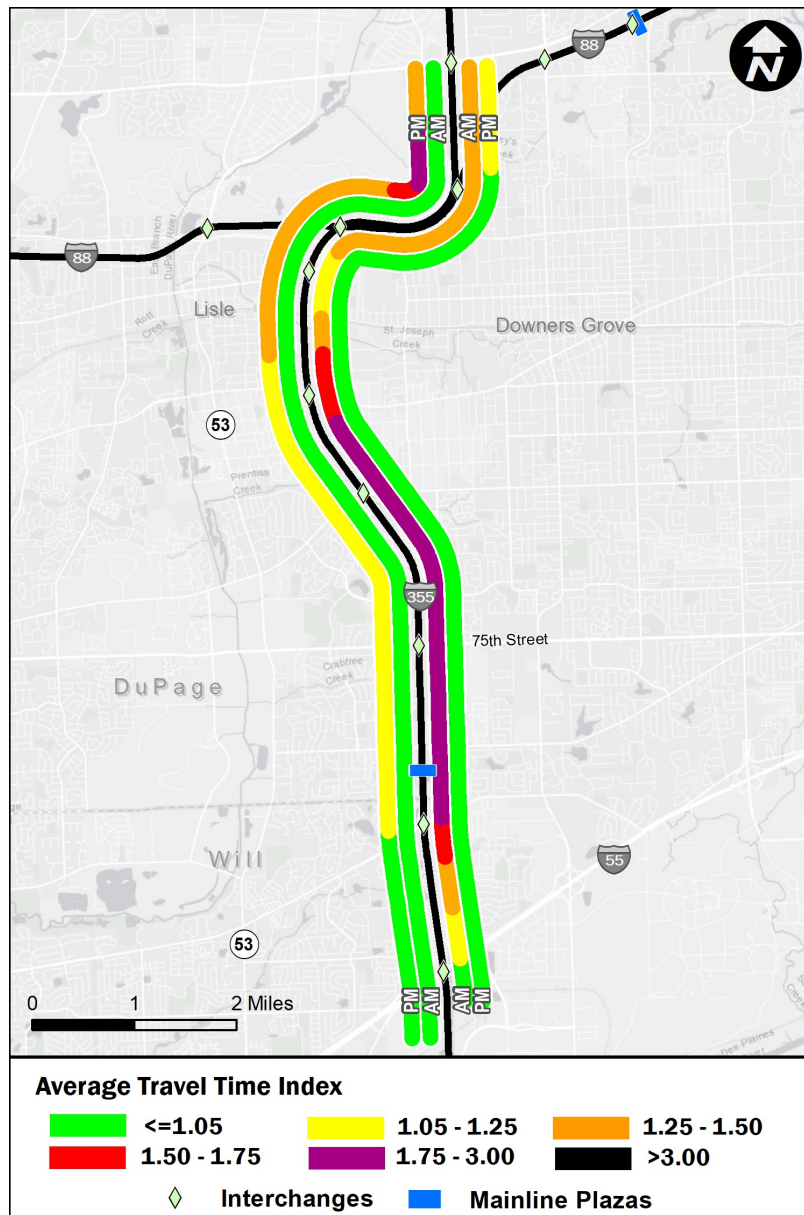

Quarter	Range	Average Speed (mph)		Average Travel Time Index		Planning Time Index		Total Delay (veh-hrs / 1000 VMT)		Average Daily Delay (veh-hrs)		Percent Congested Travel	
		AM	PM	AM	PM	AM	PM	AM	PM	AM	PM	AM	PM
1	January-March	52	46	1.16	1.30	1.71	1.52	3.6	5.4	926	1,316	31	50
2	April-June	56	46	1.07	1.32	1.23	1.67	2.0	5.6	569	1,488	32	62
3	July-September	50	47	1.20	1.27	1.42	1.47	4.3	4.9	1,177	1,134	35	50
4	October-December	52	55	1.15	1.09	1.68	1.30	3.4	1.7	1,010	460	36	58
Total	2018 Entire Year	53	48	1.14	1.25	1.51	1.49	3.3	4.4	921	1,099	33	55

Data source: INRIX. Roadway performance measures sections and terms are defined on pages 1-4 and 1-5.

FIGURE 5-AC: ROADWAY PERFORMANCE MEASURES—CENTRAL SECTION

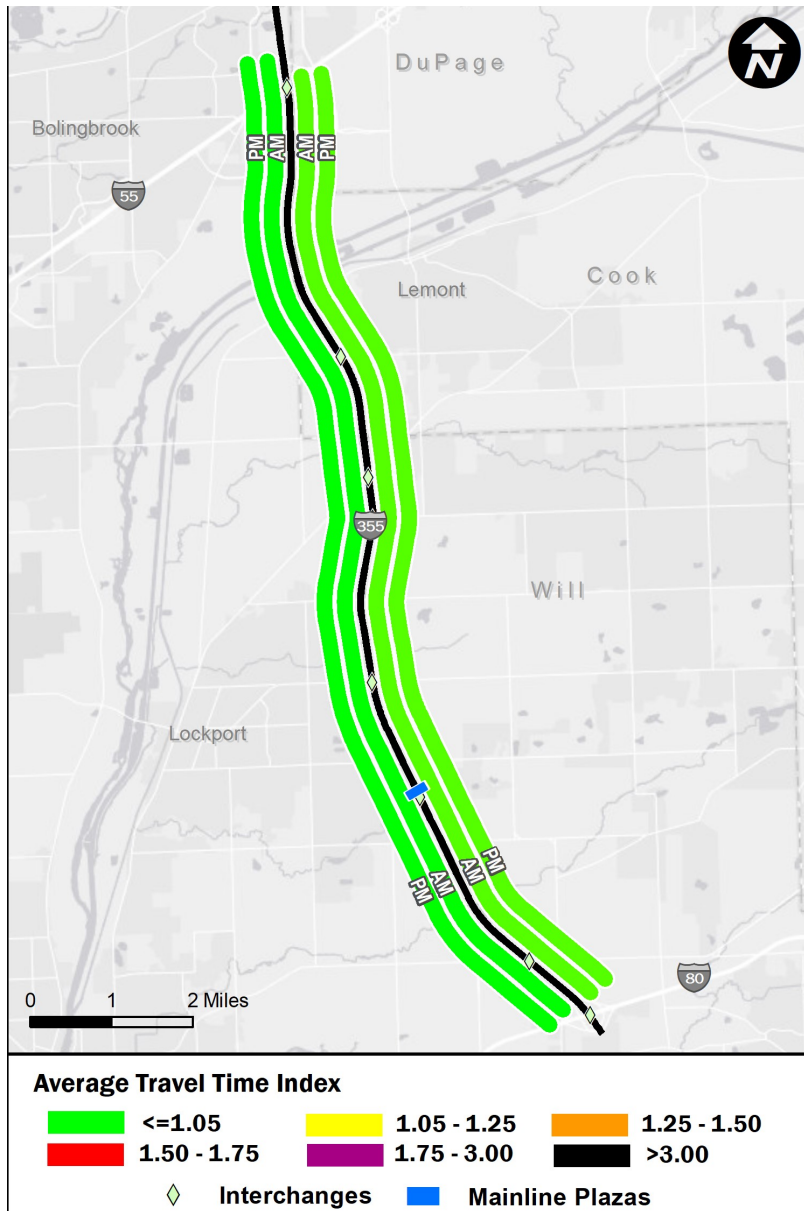

Quarter	Range	Average Speed (mph)		Average Travel Time Index		Planning Time Index		Total Delay (veh-hrs / 1000 VMT)		Average Daily Delay (veh-hrs)		Percent Congested Travel	
		AM	PM	AM	PM	AM	PM	AM	PM	AM	PM	AM	PM
1	January-March	66	71	0.91	0.85	1.07	0.88	0.2	0.0	43	2	5	1
2	April-June	67	71	0.89	0.85	0.93	0.88	0.1	0.0	18	4	2	1
3	July-September	68	67	0.88	0.90	0.92	0.95	0.1	0.1	17	19	2	3
4	October-December	70	68	0.86	0.89	0.89	0.92	0.0	0.0	10	1	0	1
Total	2018 Entire Year	68	69	0.88	0.87	0.95	0.91	0.1	0.0	22	6	2	1

Data source: INRIX. Roadway performance measures sections and terms are defined on pages 1-4 and 1-5.

FIGURE 5-AD: ROADWAY PERFORMANCE MEASURES—SOUTHERN SECTION

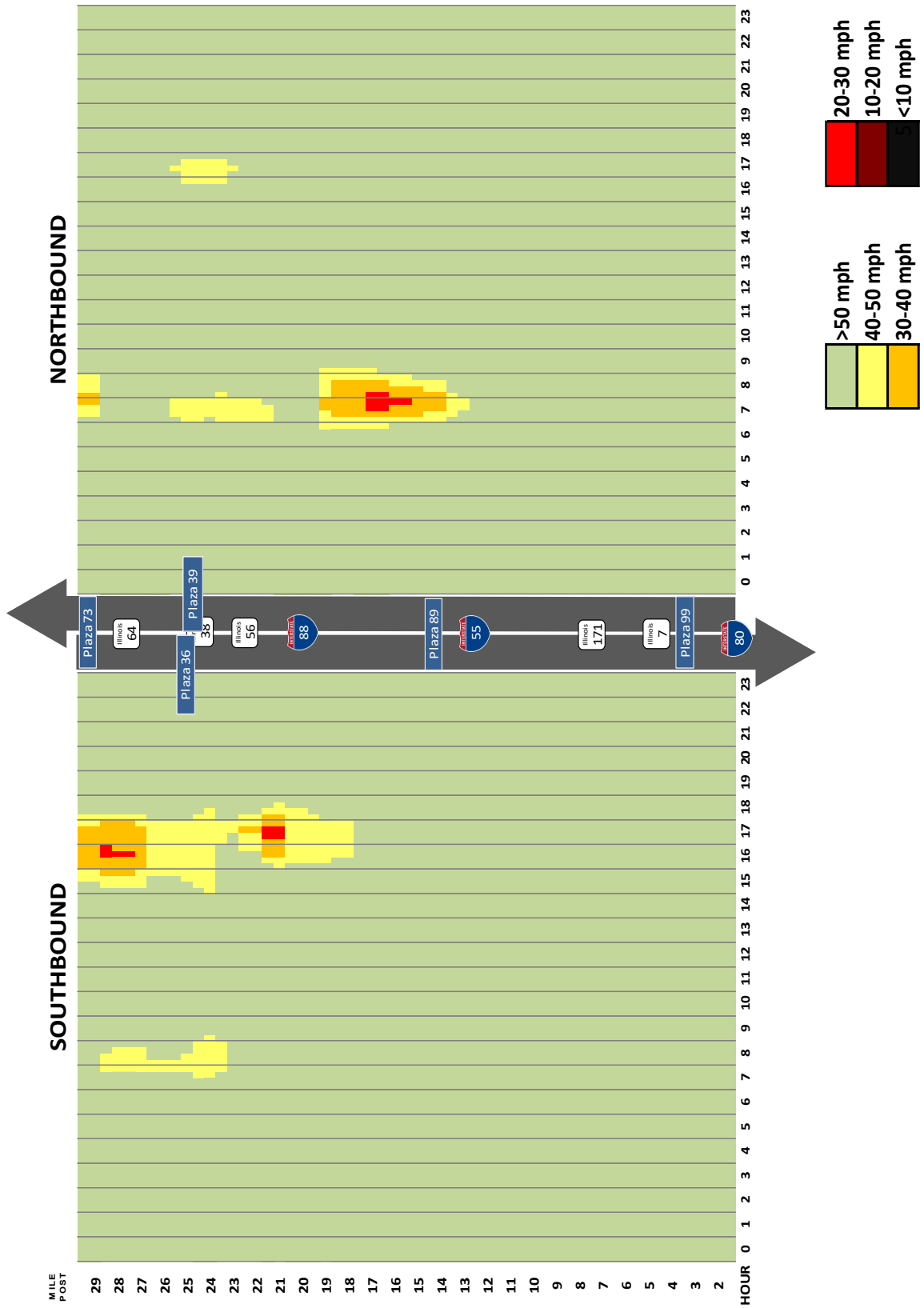
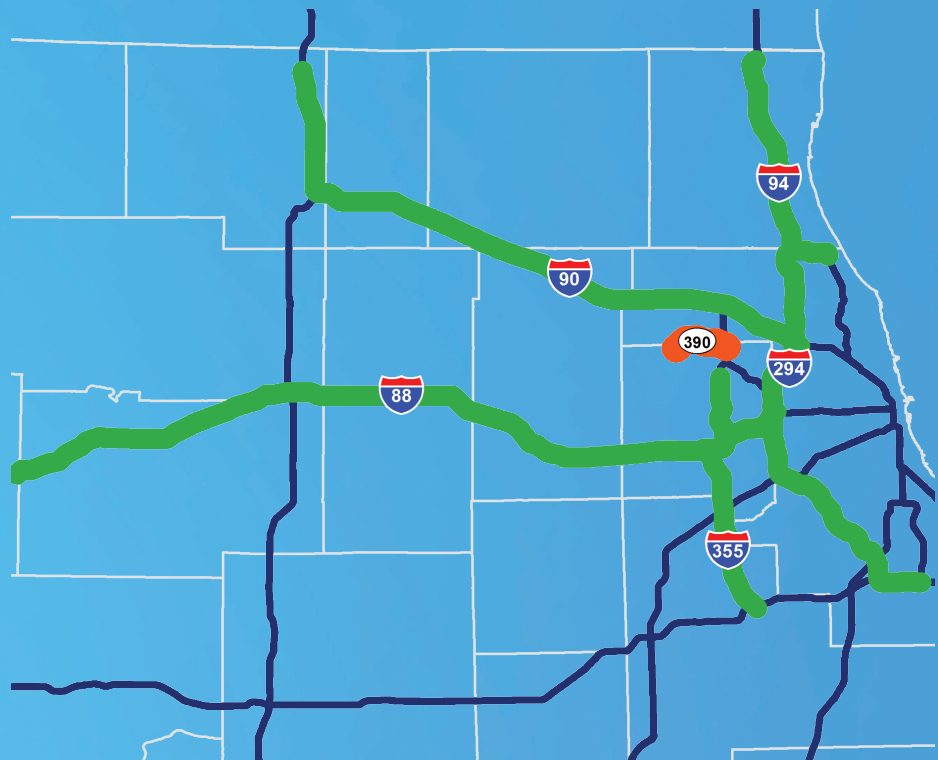

FIGURE 5-AE: AVERAGE SPEED CONTOURS, MP 1.5 TO 29.5

Illinois Route 390 Tollway





SECTION 6 Illinois Route 390 Tollway

TABULATIONS TABLE

	PAGE
6-A Average Daily Traffic Volumes Between Interchanges 2016-2018 (Westbound)	6-2
6-B Average Daily Traffic Volumes Between Interchanges 2016-2018 (Eastbound)	6-3
6-C General Statistics for Mainline Plazas	6-4
6-D Indexed Monthly Variations by Mainline Plaza	6-6
6-E Indexed Daily Variation by Mainline Plaza	6-6
6-F Annual Total Transactions by Toll Plaza	6-7
6-G Average Daily Traffic Data	6-7

ILLUSTRATIONS FIGURE

	PAGE
6-A Mainline Plaza Highest Hourly Volume Plaza 320 EB	6-8
6-B Mainline Plaza Highest Hourly Volume Plaza 320 WB	6-8
6-C Mainline Plaza Highest Hourly Volume Plaza 322 EB	6-8
6-D Mainline Plaza Highest Hourly Volume Plaza 322 WB	6-8
6-E Mainline Plaza Highest Hourly Volume Plaza 324 EB	6-9
6-F Mainline Plaza Highest Hourly Volume Plaza 324 WB	6-9
6-G Mainline Plaza Highest Hourly Volume Plaza 326 EB	6-9
6-H Mainline Plaza Highest Hourly Volume Plaza 326 WB	6-9
6-I Mainline Plaza Highest Hourly Volume Plaza 328 EB	6-10
6-J Mainline Plaza Highest Hourly Volume Plaza 328 WB	6-10
6-K Mainline Plaza Highest Hourly Volume Plaza 330 EB	6-10
6-L Mainline Plaza Highest Hourly Volume Plaza 330 WB	6-10
6-M Average Daily Traffic Trends Plaza 320 Lively Boulevard	6-11
6-N Average Daily Traffic Trends Plaza 322 Mittel Drive	6-11
6-O Average Daily Traffic Trends Plaza 324 Hamilton Lakes Boulevard	6-11
6-P Average Daily Traffic Trends Plaza 325 Ketter Road	6-12
6-Q Average Daily Traffic Trends Plaza 326 Plum Grove Road	6-12
6-R Average Daily Traffic Trends Plaza 328 Mitchell Boulevard	6-12
6-S Average Daily Traffic Trends Plaza 330 Lake Street	6-13
6-T Average Weekday Speed Distributions, Western Section—Eastbound	6-14
6-U Average Weekday Speed Distributions, Western Section—Westbound	6-14
6-V Average Weekday Speed Distributions, Eastern Section—Eastbound	6-14
6-W Average Weekday Speed Distributions, Eastern Section—Westbound	6-14
6-X Roadway Performance Measures, Western Section	6-15
6-Y Average Speed Contours, MP 5.9 to 12.5	6-16

TABLE 6-A: AVERAGE DAILY TRAFFIC VOLUMES BETWEEN INTERCHANGES 2016-2018 (WESTBOUND)

Location	Mile Post	Miles Btwn. Int.	ADT 2016	Average Annual Percent Change	ADT 2017	Average Annual Percent Change	ADT 2018
Busse Rd (IL 83)	15.8						
Toll Plaza 320		1.0			4,680		6,620
Wood Dale Road	14.8						
Toll Plaza 322		1.0			9,260		11,510
Prospect Ave	13.8						
Toll Plaza 324		0.5			11,270		13,270
Ketter Drive	13.3						
		0.8			15,840		17,740
I-290 (Eisenhower)	12.5						
		0.4	6,730	-41.3	3,950	-12.6	5,140
Rohlwing Rd	12.1						
		0.9	31,140	-3.0	30,210	-0.7	30,690
Meacham Road	11.2						
Toll Plaza 326		1.8	28,210	-0.4	28,100	0.1	28,290
Roselle Road	9.4						
Toll Plaza 328		1.1	27,110	-0.3	27,040	-0.1	27,050
Wright Boulevard	8.3						
		0.7	24,520	-0.4	24,420	-0.3	24,350
Irving Park Road (IL 19)	7.6						
		0.2	18,170	-1.0	17,990	-1.2	17,720
Springinsauth Rd	7.4						
		0.3	13,170	-1.9	12,920	-2.6	12,500
Gary Avenue	7.1						
Toll Plaza 330		1.1	14,070	-1.8	13,810	-2.6	13,360
Lake Street (US 20)	6.0						

*Toll collection on Illinois Route 390 began July 5, 2016 for segments west of I-290 and on November 1, 2017 for segments east of I-290. Volumes shown are during tolled periods only.

TABLE 6-B: AVERAGE DAILY TRAFFIC VOLUMES BETWEEN INTERCHANGES 2016-2018 (EASTBOUND)

Location	Mile Post	Miles Btwn. Int.	ADT 2016	Average Annual Percent Change	ADT 2017	Average Annual Percent Change	ADT 2018
Busse Rd (IL 83)	15.8						
Toll Plaza 320		1.0			6,470		7,940
Wood Dale Road	14.8						
Toll Plaza 322		1.0			10,940		12,780
Prospect Ave	13.8						
		0.5			11,050		13,300
Ketter Drive	13.3						
Toll Plaza 324		0.8			11,050		13,300
I-290 (Eisenhower)	12.5						
		0.4	6,930	-51.1	3,390	-14.7	5,040
Rohlwing Rd	12.1						
		0.9	26,420	-2.9	25,650	-0.6	26,130
Meacham Road	11.2						
Toll Plaza 326		1.8	29,590	-1.1	29,270	0.1	29,630
Roselle Road	9.4						
Toll Plaza 328		1.8	27,940	-1.1	27,630	-0.2	27,810
Wright Boulevard	7.6						
		0.2	25,400	-1.4	25,050	-0.5	25,130
Irving Park Road (IL 19)	7.4						
		0.3	19,170	-2.3	18,730	-1.6	18,560
Springinsguth Rd	7.1						
		0.9	14,400	-3.6	13,880	-3.1	13,520
Gary Avenue	6.2						
Toll Plaza 330		0.2	15,290	-3.5	14,750	-3.1	14,360
Lake Street (US 20)	6.0						

*Toll collection on Illinois Route 390 began July 5, 2016 for segments west of I-290 and on November 1, 2017 for segments east of I-290. Volumes shown are during tolled periods only.



**TABLE 6-C: GENERAL STATISTICS FOR MAINLINE PLAZAS
(Vehicles/Hour)**

Mainline Plaza	Dir.	30th HV	Period	Mean	Med.	Max.	Min.	Std. Dev.	85th %
320 Lively Boulevard	EB	1,303	AM Peak	1,023	991	1,454	531	189	1,238
			PM Peak	493	494	703	287	72	567
			OFF Peak	319	273	1,353	14	248	517
			Weekend	257	212	1,338	25	208	462
			Holidays	233	177	1,114	22	200	417
	WB	1,443	AM Peak	257	236	496	115	76	358
			PM Peak	1,130	1,137	1,770	627	211	1,363
			OFF Peak	263	231	1,072	13	208	460
			Weekend	205	152	1,592	14	211	329
			Holidays	188	133	1,152	11	197	343
322 Mittel Drive	EB	2,237	AM Peak	1,769	1,683	2,369	1,036	323	2,119
			PM Peak	712	716	975	463	80	796
			OFF Peak	530	402	2,153	23	436	870
			Weekend	394	316	2,237	39	357	750
			Holidays	353	258	1,980	30	341	633
	WB	2,435	AM Peak	470	426	806	236	125	626
			PM Peak	2,033	2,042	2,822	1,338	269	2,321
			OFF Peak	464	397	1,908	19	297	840
			Weekend	341	241	2,567	24	369	560
			Holidays	308	209	1,882	19	343	578
324 Hamilton Lakes Boulevard	EB	2,269	AM Peak	1,783	1,684	2,409	1,000	338	2,154
			PM Peak	744	749	1,003	491	90	837
			OFF Peak	545	445	2,290	23	445	884
			Weekend	423	352	2,303	41	364	771
			Holidays	384	302	1,994	35	349	652
	WB	2,584	AM Peak	587	536	974	286	140	761
			PM Peak	2,197	2,211	3,001	1,484	266	2,465
			OFF Peak	530	470	1,991	22	416	937
			Weekend	410	313	2,848	30	403	670
			Holidays	370	264	2,022	24	378	690

(cont'd)



**TABLE 6-C: GENERAL STATISTICS FOR MAINLINE PLAZAS
(Vehicles/Hour)**

Mainline Plaza	Dir.	30th HV	Period	Mean	Med.	Max.	Min.	Std. Dev.	85th %
326 Plum Grove Road	EB	4,435	AM Peak	3,639	3,385	4,618	1,978	620	4,343
			PM Peak	1,638	1,645	1,994	1,179	114	1,746
			OFF Peak	1,104	1,118	4,389	68	861	1,737
			Weekend	1,090	1,068	4,291	92	753	1,721
			Holidays	979	957	3,985	82	695	1,665
	WB	4,225	AM Peak	1,102	1,058	1,482	490	181	1,303
			PM Peak	3,872	3,877	4,695	2,288	291	4,166
			OFF Peak	1,056	1,127	3,215	64	757	1,753
			Weekend	1,045	1,018	4,077	105	738	1,639
			Holidays	947	888	3,499	62	716	1,544
328 Mitchell Boulevard	EB	4,139	AM Peak	3,418	3,129	4,310	1,827	585	4,083
			PM Peak	1,610	1,619	1,910	1,049	113	1,723
			OFF Peak	1,031	1,059	4,107	55	803	1,624
			Weekend	1,022	1,003	3,992	86	708	1,616
			Holidays	918	900	3,713	74	650	1,571
	WB	4,121	AM Peak	1,069	988	1,456	461	209	1,302
			PM Peak	3,759	3,765	4,592	2,219	293	4,047
			OFF Peak	1,005	1,061	3,371	67	725	1,671
			Weekend	998	973	3,963	91	712	1,558
			Holidays	904	853	3,687	66	690	1,475
330 Lake Street	EB	2,241	AM Peak	1,854	1,734	2,420	963	293	2,182
			PM Peak	741	742	923	480	66	807
			OFF Peak	527	504	2,092	27	426	868
			Weekend	532	521	2,174	41	372	834
			Holidays	480	478	2,031	36	340	788
	WB	2,255	AM Peak	447	448	653	242	64	515
			PM Peak	1,994	1,996	2,516	1,104	187	2,178
			OFF Peak	487	487	1,788	27	367	834
			Weekend	496	481	2,152	43	369	778
			Holidays	454	415	2,025	29	357	749

AM Peak = Weekday 6:00 AM To 8:00 AM Except Fridays
 PM Peak = Weekday 4:00 PM To 6:00 PM Except Fridays
 OFF Peak = Weekdays Except Fridays and AM and PM Peak Periods
 Weekend = Fridays, Saturdays, and Sundays
 Holidays = See Page 1-6 for a list of Holidays.

TABLE 6-D: INDEXED MONTHLY VARIATION BY MAINLINE PLAZA

Month	Lively Boulevard	Mittel Drive	Hamilton Lakes Boulevard	Plum Grove Road	Mitchell Boulevard	Lake Street
January	0.78	0.83	0.83	0.89	0.89	0.90
February	0.86	0.90	0.90	0.93	0.93	0.94
March	0.92	0.95	0.95	0.99	0.99	1.00
April	0.96	0.98	0.98	1.00	1.00	1.00
May	1.03	1.03	1.04	1.05	1.06	1.08
June	1.05	1.05	1.06	1.07	1.07	1.11
July	1.06	1.03	1.04	1.02	1.02	1.04
August	1.10	1.08	1.08	1.06	1.06	1.06
September	1.04	1.01	1.01	1.01	1.01	0.99
October	1.14	1.12	1.10	1.05	1.04	1.01
November	1.09	1.06	1.05	0.98	0.98	0.95
December	0.99	0.96	0.96	0.95	0.95	0.93

TABLE 6-E: INDEXED DAILY VARIATION BY MAINLINE PLAZA

Month	Day	Lively Boulevard	Mittel Drive	Hamilton Lakes Boulevard	Plum Grove Road	Mitchell Boulevard	Lake Street
August	Monday	1.11	1.09	1.09	1.08	1.08	1.07
	Tuesday	1.07	1.05	1.05	1.04	1.04	1.03
	Wednesday	1.06	1.04	1.05	1.04	1.04	1.03
	Thursday	1.07	1.05	1.05	1.04	1.04	1.04
	Friday	1.06	1.04	1.04	1.04	1.04	1.04
	Saturday	1.06	1.03	1.04	1.07	1.08	1.09
	Sunday	1.08	1.05	1.05	1.06	1.07	1.07
December	Monday	0.95	0.92	0.93	0.95	0.94	0.93
	Tuesday	0.93	0.90	0.91	0.92	0.91	0.90
	Wednesday	1.05	1.03	1.03	0.98	0.97	0.95
	Thursday	1.05	1.04	1.03	0.98	0.97	0.95
	Friday	1.06	1.05	1.04	1.00	1.00	0.99
	Saturday	1.07	1.03	1.02	0.98	0.98	0.96
	Sunday	1.00	0.98	0.97	0.96	0.96	0.94

Table 6-E includes Monthly Variation

TABLE 6-F: ANNUAL TOTAL TRANSACTIONS BY TOLL PLAZA

Plaza	Plaza Code*	2017	2018	Percentage Change
320 Lively Boulevard**	M	680,177	5,306,663	680.2%
322 Mittel Drive**	M	1,231,795	8,857,100	619.0%
324 Hamilton Lakes Boulevard**	M	1,361,920	9,690,906	611.6%
325 Ketter Drive**	E	278,637	1,630,424	485.1%
326 Plum Grove Road	M	20,942,108	21,134,933	0.9%
328 Mitchell Boulevard	M	19,953,488	20,017,700	0.3%
330 Lake Street	M	10,421,855	10,114,038	-3.0%
IL Route 390 Total		54,869,980	76,751,764	39.9%

* M=Mainline / R=Ramp / A=Attended Ramp Plaza / E=Electronic Toll Collection Only Ramp
 1=Toll Collected in One Direction Only

** Plazas 320-325 opened November 2017.

TABLE 6-G: AVERAGE DAILY TRAFFIC DATA

Year	Average Daily Total			Average Trip
	Vehicles	Vehicle Miles	Transactions	Length (Miles)
2016	72,360	312,926	142,229	4.32
2017	98,970	365,800	198,834	3.70
2018	100,140	380,915	210,279	3.80



FIGURE 6-B

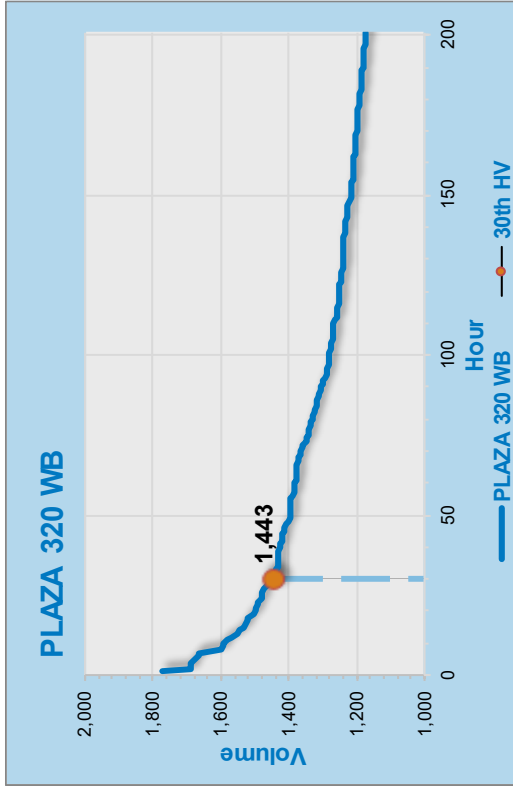

FIGURE 6-D

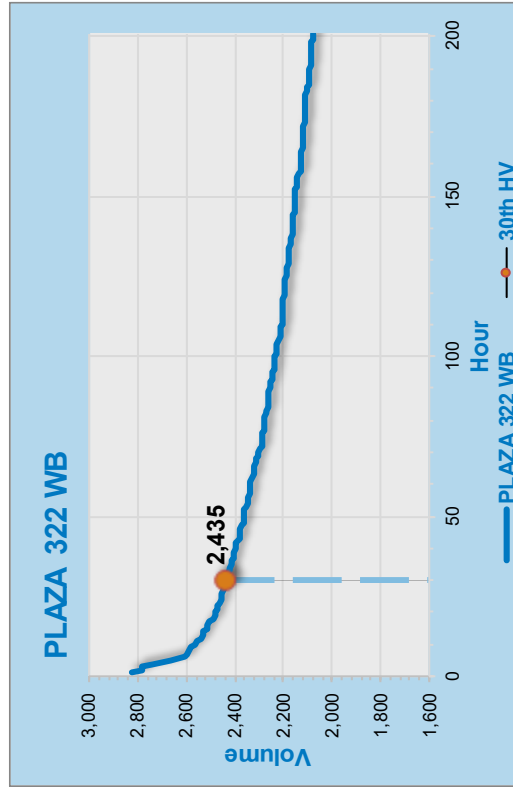

FIGURE 6-A

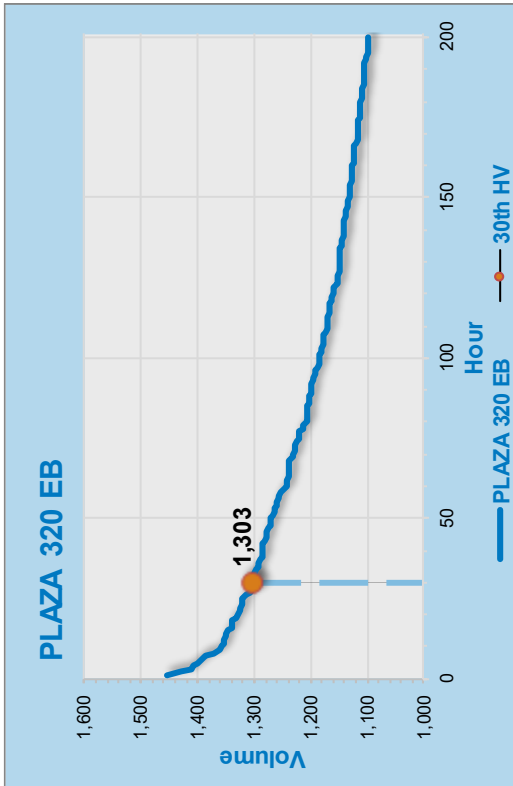
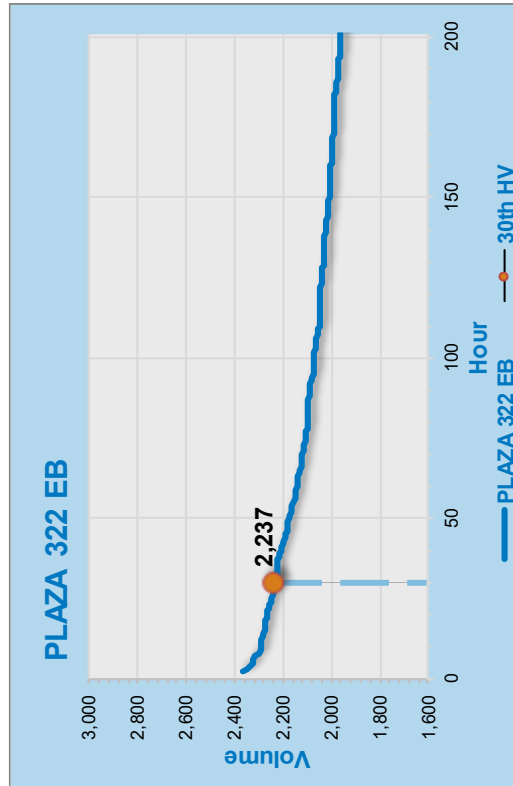

FIGURE 6-C



MAINLINE PLAZA HIGHEST HOURLY VOLUME

FIGURE 6-F

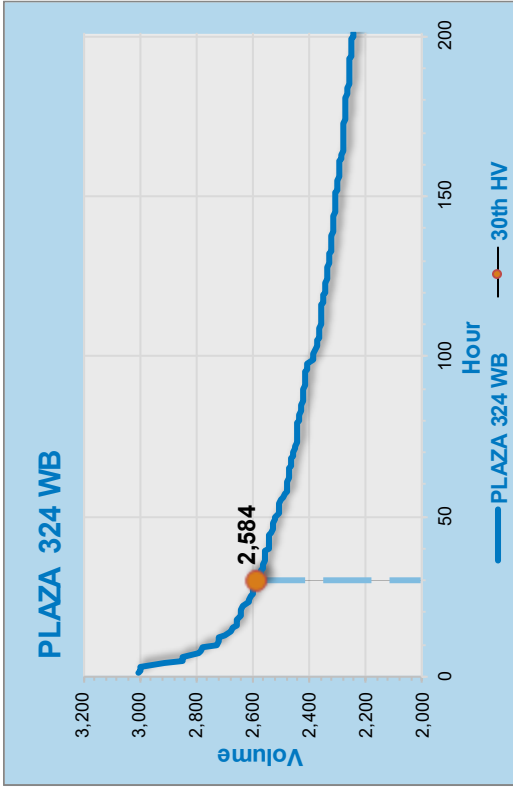

FIGURE 6-E

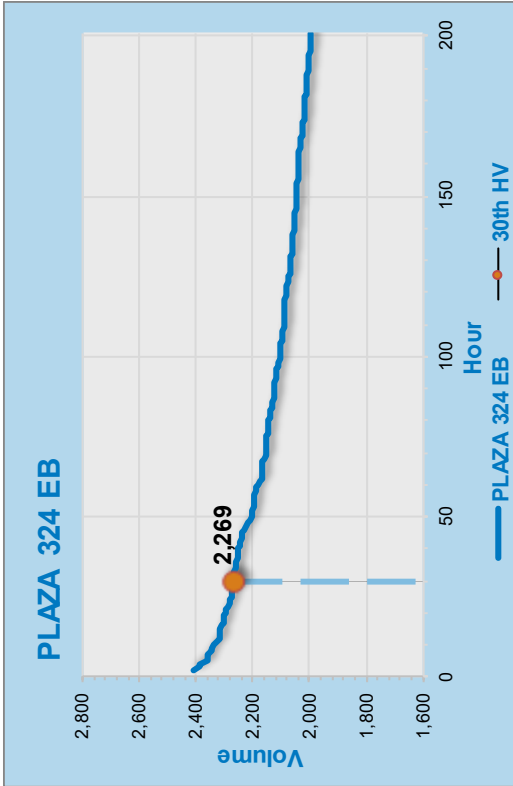

FIGURE 6-H

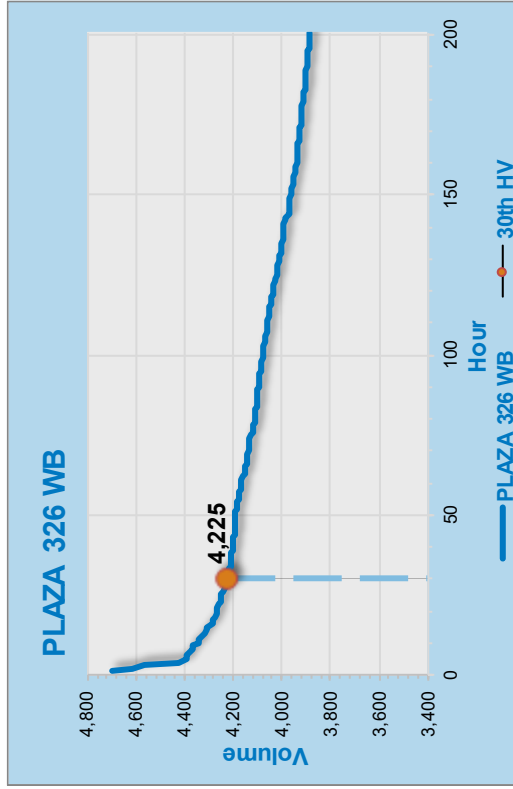
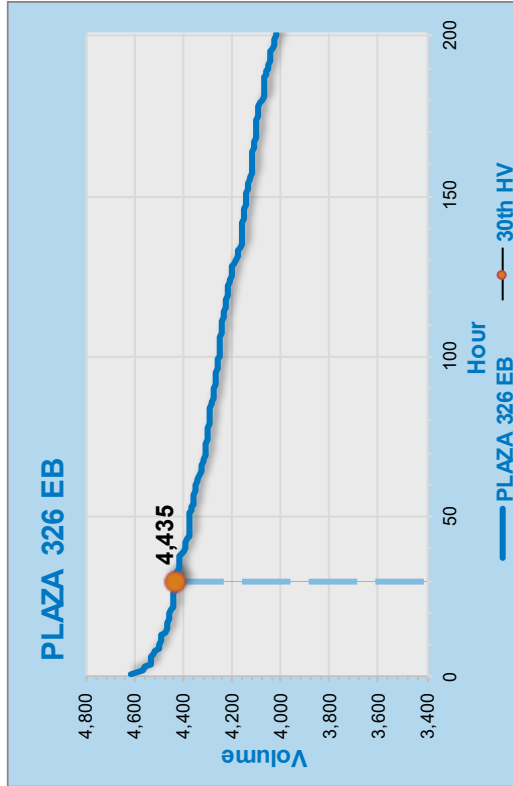

FIGURE 6-G



MAINLINE PLAZA HIGHEST HOURLY VOLUME



FIGURE 6-J

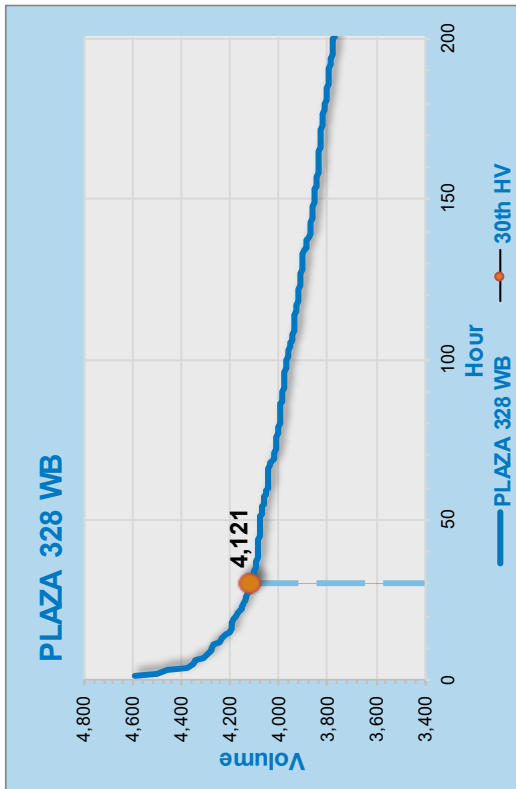

FIGURE 6-L

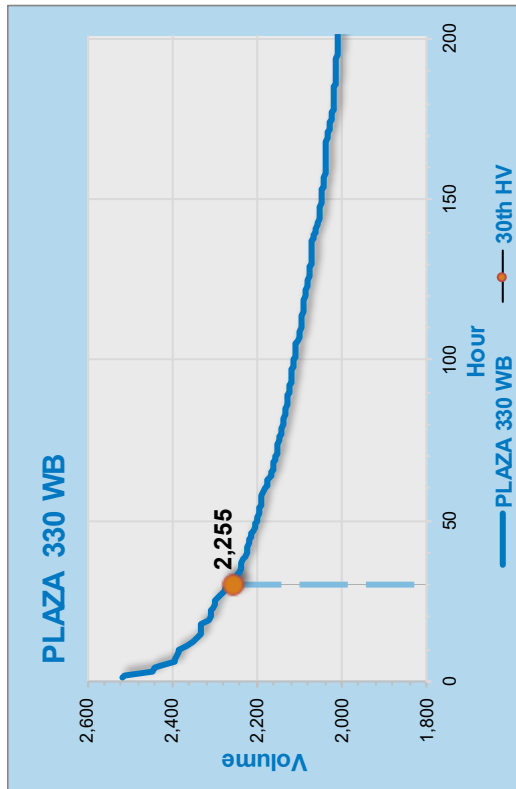

FIGURE 6-I

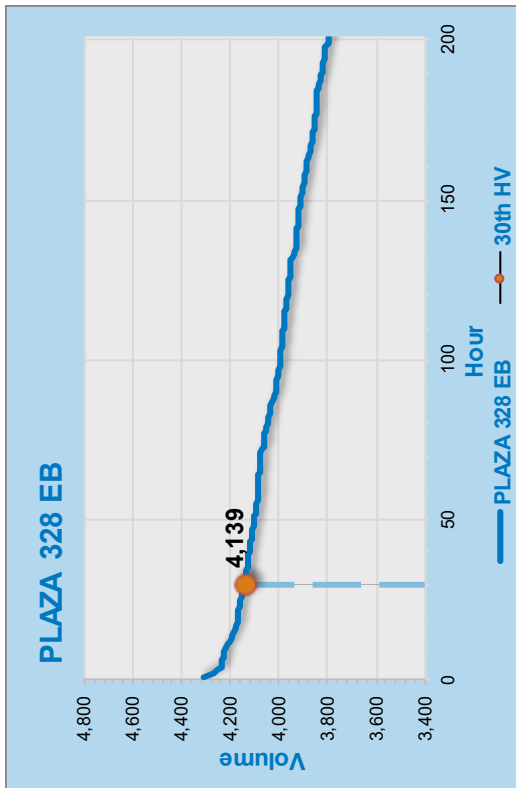
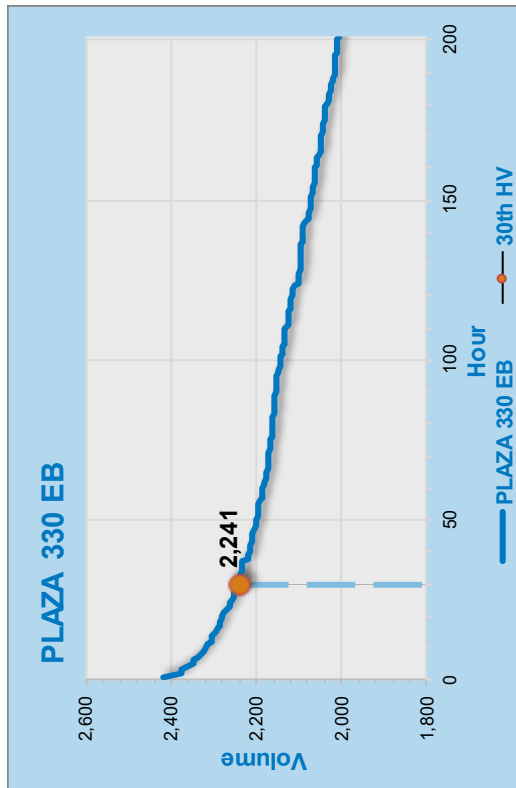

FIGURE 6-K



MAINLINE PLAZA HIGHEST HOURLY VOLUME



FIGURE 6-M

Plaza 320 opened in November 2018.

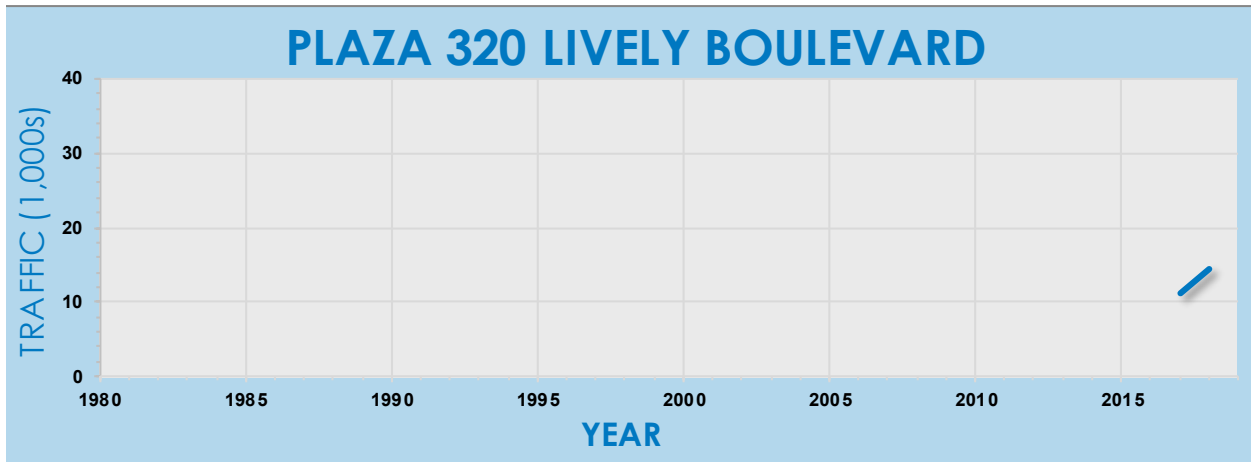

FIGURE 6-N

Plaza 322 opened in November 2018.

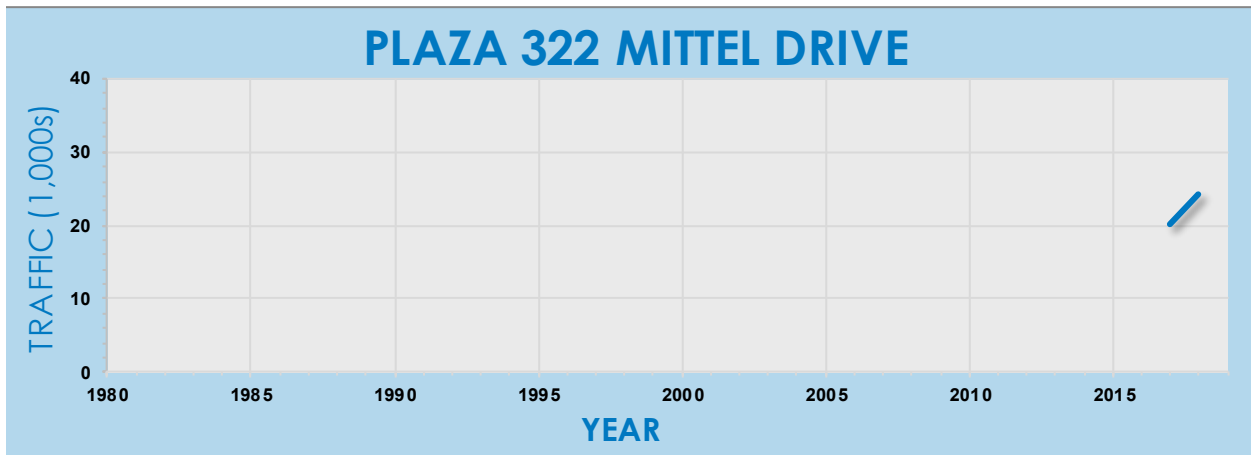
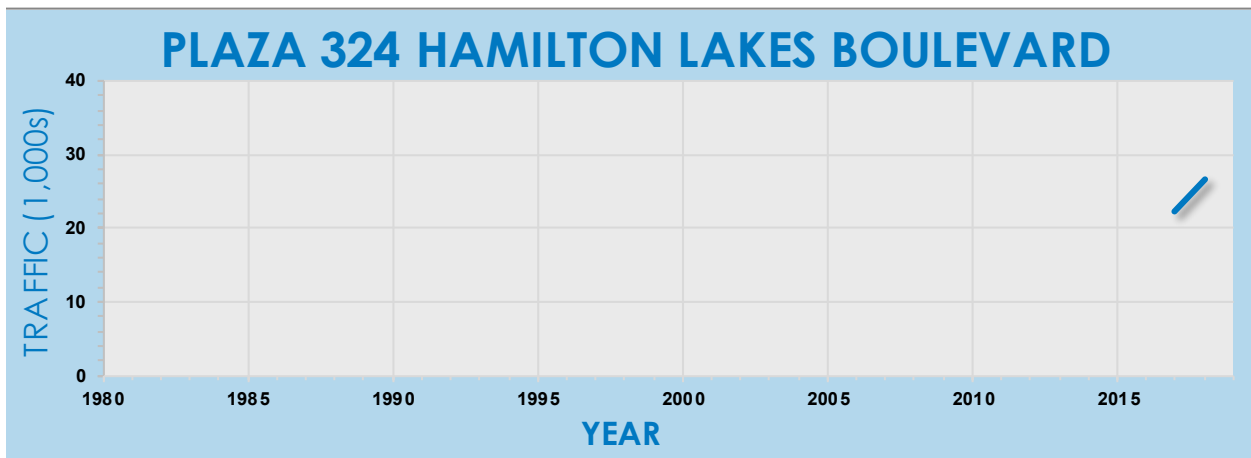

FIGURE 6-O

Plaza 324 opened in November 2018.



AVERAGE DAILY TRAFFIC TRENDS



FIGURE 6-P

Plaza 325 opened in November 2018.

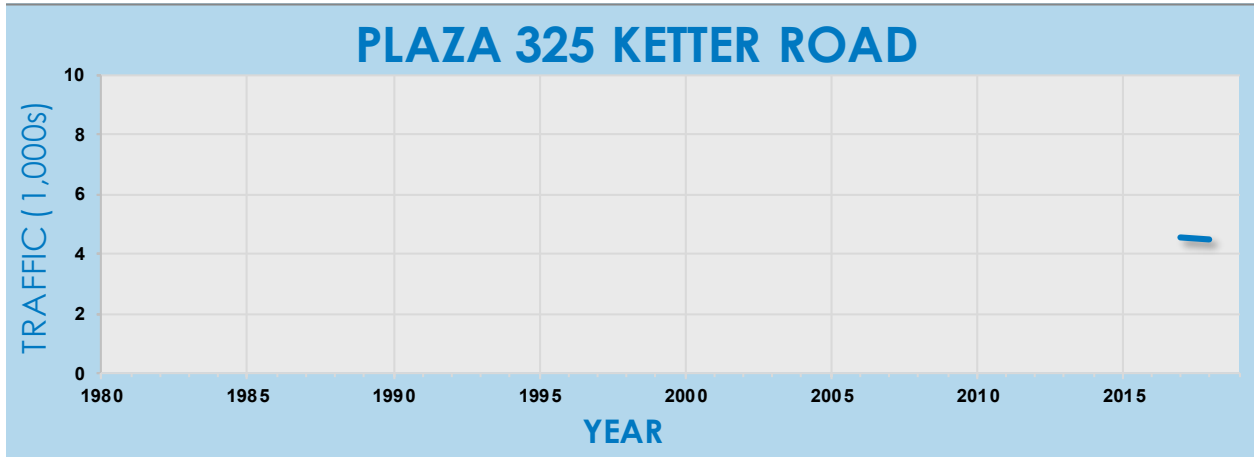

FIGURE 6-Q

Plaza 326 opened in July 2016.

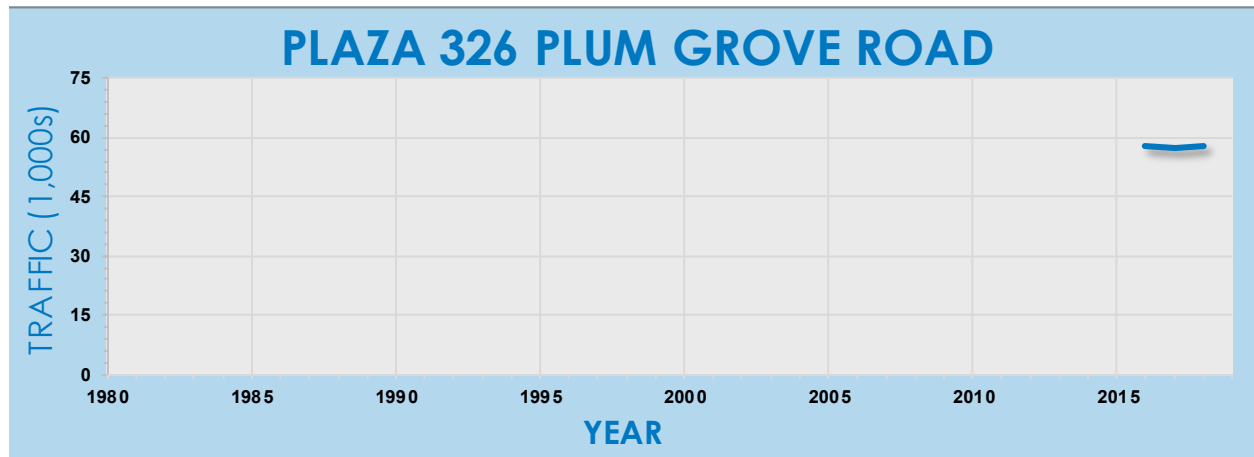
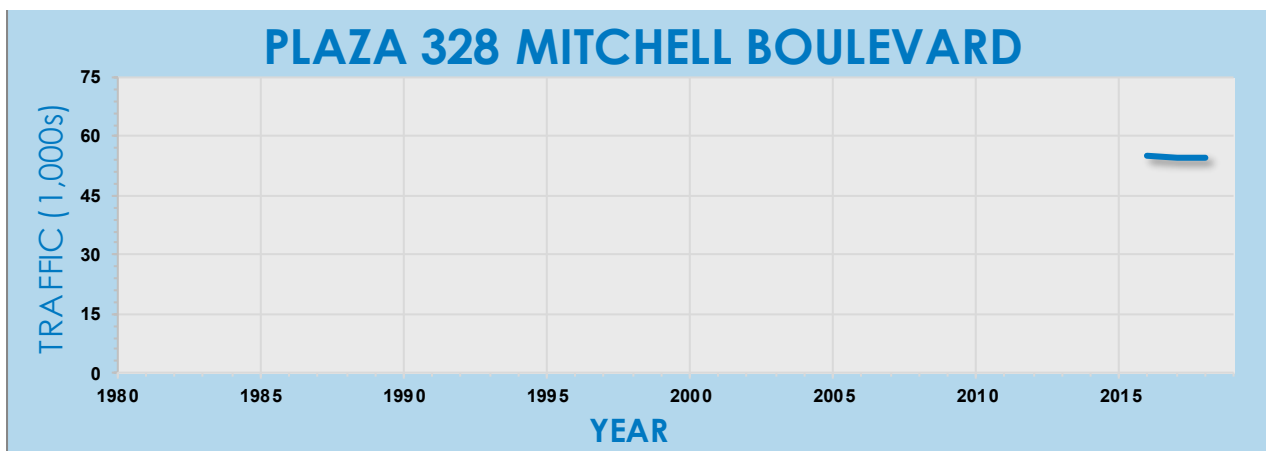

FIGURE 6-R

Plaza 328 opened in July 2016.



AVERAGE DAILY TRAFFIC TRENDS



FIGURE 6-S

Plaza 330 opened in July 2016.

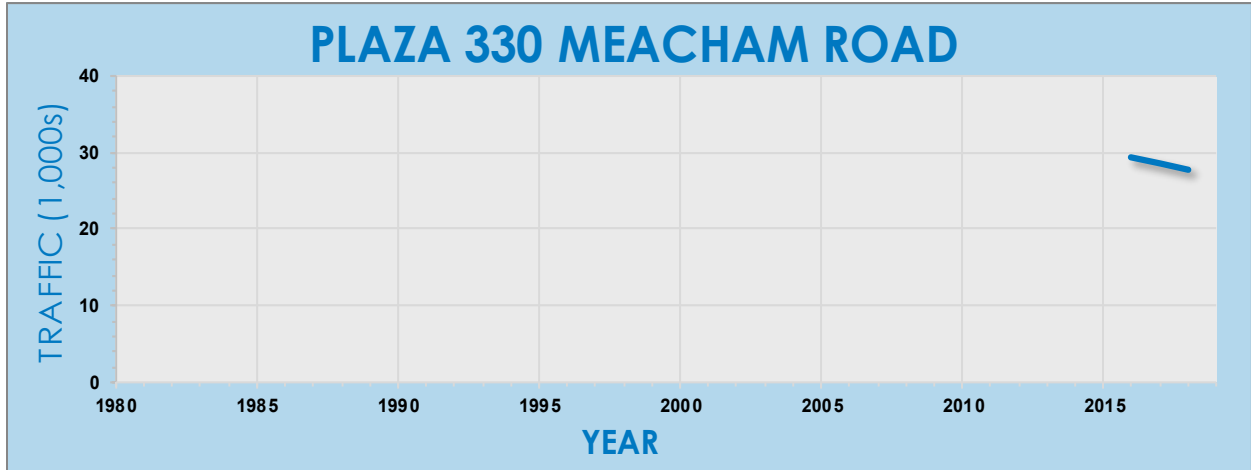

AVERAGE DAILY TRAFFIC TRENDS

AVERAGE WEEKDAY SPEED DISTRIBUTIONS, WESTERN SECTION

FIGURE 6-T

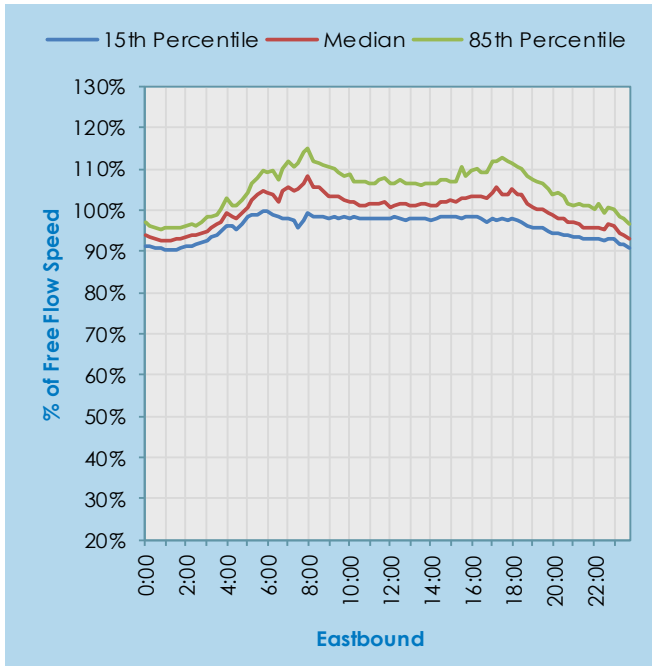
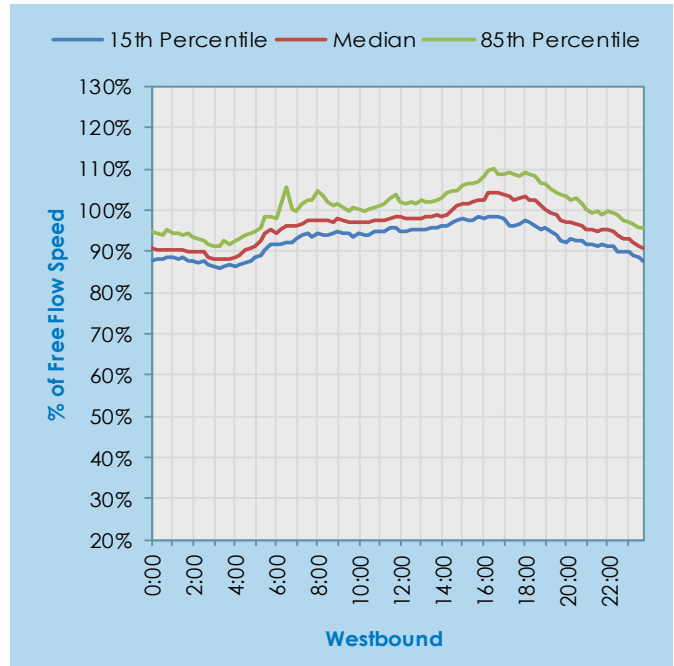

FIGURE 6-U



AVERAGE WEEKDAY SPEED DISTRIBUTIONS, EASTERN SECTION

FIGURE 6-V

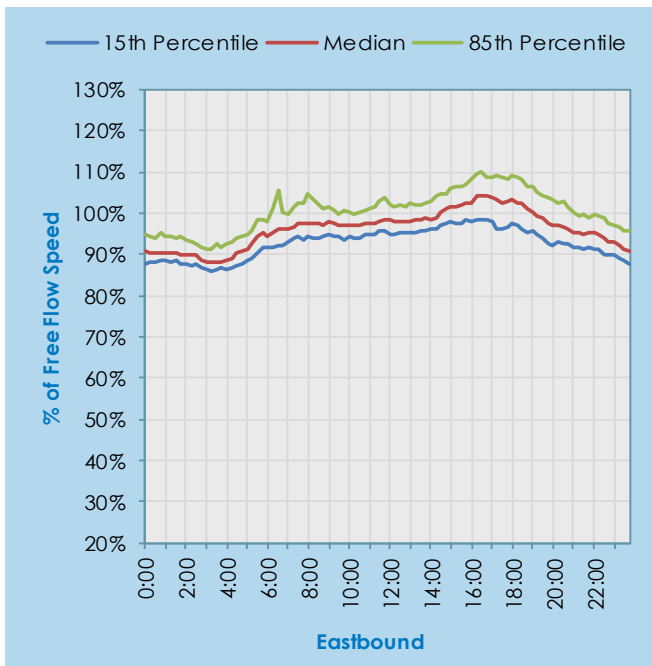
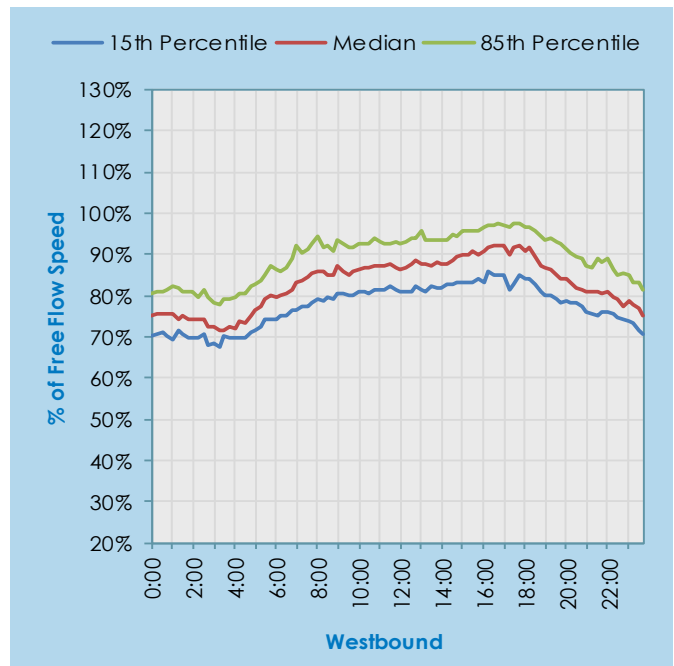
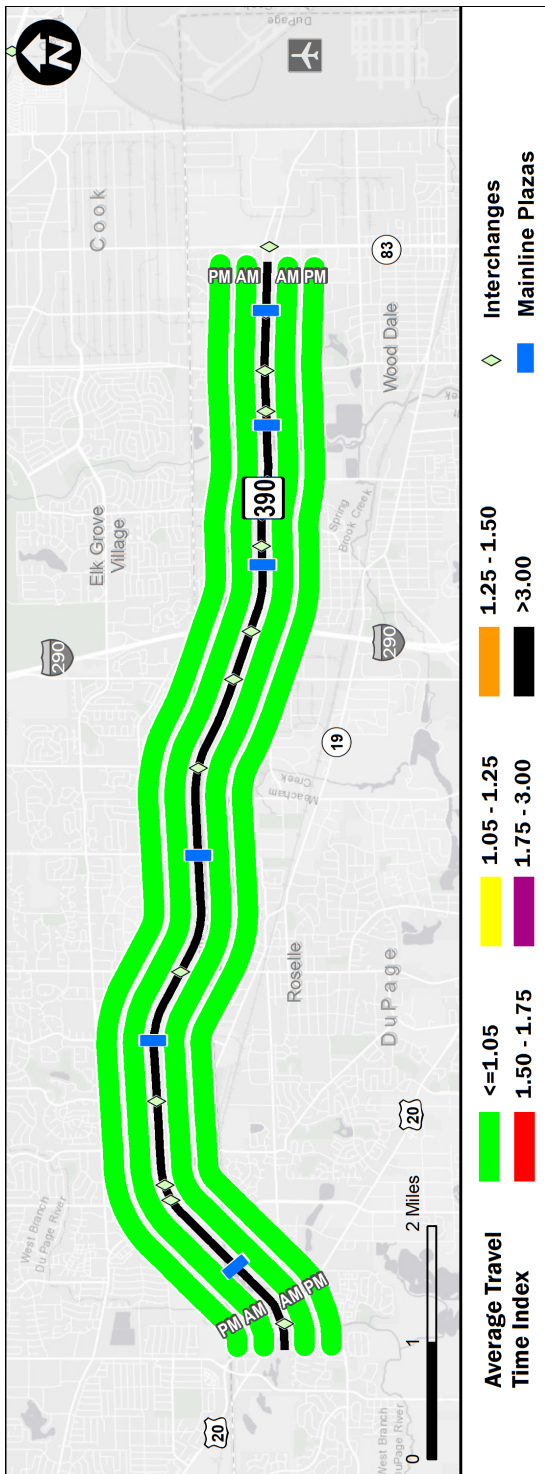

FIGURE 6-W





Quarter	Range	Average Speed (mph)		Average Travel Time Index		Planning Time Index		Total Delay (veh-hrs / 1000 VMT)		Average Daily Delay (veh-hrs)		Percent Congested Travel	
		AM	PM	AM	PM	AM	PM	AM	PM	AM	PM	AM	PM
Western Section*													
1	January-March	62	66	0.97	0.91	1.15	1.00	0.4	0.1	22	5	21	5
2	April-June	62	66	0.97	0.91	1.04	0.97	0.3	0.1	17	8	17	7
3	July-September	64	61	0.93	0.99	1.03	1.11	0.2	0.4	12	26	7	33
4	October-December	65	62	0.92	0.97	0.98	1.10	0.1	0.2	9	15	8	31
Total	2018 Entire Year	63	63	0.95	0.95	1.05	1.05	0.2	0.2	15	13	14	19

*Data is shown only for the western section of IL 390 due to the unreliability of INRIX data for IL 390 east of I-290. Roadway performance measures sections and terms are defined on pages 1-4 and 1-5.

FIGURE 6-X: ROADWAY PERFORMANCE MEASURES

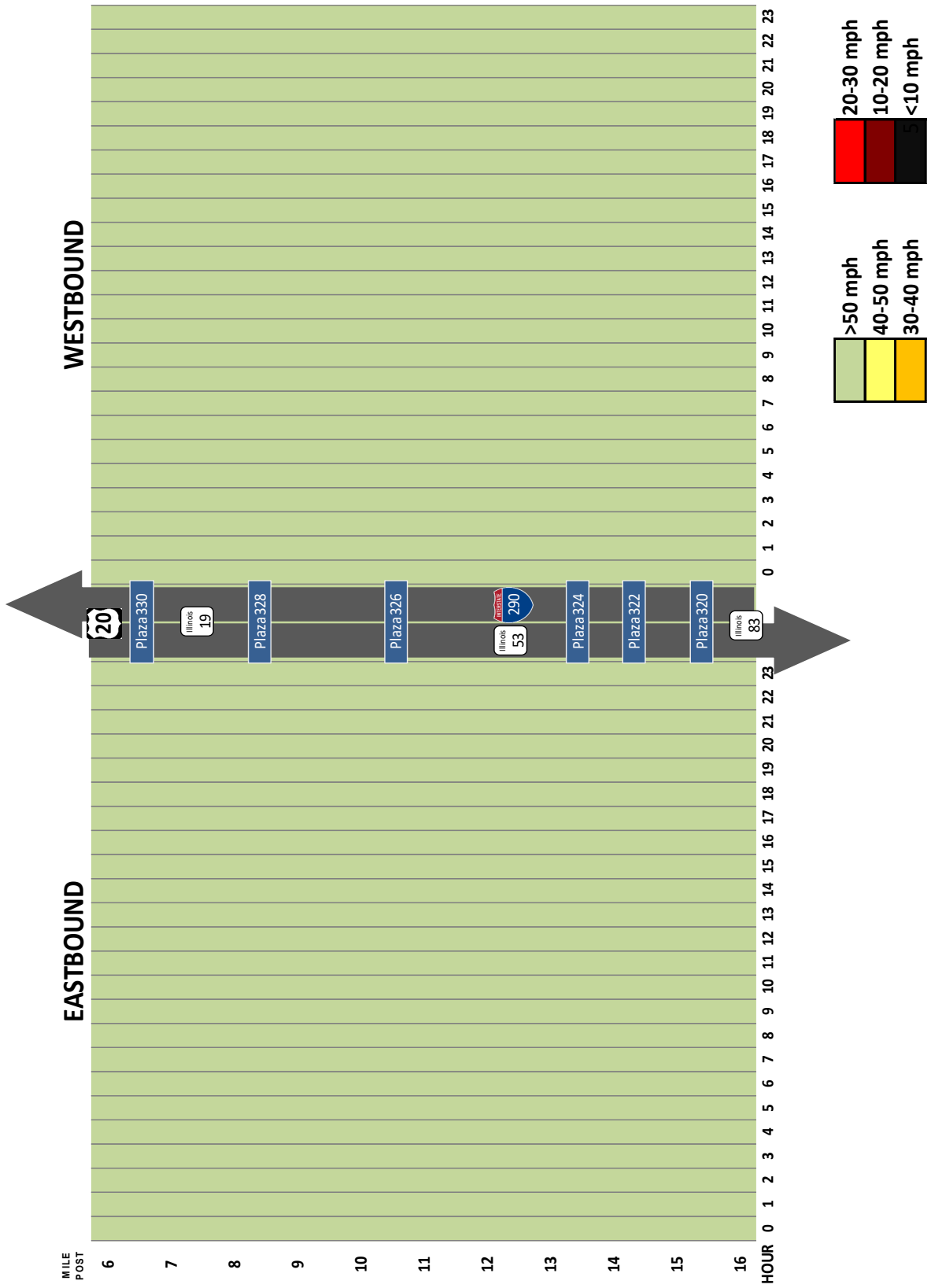
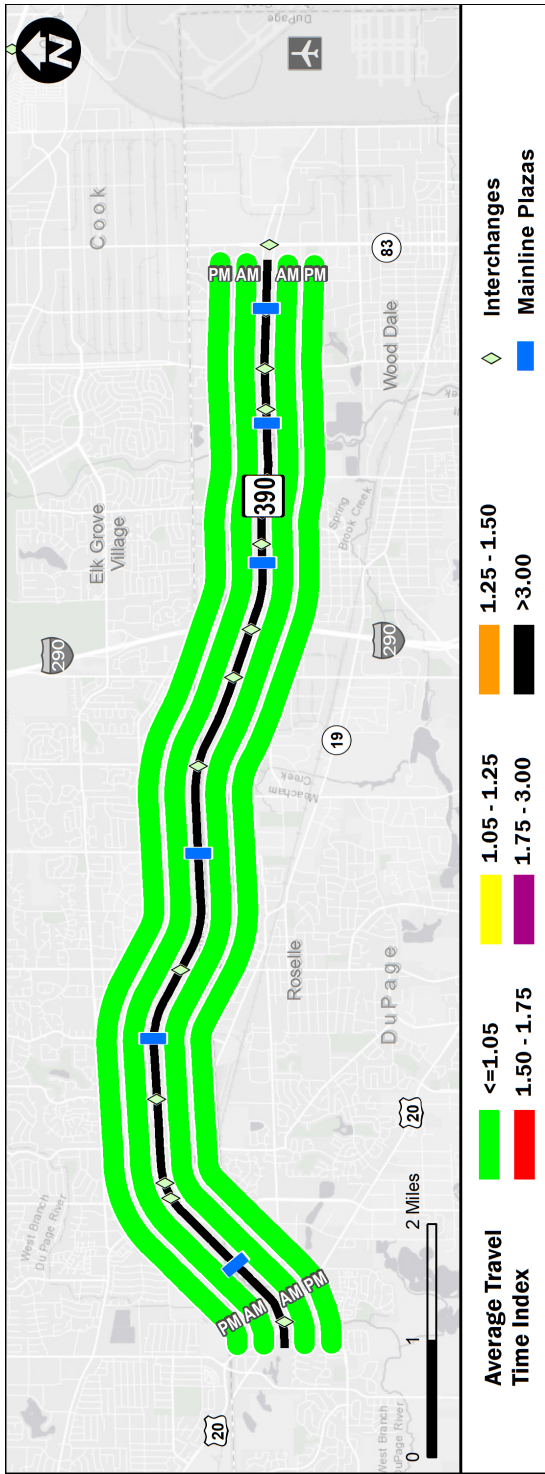

FIGURE 6-Y: AVERAGE SPEED CONTOURS, MP 5.9 TO 15.8



Quarter	Range	Average Speed (mph)		Average Travel Time Index		Planning Time Index		Total Delay (veh-hrs / 1000 VMT)		Average Daily Delay (veh-hrs)		Percent Congested Travel	
		AM	PM	AM	PM	AM	PM	AM	PM	AM	PM	AM	PM
Western Section*													
1	January-March	62	66	0.97	0.91	1.15	1.00	0.4	0.1	22	5	21	5
2	April-June	62	66	0.97	0.91	1.04	0.97	0.3	0.1	17	8	17	7
3	July-September	64	61	0.93	0.99	1.03	1.11	0.2	0.4	12	26	7	33
4	October-December	65	62	0.92	0.97	0.98	1.10	0.1	0.2	9	15	8	31
Total	2018 Entire Year	63	63	0.95	0.95	1.05	1.05	0.2	0.2	15	13	14	19

*Data is shown only for the western section of IL 390 due to the unreliability of INRIX data for IL 390 east of I-290. Roadway performance measures sections and terms are defined on pages 1-4 and 1-5.

FIGURE 6-N: ROADWAY PERFORMANCE MEASURES

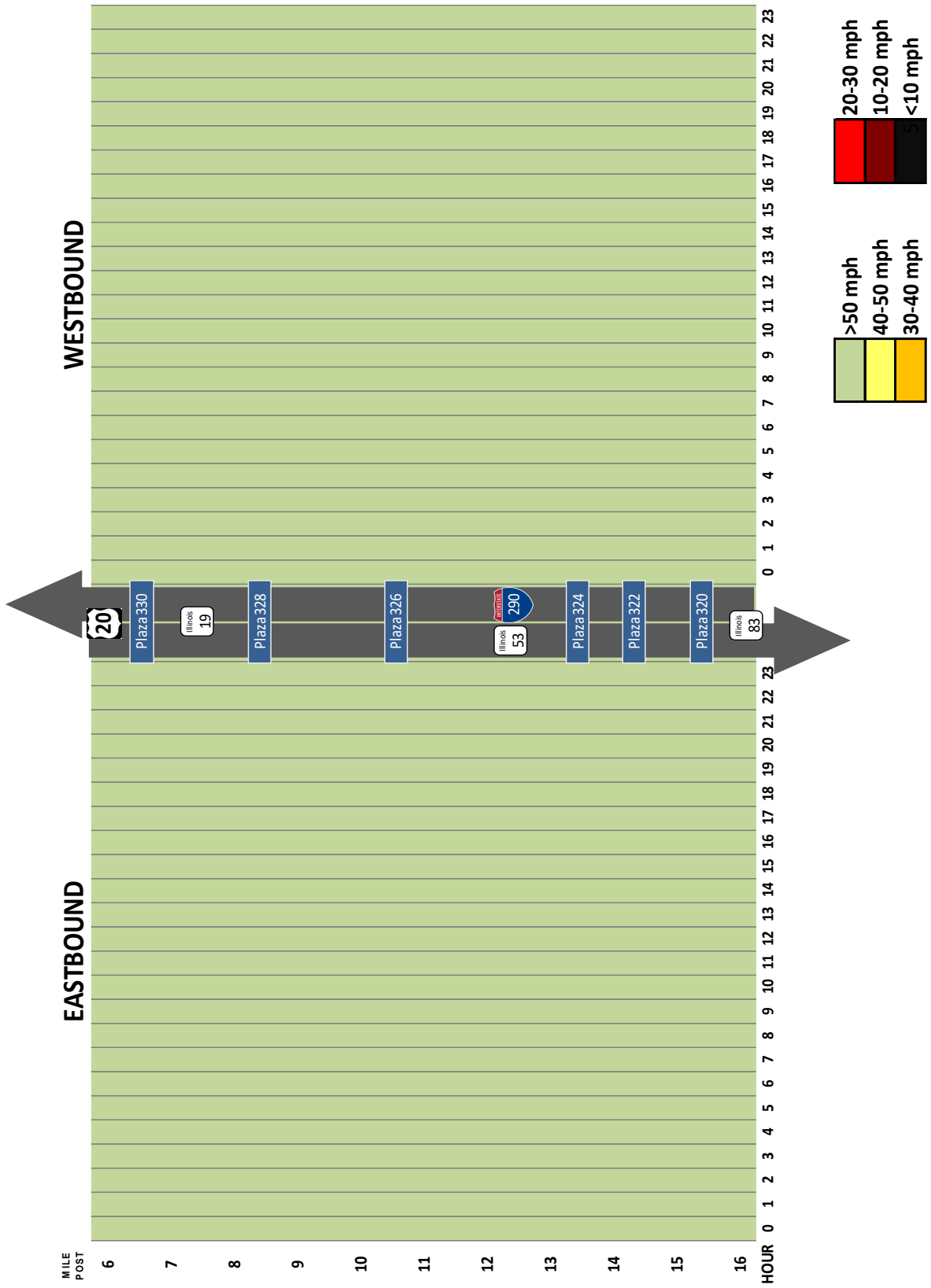
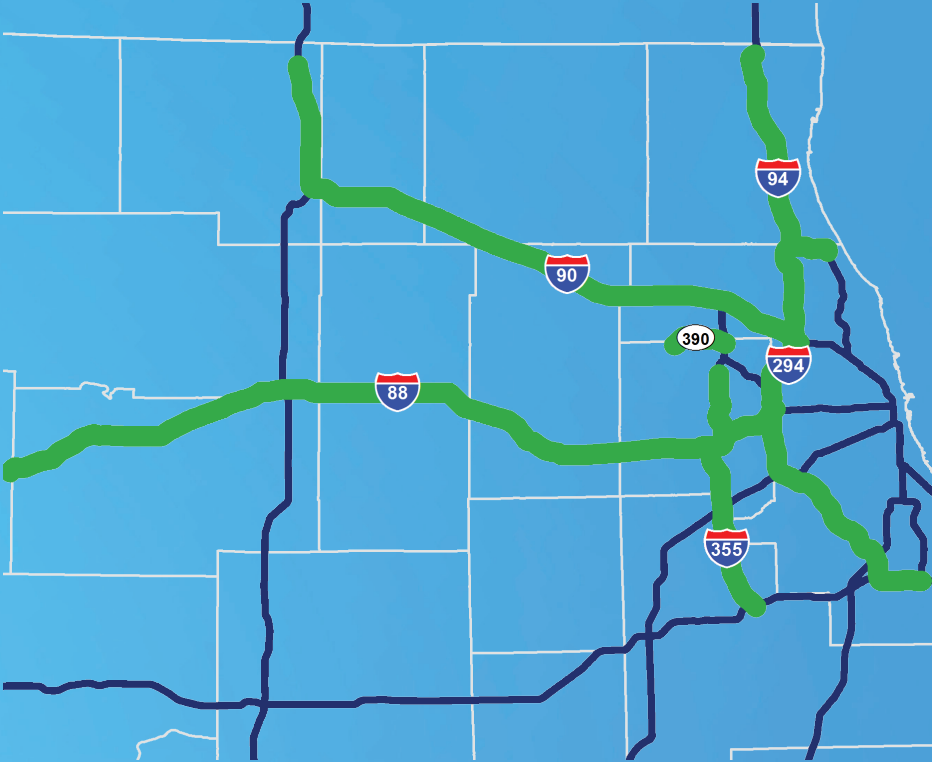
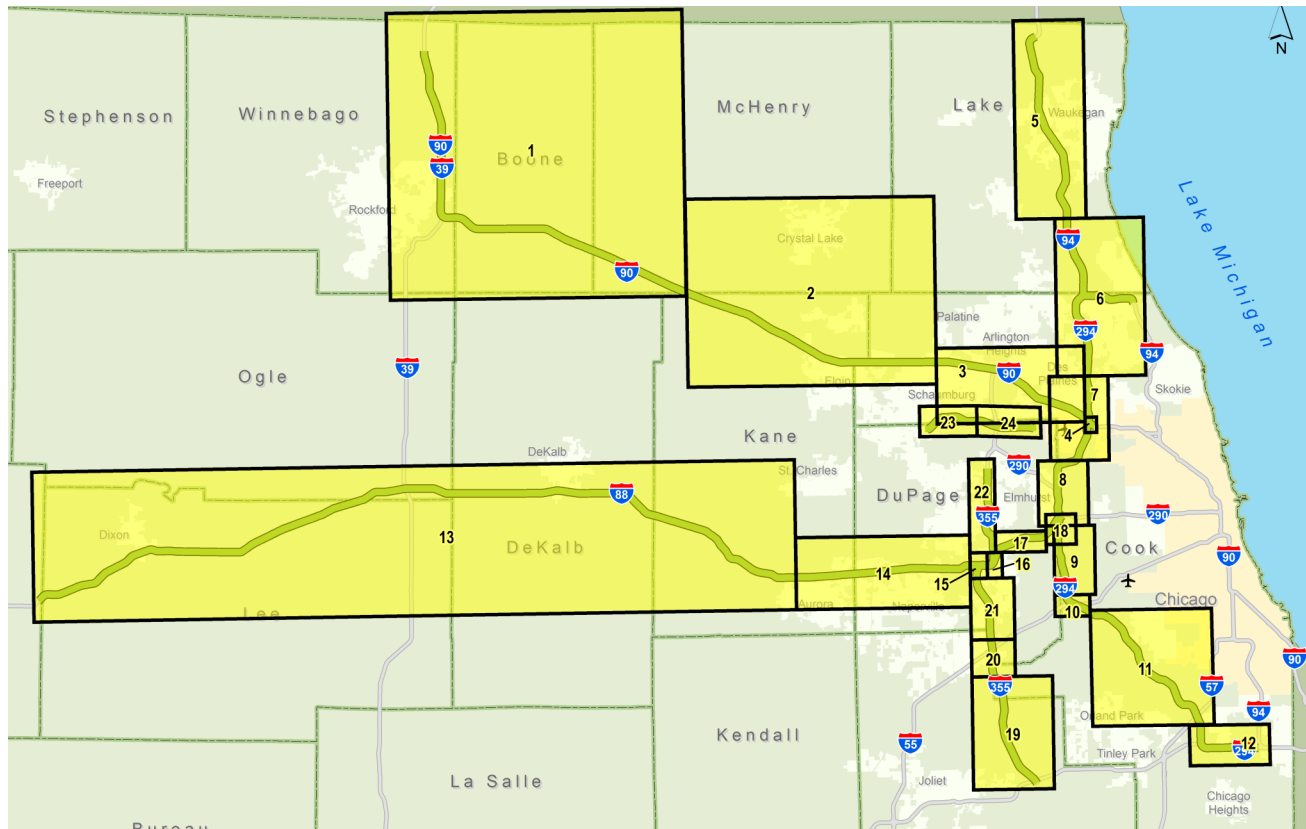

FIGURE 6-0: AVERAGE SPEED CONTOURS, MP 5.9 TO 15.8

Appendices



PAGE NUMBERS FOR TOLLWAY SCHEMATICS, APPENDICES A TO C



Jane Addams Memorial Tollway

- 1 – From Rockton Road to Marengo (Plaza 7)
- 2 – From U.S. Route 20, Marengo to Barrington Road
- 3 – From Roselle Road to Devon Avenue
- 4 – From Tri-State Tollway to Kennedy Expressway

Tri-State Tollway

- 5 – From Russell Road to Lake Forest Oasis
- 6 – From Town Line Road (Illinois 60) to Golf Road (Illinois 58) and Edens Spur
- 7 – From Dempster Street to O'Hare Oasis
- 8 – From North Avenue / Lake Street to Reagan Memorial Tollway (I-88)
- 9 – From Roosevelt Road to Hinsdale Oasis
- 10 – From Joliet Road (Plaza 37) to Willow Springs Road (Plaza 34)
- 11 – From Archer / La Grange / 79th Street to I-57
- 12 – From 159th Street (Plaza 40) to Bishop Ford / Kingery Expressway

Reagan Memorial Tollway

- 13 – From Illinois Route 26 to Orchard Road
- 14 – From Illinois Route 31 to Illinois Route 53
- 15 – Veterans Memorial Tollway West Interchange
- 16 – Veterans Memorial Tollway East Interchange
- 17 – From Highland Avenue to Harger Road
- 18 – From Roosevelt Road to Eisenhower Expressway (I-290)

Veterans Memorial Tollway

- 19 – From Interstate 80 to 127th Street
- 20 – At Interstate 55
- 21 – From Boughton Road To Maple Avenue
- 22 – From Ogden Avenue / West Interchange to Army Trail Road

Illinois Route 390 Tollway

- 23 – From Lake Street to Plum Grove Road (Plaza 326)
- 24 – From Plum Grove Road (Plaza 326) to Busse Road (Illinois 83)

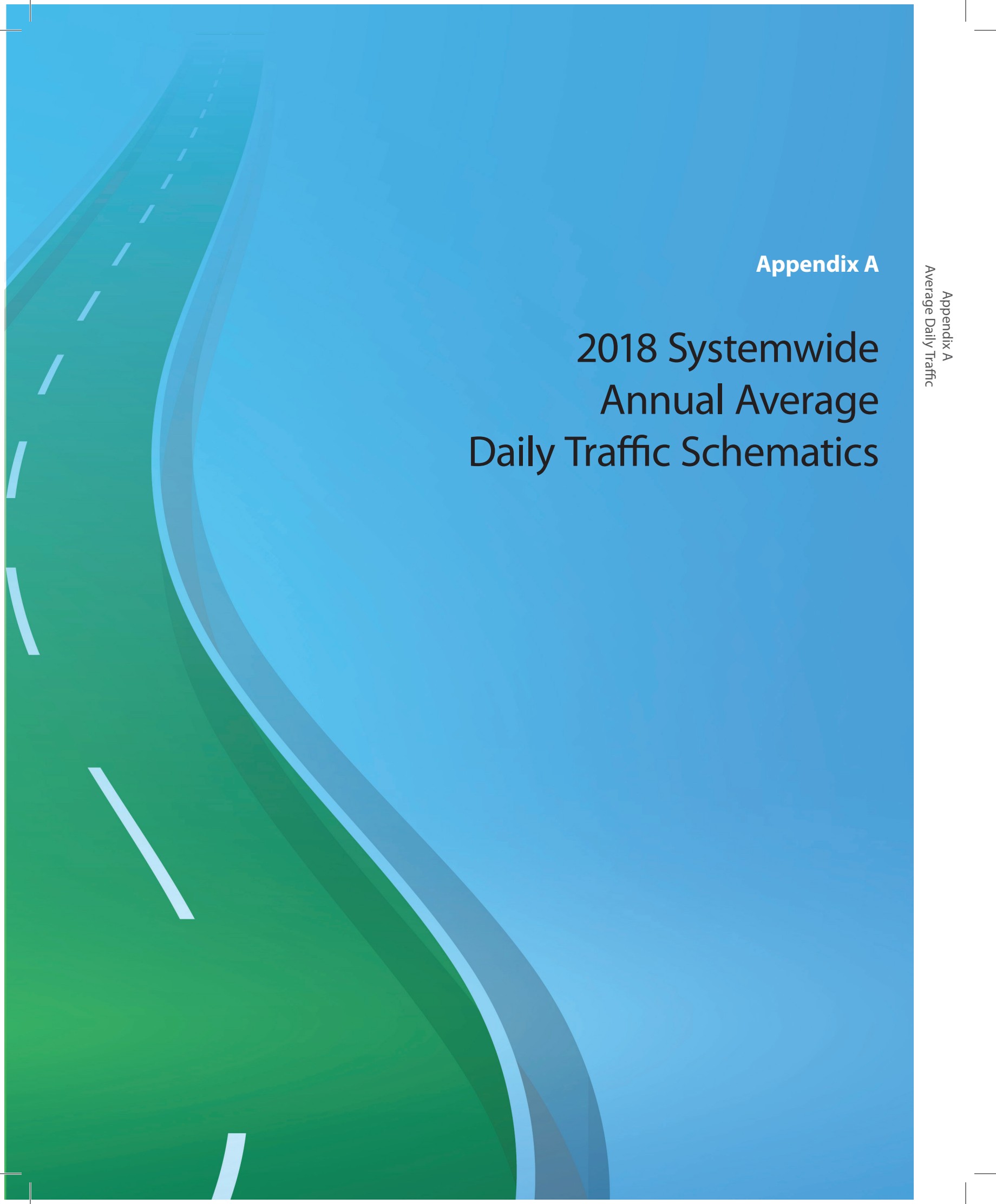

Appendix A

**2018 Systemwide
Annual Average
Daily Traffic Schematics**



2018 Annual Average Daily Traffic

On Jane Addams Memorial Tollway, from Rockton Road to Marengo (Plaza 7)

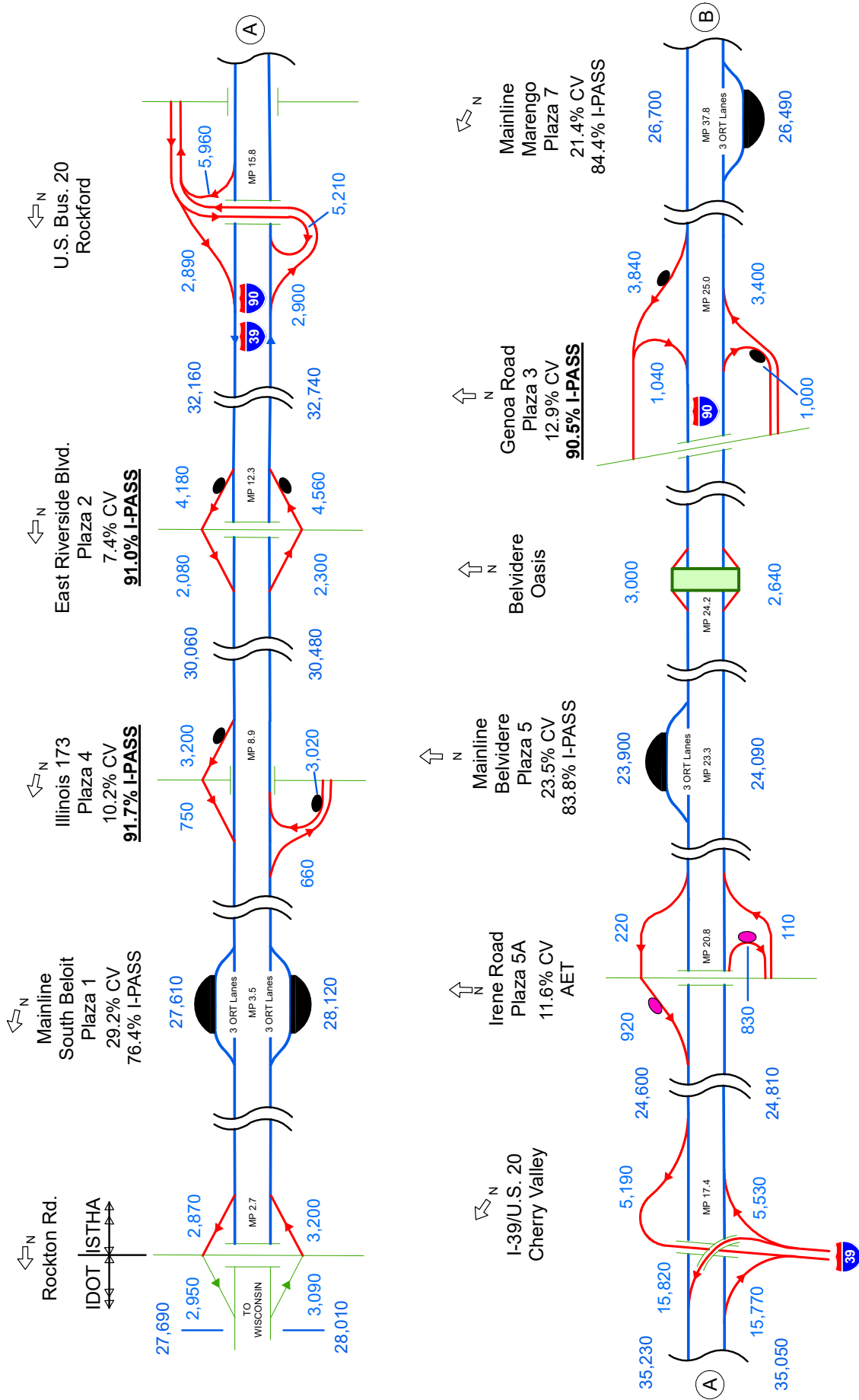

CV = Commercial Vehicles
 I-PASS = I-PASS Electronic Toll Collection
 ORT = Open Road Tolling Lanes
 AET = All Electronic Tolling





2018 Annual Average Daily Traffic

On Jane Addams Memorial Tollway, from U.S. 20, Marengo to Barrington Road

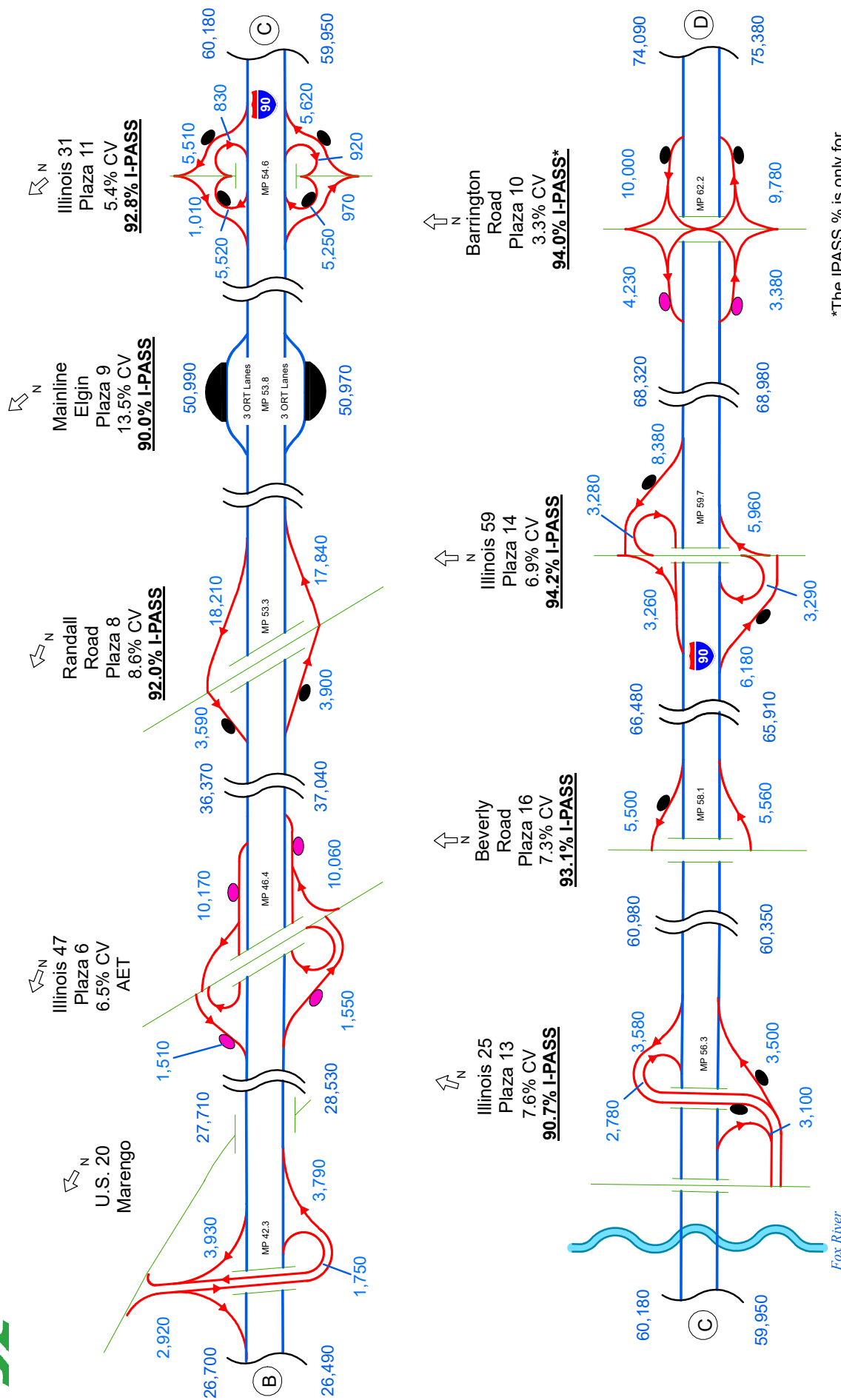

*The IPASS % is only for to/from East direction

CV = Commercial Vehicles
 I-PASS = I-PASS Electronic Toll Collection
 ORT = Open Road Tolling Lanes
 AET = All Electronic Tolling





2018 Annual Average Daily Traffic

On Jane Addams Memorial Tollway, from Roselle Road to Devon Avenue

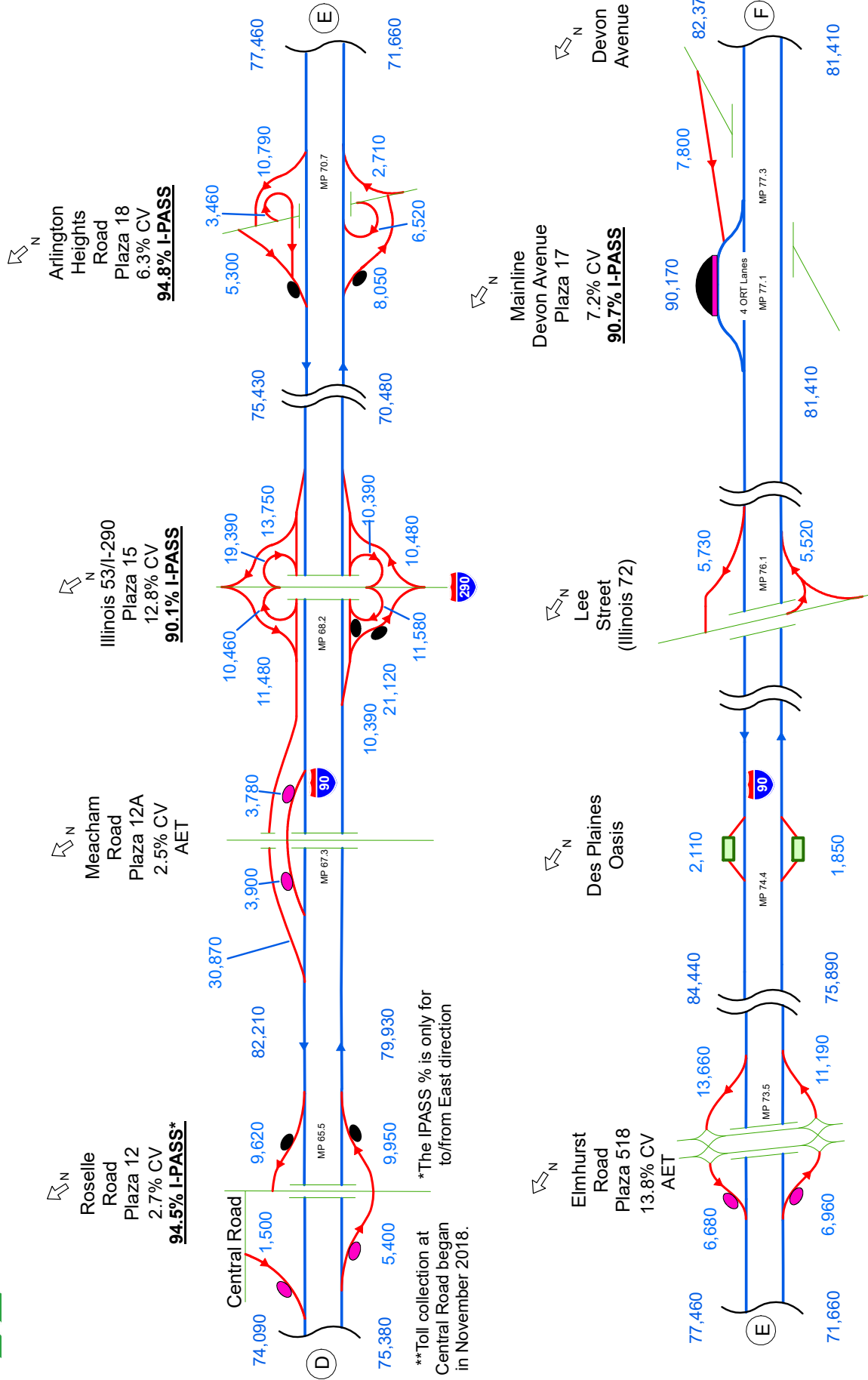

**Toll collection at Central Road began in November 2018.

*The IPASS % is only for to/from East direction

CV = Commercial Vehicles
 I-PASS = I-PASS Electronic Toll Collection
 ORT = Open Road Tolling Lanes
 AET = All Electronic Tolling





2018 Annual Average Daily Traffic

On Jane Addams Memorial Tollway, from Tri-State Tollway to Kennedy Expressway

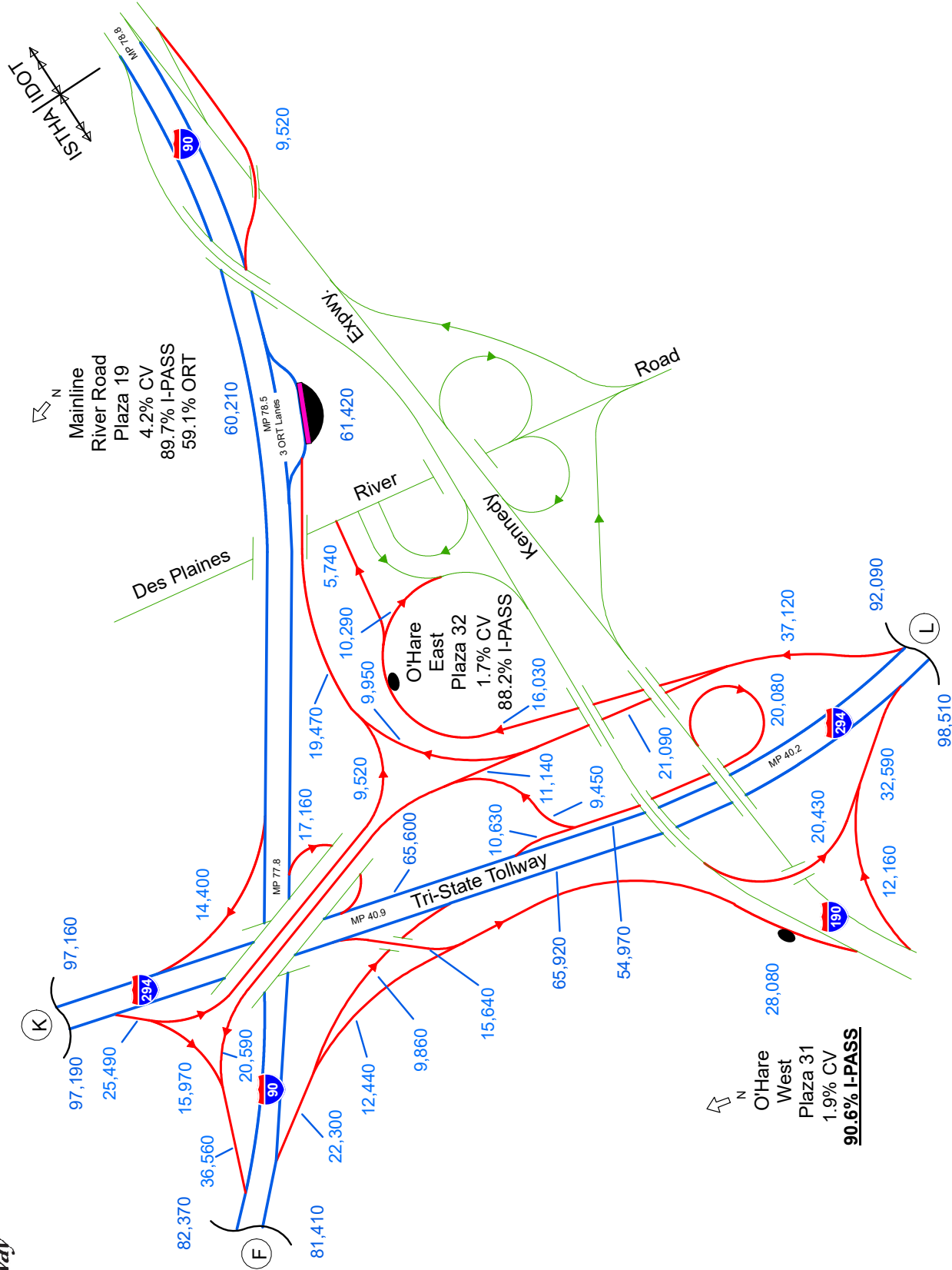

CV = Commercial Vehicles
 I-PASS = I-PASS Electronic Toll Collection
 ORT = Open Road Tolling Lanes
 AET = All Electronic Tolling





2018 Annual Average Daily Traffic

On Tri-State Tollway, from Russell Road to Lake Forest Oasis

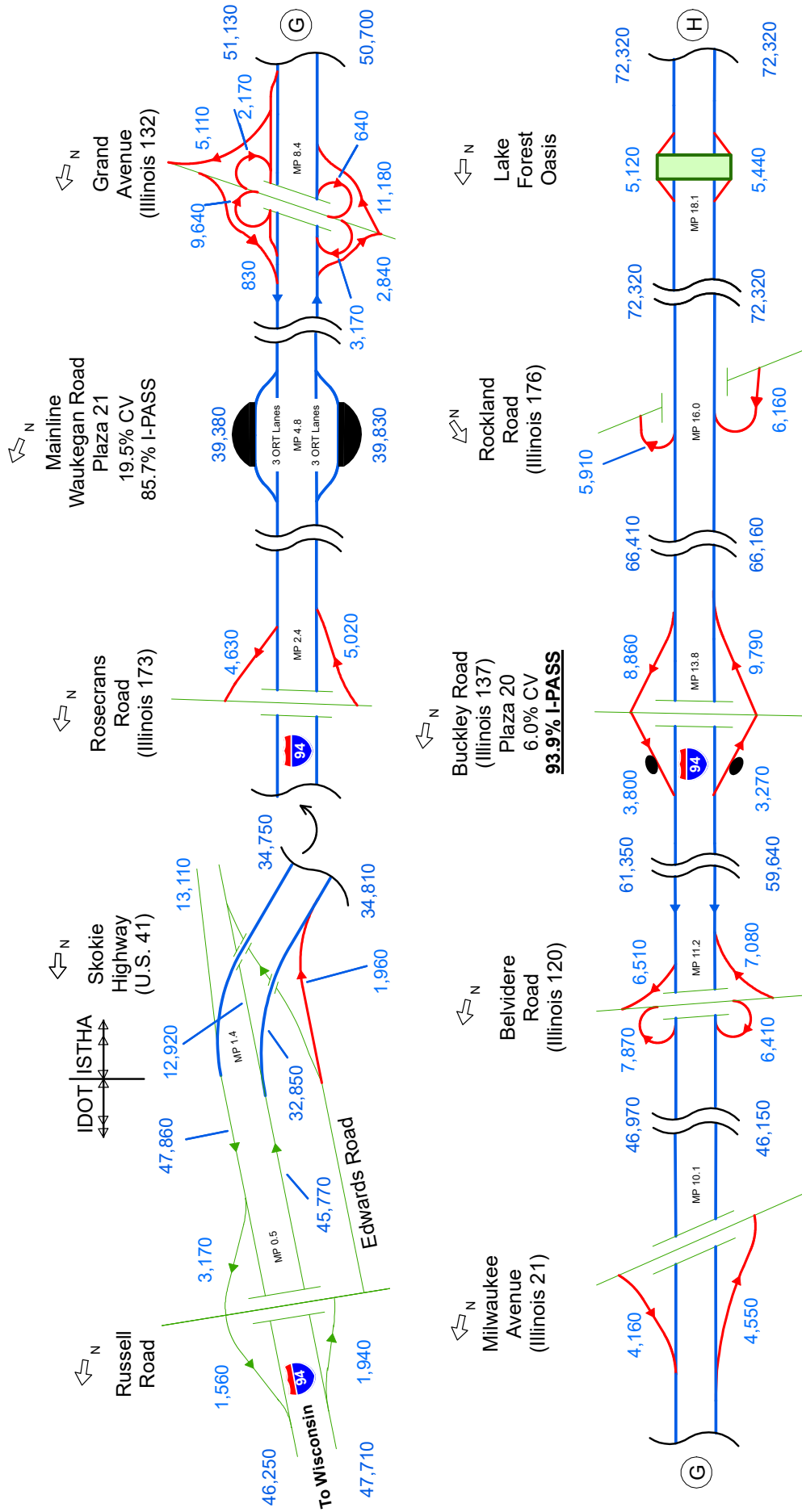

CV = Commercial Vehicles
 I-PASS = I-PASS Electronic Toll Collection
 ORT = Open Road Tolling Lanes
 AET = All Electronic Tolling





2018 Annual Average Daily Traffic

On Tri-State Tollway, from Town Line Road (Illinois 60) to Golf Road (Illinois 58) and Edens Spur

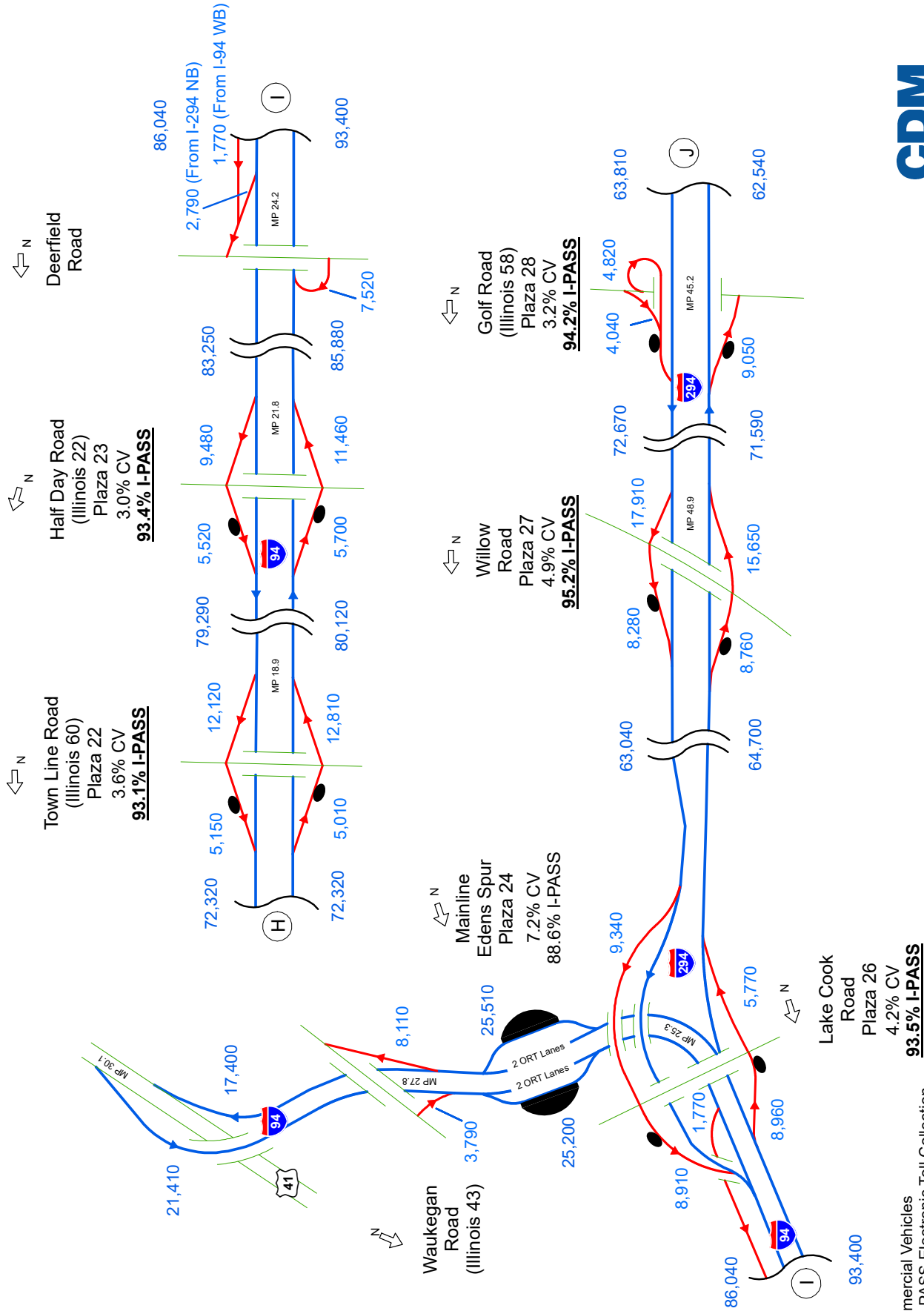

CV = Commercial Vehicles
 I-PASS = I-PASS Electronic Toll Collection
 ORT = Open Road Tolling Lanes
 AET = All Electronic Tolling





2018 Annual Average Daily Traffic

On Tri-State Tollway, from Dempster Street to O'Hare Oasis

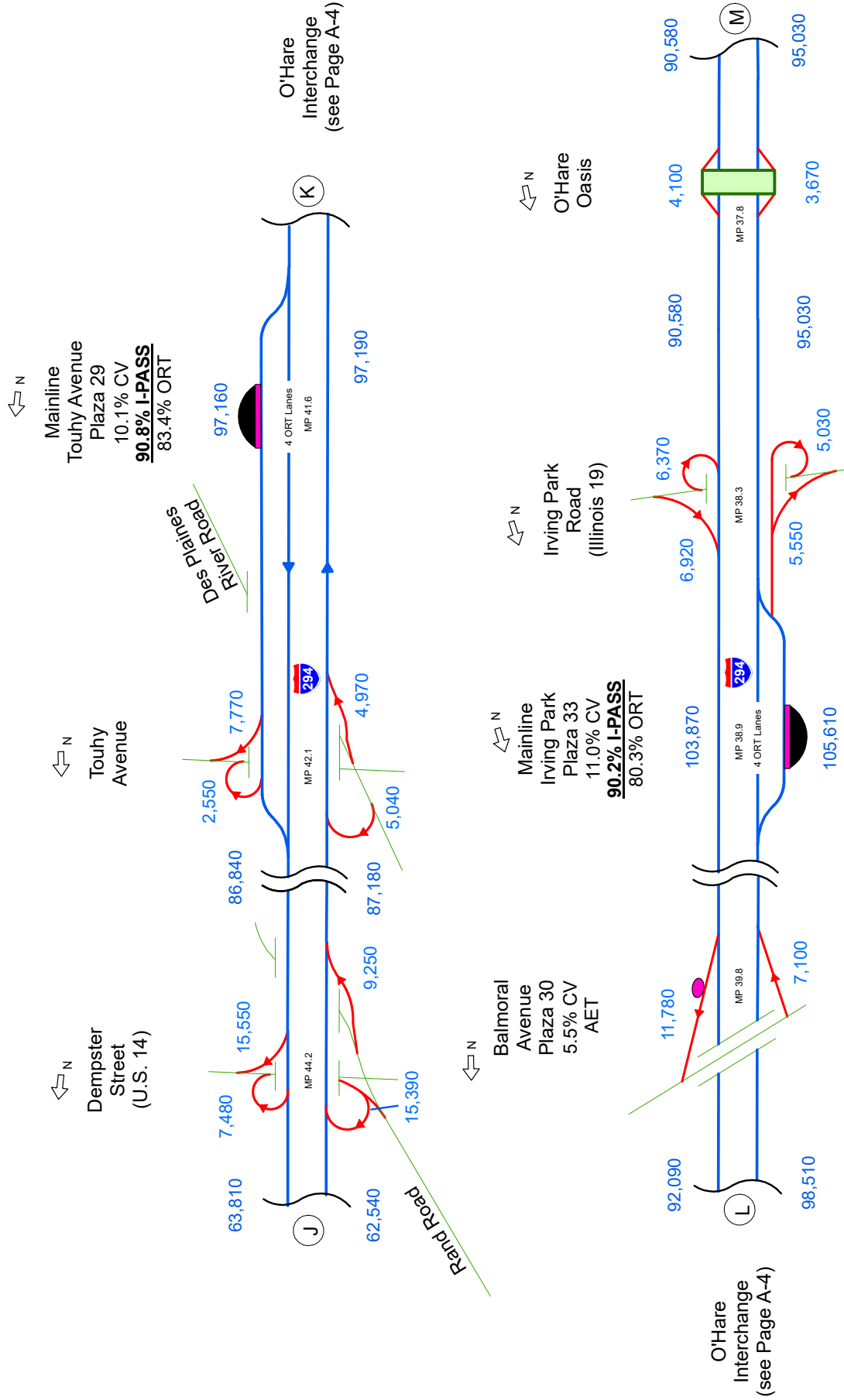

CV = Commercial Vehicles
 I-PASS = I-PASS Electronic Toll Collection
 ORT = Open Road Tolling Lanes
 AET = All Electronic Tolling





2018 Annual Average Daily Traffic

On Tri-State Tollway, from North Avenue / Lake Street to Reagan Memorial Tollway (I-88)

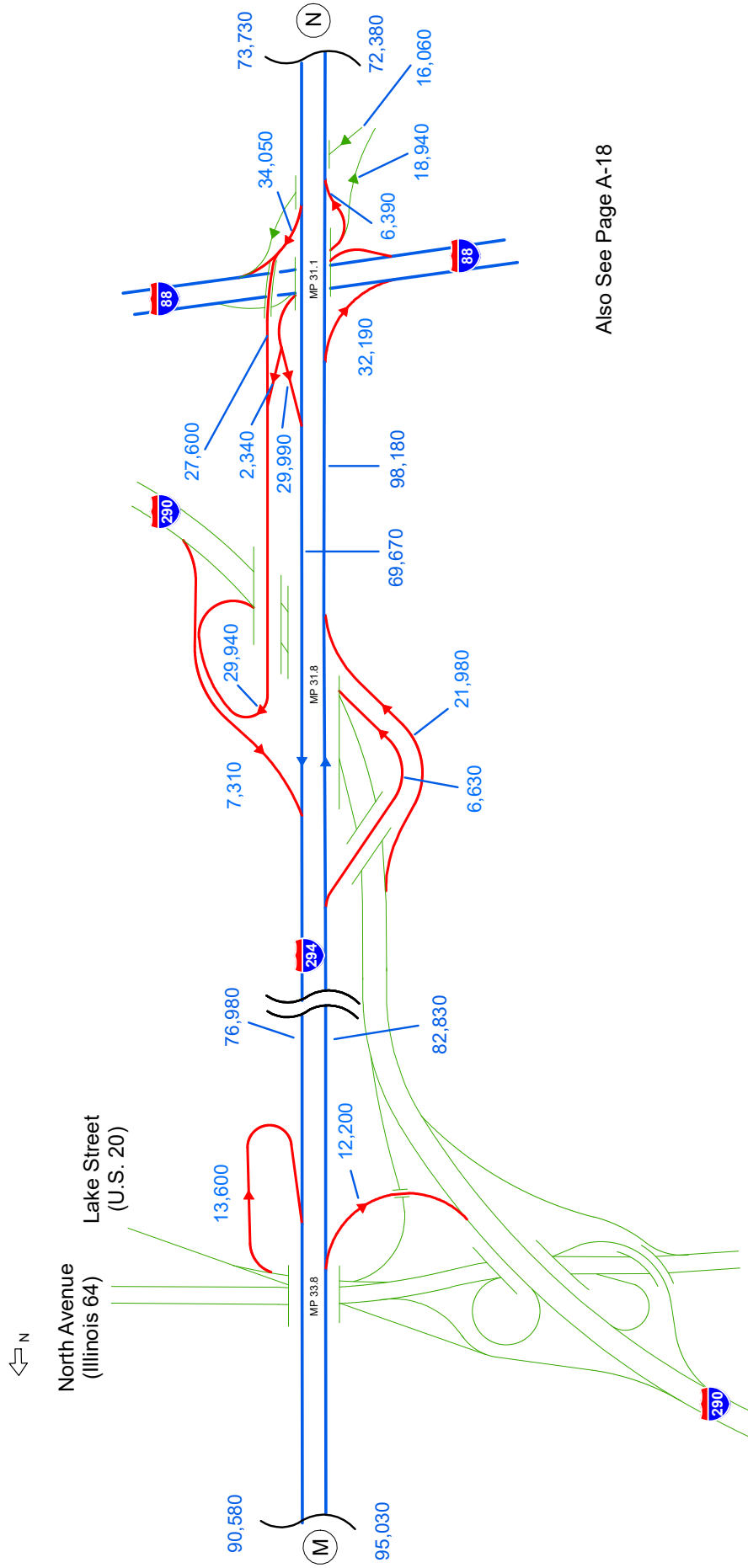

Also See Page A-18

CV = Commercial Vehicles
 I-PASS = I-PASS Electronic Toll Collection
 ORT = Open Road Tolling Lanes
 AET = All Electronic Tolling





2018 Annual Average Daily Traffic

On Tri-State Tollway, from Roosevelt Road to Hinsdale Oasis

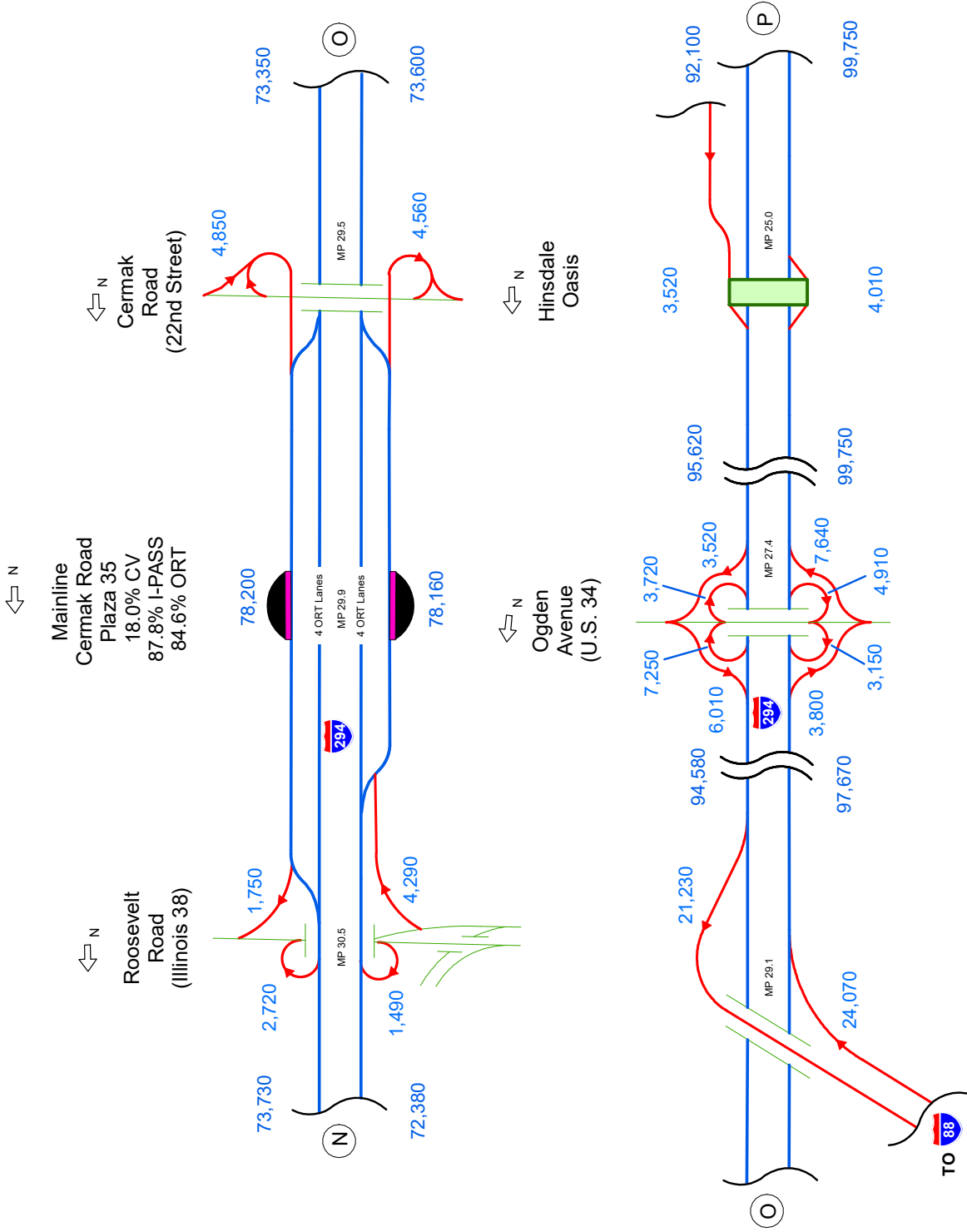

Also See Page A-17

CV = Commercial Vehicles
 I-PASS = I-PASS Electronic Toll Collection
 ORT = Open Road Tolling Lanes
 AET = All Electronic Tolling





2018 Annual Average Daily Traffic

On Tri-State Tollway, from Joliet Road (Plaza 37) to Willow Springs Road (Plaza 34)

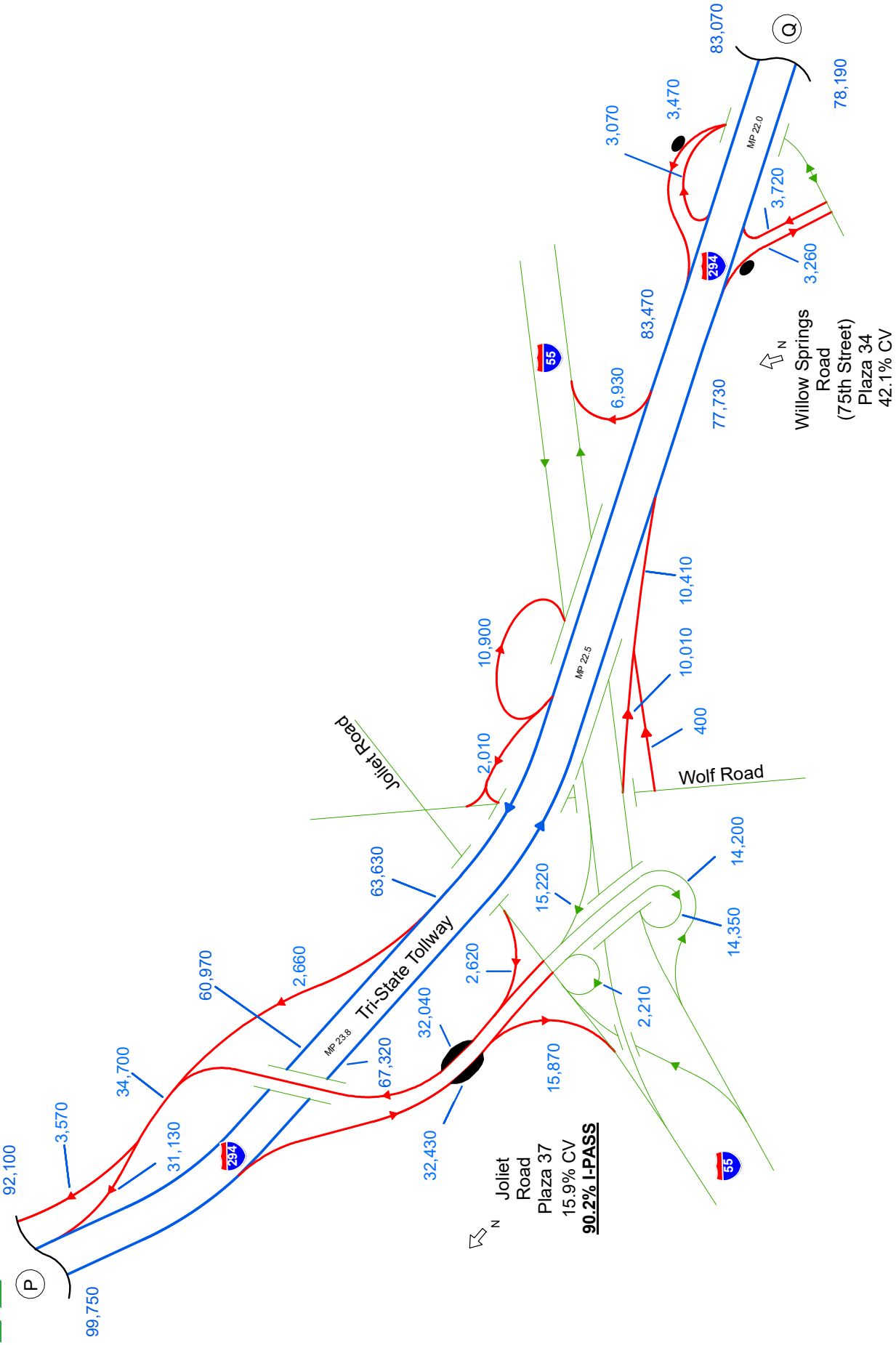

CV = Commercial Vehicles
 I-PASS = I-PASS Electronic Toll Collection
 ORT = Open Road Tolling Lanes
 AET = All Electronic Tolling





2018 Annual Average Daily Traffic

On Tri-State Tollway, from Archer / Lagrange to 147th Street (Plaza 42) / I-57

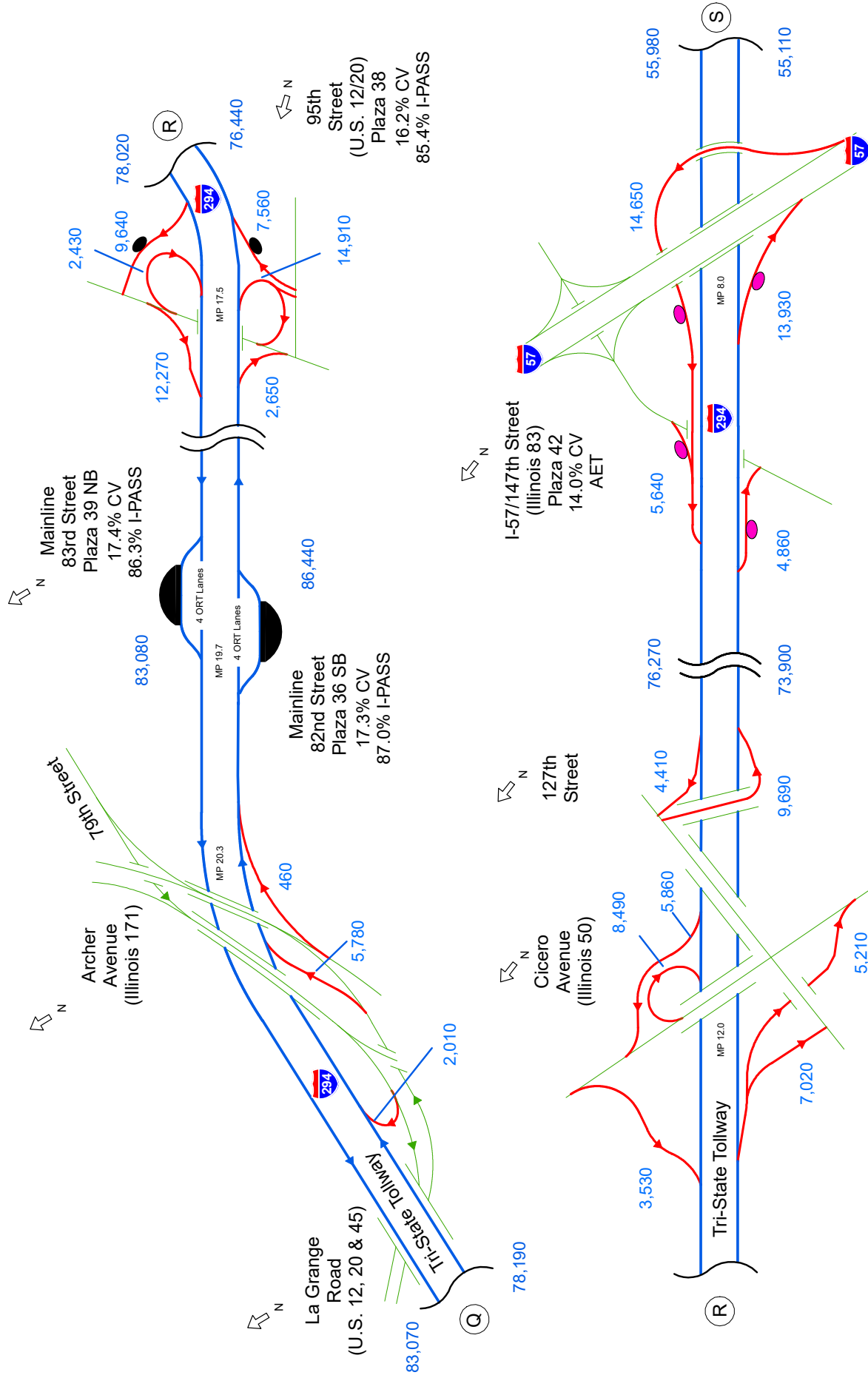

CV = Commercial Vehicles
 I-PASS = I-PASS Electronic Toll Collection
 ORT = Open Road Tolling Lanes
 AET = All Electronic Tolling





2018 Annual Average Daily Traffic

On Tri-State Tollway, from 159th Street (Plaza 40) to Bishop Ford / Kingery Expressway

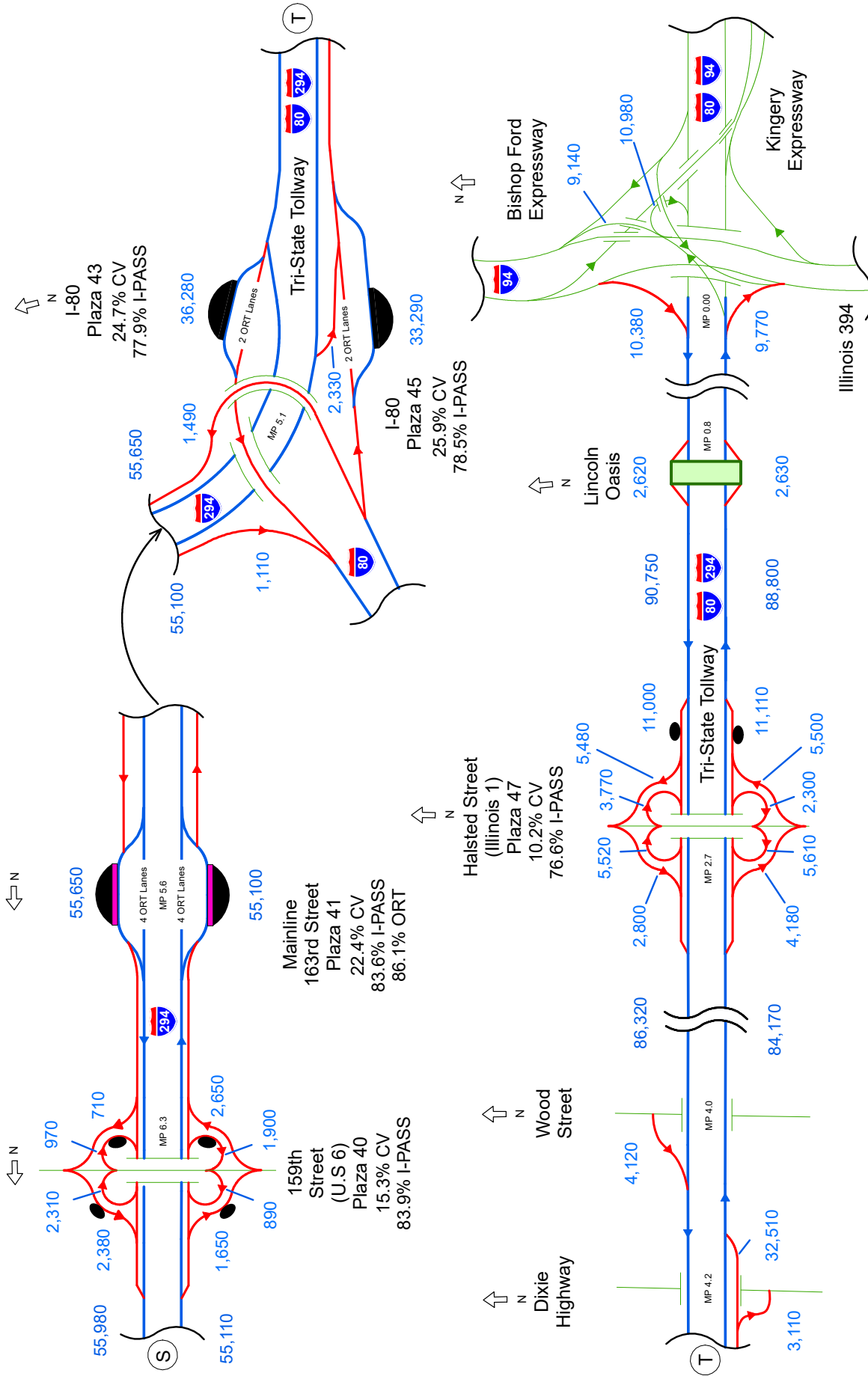

CV = Commercial Vehicles
I-PASS = I-PASS Electronic Toll Collection
ORT = Open Road Tolling Lanes
AET = All Electronic Tolling

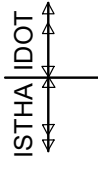



2018 Annual Average Daily Traffic

On Reagan Memorial Tollway, from Illinois 26 to Orchard Road

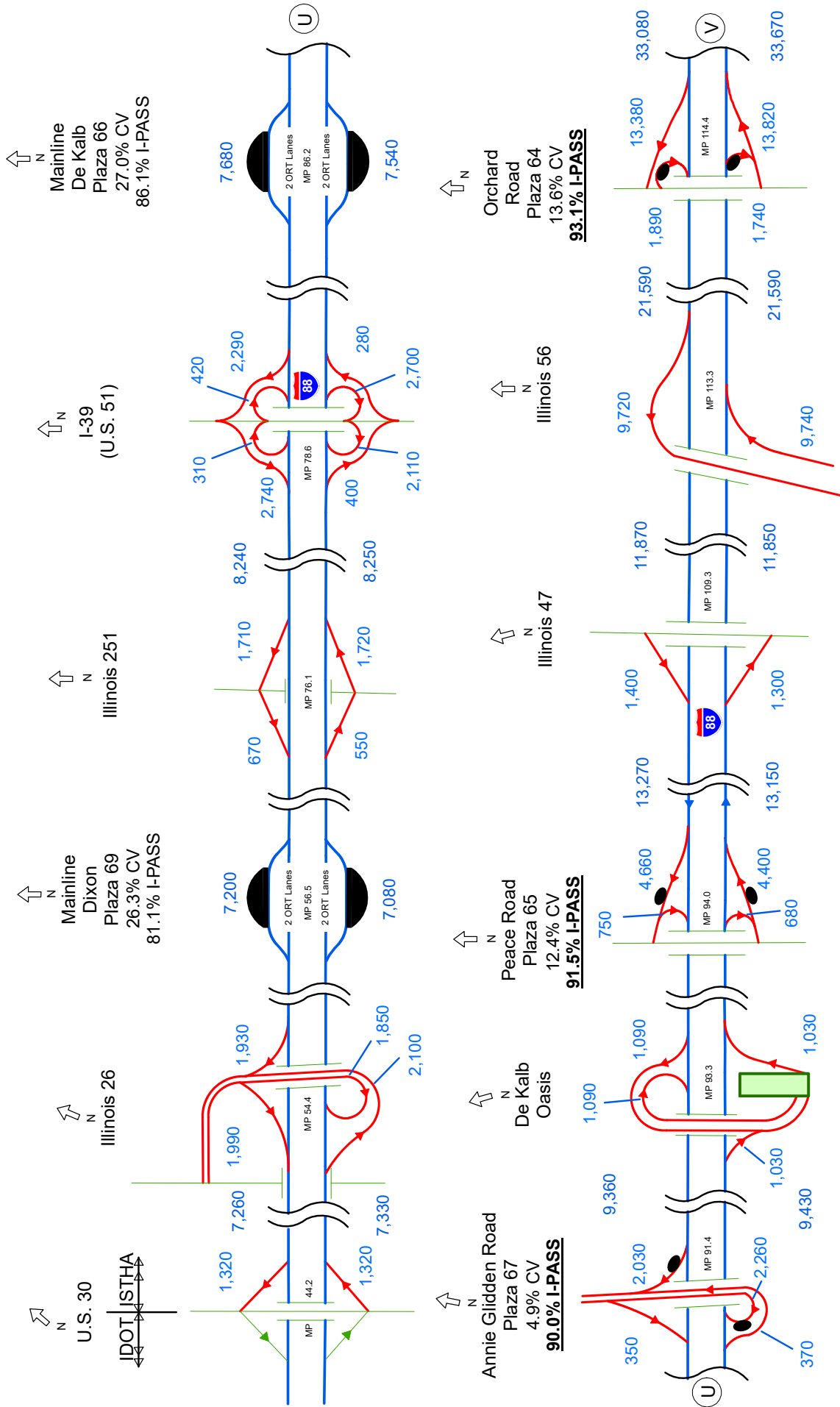

CV = Commercial Vehicles
 I-PASS = I-PASS Electronic Toll Collection
 ORT = Open Road Tolling Lanes
 AET = All Electronic Tolling





2018 Annual Average Daily Traffic

On Reagan Memorial Tollway, from Illinois 31 to Illinois 53

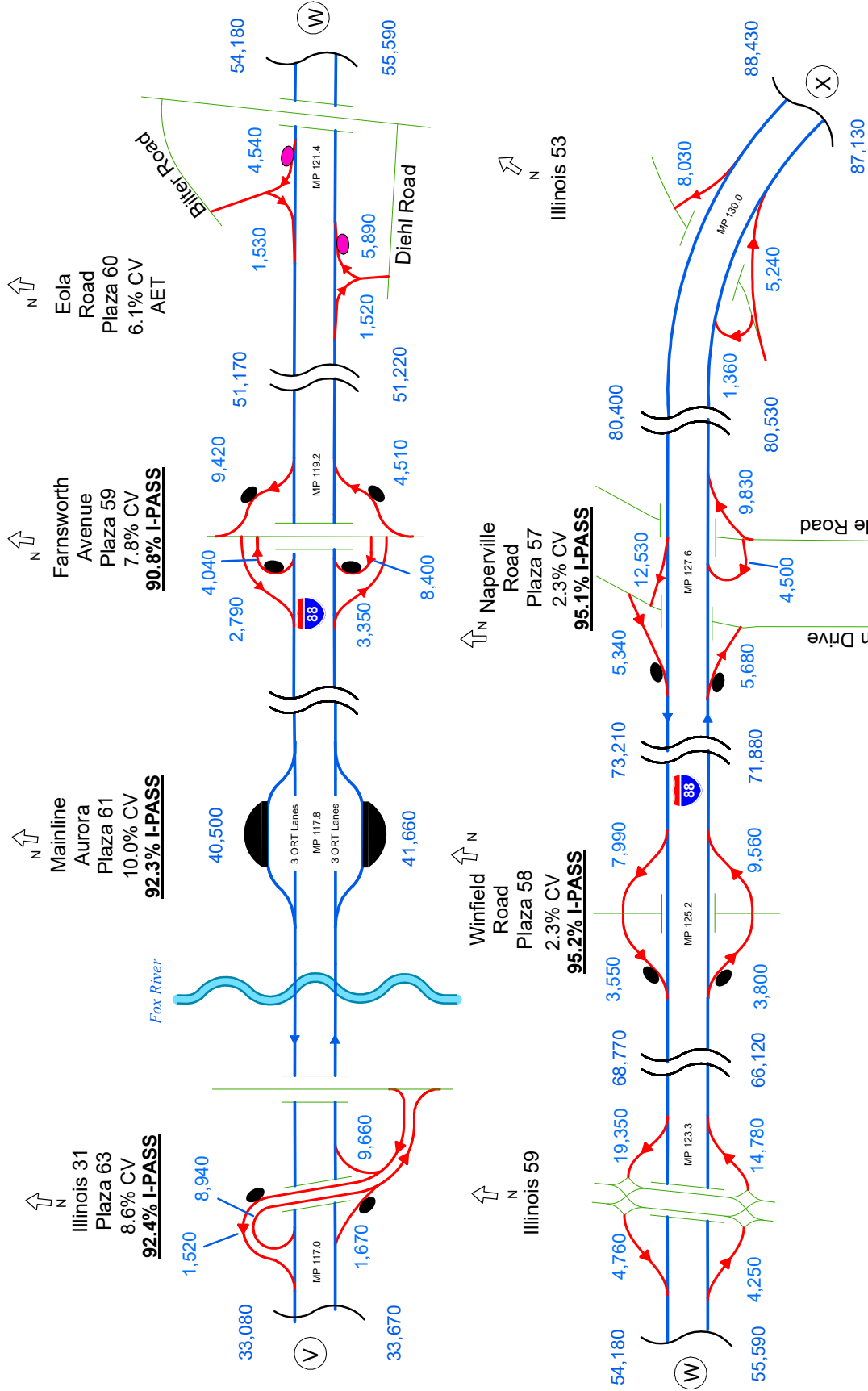

CV = Commercial Vehicles
 I-PASS = I-PASS Electronic Toll Collection
 ORT = Open Road Tolling Lanes
 AET = All Electronic Tolling





2018 Annual Average Daily Traffic

On Reagan Memorial Tollway, Veterans Memorial Tollway West Interchange

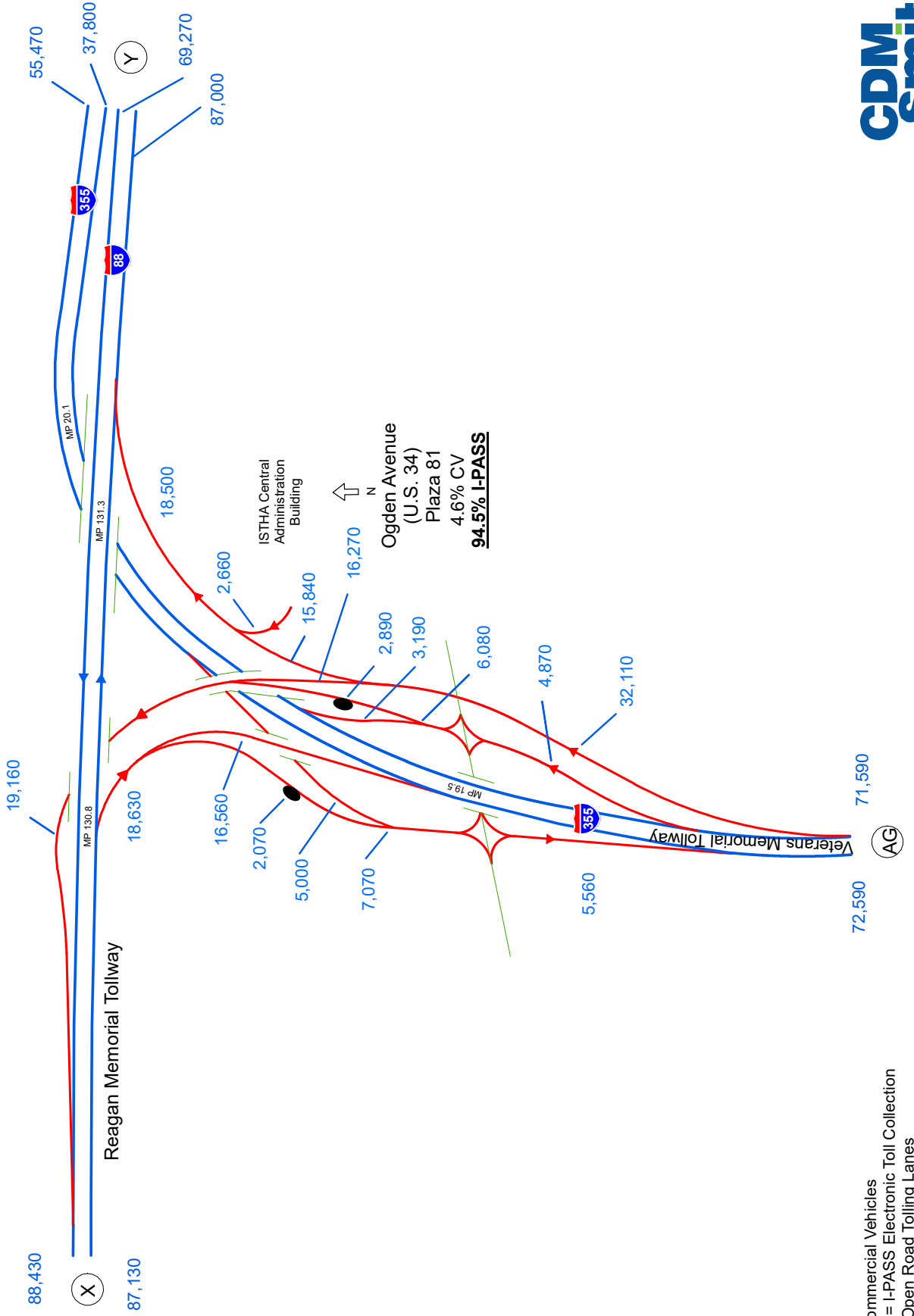

CV = Commercial Vehicles
 I-PASS = I-PASS Electronic Toll Collection
 ORT = Open Road Tolling Lanes
 AET = All Electronic Tolling





2018 Annual Average Daily Traffic

On Reagan Memorial Tollway, Veterans Memorial Tollway East Interchange

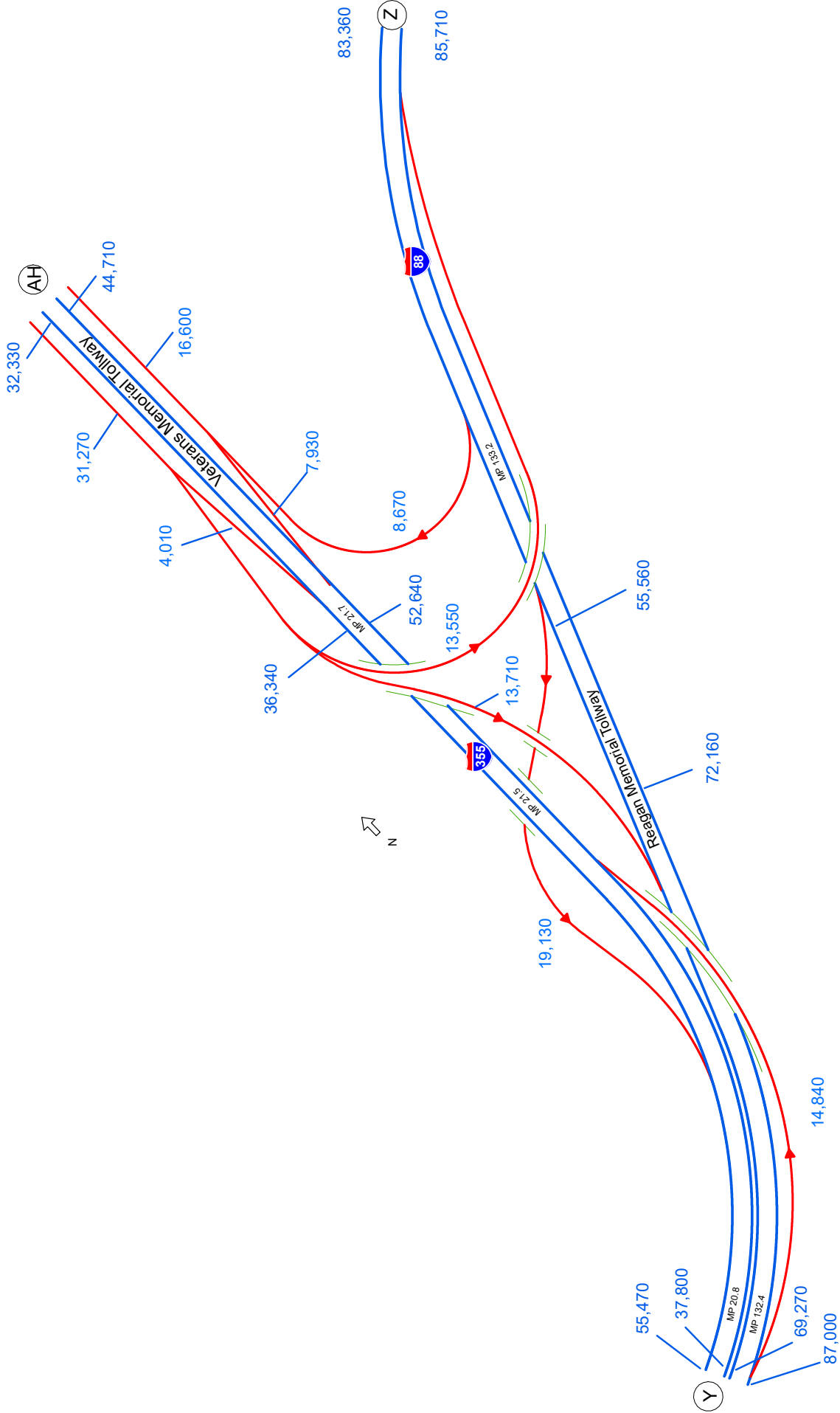

CV = Commercial Vehicles
 I-PASS = I-PASS Electronic Toll Collection
 ORT = Open Road Tolling Lanes
 AET = All Electronic Tolling





2018 Annual Average Daily Traffic

On Reagan Memorial Tollway, from Highland Avenue to Harger Road

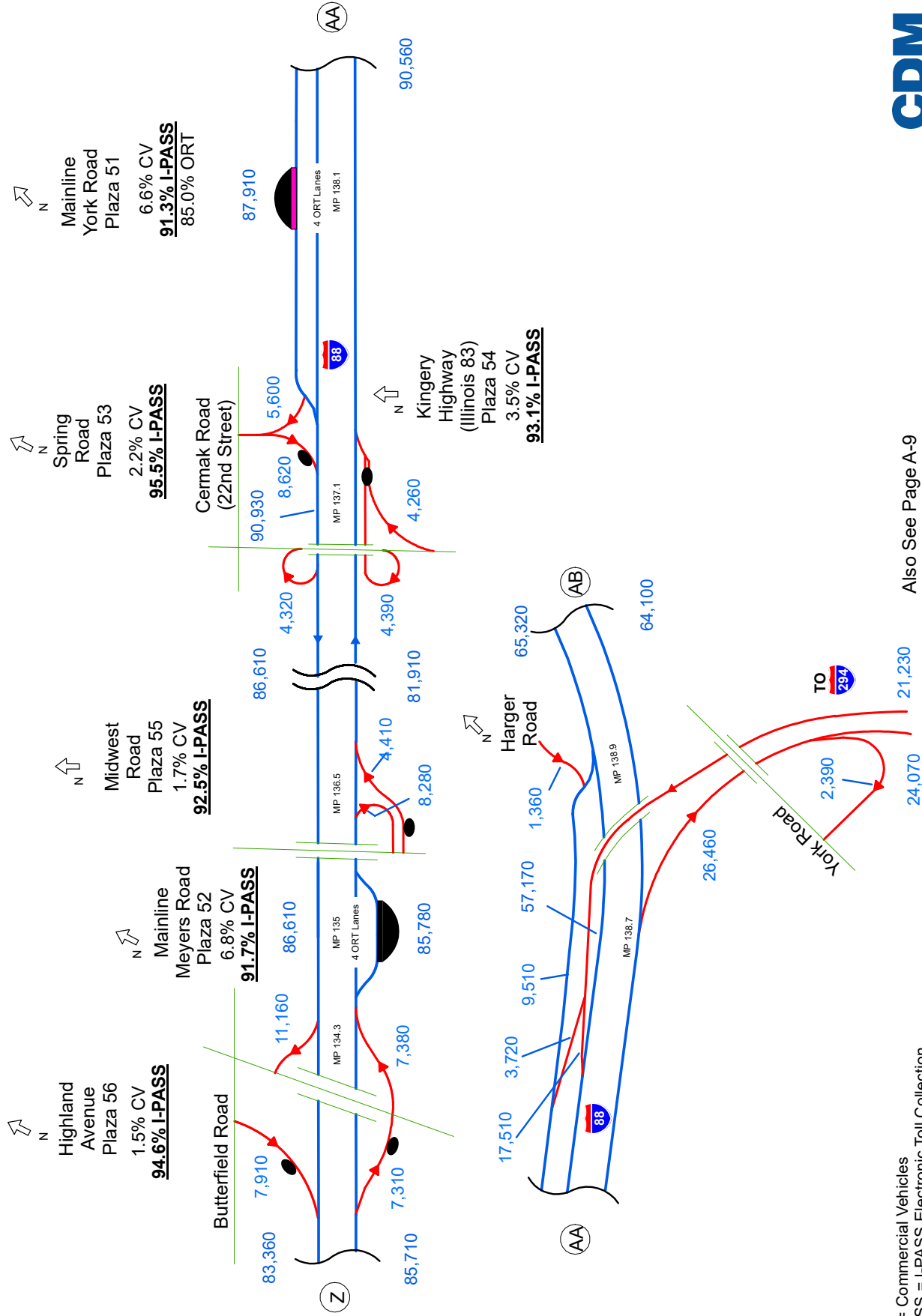

CV = Commercial Vehicles
 I-PASS = I-PASS Electronic Toll Collection
 ORT = Open Road Tolling Lanes
 AET = All Electronic Tolling

Also See Page A-9





2018 Annual Average Daily Traffic

On Reagan Memorial Tollway, from Roosevelt Road to Eisenhower Expressway (I-290)

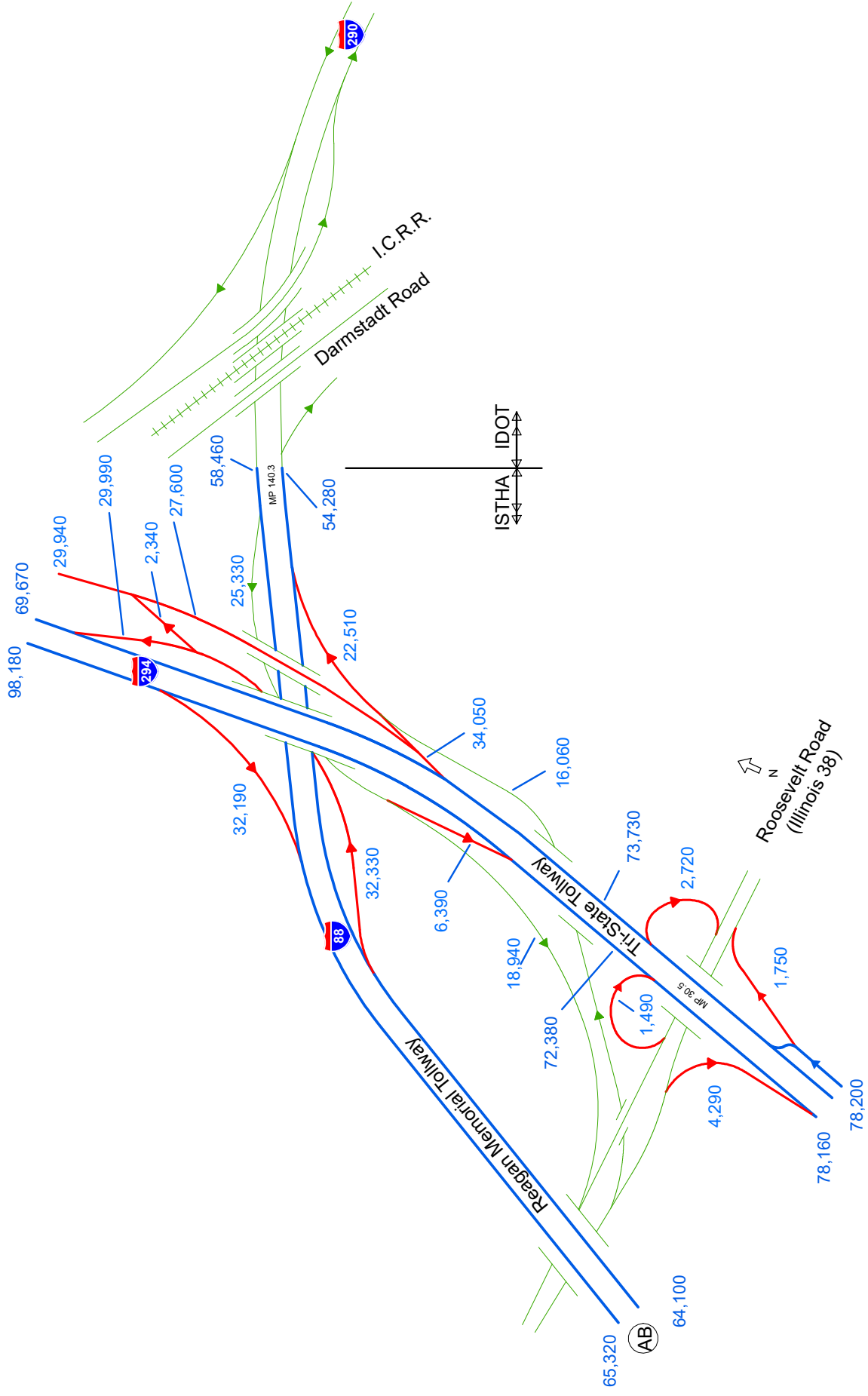

CV = Commercial Vehicles
 I-PASS = I-PASS Electronic Toll Collection
 ORT = Open Road Tolling Lanes
 AET = All Electronic Tolling





2018 Annual Average Daily Traffic

On Veterans Memorial Tollway, from Interstate 80 to 127th Street

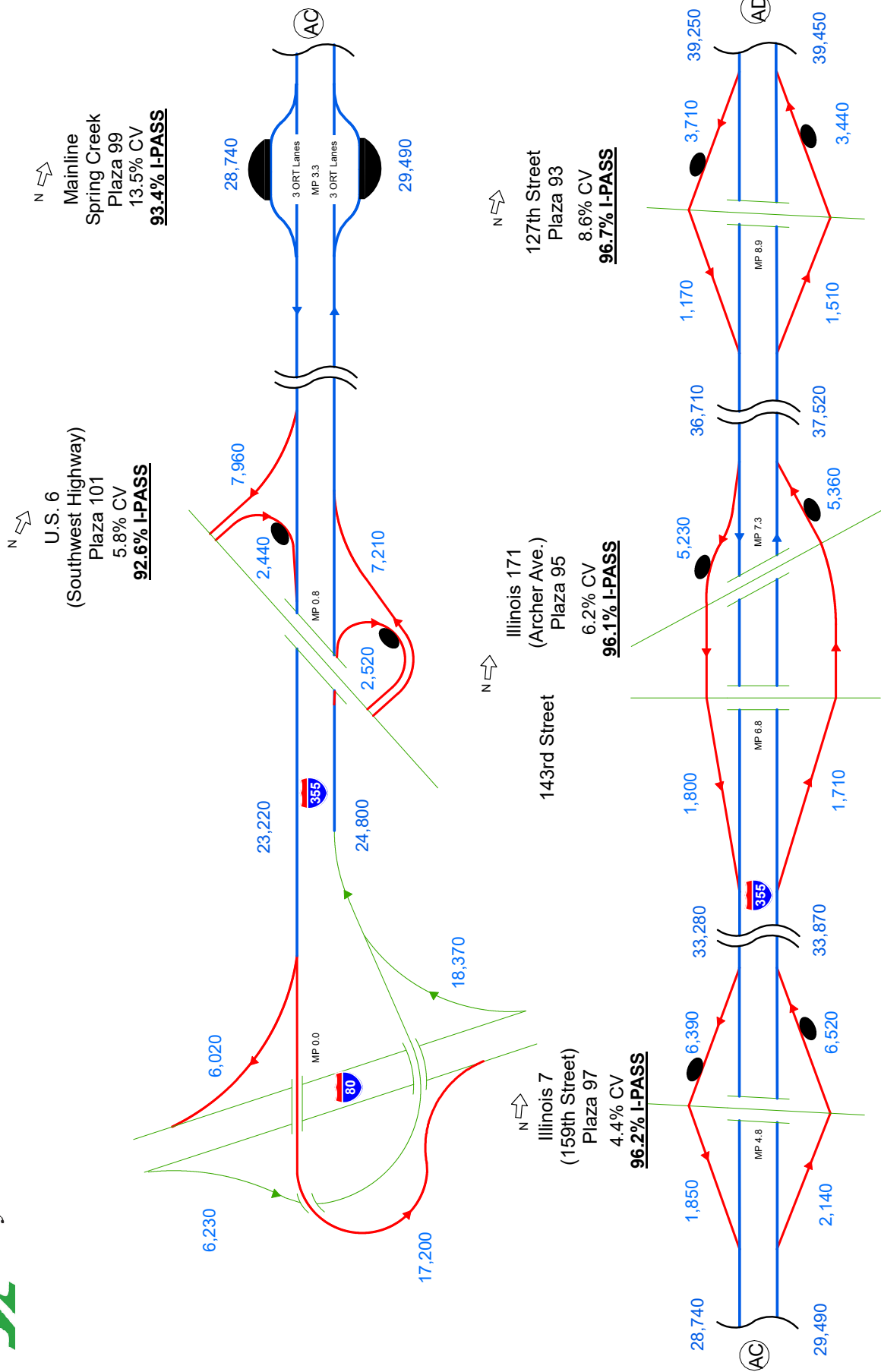

CV = Commercial Vehicles
 I-PASS = I-PASS Electronic Toll Collection
 ORT = Open Road Tolling Lanes
 AET = All Electronic Tolling





2018 Annual Average Daily Traffic

On Veterans Memorial Tollway, At Interstate 55

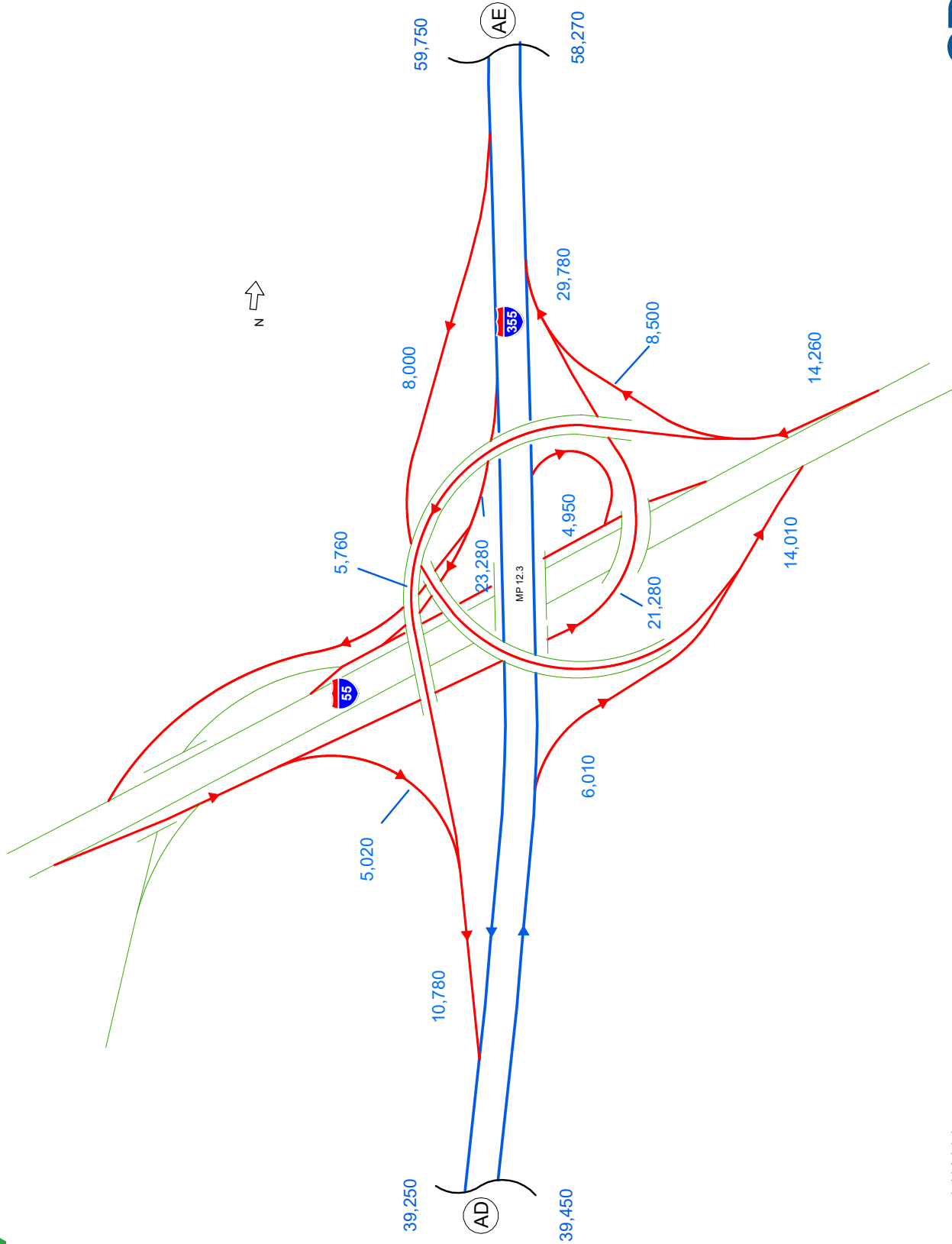

CV = Commercial Vehicles
I-PASS = I-PASS Electronic Toll Collection
ORT = Open Road Tolling Lanes
AET = All Electronic Tolling





2018 Annual Average Daily Traffic

On Veterans Memorial Tollway, from Boughton Road to Maple Avenue

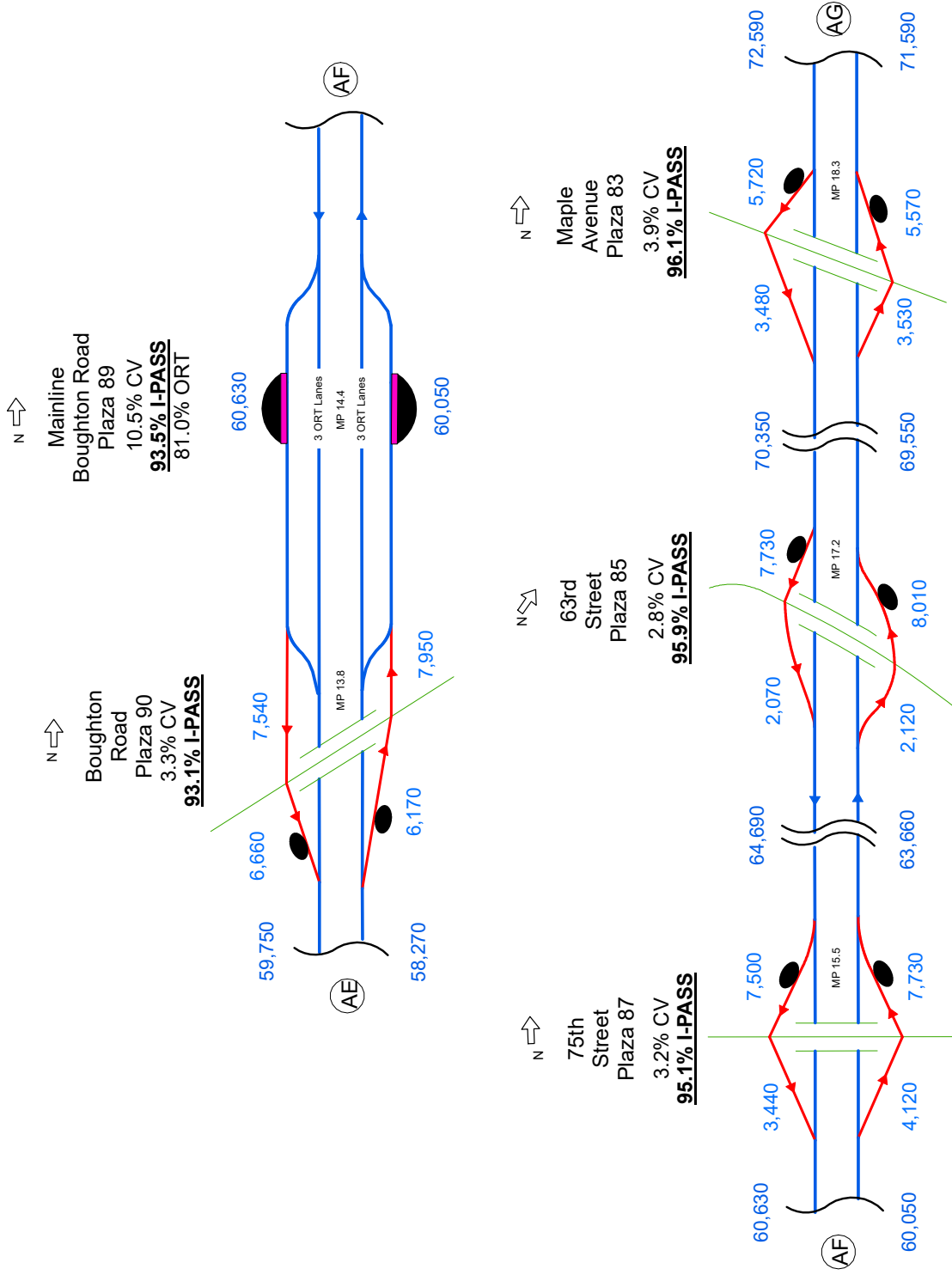

CV = Commercial Vehicles
 I-PASS = I-PASS Electronic Toll Collection
 ORT = Open Road Tolling Lanes
 AET = All Electronic Tolling





2018 Annual Average Daily Traffic

On Veterans Memorial Tollway, from Ogden Avenue / West Interchange to Army Trail Road

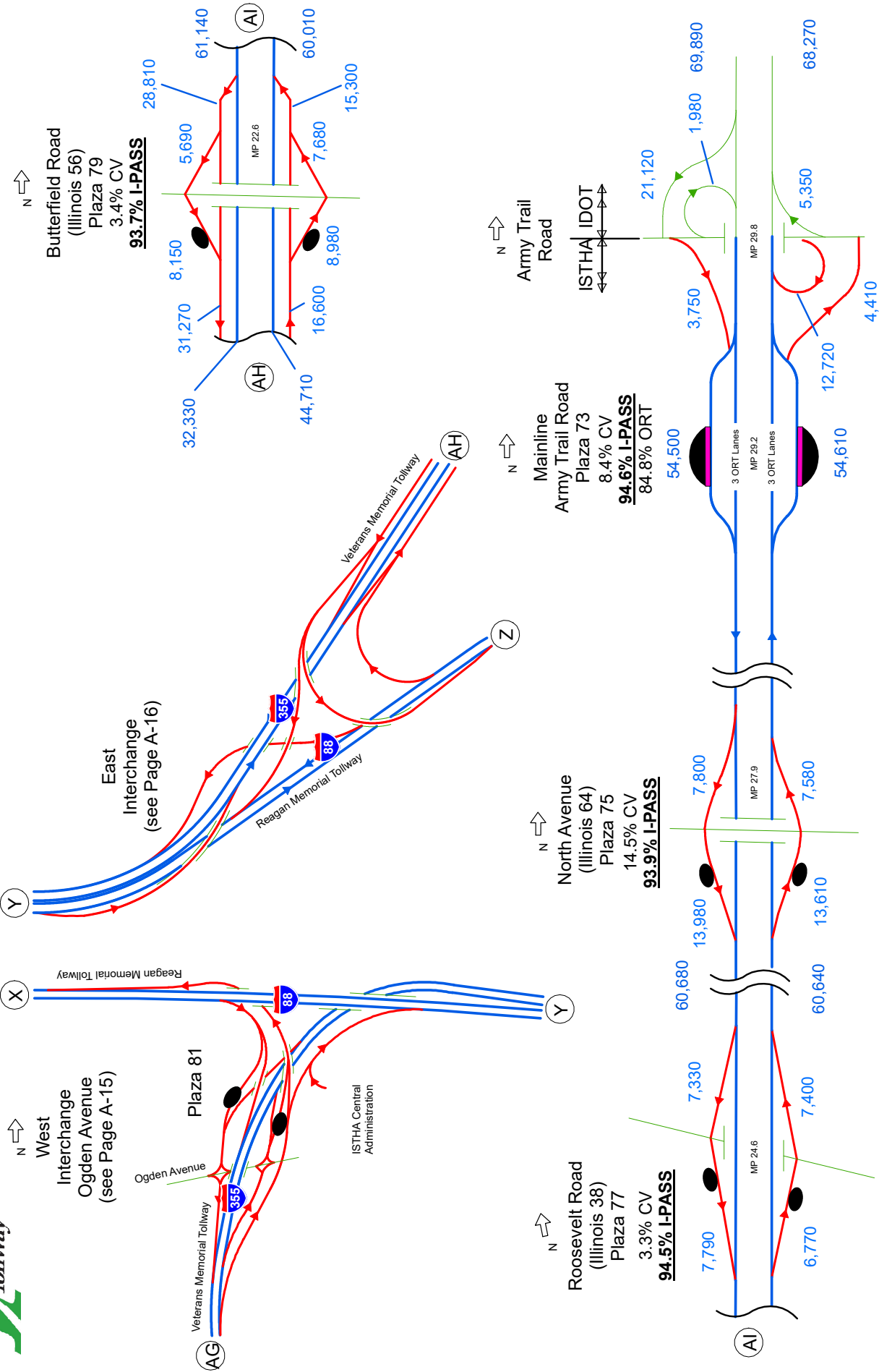

CV = Commercial Vehicles
 I-PASS = I-PASS Electronic Toll Collection
 ORT = Open Road Tolling Lanes
 AET = All Electronic Tolling





2018 Annual Average Daily Traffic

On IL 390, from Lake Street to Plum Grove Road (Plaza 326)

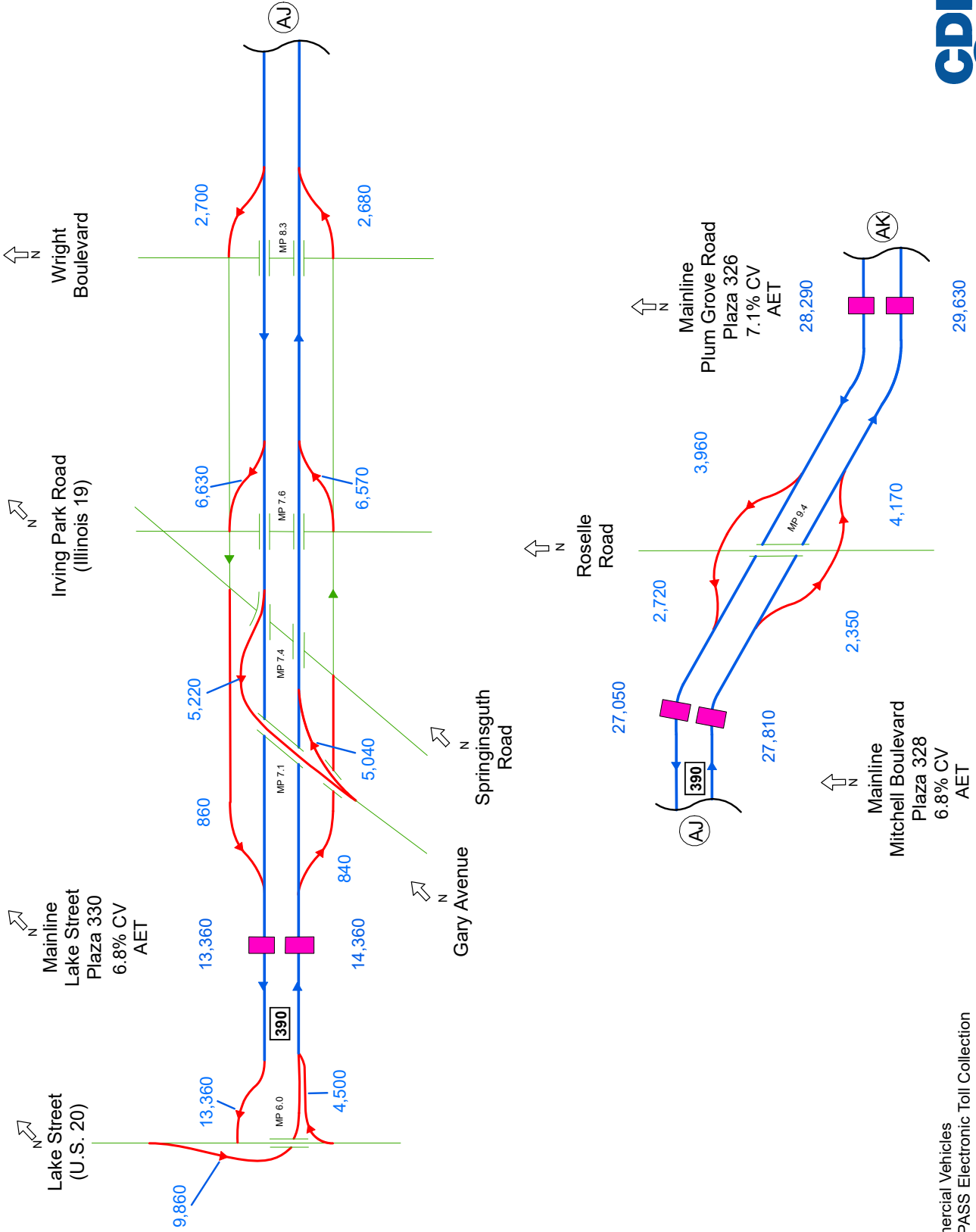

CV = Commercial Vehicles
 I-PASS = I-PASS Electronic Toll Collection
 ORT = Open Road Tolling Lanes
 AET = All Electronic Tolling





2018 Annual Average Daily Traffic

On IL 390, from Plum Grove Road (Plaza 326) to Busse Road (Illinois 83)

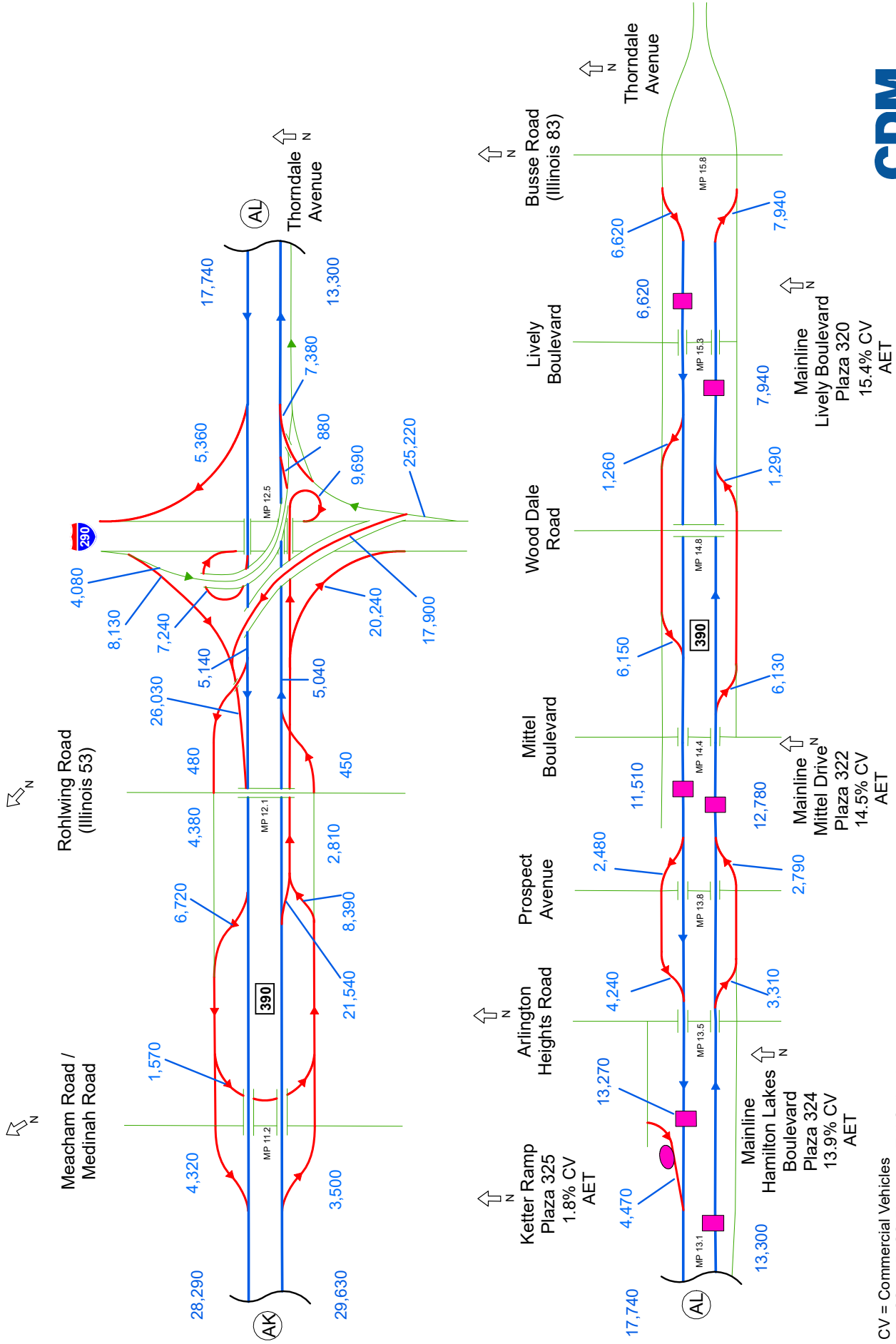

CV = Commercial Vehicles
 I-PASS = I-PASS Electronic Toll Collection
 ORT = Open Road Tolling Lanes
 AET = All Electronic Tolling



A stylized graphic of a road on the left side of the page, curving from the top left towards the bottom right. The road is depicted with a green surface and white dashed and solid lines representing lane markings. The background is a gradient of blue and green.

Appendix B

**2018 Systemwide
A.M. and P.M. Peak Hour
Traffic Schematics**



2018 A.M. & P.M. Peak Hour Traffic

On Jane Addams Memorial Tollway, from Rockton Road to Marengo (Plaza 7)

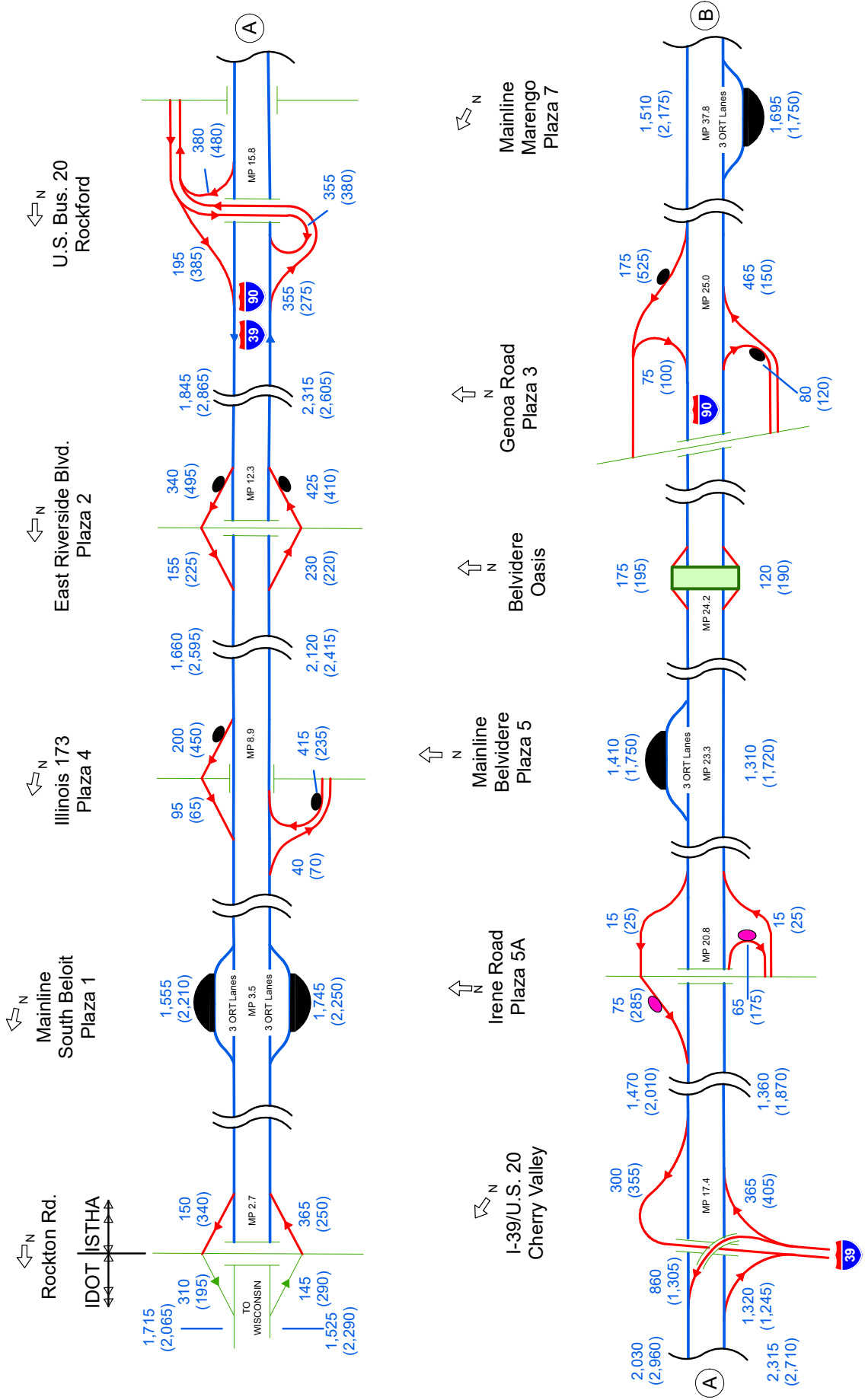

Note:
 The 2018 AM & PM peak-hour volumes are defined as the 85th Percentile volumes occurring in the 6:00 to 8:00 AM and the 4:00 to 6:00 PM periods respectively. Peak-hour volumes are calculated from Monday through Thursday hourly traffic volume data only, and exclude holidays.

**** = A.M. Peak
 (*, ***) = P.M. Peak





2018 A.M. & P.M. Peak Hour Traffic

On Jane Addams Memorial Tollway, from U.S. 20, Marengo to Barrington Road

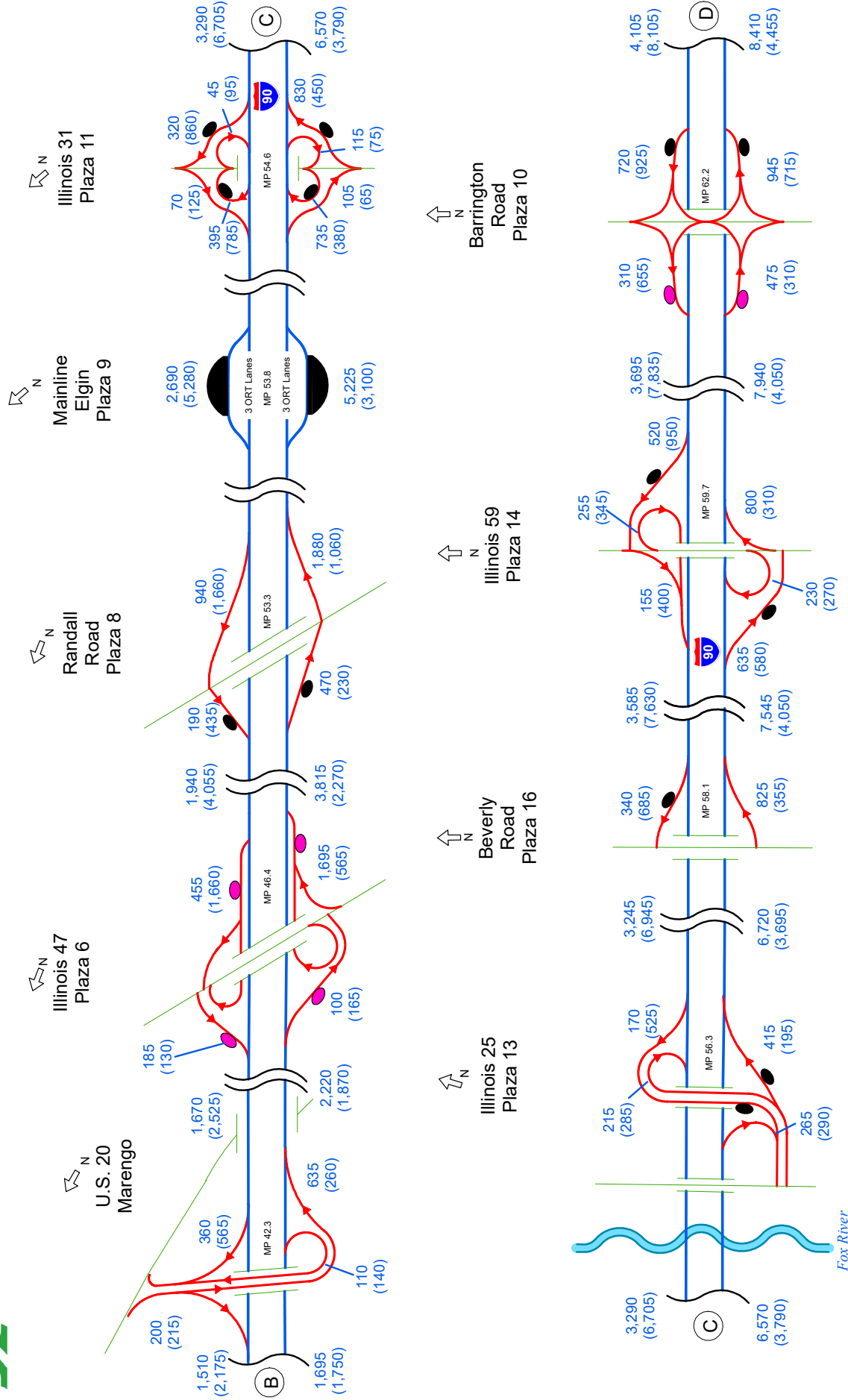

Note:
The 2018 AM & PM peak-hour volumes are defined as the 85th Percentile volumes occurring in the 6:00 to 8:00 AM and the 4:00 to 6:00 PM periods respectively. Peak-hour volumes are calculated from Monday through Thursday hourly traffic volume data only, and exclude holidays.

*** = A.M. Peak
(*, **) = P.M. Peak





2018 A.M. & P.M. Peak Hour Traffic

On Jane Addams Memorial Tollway, from Roselle Road to Devon Avenue

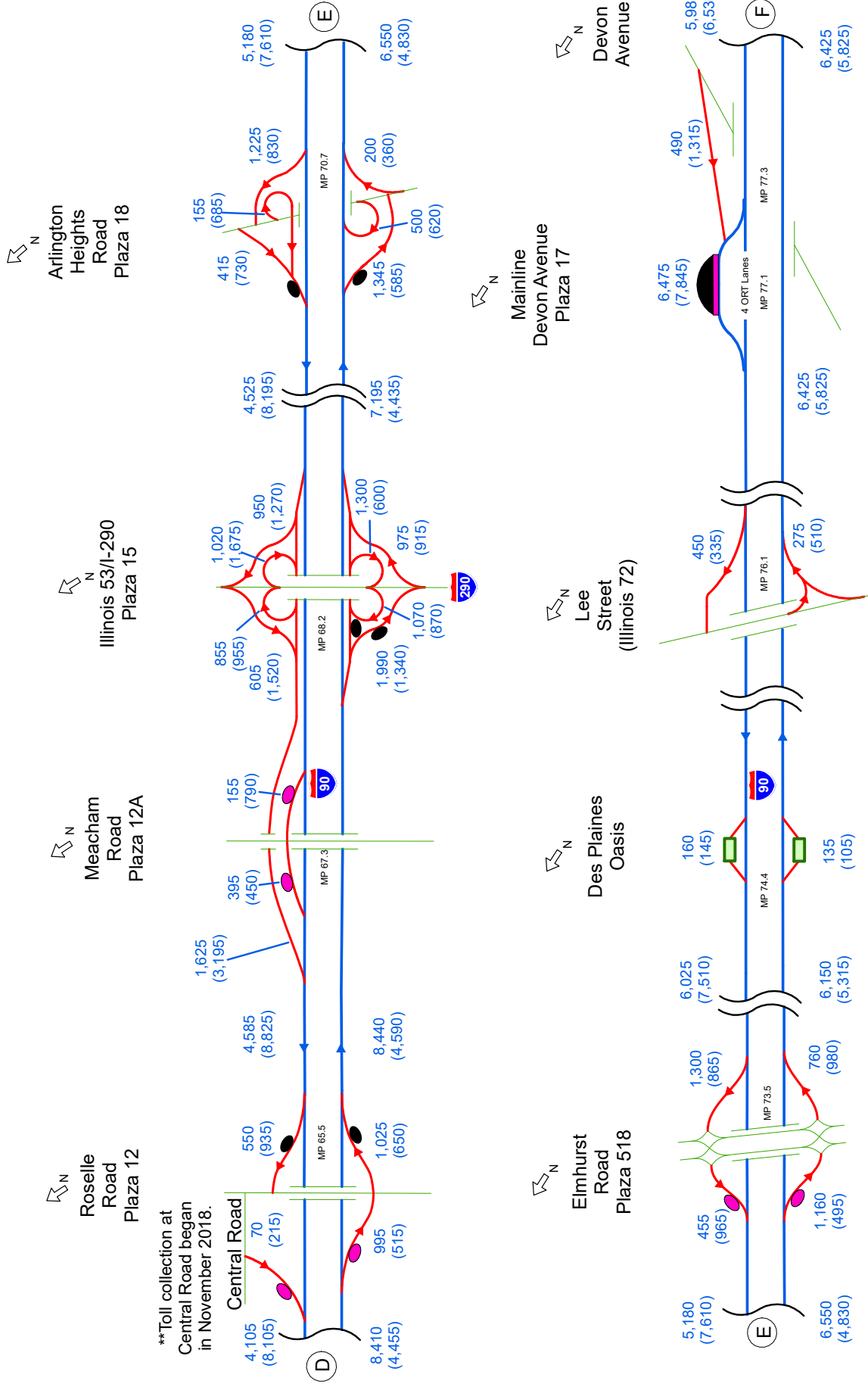

Note:
 The 2018 AM & PM peak-hour volumes are defined as the 85th Percentile volumes occurring in the 6:00 to 8:00 AM and the 4:00 to 6:00 PM periods respectively. Peak-hour volumes are calculated from Monday through Thursday hourly traffic volume data only, and exclude holidays.

* ** = A.M. Peak
 (*, **) = P.M. Peak





2018 A.M. & P.M. Peak Hour Traffic

On Jane Addams Memorial Tollway, from Tri-State Tollway to Kennedy Expressway

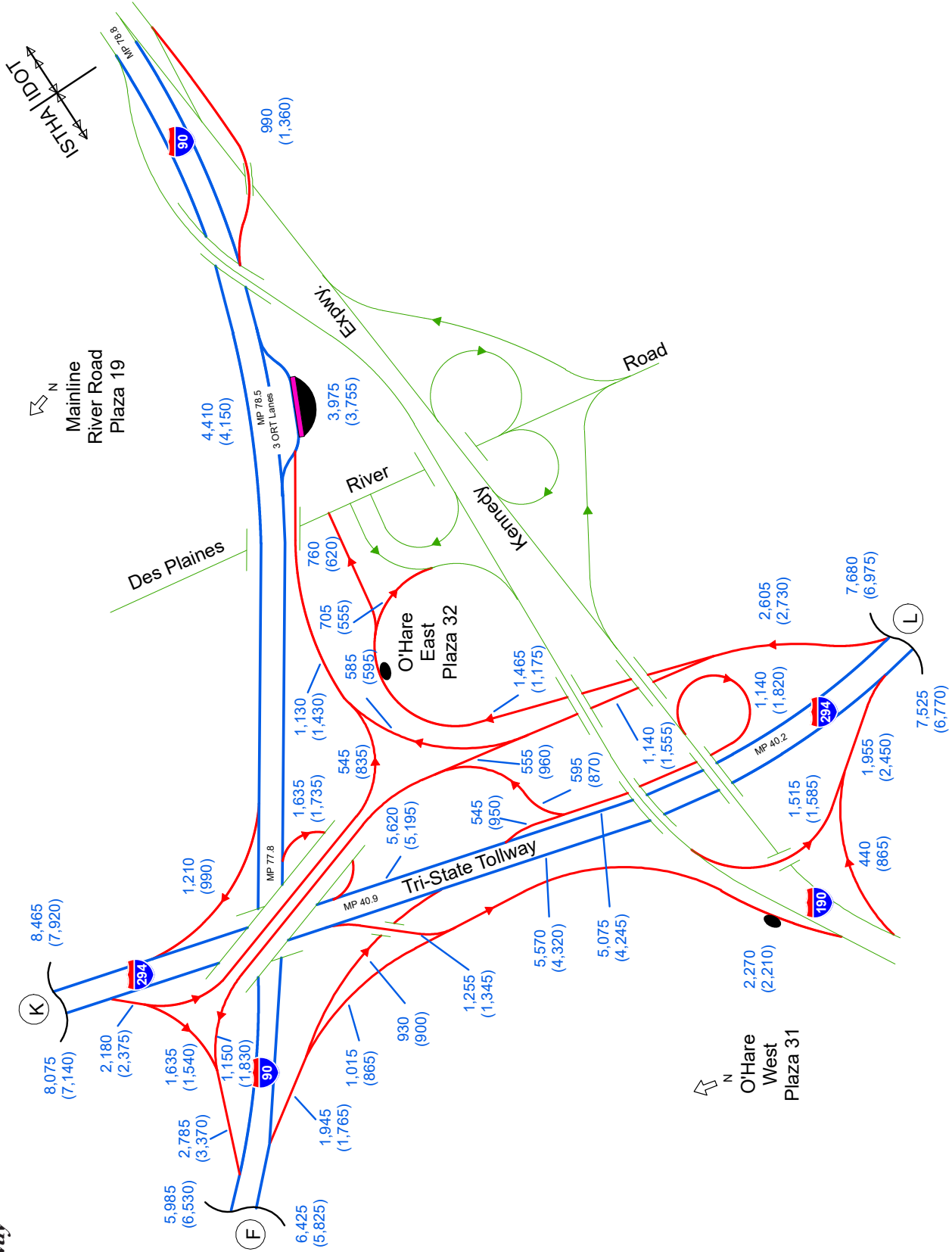

Note:
 The 2018 AM & PM peak-hour volumes are defined as the 85th Percentile volumes occurring in the 6:00 to 8:00 AM and the 4:00 to 6:00 PM periods respectively. Peak-hour volumes are calculated from Monday through Thursday hourly traffic volume data only, and exclude holidays.

**** = A.M. Peak
 (*, ****) = P.M. Peak





2018 A.M. & P.M. Peak Hour Traffic

On Tri-State Tollway, from Russell Road to Lake Forest Oasis

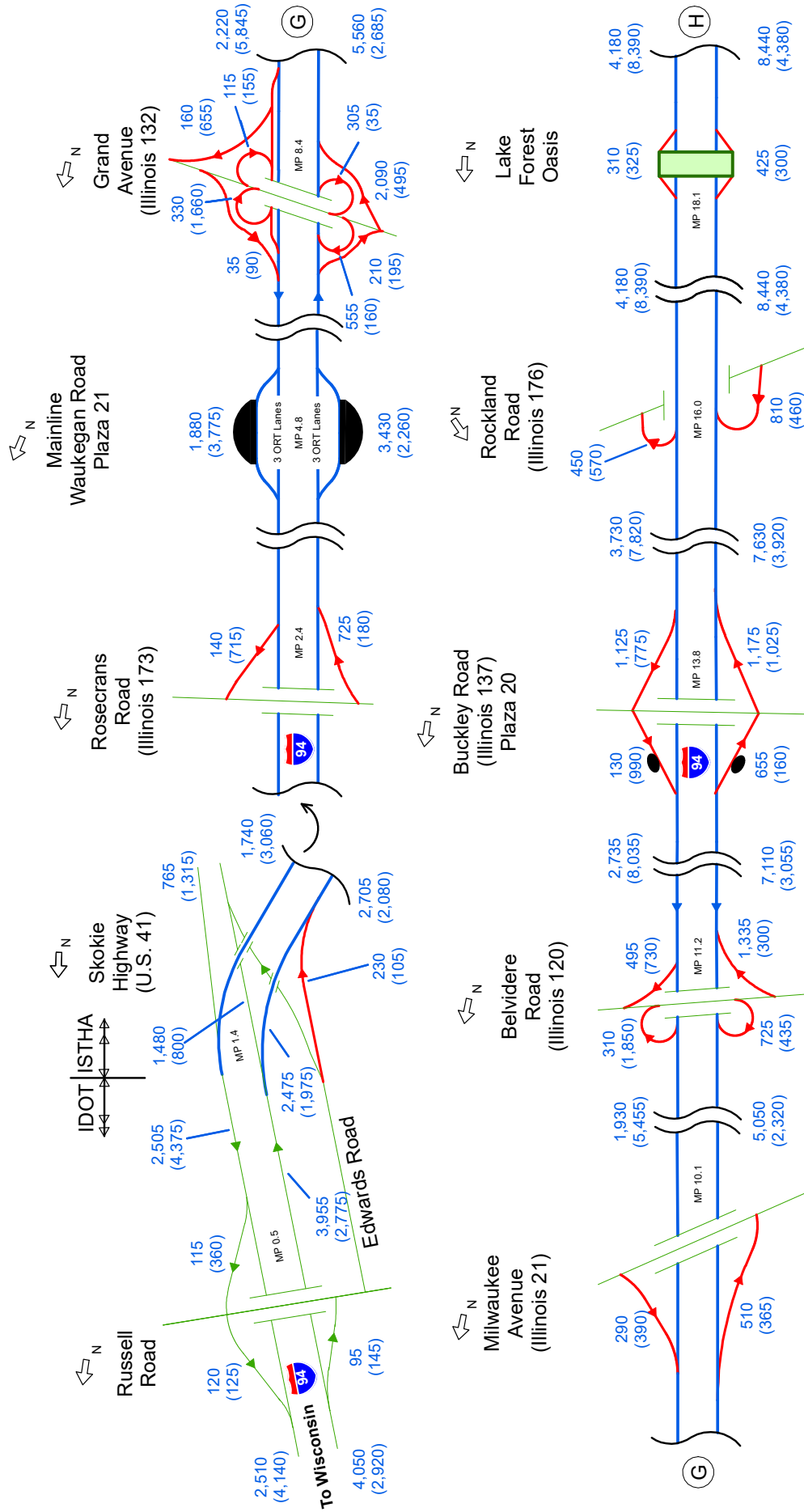

Note:
 The 2018 AM & PM peak-hour volumes are defined as the 85th Percentile volumes occurring in the 6:00 to 8:00 AM and the 4:00 to 6:00 PM periods respectively. Peak-hour volumes are calculated from Monday through Thursday hourly traffic volume data only, and exclude holidays.

**** = A.M. Peak
 (*, ***) = P.M. Peak





2018 A.M. & P.M. Peak Hour Traffic

On Tri-State Tollway, from Town Line Road (Illinois 60) to Golf Road (Illinois 58) and Edens Spur

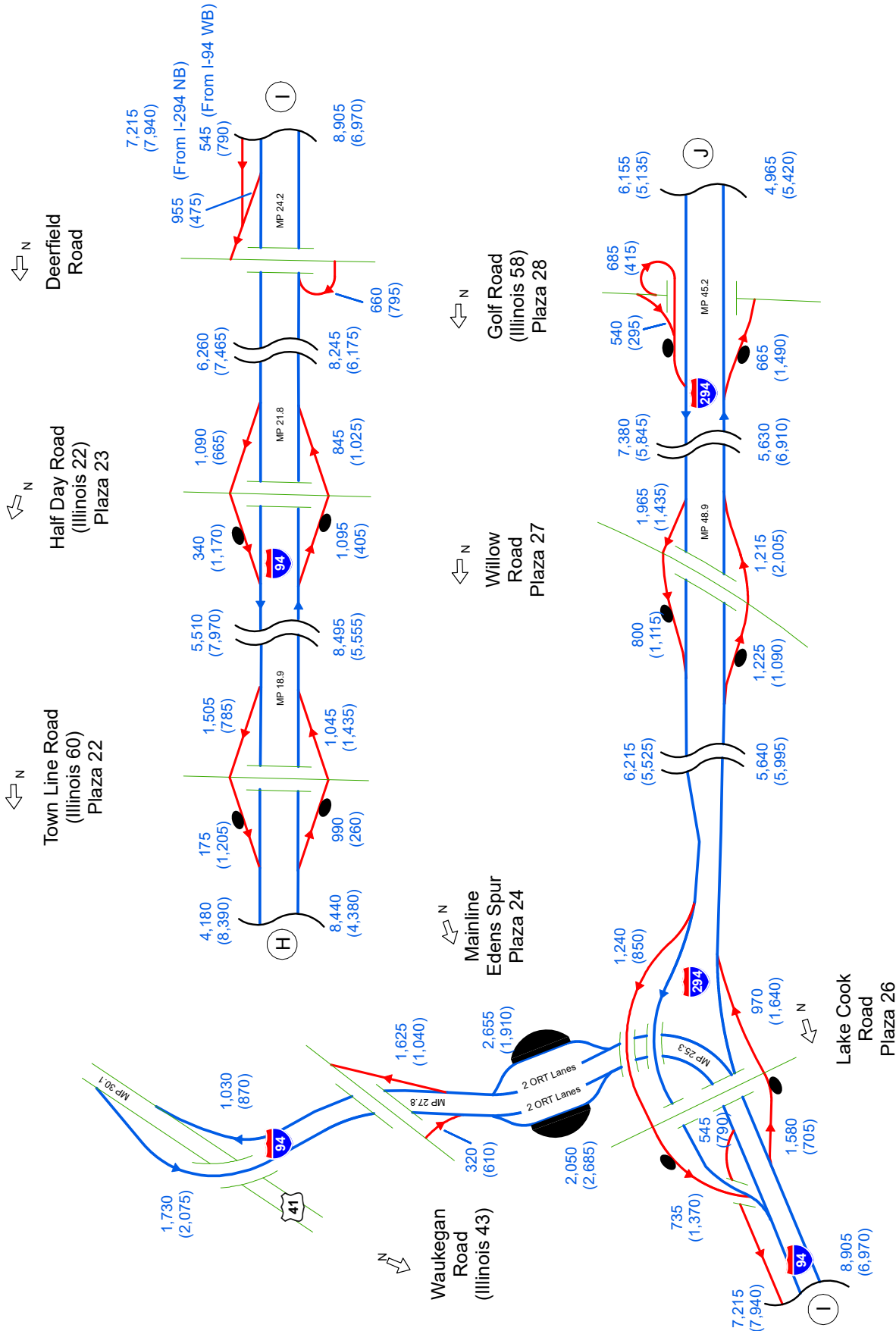

Note:
 The 2018 AM & PM peak-hour volumes are defined as the 85th Percentile volumes occurring in the 6:00 to 8:00 AM and the 4:00 to 6:00 PM periods respectively. Peak-hour volumes are calculated from Monday through Thursday hourly traffic volume data only, and exclude holidays.

**** = A.M. Peak
 (*, ***) = P.M. Peak





2018 A.M. & P.M. Peak Hour Traffic

On Tri-State Tollway, from Dempster Street to O'Hare Oasis

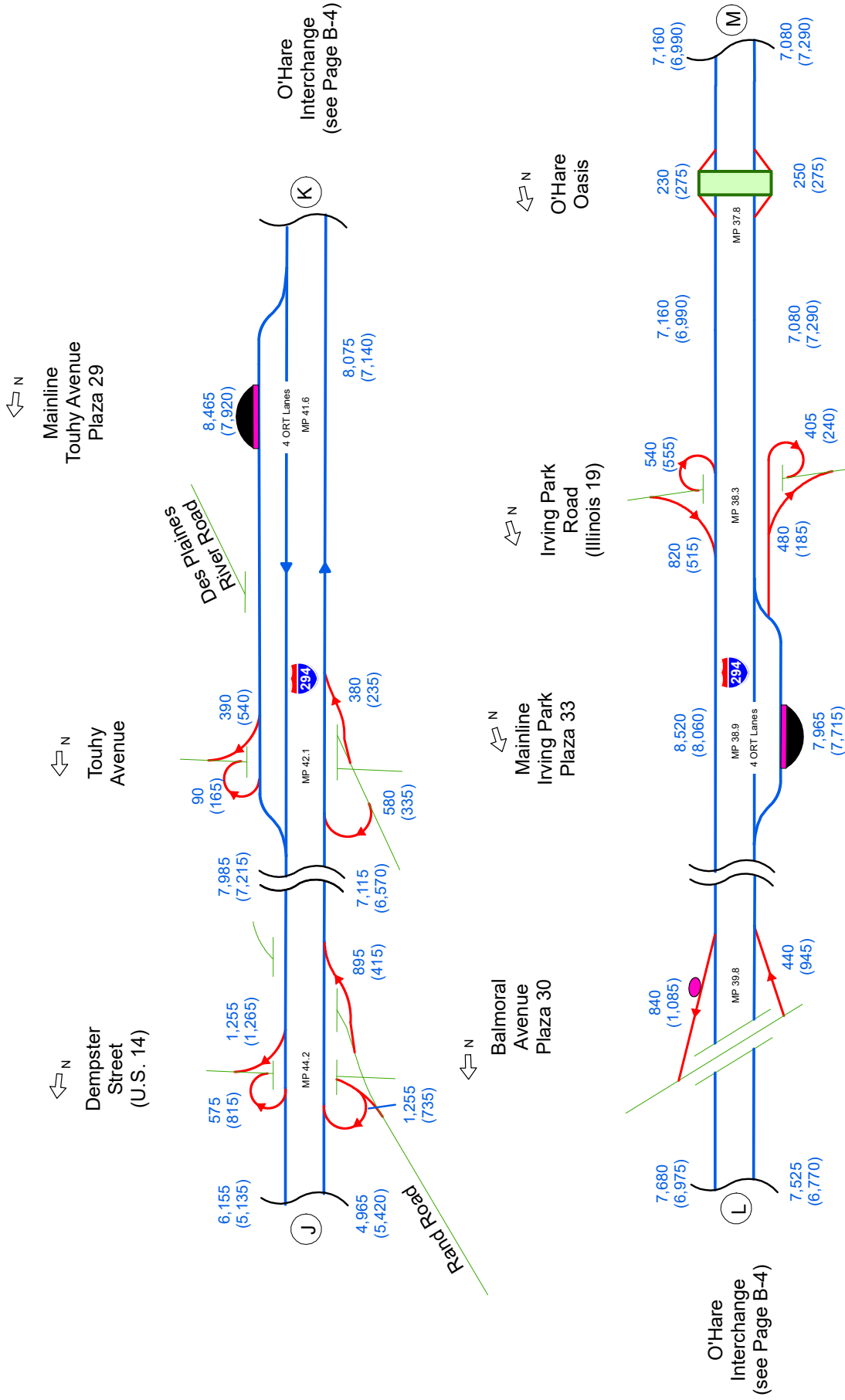

Note:
 The 2018 AM & PM peak-hour volumes are defined as the 85th Percentile volumes occurring in the 6:00 to 8:00 AM and the 4:00 to 6:00 PM periods respectively. Peak-hour volumes are calculated from Monday through Thursday hourly traffic volume data only, and exclude holidays.

*** = A.M. Peak
 (*, ***) = P.M. Peak





2018 A.M. & P.M. Peak Hour Traffic

On Tri-State Tollway, from North Avenue / Lake Street to Reagan Memorial Tollway (I-88)

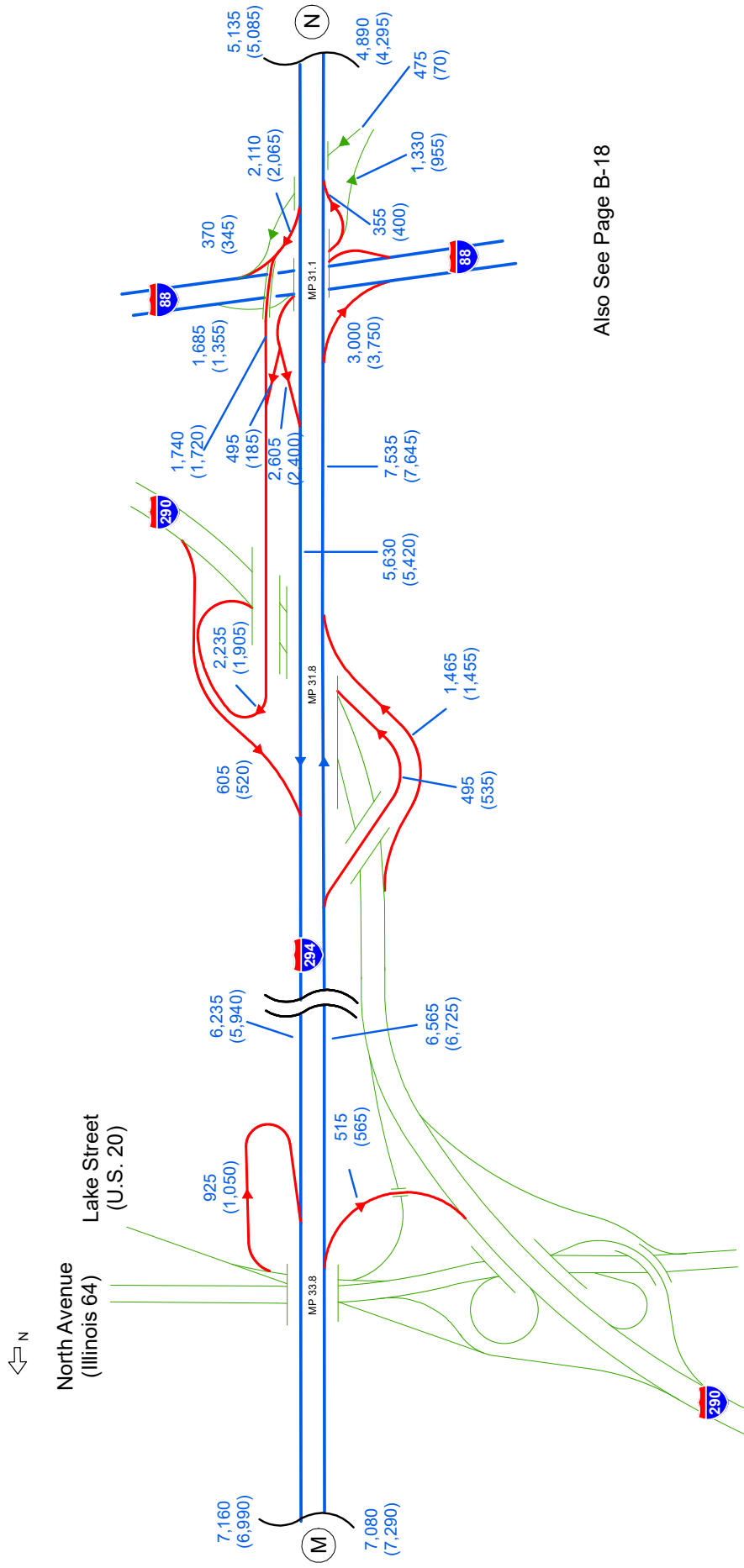

Also See Page B-18

Note:
 The 2018 AM & PM peak-hour volumes are defined as the 85th Percentile volumes occurring in the 6:00 to 8:00 AM and the 4:00 to 6:00 PM periods respectively. Peak-hour volumes are calculated from Monday through Thursday hourly traffic volume data only, and exclude holidays.

**** = A.M. Peak
 (*, ***) = P.M. Peak





2018 A.M. & P.M. Peak Hour Traffic

On Tri-State Tollway, from Roosevelt Road to Hinsdale Oasis

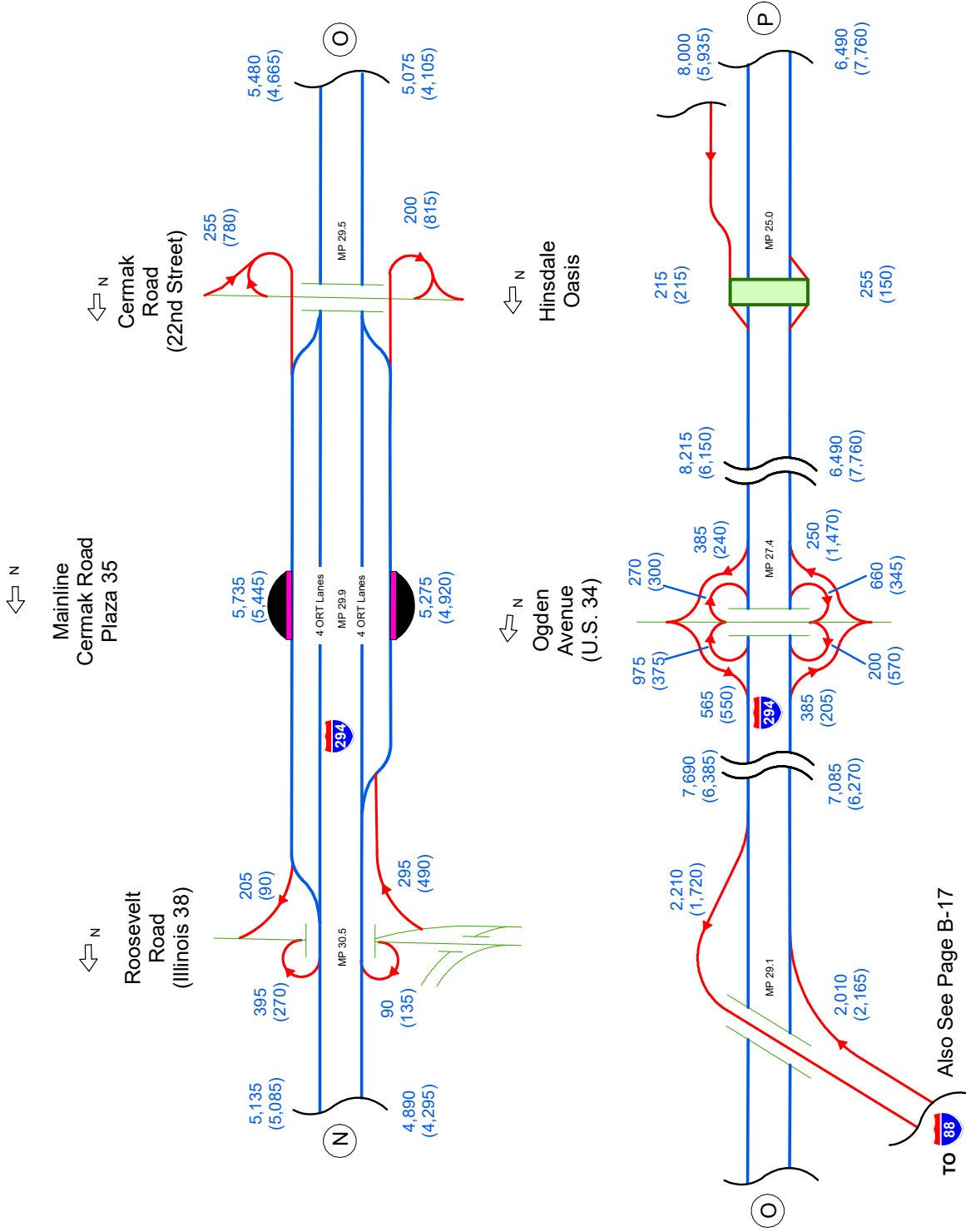

Also See Page B-17

Note:
The 2018 AM & PM peak-hour volumes are defined as the 85th Percentile volumes occurring in the 6:00 to 8:00 AM and the 4:00 to 6:00 PM periods respectively. Peak-hour volumes are calculated from Monday through Thursday hourly traffic volume data only, and exclude holidays.

**** = A.M. Peak
(*, ***) = P.M. Peak





2018 A.M. & P.M. Peak Hour Traffic

On Tri-State Tollway, from Joliet Road (Plaza 37) to Willow Springs Road (Plaza 34)

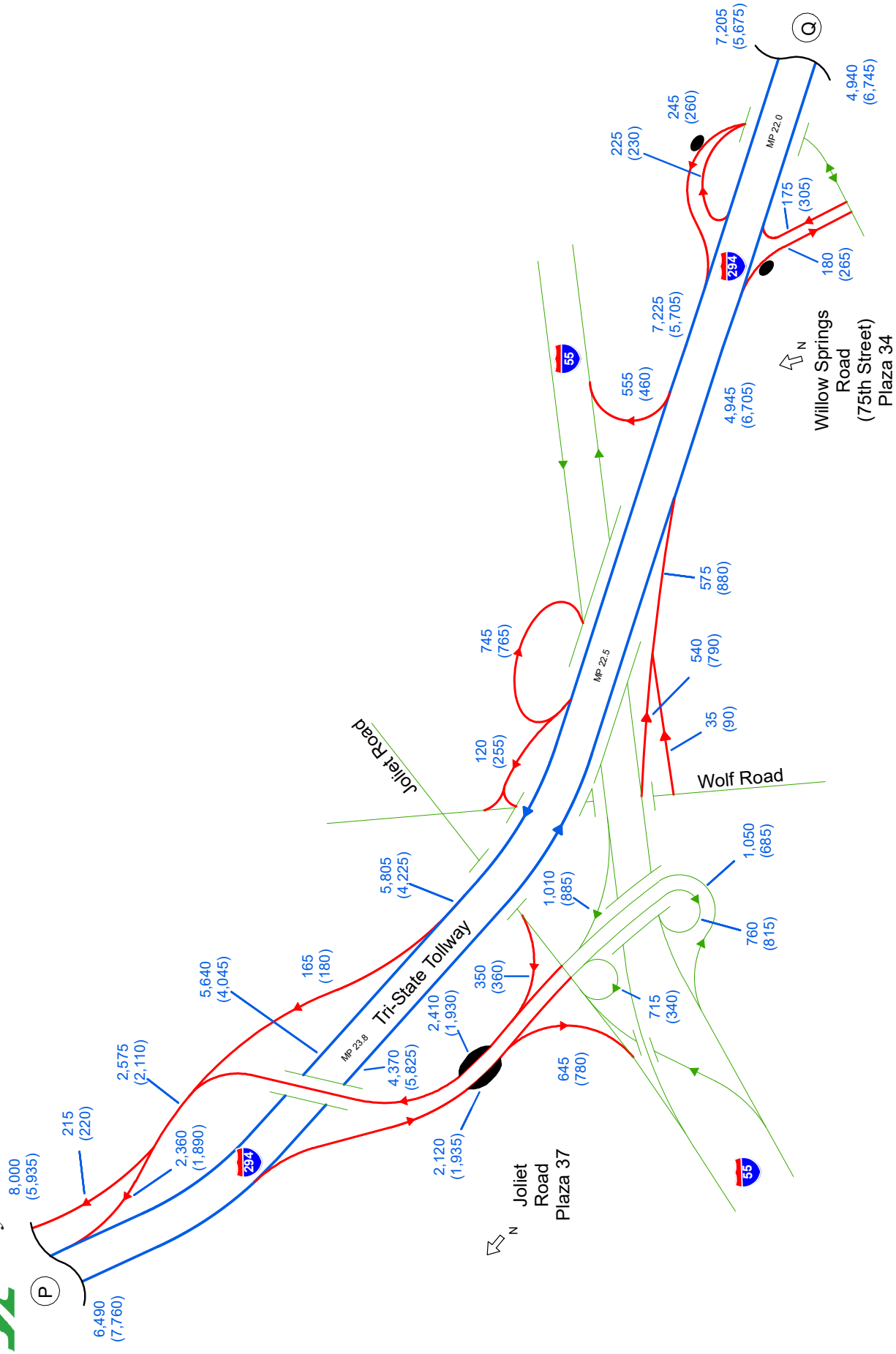

Note:
 The 2018 AM & PM peak-hour volumes are defined as the 85th Percentile volumes occurring in the 6:00 to 8:00 AM and the 4:00 to 6:00 PM periods respectively. Peak-hour volumes are calculated from Monday through Thursday hourly traffic volume data only, and exclude holidays.

**** = A.M. Peak
 (*, ***) = P.M. Peak





2018 A.M. & P.M. Peak Hour Traffic

On Tri-State Tollway, from Archer / Lagrange to 147th Street (Plaza 42) / I-57

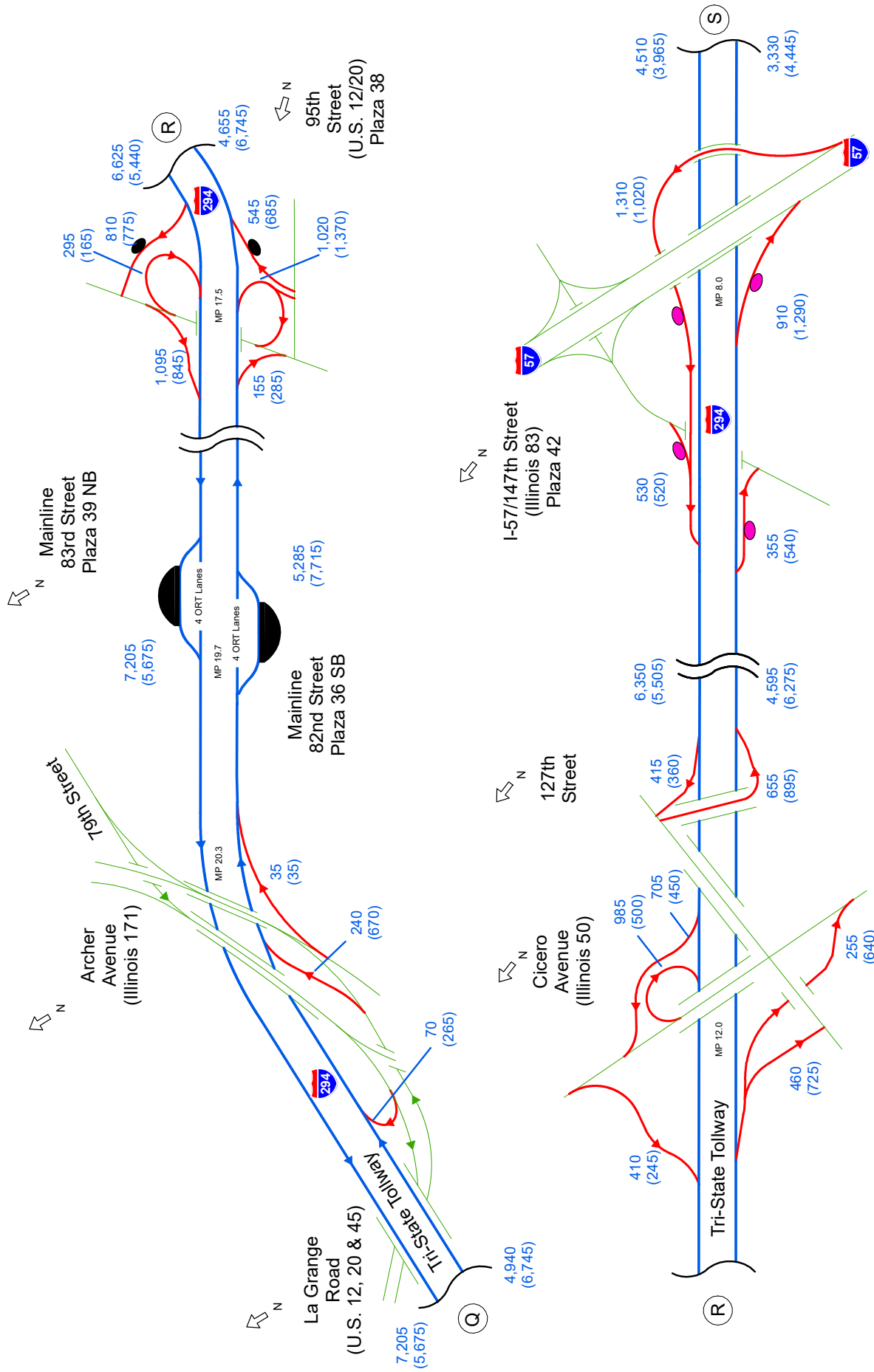

Note:
The 2018 AM & PM peak-hour volumes are defined as the 85th Percentile volumes occurring in the 6:00 to 8:00 AM and the 4:00 to 6:00 PM periods respectively. Peak-hour volumes are calculated from Monday through Thursday hourly traffic volume data only, and exclude holidays.



**** = A.M. Peak
(*, ***) = P.M. Peak



2018 A.M. & P.M. Peak Hour Traffic

On Tri-State Tollway, from 159th Street (Plaza 40) to Bishop Ford / Kingery Expressway

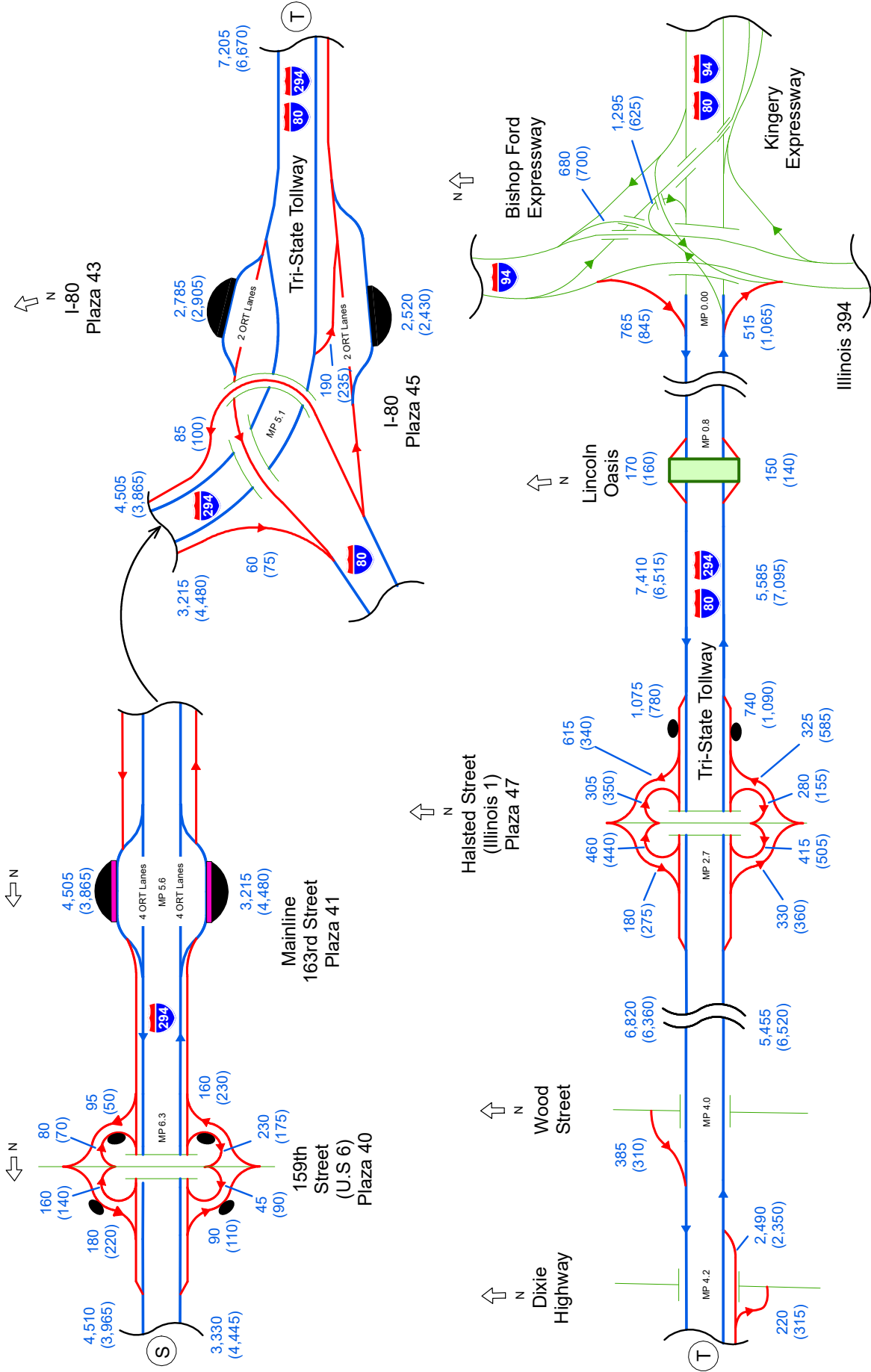

Note:
The 2018 AM & PM peak-hour volumes are defined as the 85th Percentile volumes occurring in the 6:00 to 8:00 AM and the 4:00 to 6:00 PM periods respectively. Peak-hour volumes are calculated from Monday through Thursday hourly traffic volume data only, and exclude holidays.

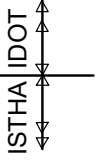

**** = A.M. Peak
(*, ***) = P.M. Peak





2018 A.M. & P.M. Peak Hour Traffic

On Reagan Memorial Tollway, from Illinois 26 to Orchard Road

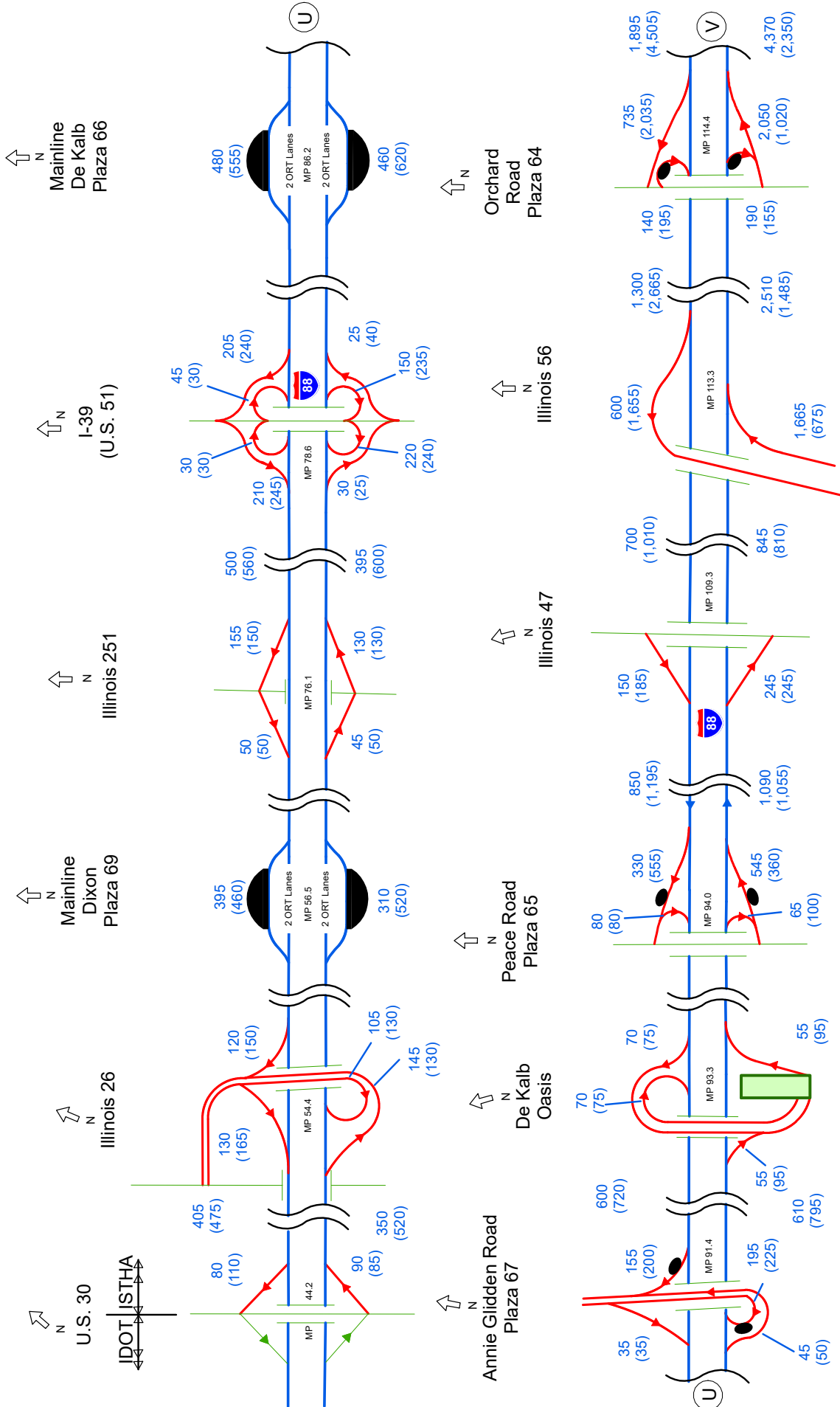

Note:
 The 2018 AM & PM peak-hour volumes are defined as the 85th Percentile volumes occurring in the 6:00 to 8:00 AM and the 4:00 to 6:00 PM periods respectively. Peak-hour volumes are calculated from Monday through Thursday hourly traffic volume data only, and exclude holidays.

* ** = A.M. Peak
 (*, **) = P.M. Peak





2018 A.M. & P.M. Peak Hour Traffic

On Reagan Memorial Tollway, from Illinois 31 to Illinois 53

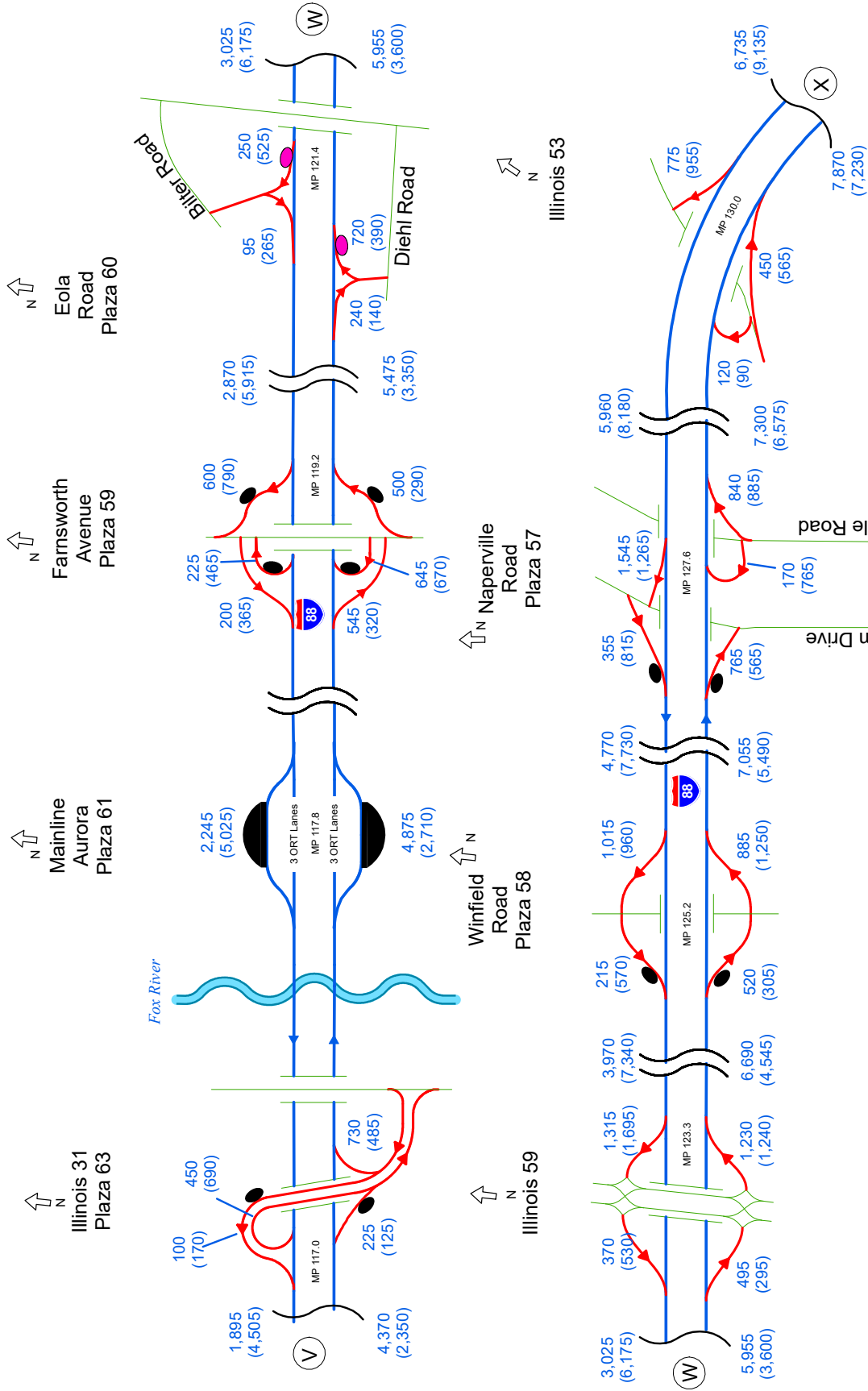

Note:
 The 2018 AM & PM peak-hour volumes are defined as the 85th Percentile volumes occurring in the 6:00 to 8:00 AM and the 4:00 to 6:00 PM periods respectively. Peak-hour volumes are calculated from Monday through Thursday hourly traffic volume data only, and exclude holidays.

*** = A.M. Peak
 (*, ***) = P.M. Peak





2018 A.M. & P.M. Peak Hour Traffic

On Reagan Memorial Tollway, Veterans Memorial Tollway West Interchange

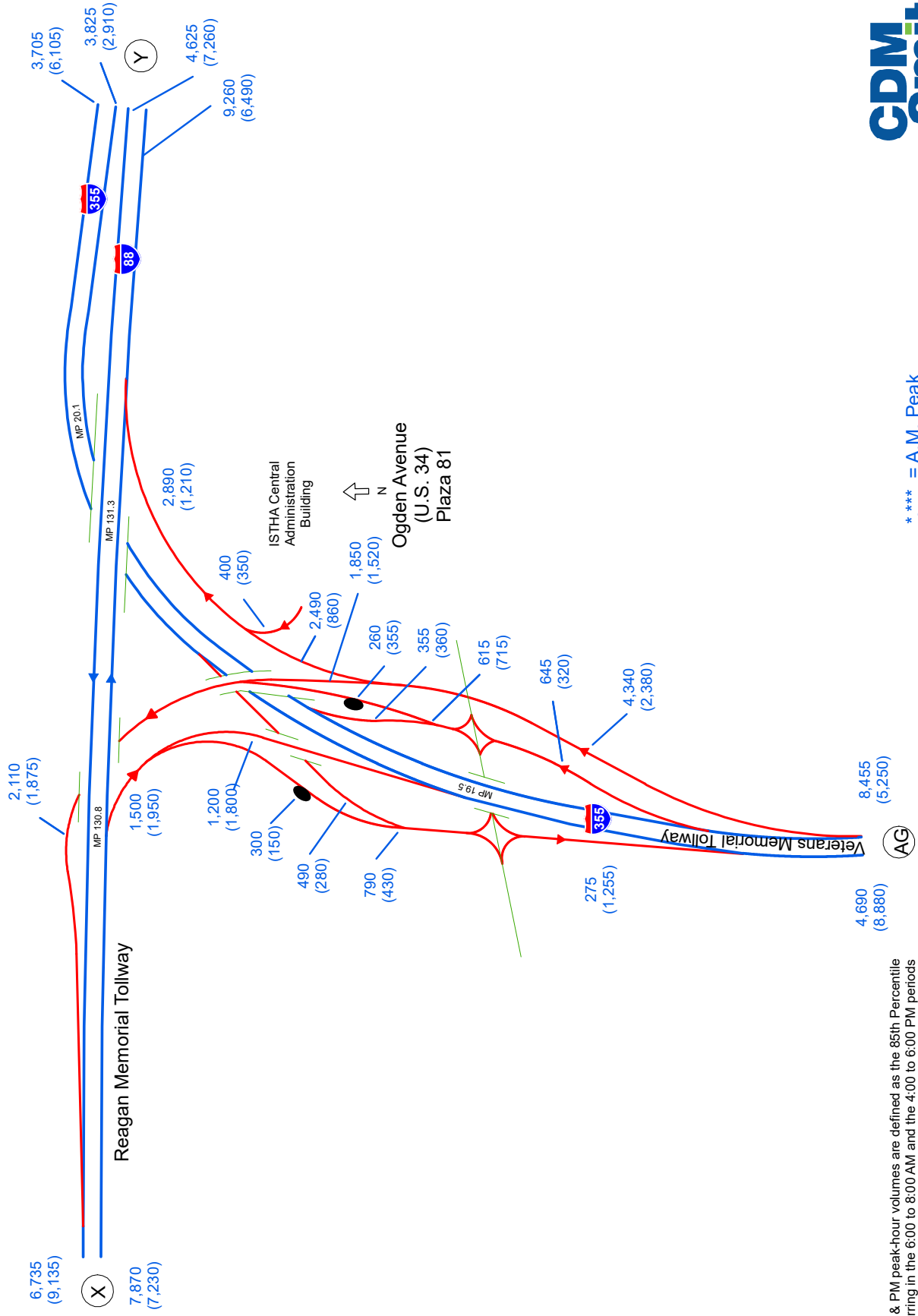

Note:
 The 2018 AM & PM peak-hour volumes are defined as the 85th Percentile volumes occurring in the 6:00 to 8:00 AM and the 4:00 to 6:00 PM periods respectively. Peak-hour volumes are calculated from Monday through Thursday hourly traffic volume data only, and exclude holidays.

**** = A.M. Peak
 (*, ***) = P.M. Peak





2018 A.M. & P.M. Peak Hour Traffic

On Reagan Memorial Tollway, Veterans Memorial Tollway East Interchange

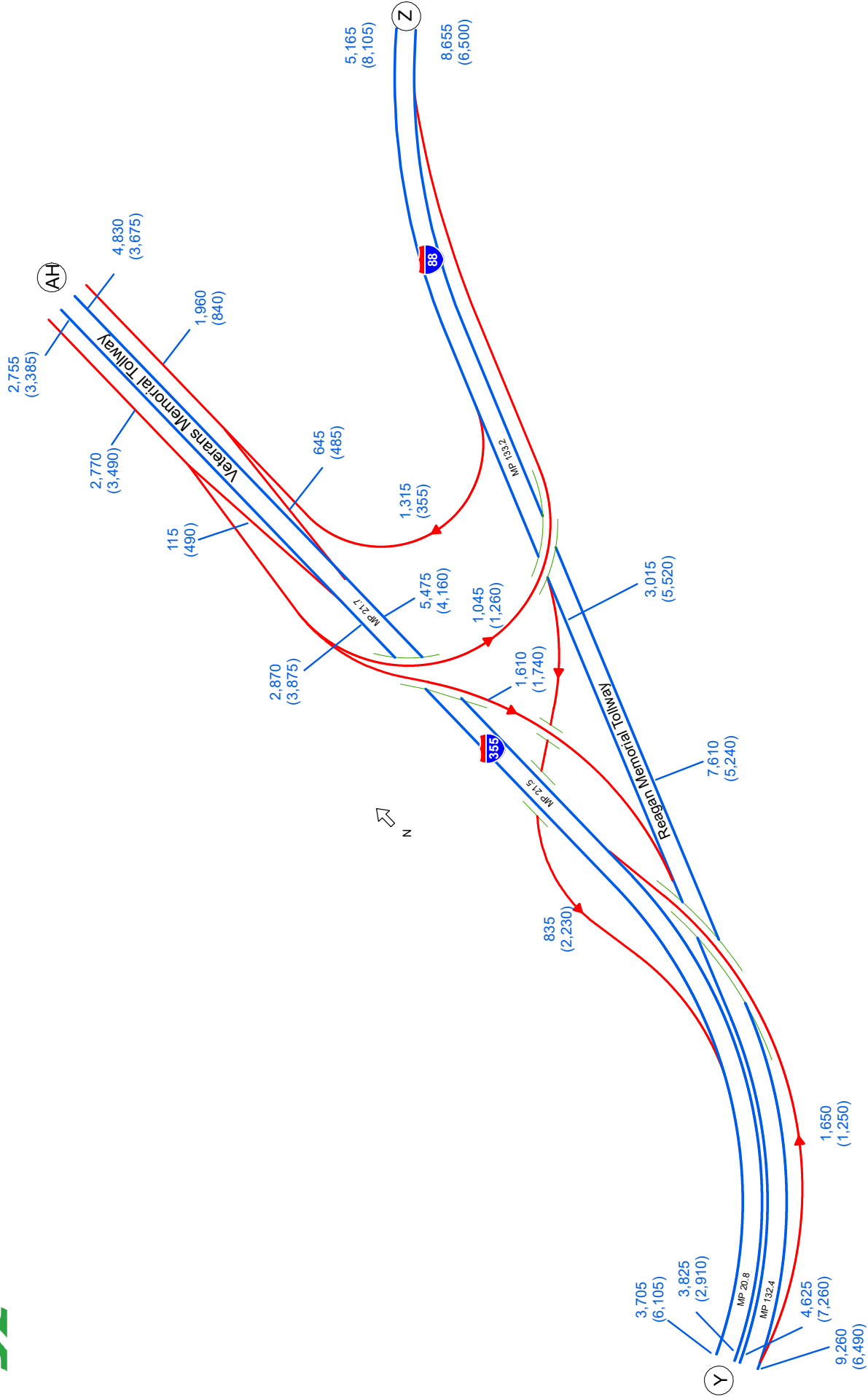

Note:
 The 2018 AM & PM peak-hour volumes are defined as the 85th Percentile volumes occurring in the 6:00 to 8:00 AM and the 4:00 to 6:00 PM periods respectively. Peak-hour volumes are calculated from Monday through Thursday hourly traffic volume data only, and exclude holidays.

**** = A.M. Peak
 (*, ***) = P.M. Peak





2018 A.M. & P.M. Peak Hour Traffic

On Reagan Memorial Tollway, from Highland Avenue to Harger Road

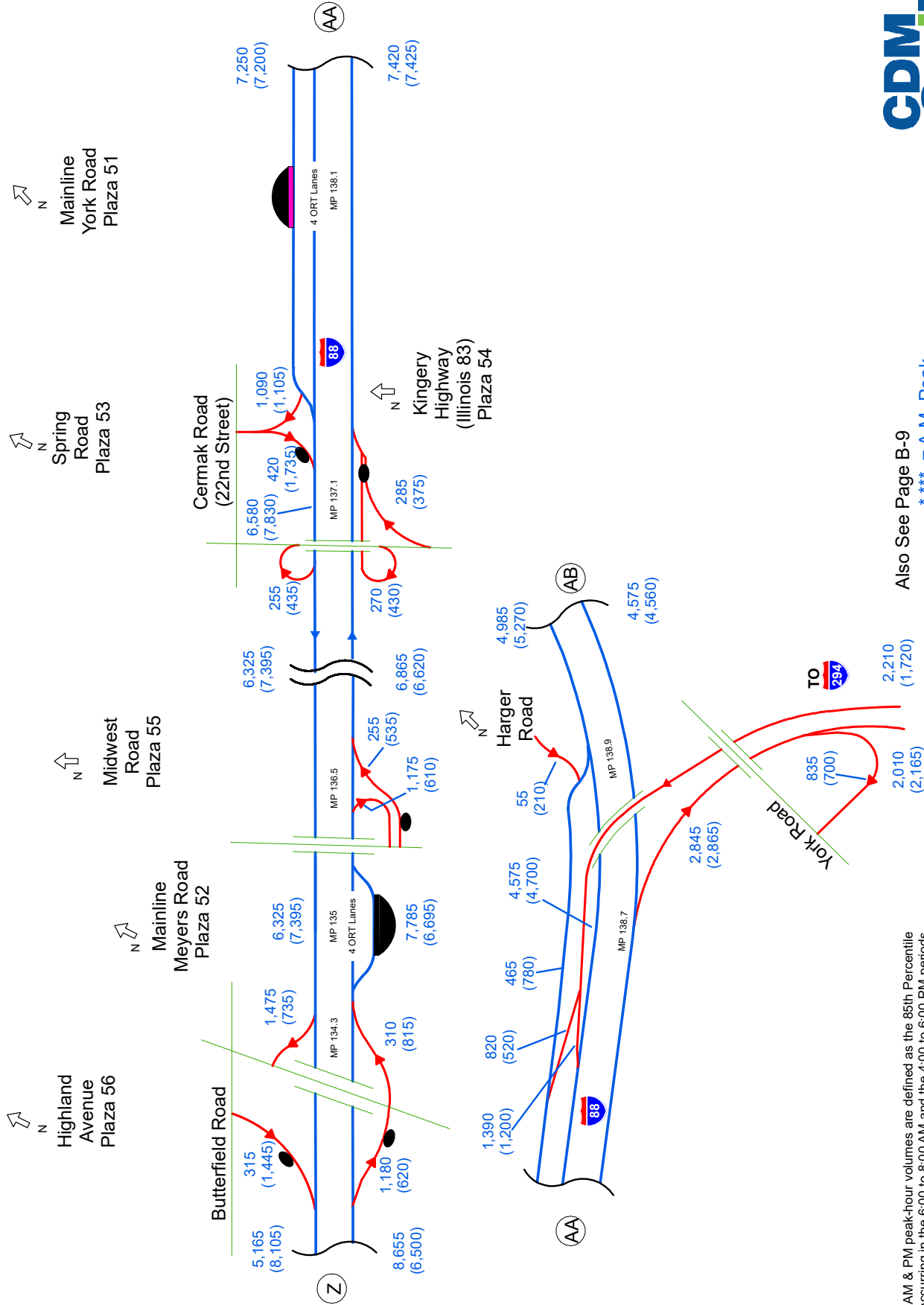

Note:
 The 2018 AM & PM peak-hour volumes are defined as the 85th Percentile volumes occurring in the 6:00 to 8:00 AM and the 4:00 to 6:00 PM periods respectively. Peak-hour volumes are calculated from Monday through Thursday hourly traffic volume data only, and exclude holidays.

Also See Page B-9
 * ** = A.M. Peak
 (*, **) = P.M. Peak

B-17





2018 A.M. & P.M. Peak Hour Traffic

On Reagan Memorial Tollway, from Roosevelt Road to Eisenhower Expressway (I-290)

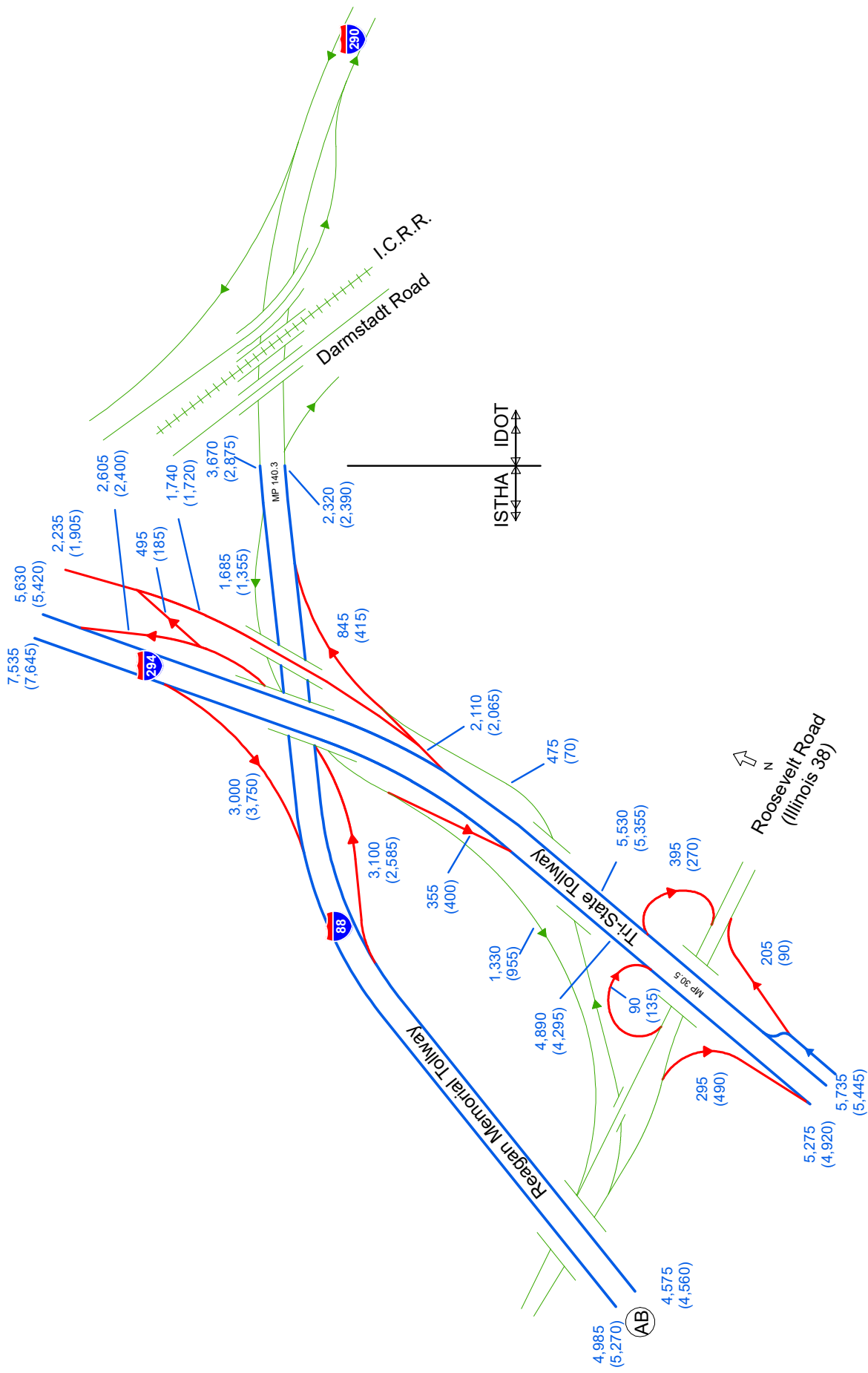

Note:
 The 2018 AM & PM peak-hour volumes are defined as the 85th Percentile volumes occurring in the 6:00 to 8:00 AM and the 4:00 to 6:00 PM periods respectively. Peak-hour volumes are calculated from Monday through Thursday hourly traffic volume data only, and exclude holidays.

**** = A.M. Peak
 (*, ***) = P.M. Peak





2018 A.M. & P.M. Peak Hour Traffic

On Veterans Memorial Tollway, from Interstate 80 to 127th Street

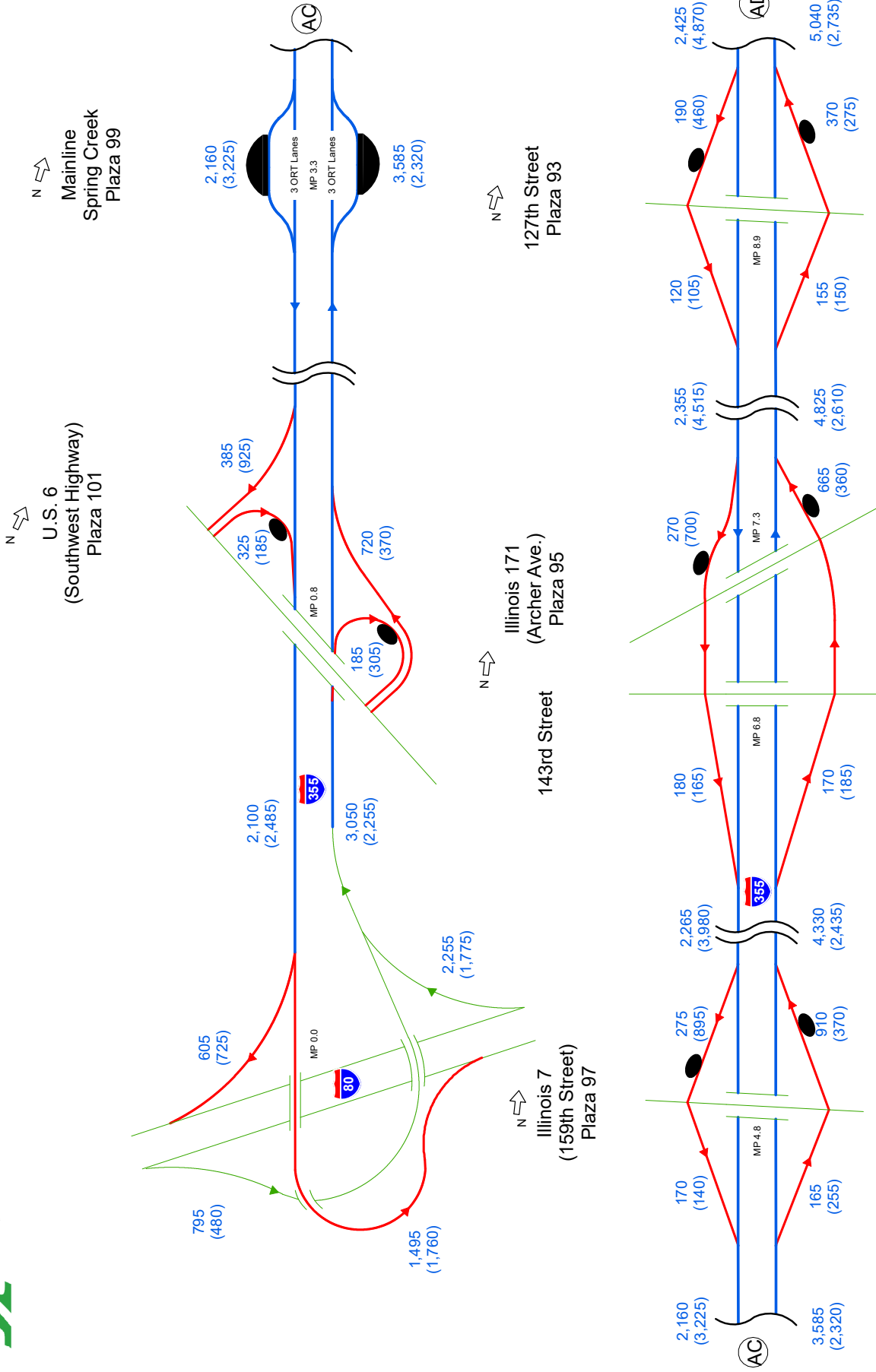

Note:
 The 2018 AM & PM peak-hour volumes are defined as the 85th Percentile volumes occurring in the 6:00 to 8:00 AM and the 4:00 to 6:00 PM periods respectively. Peak-hour volumes are calculated from Monday through Thursday hourly traffic volume data only, and exclude holidays.

**** = A.M. Peak
 (*, ***) = P.M. Peak





2018 A.M. & P.M. Peak Hour Traffic

On Veterans Memorial Tollway, At Interstate 55

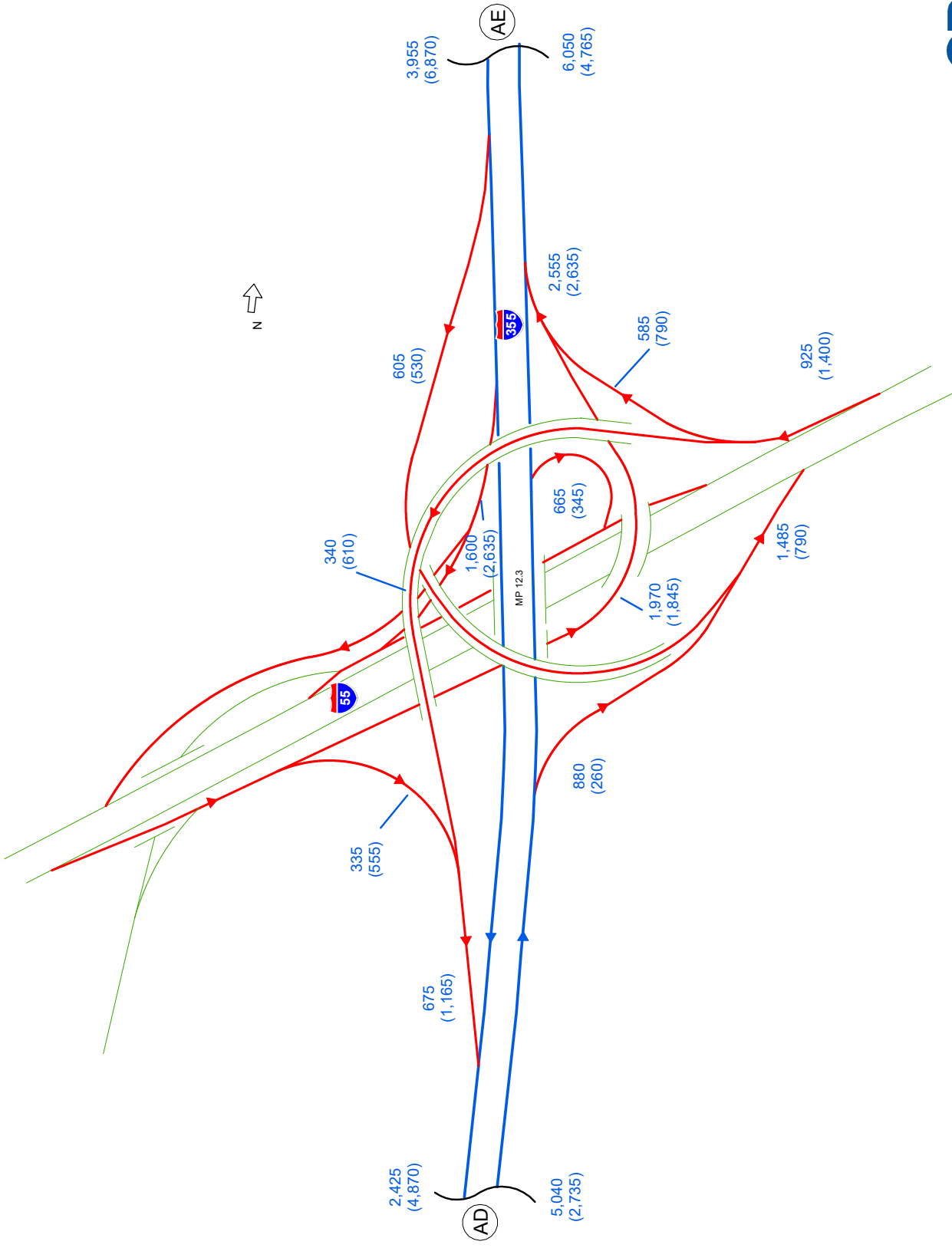

Note:
The 2018 AM & PM peak-hour volumes are defined as the 85th Percentile volumes occurring in the 6:00 to 8:00 AM and the 4:00 to 6:00 PM periods respectively. Peak-hour volumes are calculated from Monday through Thursday hourly traffic volume data only, and exclude holidays.

**** = A.M. Peak
(* , **) = P.M. Peak

B-20





2018 A.M. & P.M. Peak Hour Traffic

On Veterans Memorial Tollway, from Boughton Road to Maple Avenue

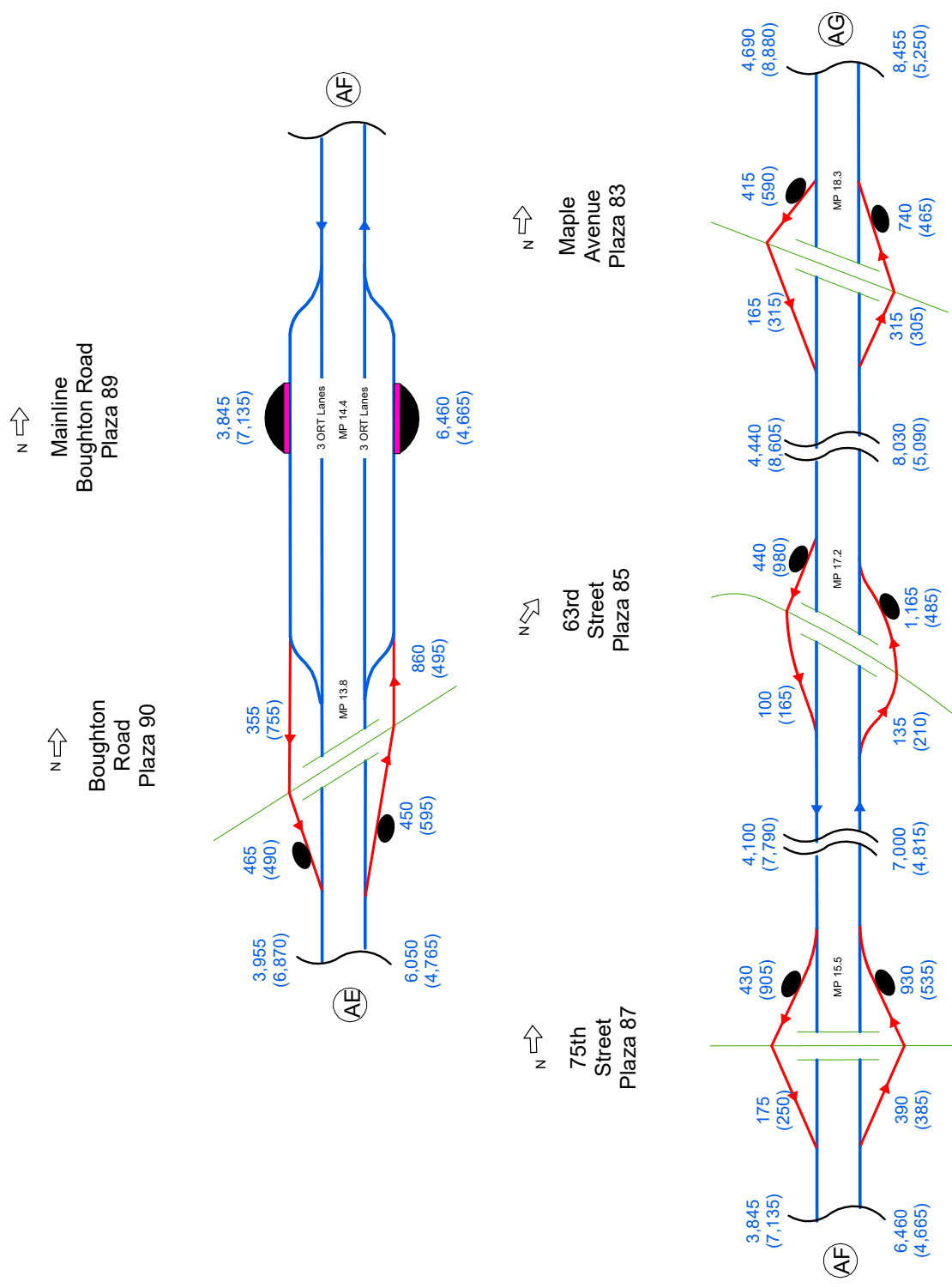

Note:
 The 2018 AM & PM peak-hour volumes are defined as the 85th Percentile volumes occurring in the 6:00 to 8:00 AM and the 4:00 to 6:00 PM periods respectively. Peak-hour volumes are calculated from Monday through Thursday hourly traffic volume data only, and exclude holidays.

*** = A.M. Peak
 (*, **) = P.M. Peak





2018 A.M. & P.M. Peak Hour Traffic

On Veterans Memorial Tollway, from Ogden Avenue / West Interchange to Army Trail Road

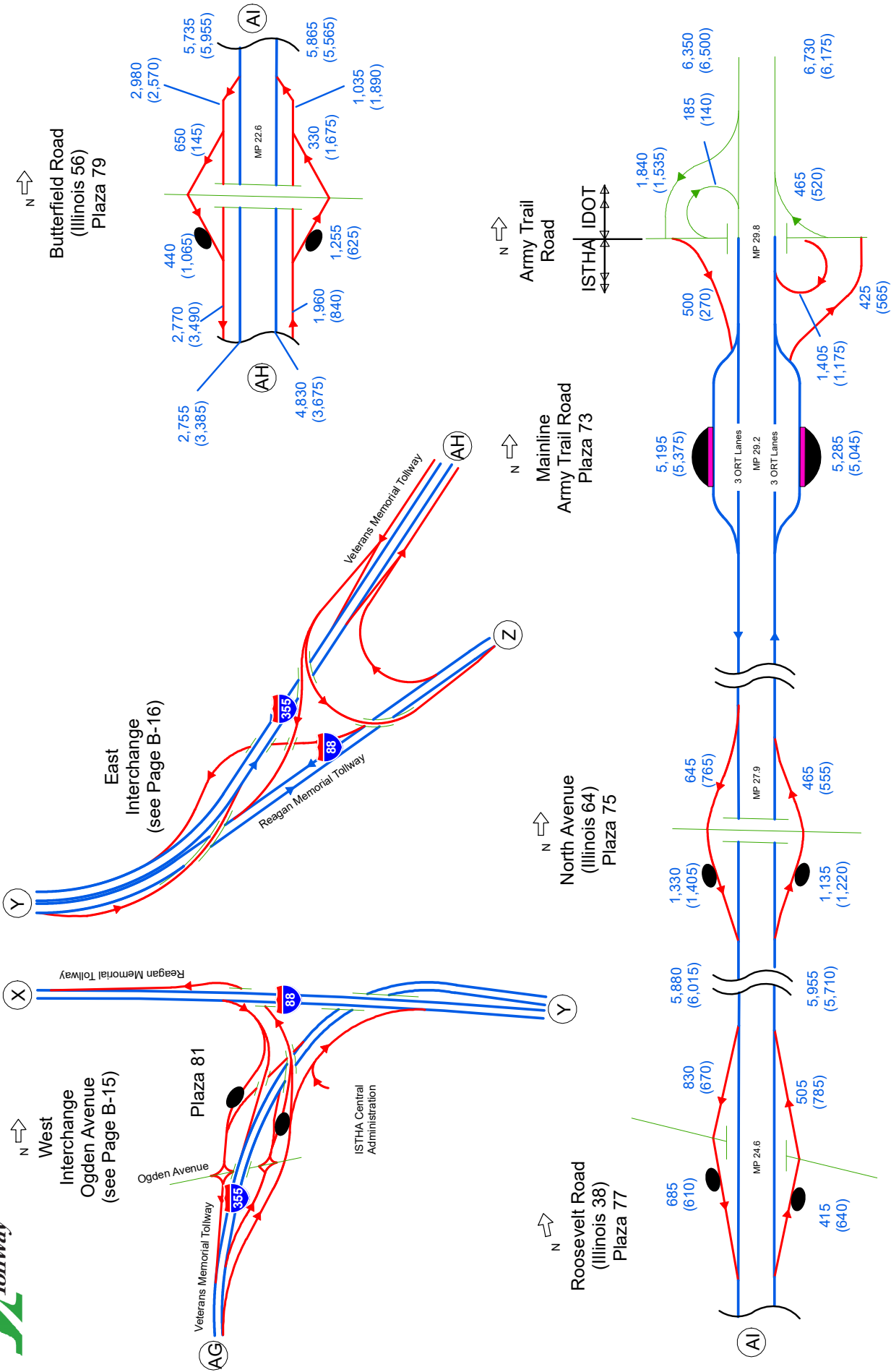

Note: The 2018 AM & PM peak-hour volumes are defined as the 85th Percentile volumes occurring in the 6:00 to 8:00 AM and the 4:00 to 6:00 PM periods respectively. Peak-hour volumes are calculated from Monday through Thursday hourly traffic volume data only, and exclude holidays.

* ** = A.M. Peak
 (*, **) = P.M. Peak





2018 A.M. & P.M. Peak Hour Traffic

On IL 390, from Lake Street to Plum Grove Road (Plaza 326)

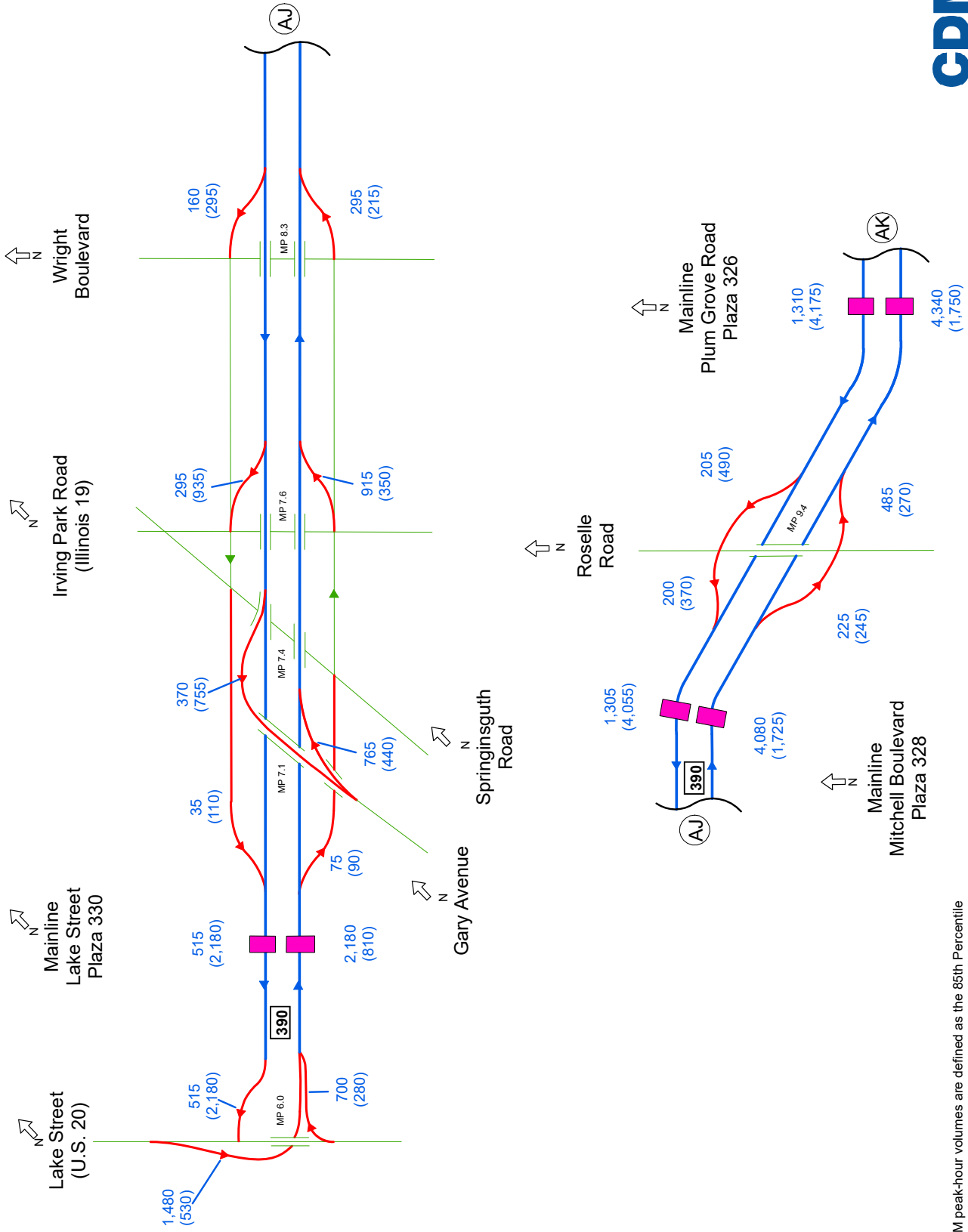

Note:
 The 2018 AM & PM peak-hour volumes are defined as the 85th Percentile volumes occurring in the 6:00 to 8:00 AM and the 4:00 to 6:00 PM periods respectively. Peak-hour volumes are calculated from Monday through Thursday hourly traffic volume data only, and exclude holidays.

**** = A.M. Peak
 (*, ***) = P.M. Peak





2018 A.M. & P.M. Peak Hour Traffic

On IL 390, from Plum Grove Road (Plaza 326) to Busse Road (Illinois 83)

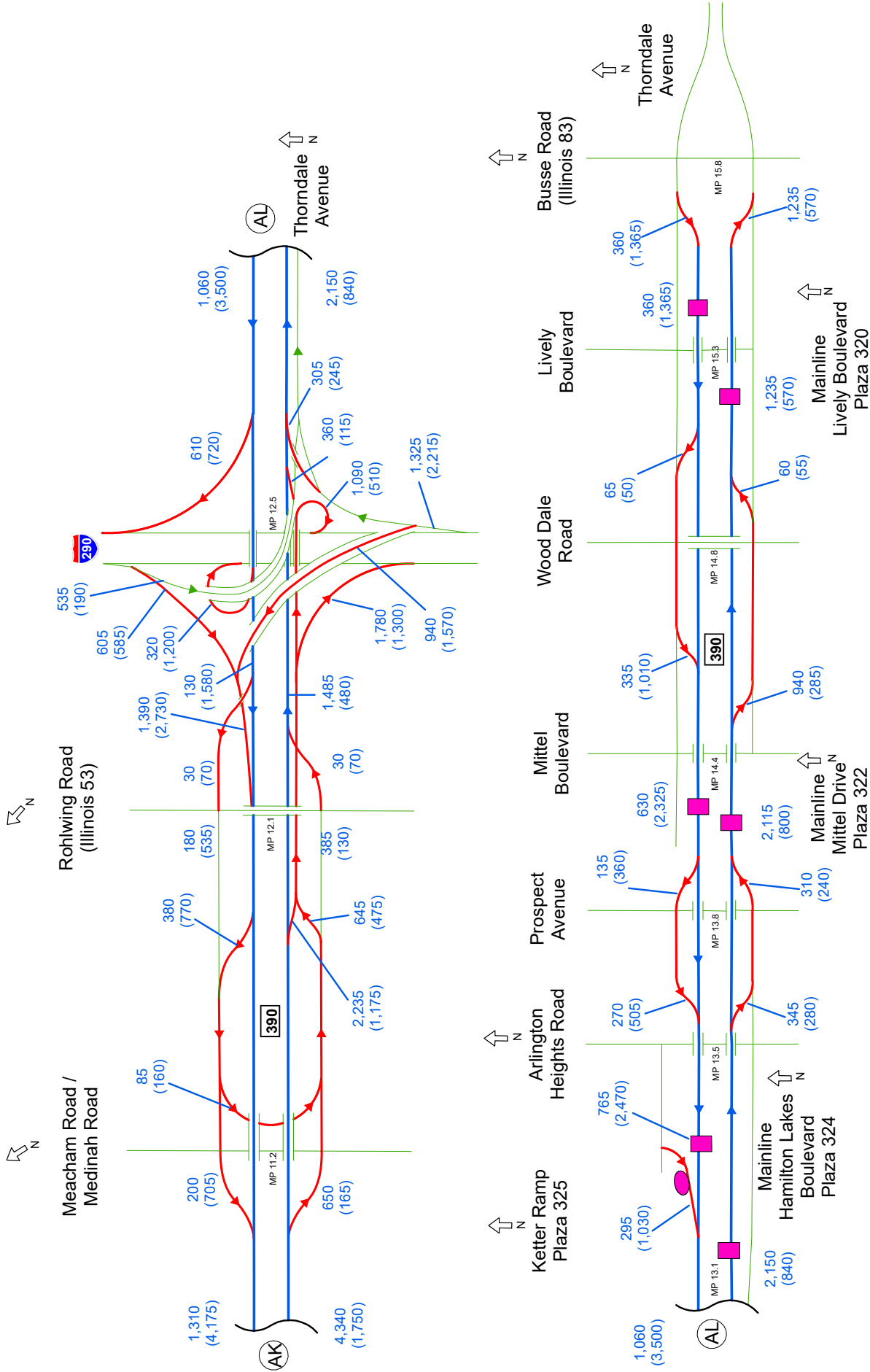

Note:
 The 2018 AM & PM peak-hour volumes are defined as the 85th Percentile volumes occurring in the 6:00 to 8:00 AM and the 4:00 to 6:00 PM periods respectively. Peak-hour volumes are calculated from Monday through Thursday hourly traffic volume data only, and exclude holidays.

**** = A.M. Peak
 (*, ***) = P.M. Peak





Appendix C

2018 Lane Configuration Schematics

2018 CONSTRUCTION PROJECTS

Page #	Facility	Description	Milepost		Construction Schedule	
			Start	End	Start	End
Illinois Tollway						
C-3	I-90	New Ramp Construction Roselle Road/Central Ave WB I-90 Entrance Ramp	65.5		2017	2018
C-3	I-90	I-490 Interchange Construction	74.4		09/2018	2020
C-5	I-94	Bridge Reconstruction Bradley Road Bridge	17.3		2018	Summer 2019
C-5, C-6	I-94	Roadway and Ramp Repairs Half Day Road to Wisconsin State Line	1.4	21.8	Winter 2018	Spring 2019
C-6	I-94	Roadway Reconstruction Pfungsten Road to Edens Expressway	26.7	30.1	Summer 2018	Summer 2020
C-6, C-7	I-294	Roadway and Ramp Repairs Balmoral Avenue to Lake Cook Road	39.8	52.7	Spring 2018	Spring 2019
C-7	I-294	Roadway Reconstruction O'Hare Oasis to Balmoral Avenue	37.6	39.8	Summer 2018	Summer 2020
C-9	I-294	Plaza 35 Inside Shoulder Reconstruction	29.9		Spring 2018	Fall 2018
C-9, N/A	I-294	Overhead Bridges Repairs (Multiple) Between Cermak Road and 5th Avenue	22.2	29.5	2018	2018
C-10, C-11	I-294	Bridge Repair Mile Long Bridge	20.4	22.0	2017	2021 (Major Work 2018)
C-11	I-294	Plaza 36/39 Inside Shoulder Reconstruction and ORT Replacement	19.7		Spring 2018	Summer 2019
C-12	I-294	Interchange Reconstruction 159th Street	6.4		04/2018	Spring 2019
C-13	I-88	Roadway Resurfacing, Ramp Repairs, and Bridge Repairs IL 251 to IL 56	76.1	113.8	Spring 2018	Summer 2019
C-13	I-88	Outside Ramp Reconstruction Orchard Road	114.4		Summer 2018	Spring 2019
C-14, C-15	I-88	Roadway Repairs Washington Street To I-88 / I-355 Connector	126.4	130.8	2018	2018
C-17, C-18	I-88	Roadway Reconstruction York Road to I-290	138.9	140.7	12/2017	2019
C-19, C-20	I-355	Roadway Repairs South Extension (I-55 to I-80)	0.0	12.3	Spring 2018	Summer 2019
C-20 to C-22	I-355	Resurfacing and Bridge Repairs I-55 to Army Trail Road	12.3	29.8	Spring 2018	Summer 2019
C-22	I-355	Roadway Widening Between Butterfield Road (IL 56) and Roosevelt Road (IL 38)	22.7	24.7	Spring 2018	Summer 2019
N/A	IL 390	Roadway Construction IL 83 to York Road			2017	2021

2018 CONSTRUCTION PROJECTS

Page #	Facility	Description	Milepost		Construction Schedule	
			Start	End	Start	End
IDOT System						
C-1	US 20 BUS	Add Lane Bell School Road to I-90 Exit Ramp (WB)			Fall 2018	Winter 2019
C-4	I-90	Add Lane and Cumberland Flyover I-190 to Harlem Avenue			10/2016	10/2018
C-5	IL 132	Rehabilitation I-94 to IL 131			08/2018	07/2019
N/A	I-90/94	Jane Byrne Interchange Project I-90/94 at I-290			2015	2025
N/A	I-55	Interchange Reconstruction Weber Road			10/2018	2019
N/A	I-290	Bridge Replacement Salt Creek			07/2018	2019
N/A	US 20	Rehabilitation Shales Parkway to North Avenue (Hanover Park)			08/2018	06/2019



2018 Lane Configuration

On Jane Addams Memorial Tollway, from Rockton Road to Marengo (Plaza 7)

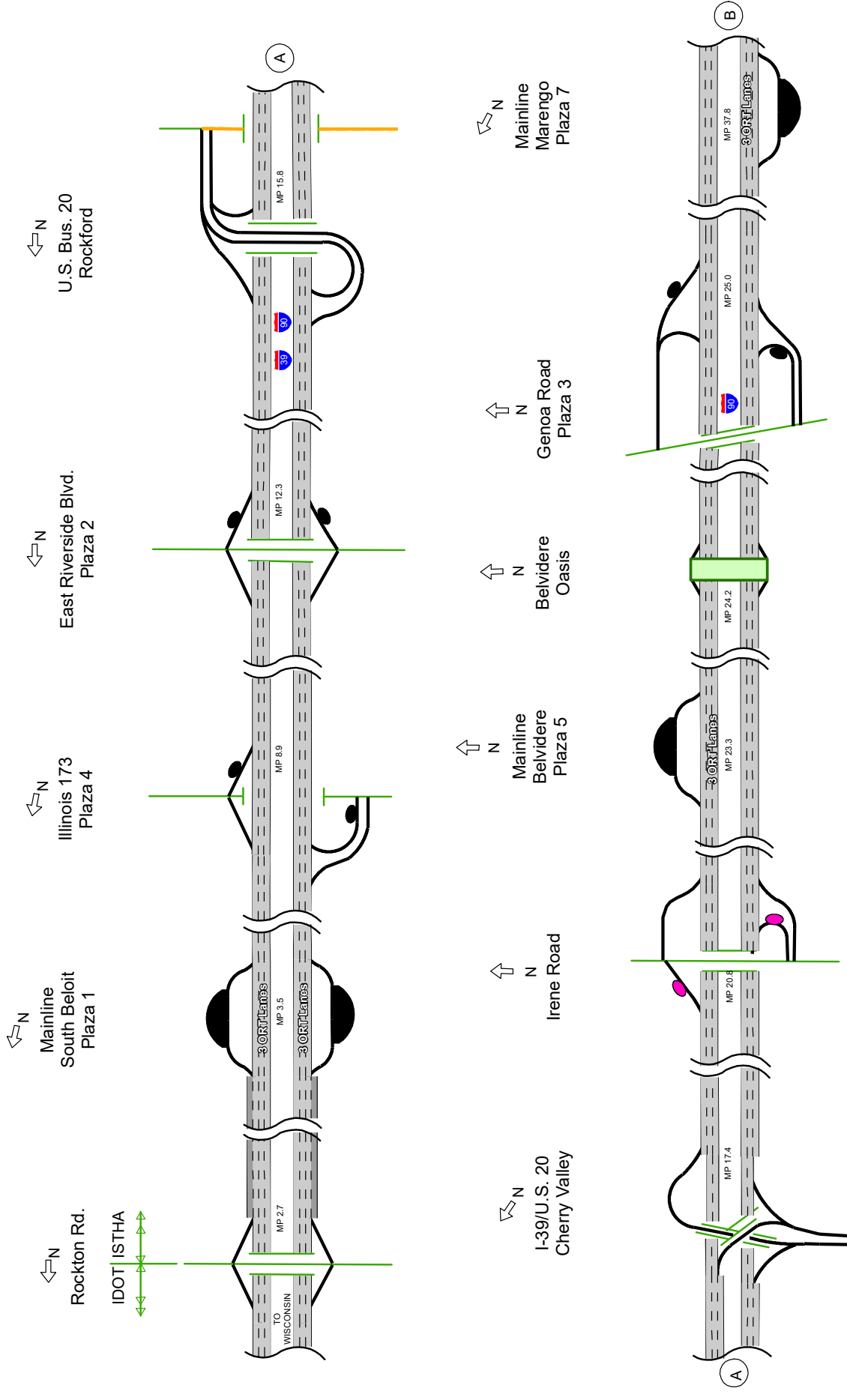

- Rehabilitation Project
- Construction Project





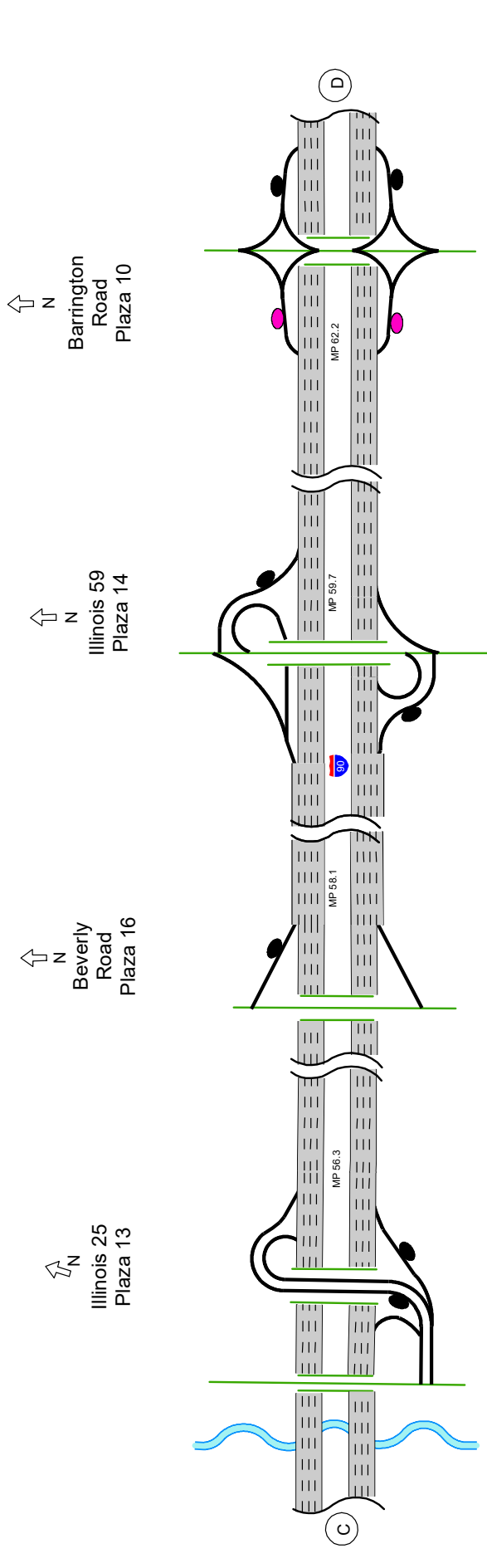
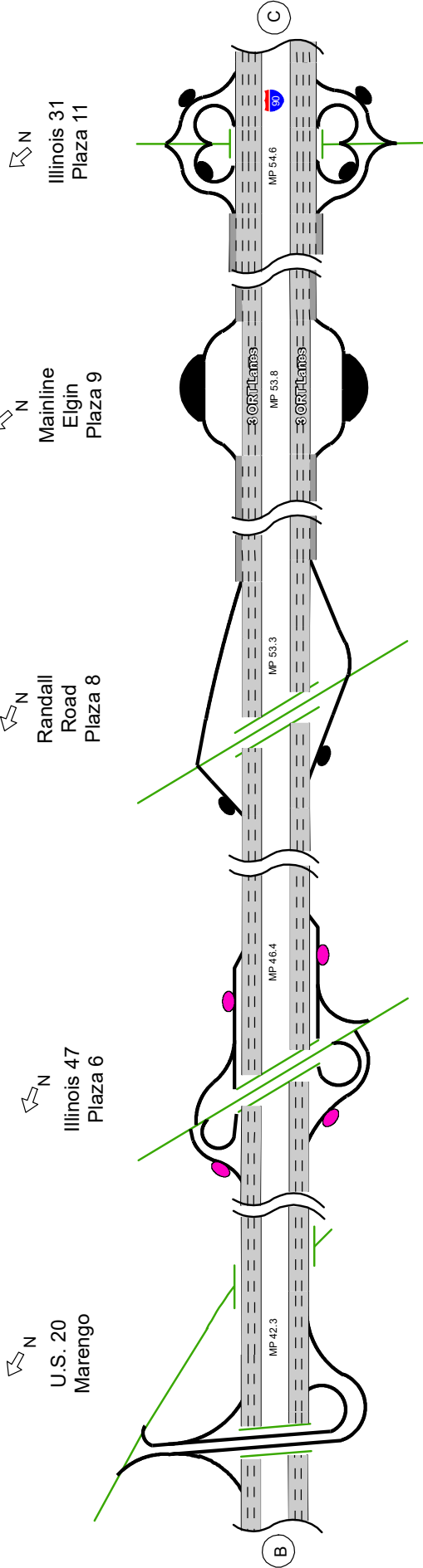

2018 Lane Configuration

On Jane Addams Memorial Tollway, from U.S. 20, Marengo to Barrington Road



Fox River

-  Rehabilitation Project
-  Construction Project





2018 Lane Configuration

On Jane Addams Memorial Tollway, from Roselle Road to Devon Avenue

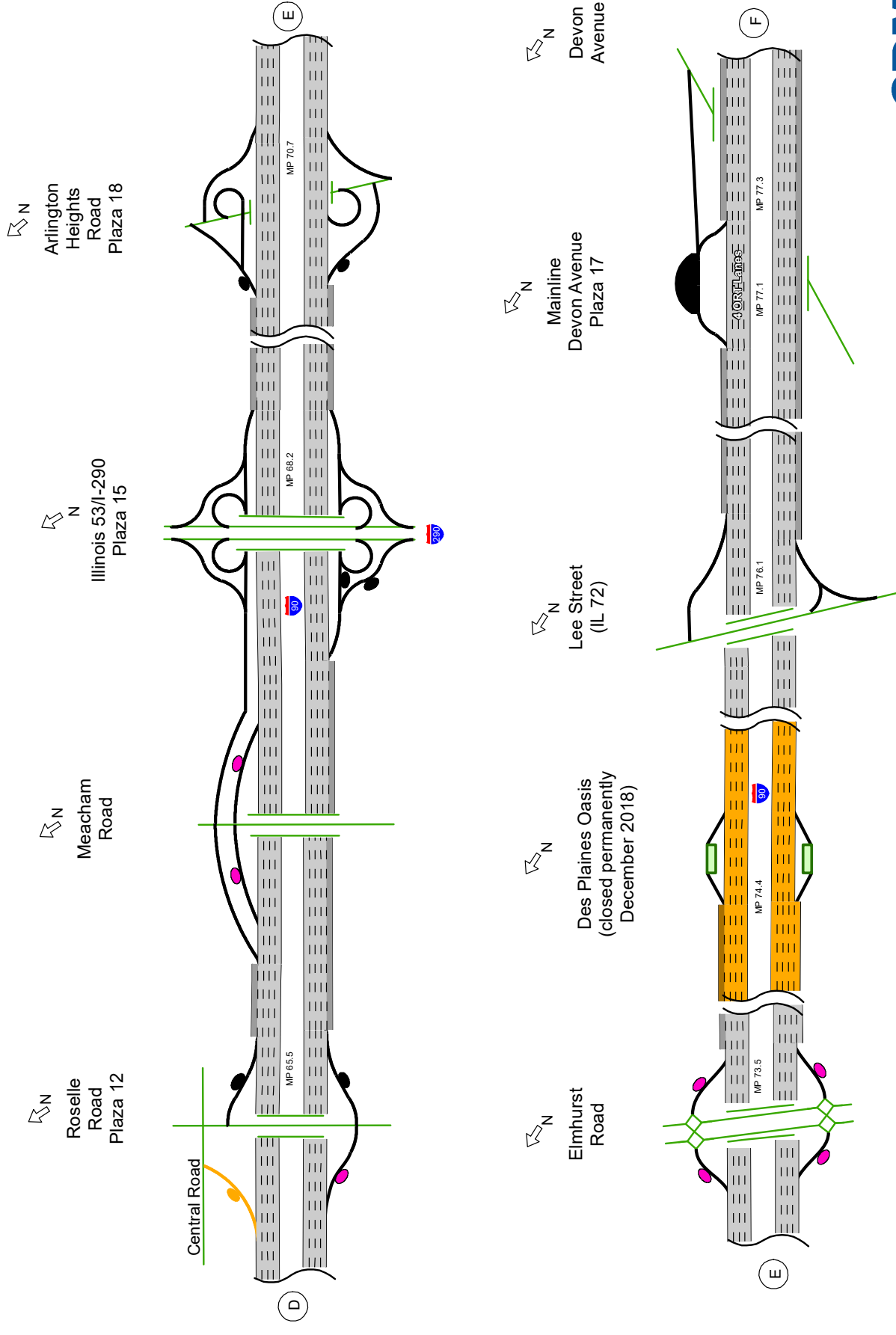



2018 Lane Configuration

On Jane Addams Memorial Tollway, from Tri-State Tollway to Kennedy Expressway

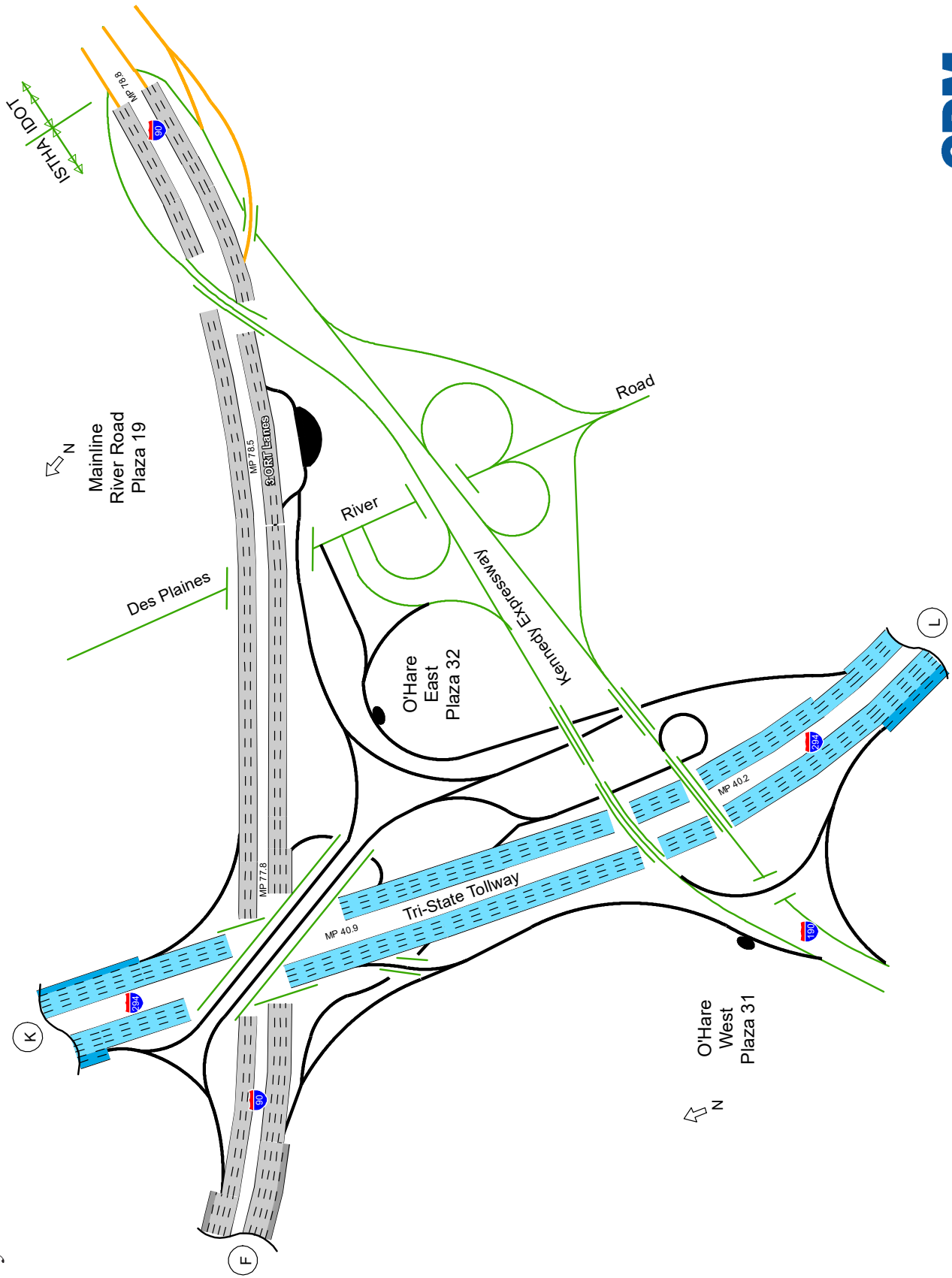

- Rehabilitation Project
- Construction Project





2018 Lane Configuration

On Tri-State Tollway, from Russell Road to Lake Forest Oasis

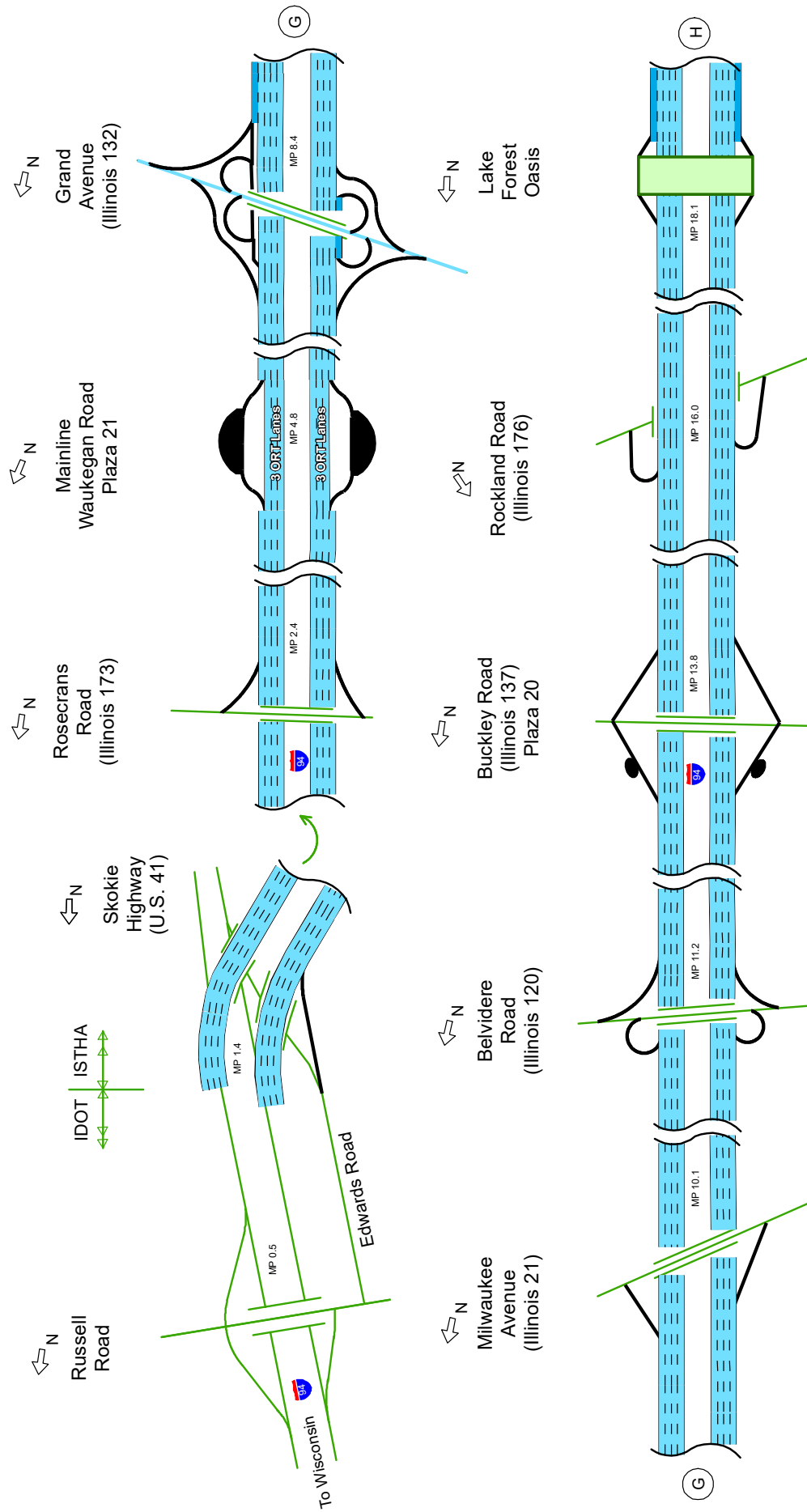



2018 Lane Configuration

On Tri-State Tollway, from Town Line Road (Illinois 60) to Golf Road (Illinois 58) and Edens Spur

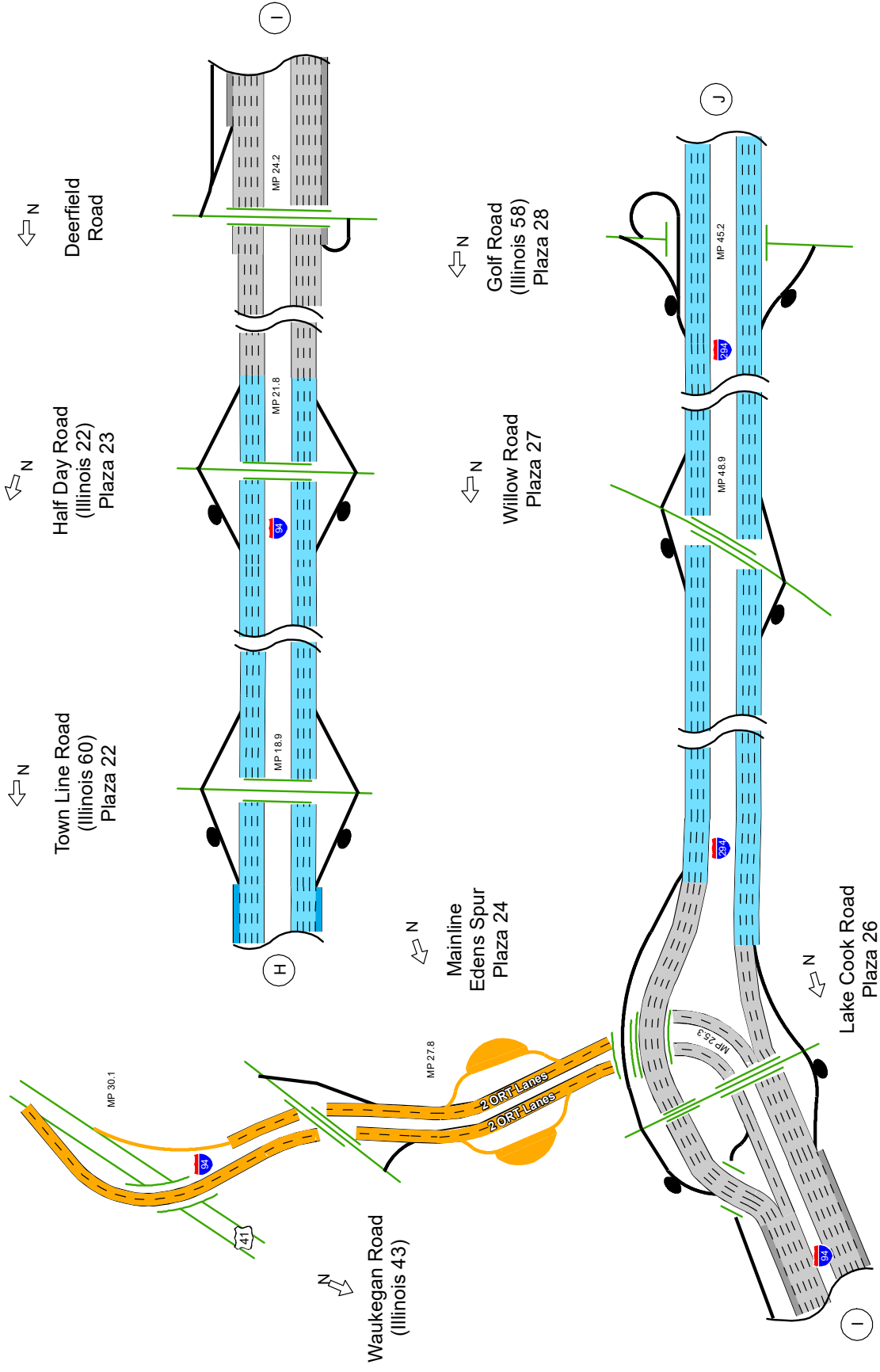

- Rehabilitation Project
- Construction Project





2018 Lane Configuration

On Tri-State Tollway, from Dempster Street to O'Hare Oasis

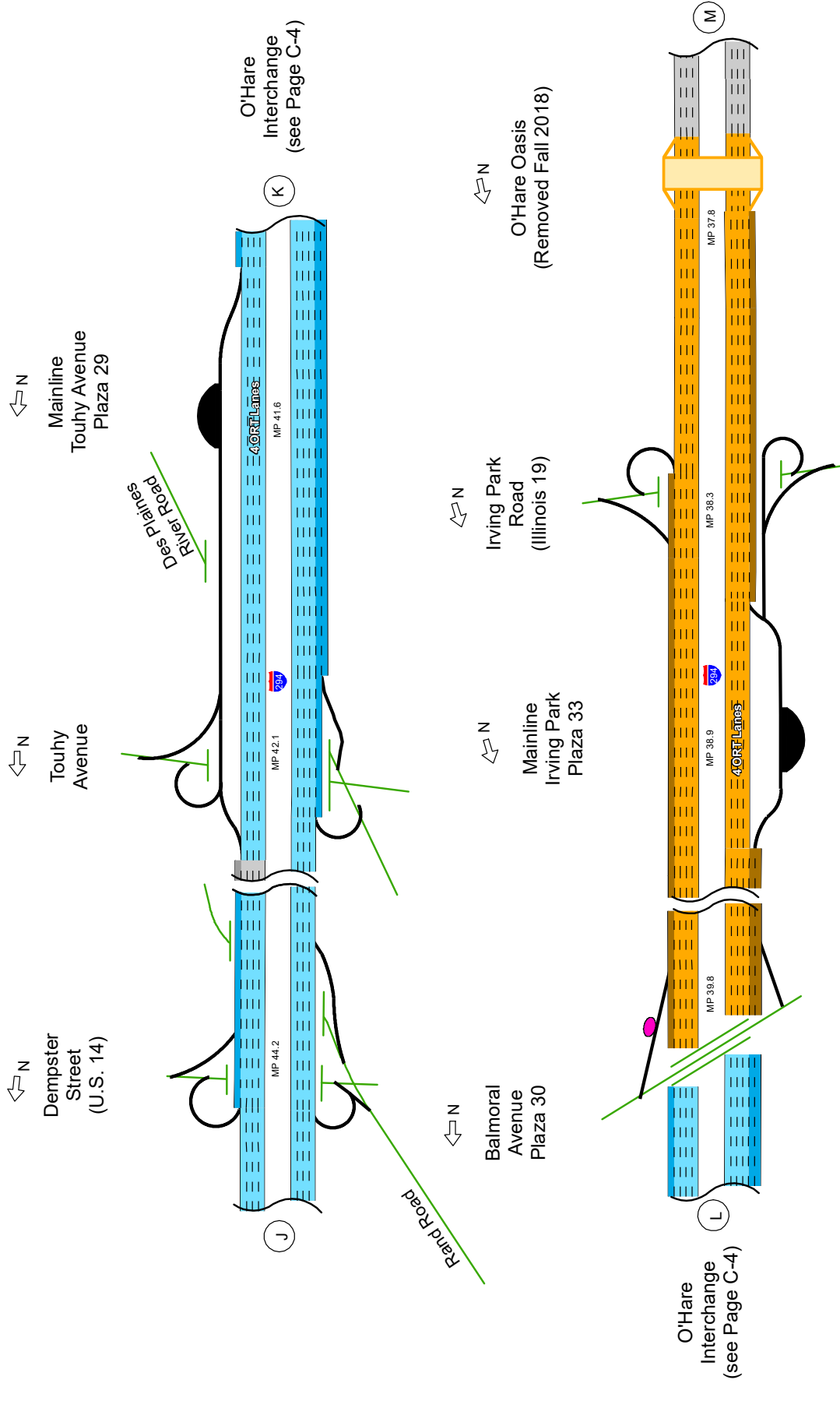

- Rehabilitation Project
- Construction Project





2018 Lane Configuration

On Tri-State Tollway, from North Avenue / Lake Street to Reagan Memorial Tollway (I-88)

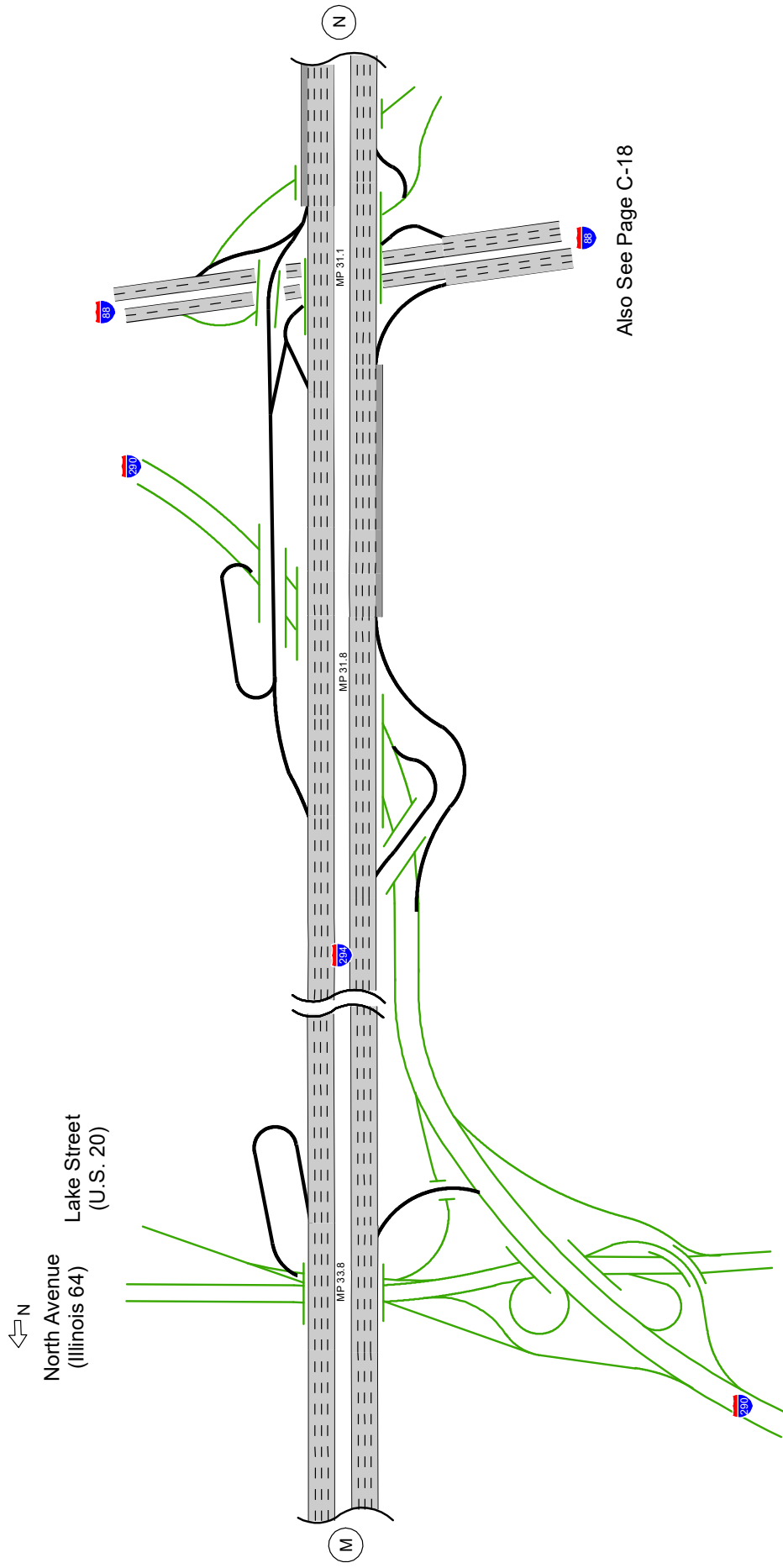

Also See Page C-18

- Rehabilitation Project
- Construction Project





2018 Lane Configuration

On Tri-State Tollway, from Roosevelt Road to Hinsdale Oasis

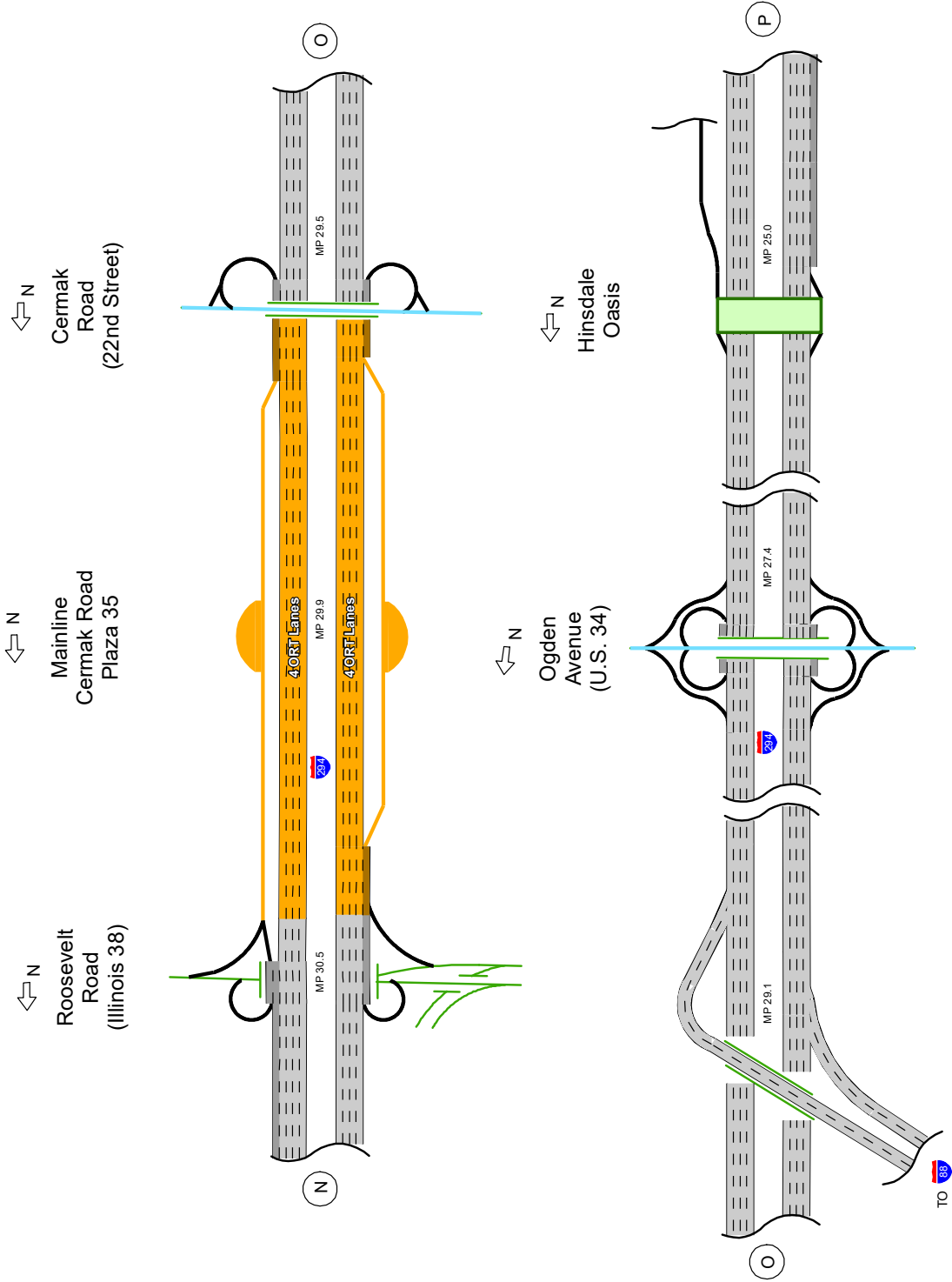

Also See Page C-17

- Rehabilitation Project
- Construction Project





2018 Lane Configuration

On Tri-State Tollway, from Joliet Road (Plaza 37) to Willow Springs Road (Plaza 34)

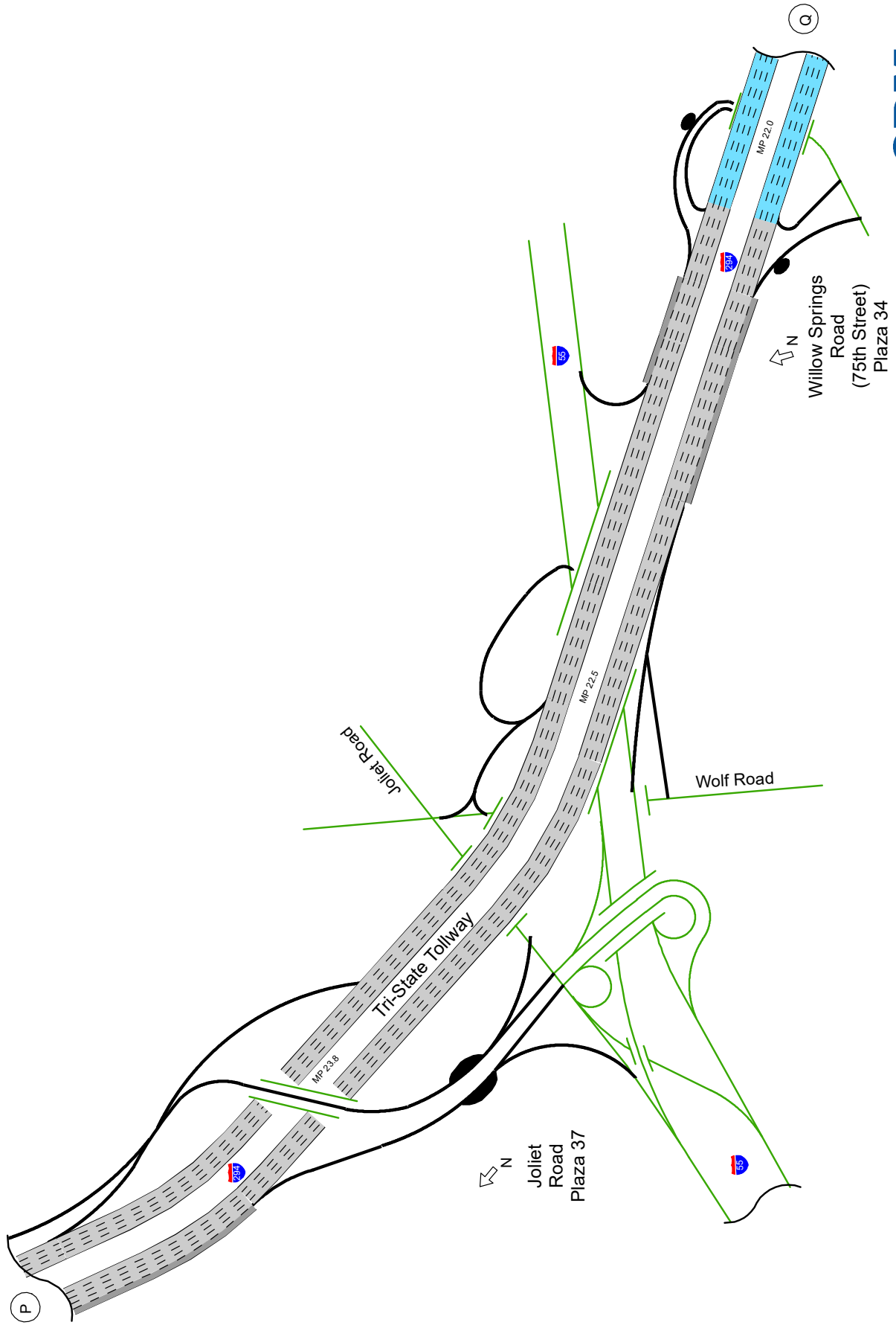

- Rehabilitation Project
- Construction Project





2018 Lane Configuration

On Tri-State Tollway, from 159th Street (Plaza 40) to Bishop Ford / Kingery Expressway

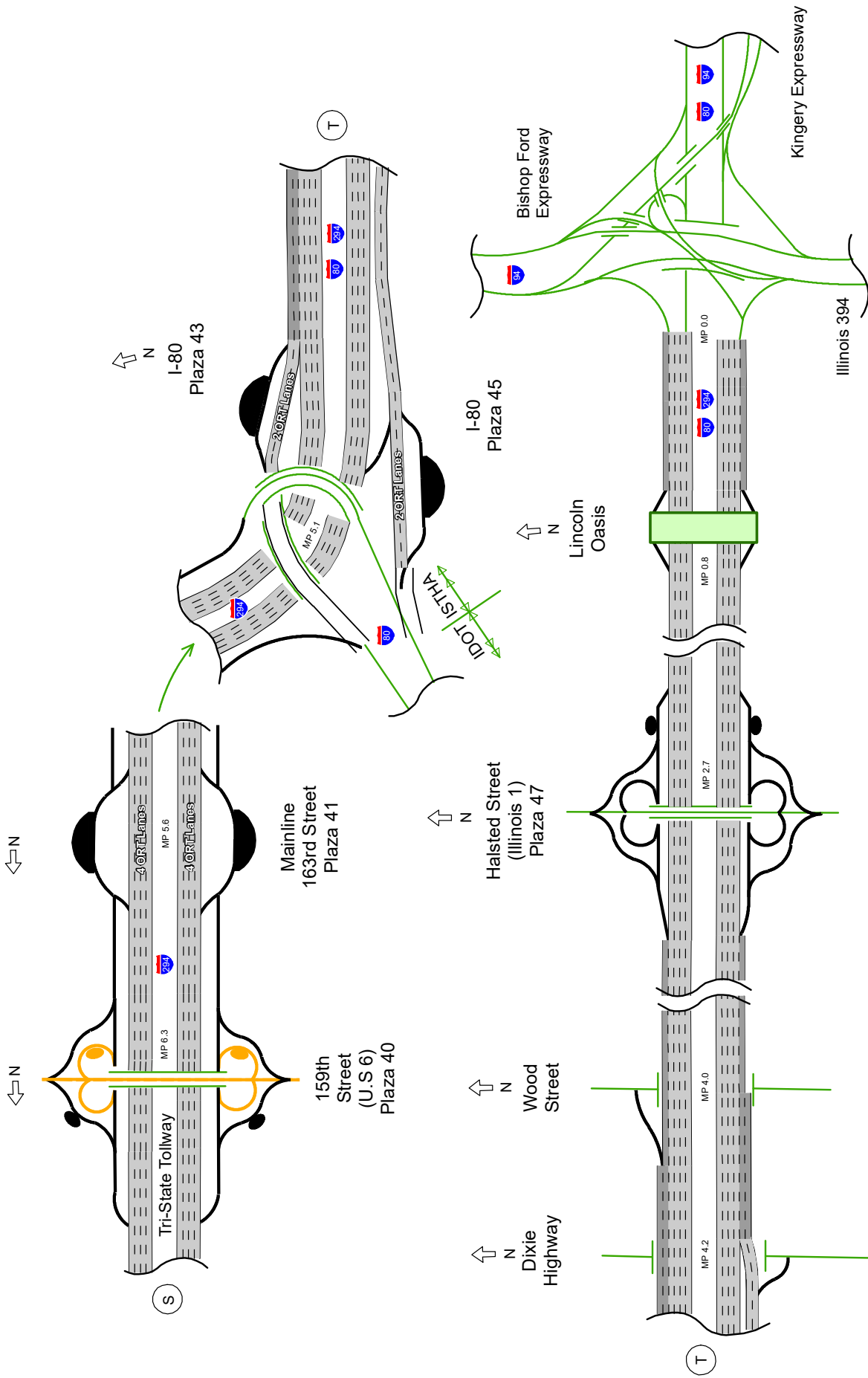



2018 Lane Configuration

On Reagan Memorial Tollway, from Illinois 31 to Illinois 53

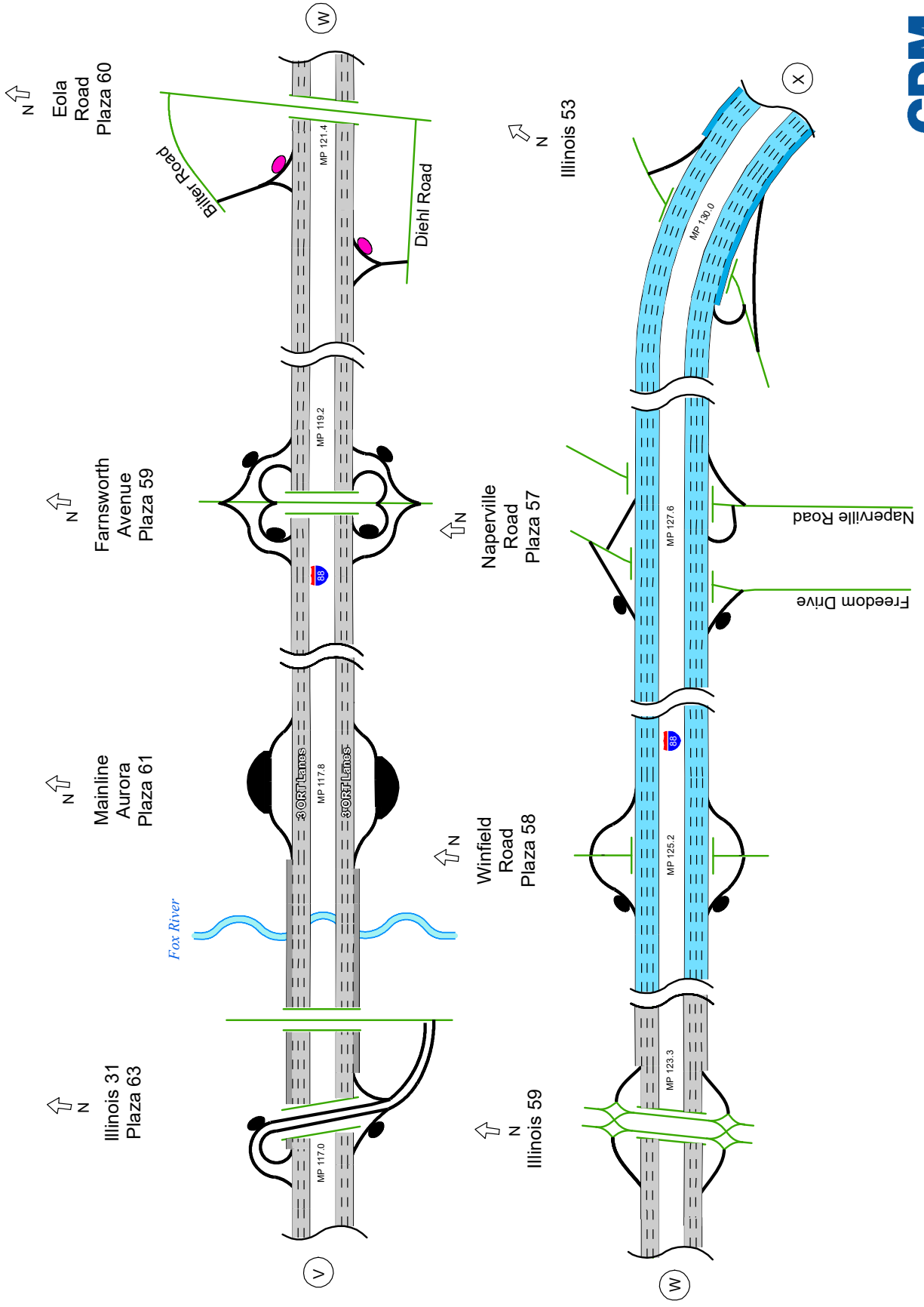

Rehabilitation Project
Construction Project





2018 Lane Configuration

On Reagan Memorial Tollway, Veterans Memorial Tollway West Interchange

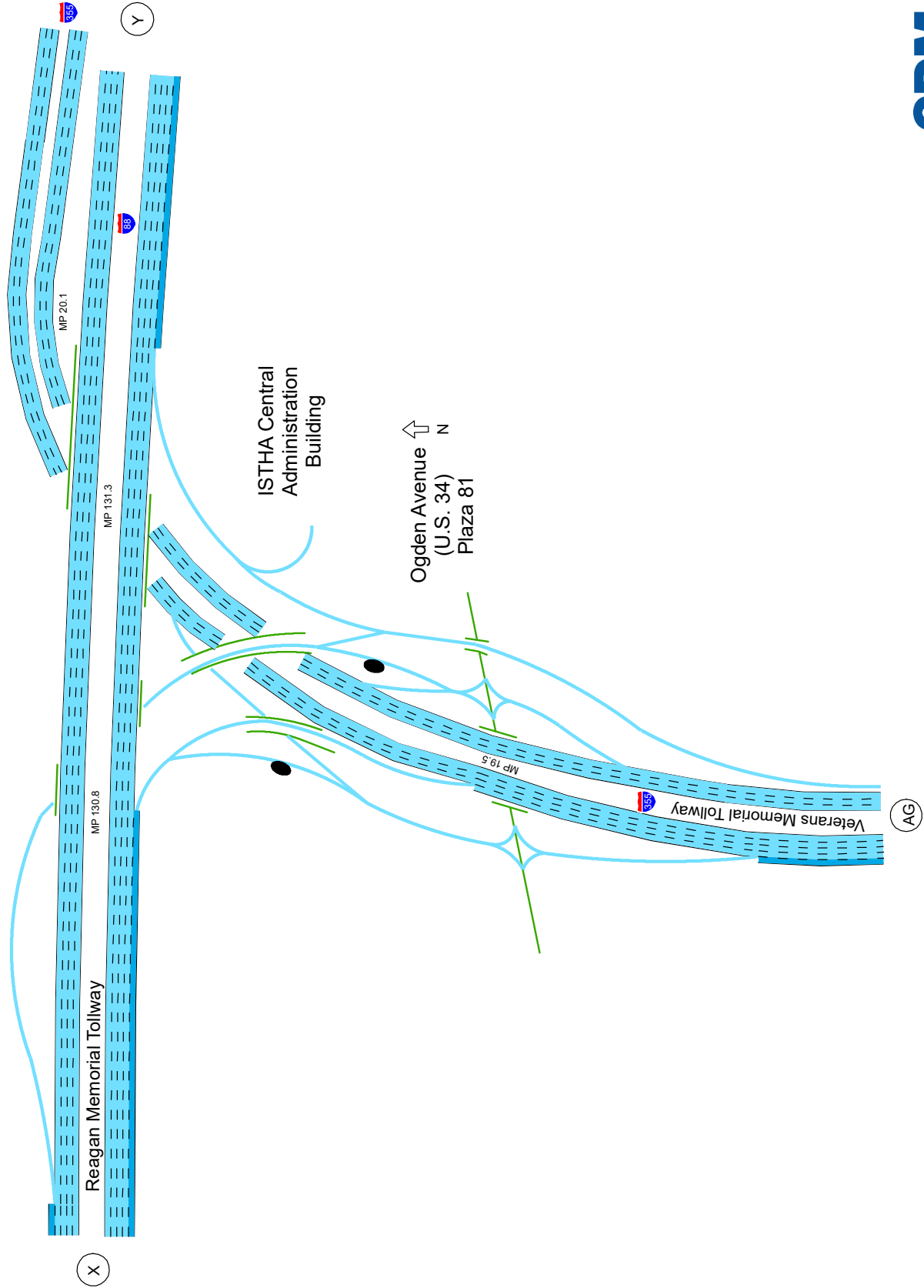

Rehabilitation Project
Construction Project



2018 Lane Configuration

On Reagan Memorial Tollway, Veterans Memorial Tollway East Interchange

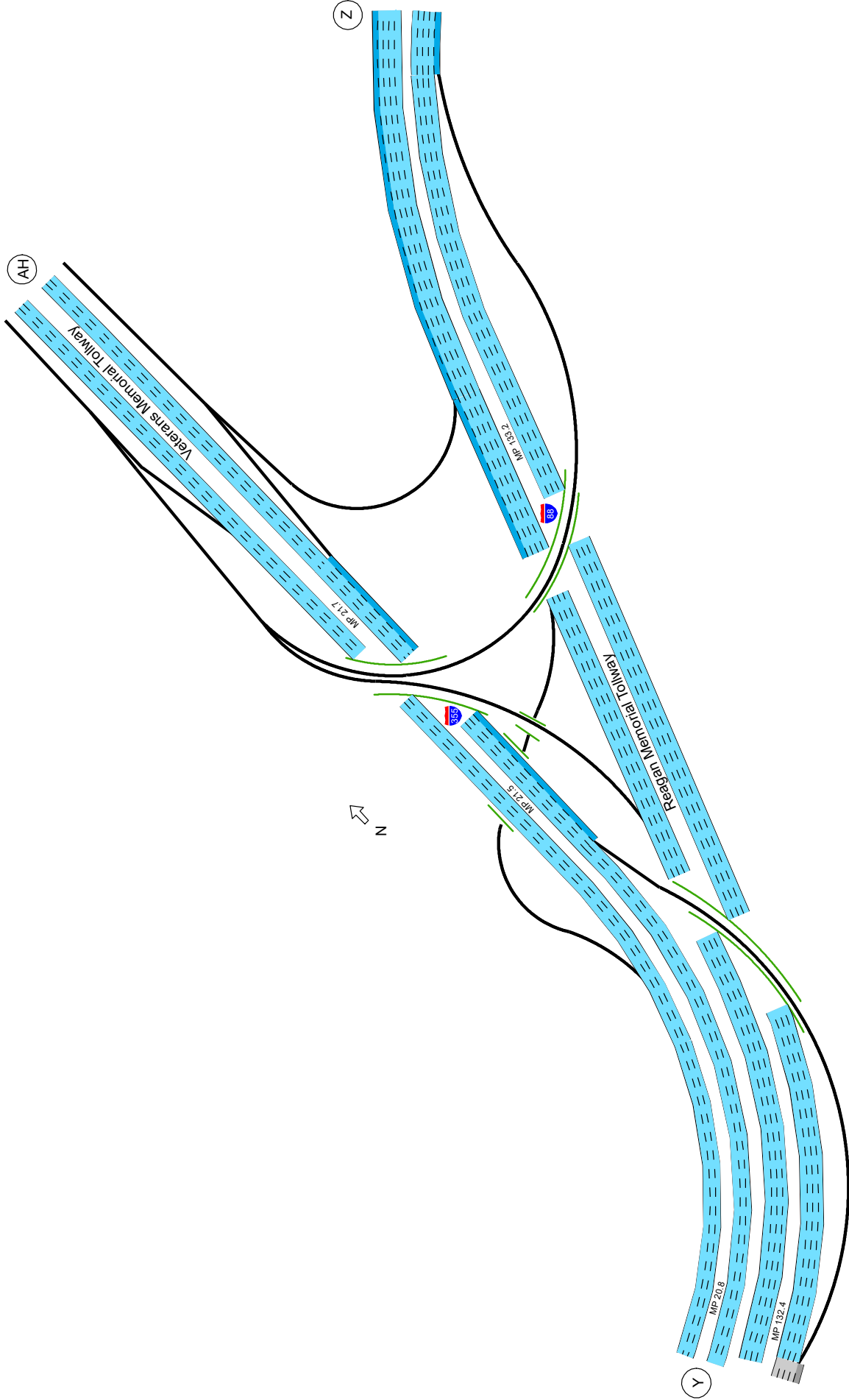



Rehabilitation Project
Construction Project

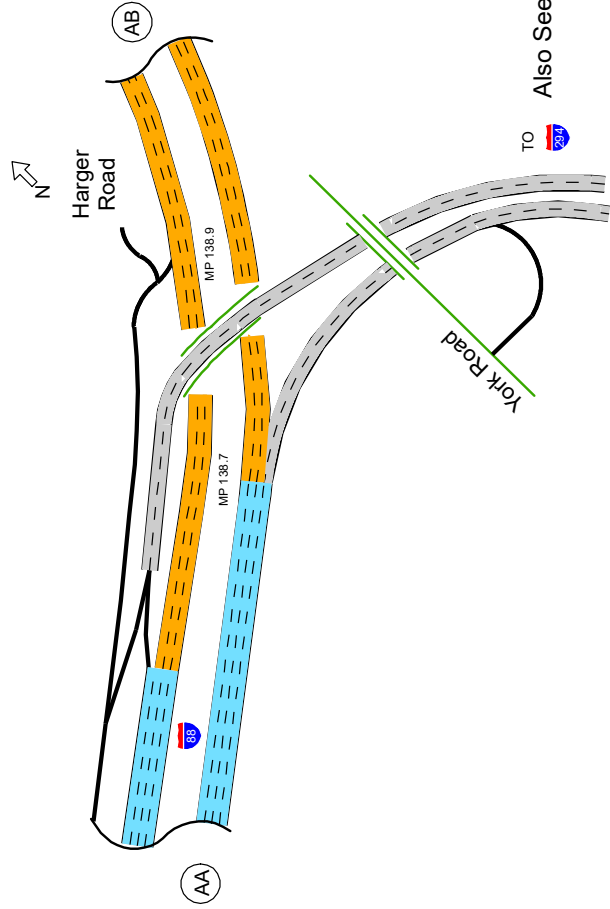
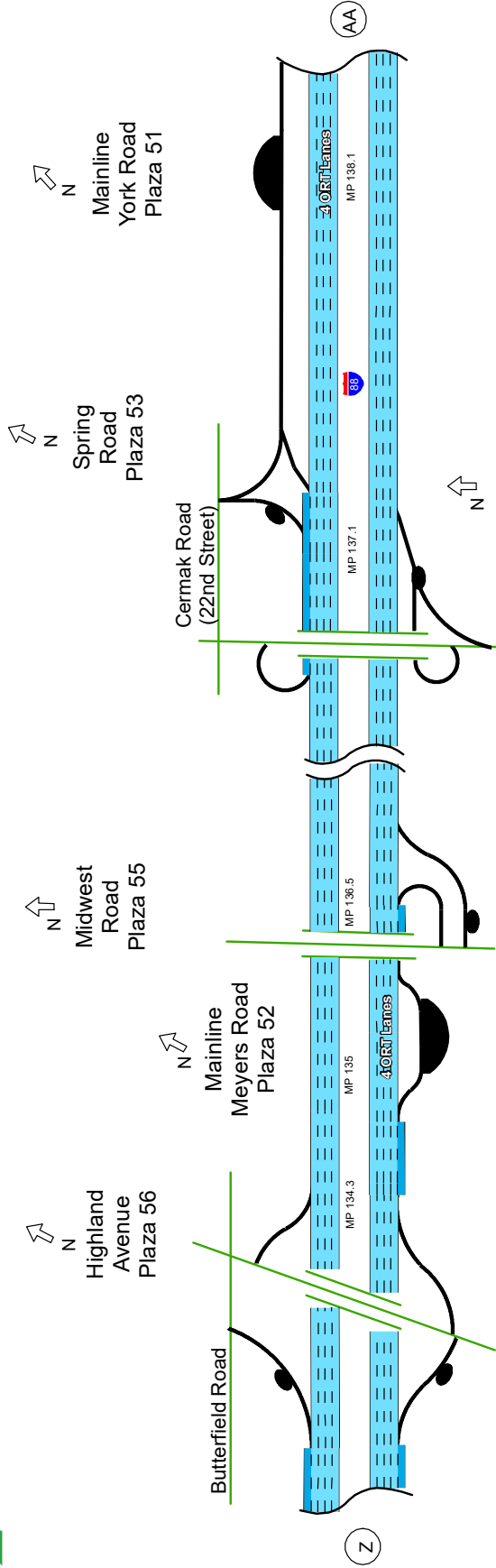

2018 Lane Configuration

On Reagan Memorial Tollway, from Highland Avenue to Harger Road



TO  Also See Page C-9

-  Rehabilitation Project
-  Construction Project





2018 Lane Configuration

On Reagan Memorial Tollway, from Roosevelt Road to Eisenhower Expressway (I-290)

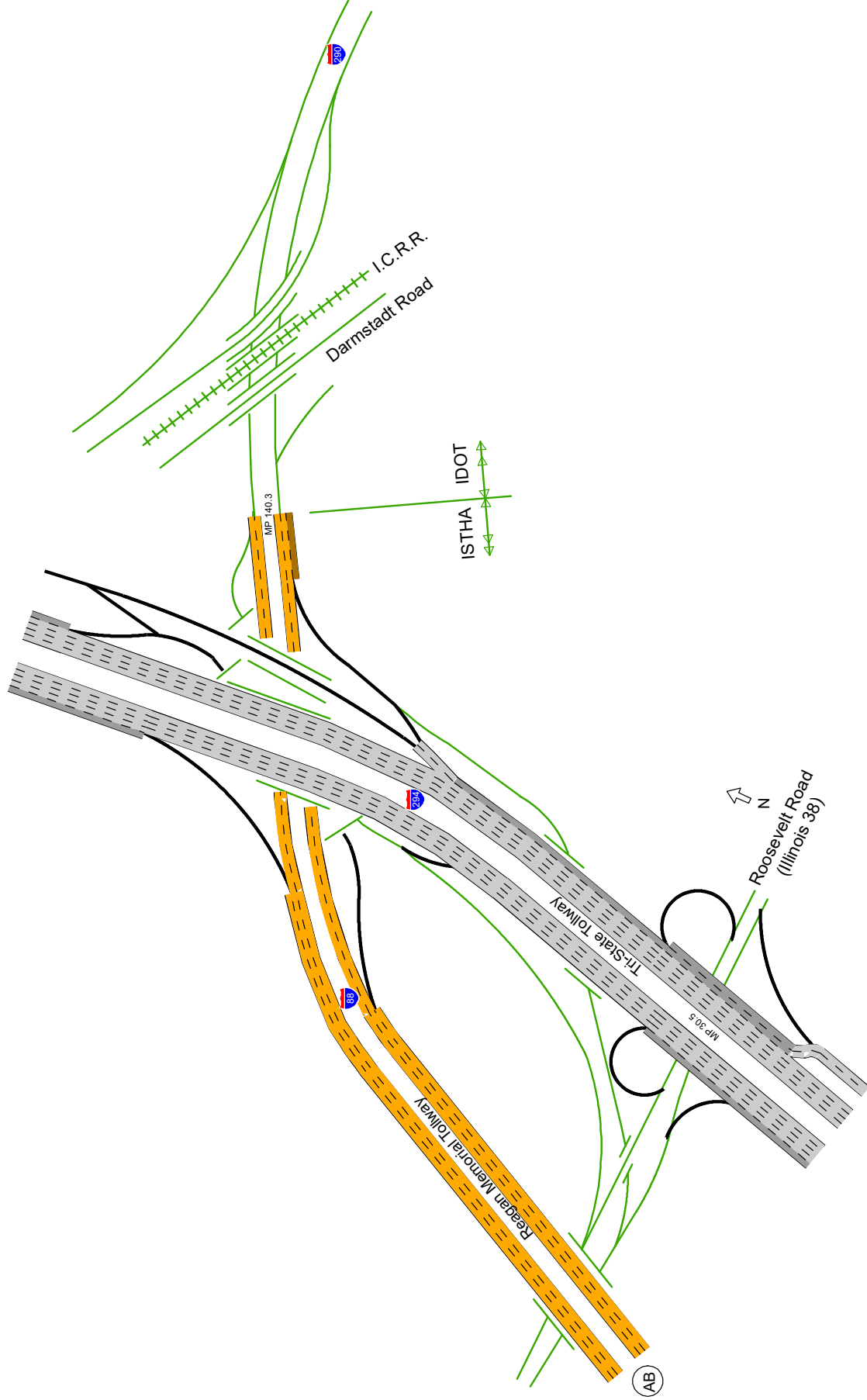

Rehabilitation Project
Construction Project





2018 Lane Configuration

On Veterans Memorial Tollway, from Interstate 80 to 127th Street

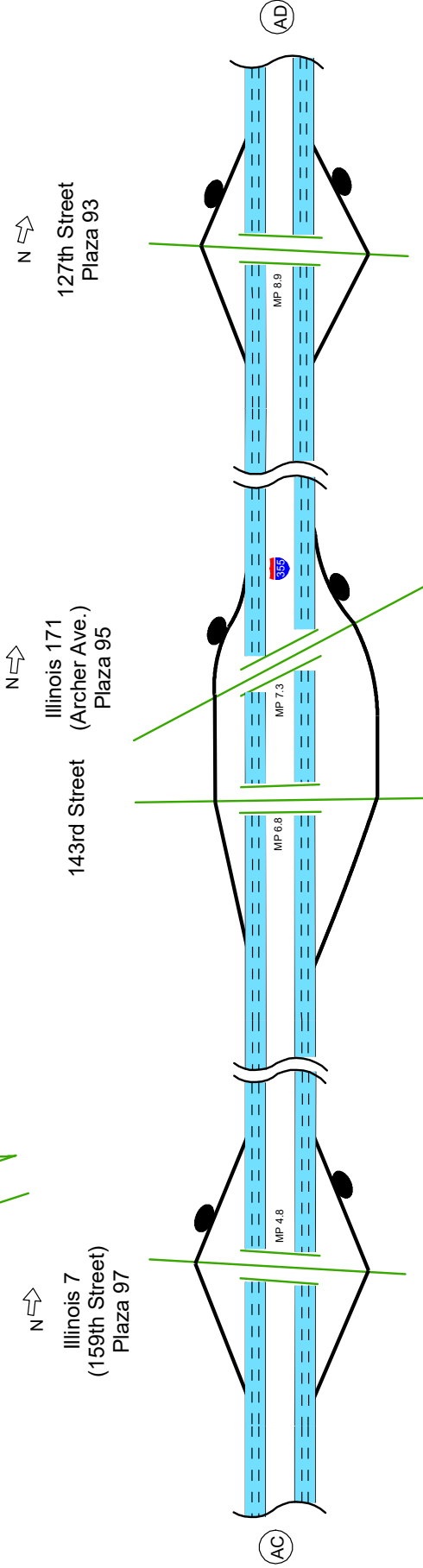
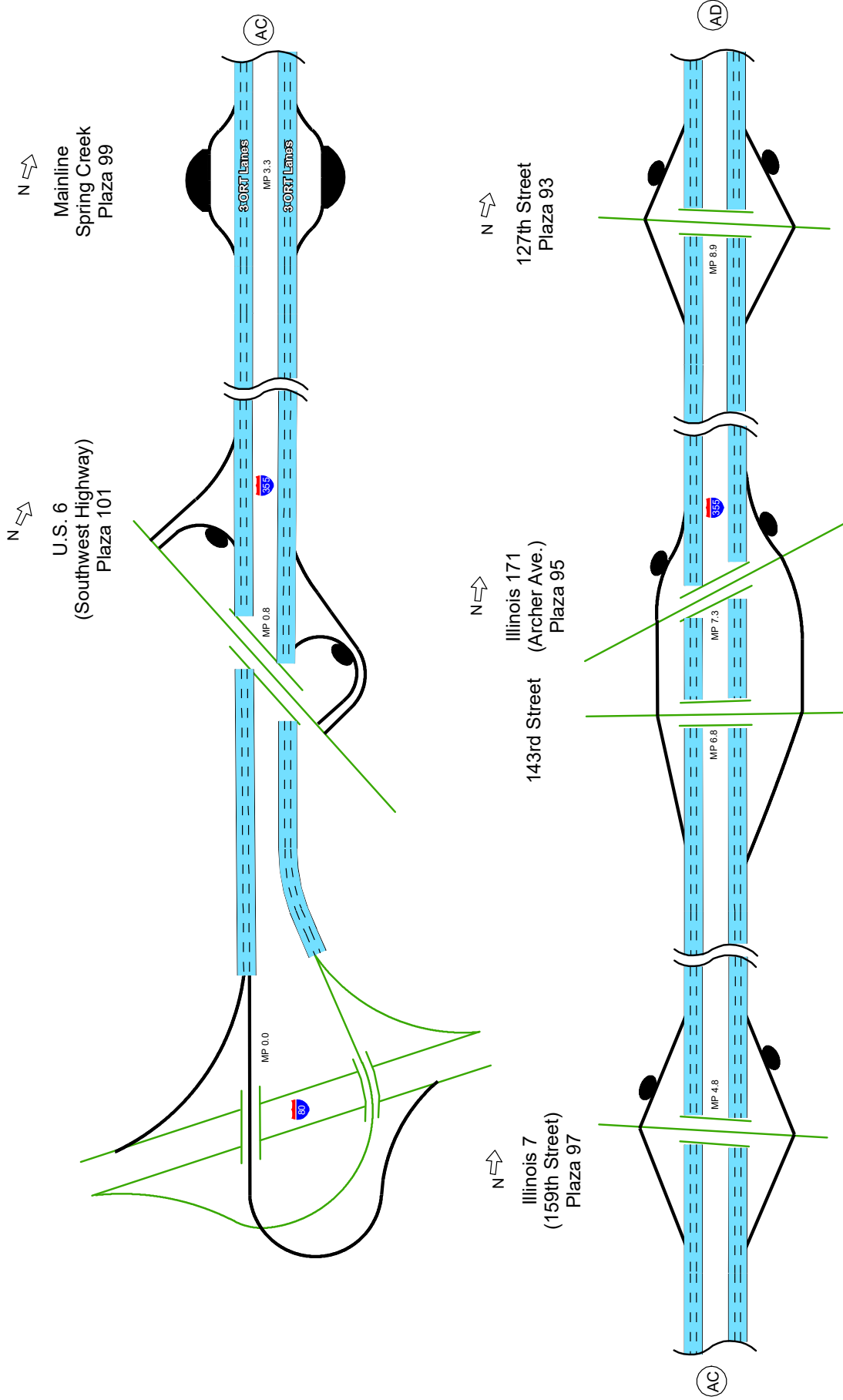

- Rehabilitation Project
- Construction Project





2018 Lane Configuration

On Veterans Memorial Tollway, At Interstate 55

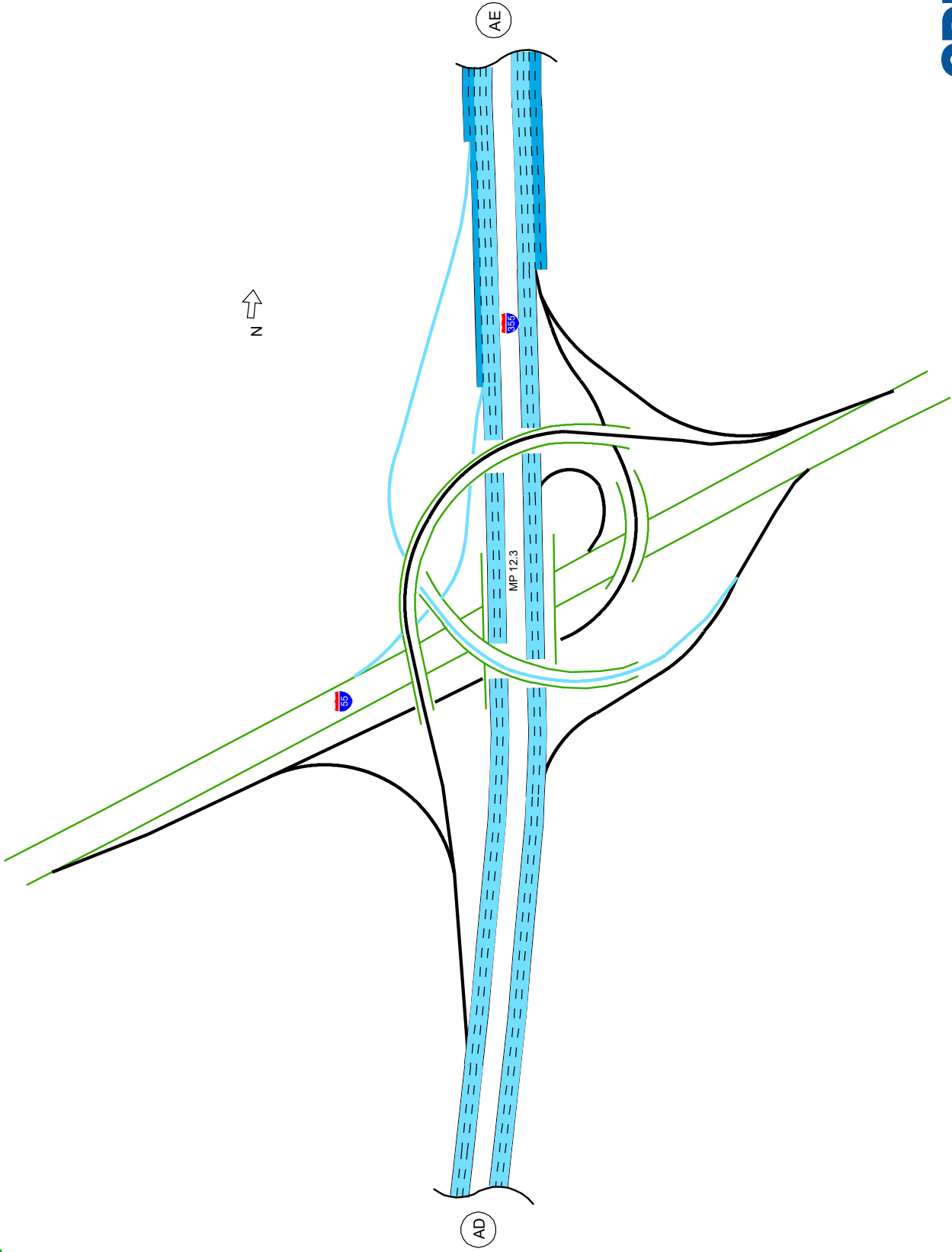

- Rehabilitation Project
- Construction Project





2018 Lane Configuration

On Veterans Memorial Tollway, from Boughton Road to Maple Avenue

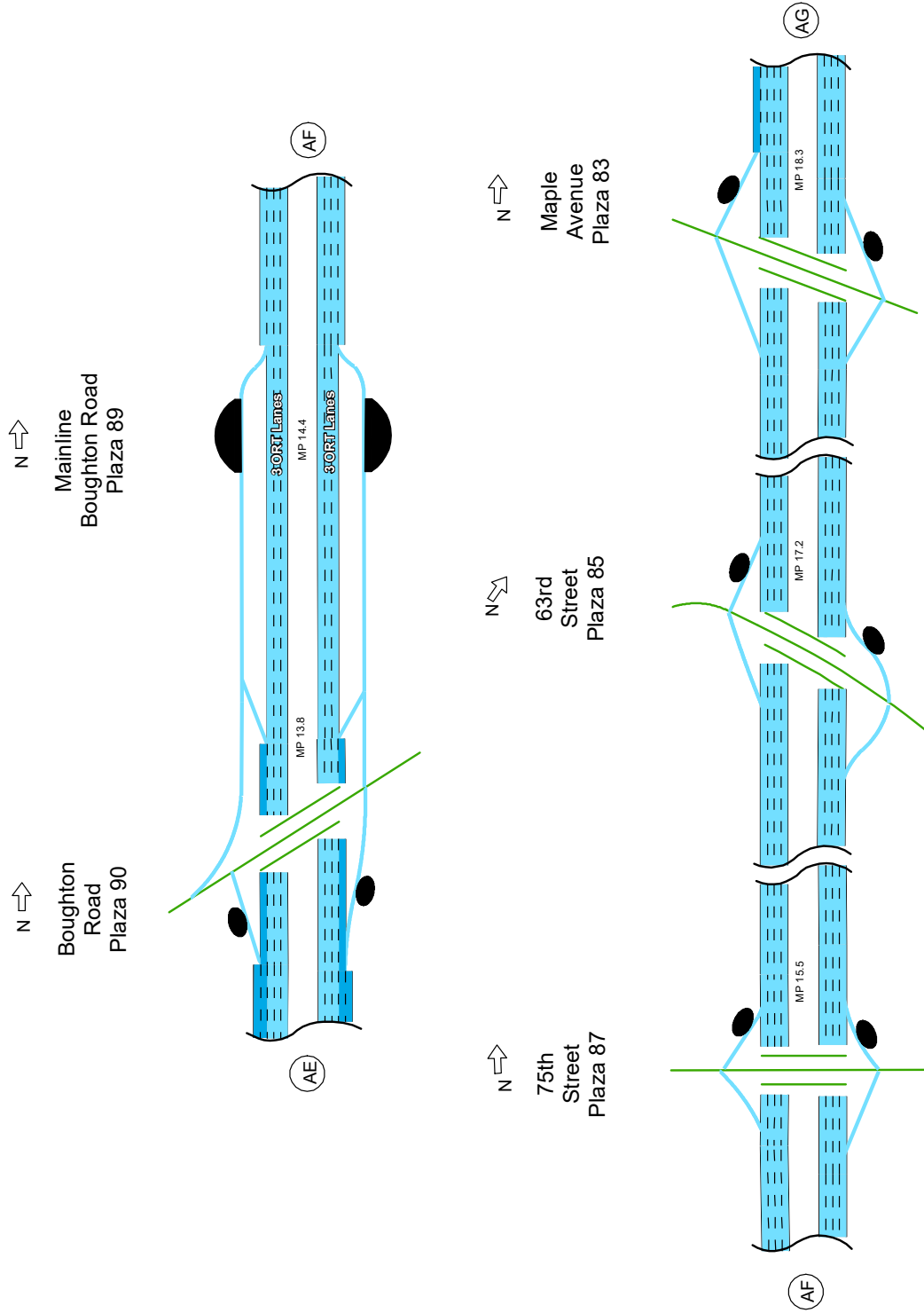

Rehabilitation Project
Construction Project





2018 Lane Configuration

On IL 390, from Lake Street to Plum Grove Road (Plaza 326)

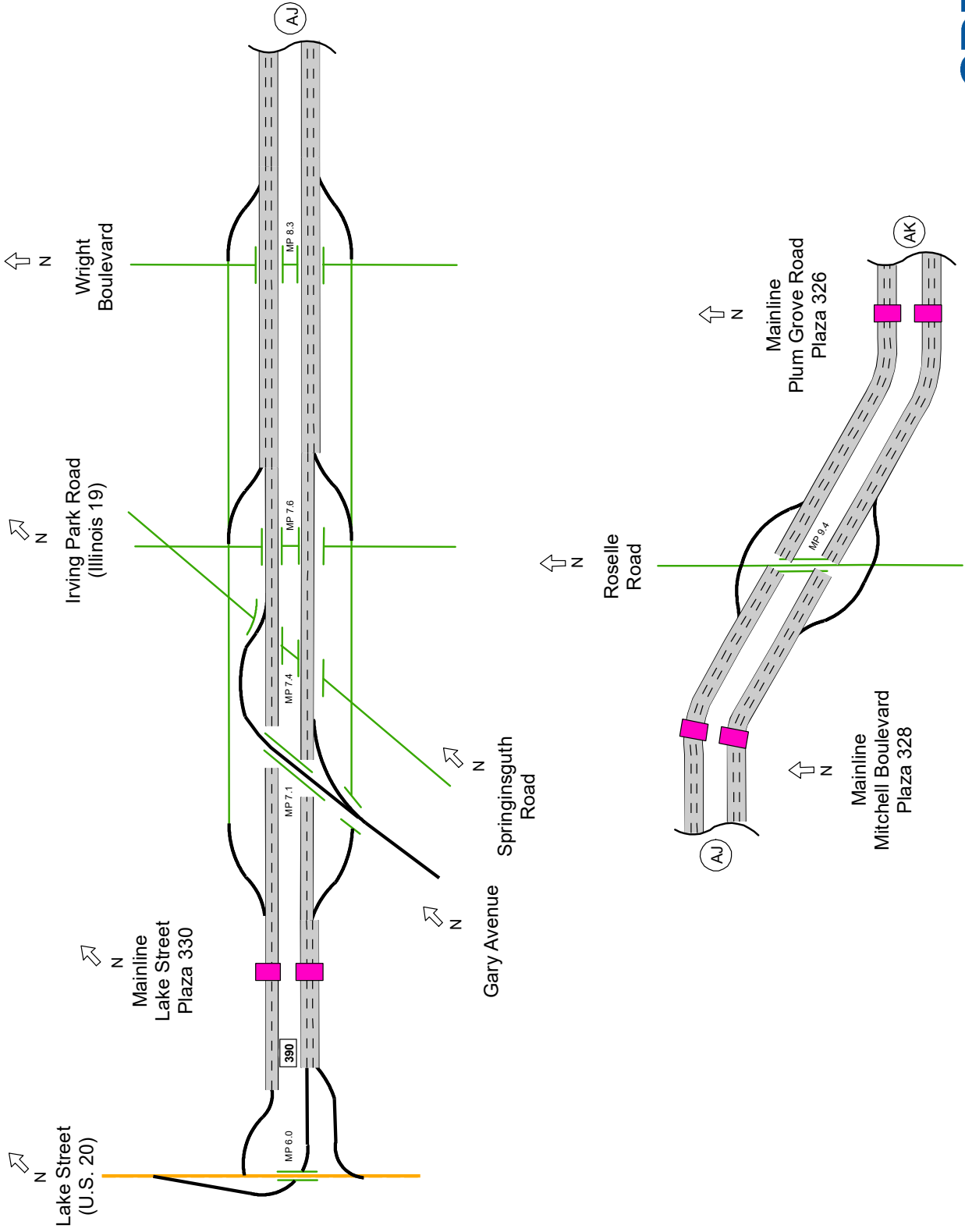

- Rehabilitation Project
- Construction Project





2018 Lane Configuration

On IL 390, from Plum Grove Road (Plaza 326) to Busse Road (Illinois 83)

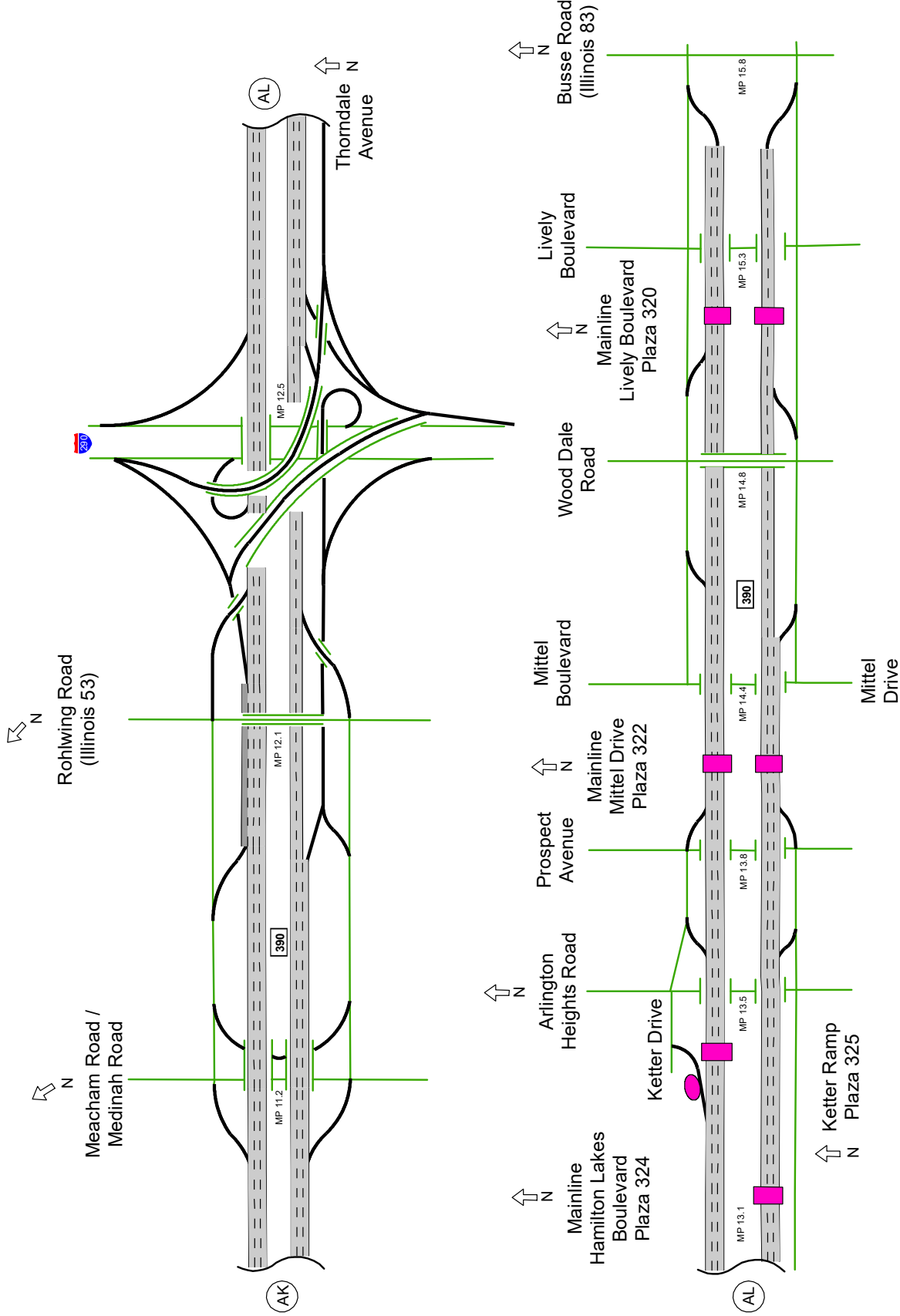

- Rehabilitation Project
- Construction Project





Appendix D

Plaza Lane Listing



JANE ADDAMS MEMORIAL TOLLWAY (I-90) PLAZA LANE CONFIGURATION AS OF 12-31-2018

No.	Name	Lane Number										Notes												
		EAST					WEST																	
1	South Beloit	71	72	73	74	75	51	52	53	54	55	61	62	63	64	65	81	82	83	84	85	Plaza building on east bound side		
5	Belvidere																					Serves WB traffic only. Plaza building located on west bound side.		
7	Marango-Hempshire	75	74				71	72	73	51	52	53	54	55								Serves EB only. Plaza building located on east bound side between lanes 71 & 74. Lanes 74 & 75 are seasonal lanes.		
9	Eglin	85	84	83	82	81	65	64	63	62	61	55	54	53	52	51	75	74	73	72	71	Plaza building located on west bound side.		
17	Devon Avenue											56	55	54	53	52	51	76	75	74	73	72	71	Serves WB traffic only. Plaza building located on west bound side.
19	River Road	71	72	73	74	75	76	77	51	52	53	54	55										Serves EB traffic only. Plaza building located on east bound side.	

No.	Name	Lane Number										Notes											
		EAST					WEST																
2	Riverside Boulevard						3	4				3	4				2	1				Lanes 1 & 2 exit I-90 WB to East River side Blvd. Lane 1 is eastmost. Lanes 3 & 4 enter I-90 EB from East Riverside Blvd.	
3	Genoa Road											2	61	62		51						Lanes 51 & 52 exit I-90 WB to Genoa Road. Lanes 61 & 62 exit I-90 EB to Genoa Road.	
4	Illinois Route 173											1	2			3	4					Lanes 3 & 4 exit I-90 WB to IL 173. Lanes 1 & 2 enter I-90 EB from IL 173.	
5A	Irene Road											51	52	53		61	62	61				Lanes 52 & 53 exit I-90 EB to Irene Road. Lanes 61 & 62 enter I-90 WB from Irene Road.	
6	Illinois Route 47						61	62	63			61	62	63		51	52	51				Lanes 54 & 55 enter I-90 WB. Lanes 51 & 53 exit I-90 WB to IL 47. Lanes 64 and 65 exit I-90 EB. Lanes 61 & 63 enter I-90 EB from IL 47.	
8	Randall Road											2	1			4	3					Lanes 1 & 2 exit I-90 EB to Randall Rd. Lanes 3 & 4 enter I-90 WB from Randall Rd.	
10	Barrington Road						52	51				52	51			4	3	2	1	61	62	63	Lanes 1, 2 & 3 exit I-90 WB to Barrington Rd. Lanes 61 & 62 enter I-90 WB from Barrington Rd. Lanes 4, 54 & 55 enter I-90 EB from Barrington Rd. Lanes 51 & 52 exit I-90 EB to Barrington Rd. Tolling on WB entrance and EB movement began in 2017.
11	Illinois Route 31											2	51	52		3	2	1	61	62	63	Lanes 1 & 5 exit I-90 WB to IL 31 NB. Lanes 2, 51 & 52 enter I-90 EB from IL 31 NB. Lane 3 enters I-90 EB from IL 31 SB. Lane 4 exits I-90 WB to IL 31 SB.	
12	Roselle Road						51	52				51	52			4	3	2	1	61	62	63	Lanes 1, 2 & 3 exit I-90 WB to Roselle Rd. Lanes 4, 54 & 55 enter I-90 EB from Roselle Rd. Lanes 51 & 52 exit I-90 EB to Roselle Rd. Lanes 61, 62, & 63 enter WB from Cental Rd. and opened November 2018.
12A	Meacham Road															61	63						Meacham Road tolled ramps opened November 2016. Lane 63 exit I-90 WB to Meacham Rd. Lane 61 enters I-90 WB from Meacham Rd.
13	Illinois Route 25																						Lanes 1 & 3 enter I-90 EB from IL 25. Lanes 2 & 4 exit I-90 WB to IL 25.
14	Illinois Route 59											3	1			4	2						Lanes 4 - 6 exit I-90 EB to IL 59. Lane 4 is closest to mainline.
15	I-290, Illinois Route 53											6	5	4		4							Lanes 1 & 2 exit I-90 EB to IL 53 NB. Lanes 4 - 7 exit I-90 EB to IL 53 SB. Lane 4 is closest to mainline.
16A	Illinois Route 59						7	6	5	4		1	2			2							Lanes 7 - 9 exit I-90 WB to IL 59. Lane 9 closest to mainline. Signed as 14 on plaza canopy.
16B	Beverly Road															9	8	7					Lanes 10 & 11 exit I-90 WB to Beverly Rd. Signed as 14A on plaza canopy. Lane 11 is closest to mainline.
18	Arlington Heights Road															11	10						Lanes 1 - 3 enter I-90 WB from Arlington Heights Rd. Lane 11 is northmost. Lanes 4 - 6 exit I-90 EB to Arlington Heights Rd.
18A	Elmhurst Road															3	2	1					Lanes 51 & 52 exit I-90 EB to Elmhurst Rd. Lanes 61 & 62 enter I-90 WB from Elmhurst Rd. Tolling began 2017.
																51	52	61					

	Count
Open Road/All Electronic Tolling (ORT/ET)	59
Manual Lane Toll (MLT)	34
Shoulder	24
I-PASS Only Lane (IPO)	30
Automatic Coin Machine Lane (ACM)	8
Automatic Toll Payment Machine Lane (ATPM)	18
Closed Lane/Other	2
II = Center Line/Main Line	-
Δ = Change in Movement/Direction	-





TRI-STATE TOLLWAY (I-94/I-294) PLAZA LANE CONFIGURATION AS OF 12-31-2018

Mainline Plaza No. Name	Lane Number										Notes											
	SOUTH/ EAST					NORTH/ WEST																
21 Waukegan	85	84	83	82	81	65	64	63	62	61	55	54	53	52	51	74	73	72	71	Plaza building located on east side.		
24 Edens Spur						71	72	73	74	51	52	53	54	61	62	63	64	81	82	83	84	Plaza building located on south side.
29 Touhy Avenue																						Serves NB traffic only. Plaza building located on east side.
33 Irving Park Road	71	72	73	74	75	76	77	51	52	53	54	55	56									Serves SB traffic only. Plaza building located on west side.
35 Cermak Road	87	86	85	84	83	82	81	66	65	64	63	62	61									Plaza building located on east side.
36 82nd Street	71	72	73	74	75	76	51	52	53	54	55	56										Serves SB traffic only. Plaza building located on west side.
39 83rd Street																						Serves NB traffic only. Plaza building located on east side. Lane 75 is temporarily IPO.
41 163rd Street	85	84	83	82	81	66	65	64	63	62	61											Main plaza building located on east side.

Ramp Plaza No. Name	Lane Number										Notes												
	SOUTH/ EAST					NORTH/ WEST																	
20 Buckley Road						4	3	2	1													Lanes 1 & 2 enter I-94 NB. Lane 1 is east most. Lanes 3 & 4 exit I-94 SB. Lane 4 is west most.	
22 To wline Road (L.60)											4	3	2	1								Lanes 1 & 2 enter I-94 NB. Lane 1 is east most. Lanes 3 & 4 exit I-94 SB. Lane 4 is west most.	
23 Half Day Road											4	3	2	1								Lanes 1 & 2 enter I-94 NB. Lane 1 is east most. Lanes 3 & 4 exit I-94 SB. Lane 4 is west most.	
26 Lake Cook Road											7	8	9	10	11	12							Lanes 10 - 12 enter I-294 NB. Lane 12 is east most. Lanes 7 - 9 exit I-294 SB. Lane 7 west most.
27 Willow Road											4	3	12	11	10	9							Lanes 9 - 11 enter I-294 NB. Lane 9 is east most. Lanes 12 - 14 exit I-294 SB. Lane 14 is west most.
28 Golf Road											6	5	4	3	2	1							Lanes 1 - 3 enter I-294 NB. Lane 1 is east most. Lanes 4 - 6 exit I-294 SB. Lane 6 is west most.
30 Balmoral Avenue																	53	52	51				Lanes 51-53 exit I-294 NB. Lane 53 is west most.
31 O'Hare West						1	2	3	4														Lane 1 is closest to the plaza building (northmost).
32 O'Hare East																	4	3	2	1			Lane 1 is closest to the plaza building (southmost).
34 75th Street											1	2	3	4	5	6							Lanes 1 - 3 exit I-294 SB. Lanes 4 - 6 enter I-294 NB.
37 I-55											1	2	3	4	5	6	7	8	9	10			Lanes 1 - 5 exit I-294 SB. Lane 1 is closest to the plaza building (west most). Lanes 6 - 10 enter I-294 NB. Lane 10 is east most.
38 95th Street																	4	3	2	1			Lanes 1 & 2 exit I-294 NB. Lane 1 is east most. Lanes 3 & 4 enter I-294 SB. Lane 4 is west most.
40 159th Street											8	7	6	5	4	3	4	1	2				Lanes 1 & 2 enter NB I-294 from WB 159th St. Lanes 3 & 4 enter NB I-294 from EB 159th St. Lanes 5 & 6 exit SB I-294 to EB 159th St. Lanes 7 & 8 exit SB I-294 to WB 159th St.
42 I-57 (interchange)											64	65	66	61	63	62	54	55	51	53	52	51	Lanes 52-53 enter NB I-294 from 147th Street. Lanes 55-56 enter NB I-294 from NB I-57. Lanes 61-62 exit SB I-294 to 147th Street. Lanes 65-66 exit SB I-294 to SB I-57.
43 I-80, Westbound																							Plaza to continue on I-80 WB from the southernmost portion of the Tri-State Tollway.
45 I-80, Eastbound											71	72	73	74	51	52	53	54					Plaza to enter the southernmost portion of the Tri-State Tollway from I-80 EB.
47 Halsted Street																							Lanes 1 - 3 exit NB I-294 to Halsted St. Lane 1 is closest to the control building (northmost). Lanes 4 - 6 enter SB I-294 from Halsted St.

	Count
Open Road/All Electronic Tolling (ORT/AET)	56
Manual Lane Toll (MLT)	63
Shoulder	33
I-PASS Only Lane (IPO)	47
Automatic Coin Machine Lane (ACM)	12
Automatic Toll Payment Machine Lane (ATPM)	22
Closed Lane/Other	4
I = Center Line/Main Line	-
Δ = Change in Movement/Direction	-





REAGAN MEMORIAL TOLLWAY (I-88) PLAZA LANE CONFIGURATION AS OF 12-31-2018

Mainline Plaza		Lane Number														Notes		
No.	Name	EAST							WEST									
51	York Road								51	52	53	54	55	56	57	58	59	Serves WB traffic only. Plaza building located on north side.
52	Meyers Road	71	72	73	74	75	76	77	60									Serves EB traffic only. Plaza building located on south side.
61	Aurora	71	72	73	74	75	76	77	61	62	63	64	65	66	67	68	69	Plaza building located on south side
66	DeKalb								61	62	63	64	65	66	67	68	69	Plaza building located on south side
69	Dixon								54	53	52	51	73	72	71			Plaza building located on north side
Ramp Plaza		Lane Number														Notes		
No.	Name	EAST							WEST									
53	Spring Road								1	2	3							All lanes enter I-88 WB from Spring Rd. Lane 1 is eastmost.
54	Illinois Route 83								1	2								All lanes enter I-88 EB from IL 83.
55	Midwest Road								1	2								All lanes enter I-88 EB from Midwest Rd.
56	Highland Avenue								4	3	2	1						Lanes 1 & 2 enter I-88 WB from Downers Dr. Lane 1 is westmost. Lanes 3 & 4 exit I-88 EB to Highland Ave. Lane 4 is southmost.
57	Naperville Road								1	2	3	4	5	6				Lanes 4 & 5 enter I-88 WB from Naperville Rd. Lanes 2 & 3 exit I-88 EB to Naperville Rd.
58	Winfield Road								5	6	7	8						Lanes 5 & 6 exit I-88 EB to Winfield Rd. Lane 5 is southmost. Lanes 7 & 8 enter I-88 WB from Winfield Rd. Lane 8 is southmost.
59	Farnsworth Avenue								7	3	1	4						Lanes 1 & 5 exit I-88 WB to NB Farnsworth Ave. Lane 2 enters I-88 EB from NB Farnsworth Ave. Lanes 3 & 7 enter I-88 EB from SB Farnsworth Ave. Lane 4 exits I-88 WB to SB Farnsworth Ave.
60	Eola Road								61	62	63	53	52	51				Lanes 52 & 53 exit I-88 WB to Blitzer Rd. Lane 53 is westmost. Lanes 62 & 63 enter I-88 EB from Diehl Rd. Lane 63 is westmost.
63	Illinois Route 31								2	1								Lane 1 enters I-88 WB from IL 31. Lane 2 exits I-88 EB to IL 31.
64	Orchard Road								3	4	2	1						Lanes 1 & 2 enter I-88 WB from Orchard Rd. Lane 2 is northmost. Lanes 3 & 4 exit I-88 EB to Orchard Rd. Lane 4 is southmost.
65	Peace Road								4	3	2	1						Lanes 1 & 2 exit I-88 WB to Peace Rd. Lane 1 is northmost. Lanes 3 & 4 enter I-88 EB from Peace Rd. Lane 4 is southmost.
67	Annie Glidden Road								1	2	3	4						Lanes 3 & 4 exit I-88 WB to Annie Glidden Rd. Lanes 1 & 2 enter I-88 EB from Annie Glidden Rd.

	Count
Open Road/All Electronic Tolling (ORT/AET)	26
Manual Lane Toll (MLT)	20
Shoulder	17
I-PASS Only Lane (IPO)	21
Automatic Coin Machine Lane (ACM)	6
Automatic Toll Payment Machine Lane (ATPM)	24
Closed Lane/Other	10
II = Center Line/Main Line	-
(A) = Change in Movement/Direction	-





VETERANS MEMORIAL TOLLWAY (I-355) PLAZA LANE CONFIGURATION AS OF 12-31-2018

No.	Name	Lane Number																		Notes					
		SOUTH									NORTH														
73	Army Trail	71	72	73	74	75	76	51	52	53	54	55	II	61	62	63	64	65	81	82	83	84	85	Plaza building located on west side.	
89	Boughton Road	71	72	73	74	75	76	51	52	53	54	55	II	61	62	63	64	65	81	82	83	84	85	86	Plaza building located on west side.
99	Spring Creek	83	82	81	65	64	63	62	61	II	55	54	53	52	51	73	72	71						Plaza building located on east side.	

No.	Name	Lane Number												Notes										
		SOUTH						NORTH																
75	North Avenue	6	5	4	II	3	2	1																Lanes 1-3 exit I-355 NB to North Ave. Lane 1 is east most.
77	Roosevelt Road								1	2	II	3	4											Lanes 1&2 enter I-355 SB from Roosevelt Rd. Lane 1 is closest to control building (west most). Lanes 3 & 4 exit I-355 NB to Roosevelt Rd. Lane 4 is east most.
79	Butterfield Road								1	2	II	3	4											Lanes 1&2 enter I-355 SB from Butterfield Rd. Lane 1 is closest to control building (westmost). Lanes 3 & 4 exit I-355 NB. Lane 4 is east most.
81	Ogden Avenue								1	2	II	3	4											Lanes 1&2 exit I-88 EB to Ogden Ave. Lane 1 is west most. Lanes 3 & 4 enter I-88 NB from Ogden Ave. Lane 4 is east most.
83	Maple Avenue								1	2	3	II	4	5	6									Lanes 1-3 exit I-355 SB to Maple Ave. Lane 1 is west most. Lanes 4-6 enter I-355 from Maple Ave. Lane 6 is east most.
85	63rd Street								6	5	4	II	3	2	1									Lanes 1-3 enter I-355 NB from 63rd St. Lane 1 is east most. Lanes 4-6 exit I-355 SB to 63rd St. Lane 6 is west most.
87	75th Street								6	5	4	II	3	2	1									Lanes 1-3 enter I-355 NB from 75th St. Lane 1 is east most. Lanes 4-6 exit I-355 SB to 75th St. Lane 6 is west most.
90	Boughton Road											1	2	II	3	4								Lanes 1&2 enter I-355 SB from Boughton Rd. Lanes 3&4 exit I-355 NB to Boughton Rd.
93	127th Street											1	2	II	3	4								Lanes 3&4 enter I-355 NB from 127th St. Lanes 1&2 exit I-355 SB to 127th St.
95	Archer Avenue											1	2	II	3	4								Lanes 3&4 enter I-355 NB from Archer Ave. Lanes 1&2 exit I-355 SB to Archer Ave.
97	159th Street											1	2	II	3	4								Lanes 3&4 enter I-355 NB from IL 7. Lanes 1&2 exit I-355 SB to IL 7.
101	U.S. Route 6								3	4	II	1	2											Lanes 3&4 enter I-355 SB from Route 6. Lanes 1&2 exit I-355 NB to US 6.

	Count
Open Road/All Electronic Tolling (ORT/AET)	18
Manual Lane Toll (MLT)	12
Shoulder	12
I-PASS Only Lane (IPO)	37
Automatic Coin Machine Lane (ACM)	0
Automatic Toll Payment Machine Lane (ATPM)	32
Closed Lane/Other	4
II = Center Line/Main Line	-
/ = Change in Movement/Direction	-





ILLINOIS ROUTE 390 TOLLWAY (IL 390) PLAZA LANE CONFIGURATION AS OF 12-31-2018

No.	Name	Lane Number																		Notes		
		SOUTH									NORTH											
Mainline Plaza		SOUTH									NORTH											
		71	72	73	74	75	76	77	78	79	80	81	82	83	84	85	86	87	88	89		
73	Army Trail																				Plaza building located on west side.	
89	Boughton Road																				Plaza building located on west side.	
99	Spring Creek																				Plaza building located on east side.	
Ramp Plaza		SOUTH									NORTH											
		6	5	4	3	2	1	<th>1</th> <th>2</th> <th>3</th> <th>4</th> <th>5</th> <th>6</th> <th> <th>1</th><th>2</th><th>3</th><th>4</th><th>5</th><th>6</th> <th></th> </th>	1	2	3	4	5	6	<th>1</th> <th>2</th> <th>3</th> <th>4</th> <th>5</th> <th>6</th> <th></th>	1	2	3	4	5	6	
75	North Avenue																					Lanes 1-3 exit I-355 NB to North Ave. Lane 1 is east most.
77	Roosevelt Road																					Lanes 1&2 enter I-355 SB from Roosevelt Rd. Lane 1 is closest to control building (west most). Lanes 3 & 4 exit I-355 NB to Roosevelt Rd. Lane 4 is east most.
79	Butterfield Road																					Lanes 1&2 enter I-355 SB from Butterfield Rd. Lane 1 is closest to control building (west most). Lanes 3 & 4 exit I-355 NB. Lane 4 is east most.
81	Ogden Avenue																					Lanes 1&2 exit I-88 EB to Ogden Ave. Lane 1 is west most. Lanes 3 & 4 enter I-88 WB from Ogden Ave. Lane 4 is east most.
83	Maple Avenue																					Lanes 1-3 exit I-355 SB to Maple Ave. Lane 1 is west most. Lanes 4-6 enter I-355 from Maple Ave. Lane 6 is east most.
85	63rd Street																					Lanes 1-3 enter I-355 NB from 63rd St. Lane 1 is east most. Lanes 4-6 exit I-355 SB to 63rd St. Lane 6 is west most.
87	75th Street																					Lanes 1-3 enter I-355 NB from 75th St. Lane 1 is east most. Lanes 4-6 exit I-355 SB to 75th St. Lane 6 is west most.
90	Boughton Road																					Lanes 1&2 enter I-355 SB from Boughton Rd. Lanes 3&4 exit I-355 NB to Boughton Rd.
93	127th Street																					Lanes 3&4 enter I-355 NB from 127th St. Lanes 1&2 exit I-355 SB to 127th St.
95	Archer Avenue																					Lanes 3&4 enter I-355 NB from Archer Ave. Lanes 1&2 exit I-355 SB to Archer Ave.
97	159th Street																					Lanes 3&4 enter I-355 NB from IL 7. Lanes 1&2 exit I-355 SB to IL 7.
101	U.S. Route 6																					Lanes 3&4 enter I-355 SB from Route 6. Lanes 1&2 exit I-355 NB to US 6.

	Count
Open Road/All Electronic Tolling (ORT/AET)	18
Manual Lane Toll (MLT)	12
Shoulder	12
I-PASS Only Lane (IPO)	37
Automatic Coin Machine Lane (ACM)	0
Automatic Toll Payment Machine Lane (ATPM)	32
Closed Lane/Other	4
J] = Center Line/Main Line	-
/ = Change in Movement/Direction	-





*Illinois
Tollway*