



2016  **Traffic Data Report**
FOR THE ILLINOIS TOLLWAY SYSTEM

2016 Traffic Data Report

For The Illinois Tollway System

Prepared for Illinois State Highway Authority



Prepared by: **CDM
Smith**

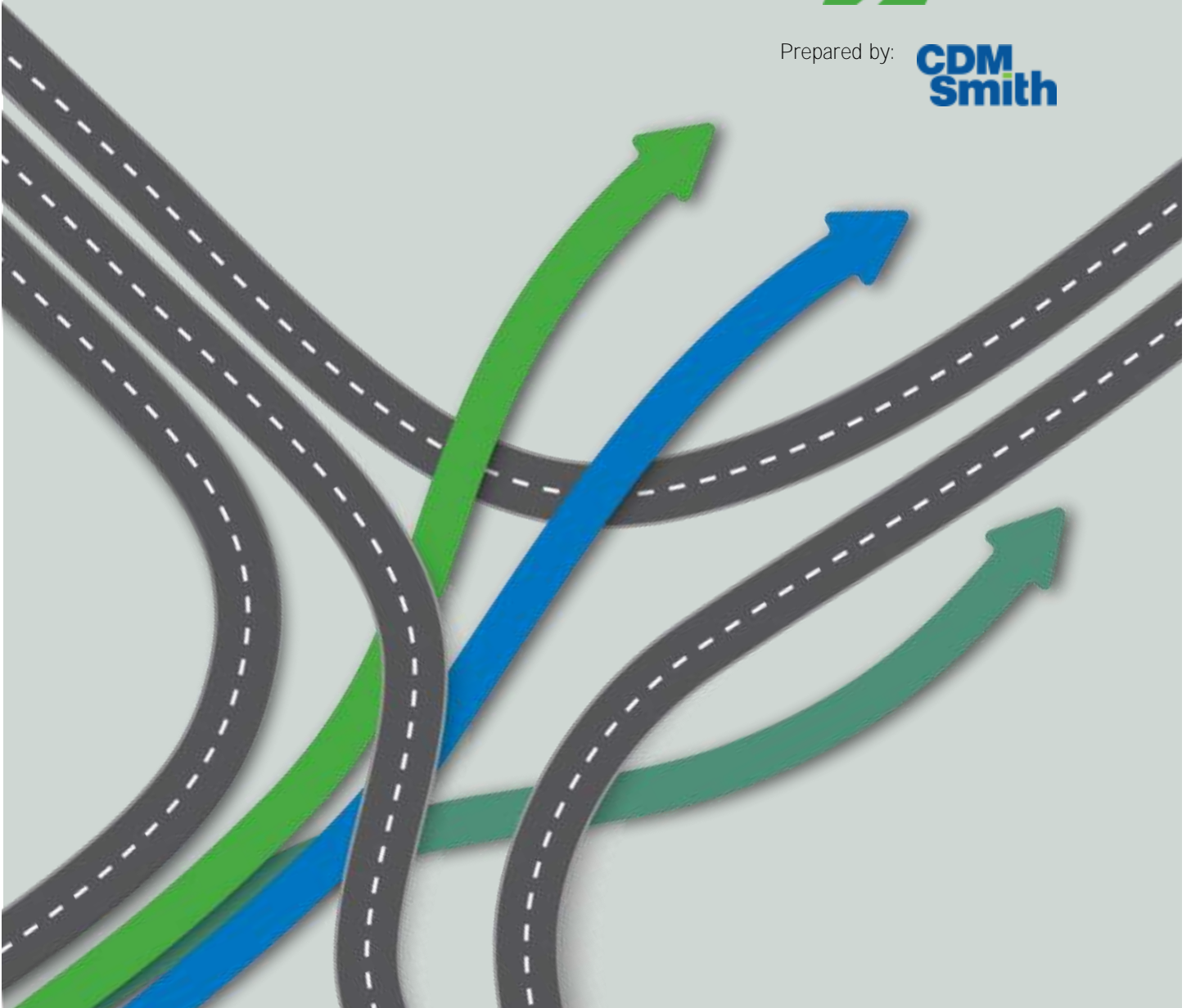



CONTENTS



SECTION 1: THE ILLINOIS TOLLWAY SYSTEM

SECTION 2: JANE ADDAMS MEMORIAL TOLLWAY

SECTION 3: TRI-STATE TOLLWAY

SECTION 4: REAGAN MEMORIAL TOLLWAY

SECTION 5: VETERANS MEMORIAL TOLLWAY

SECTION 6: ILLINOIS ROUTE 390 TOLLWAY

APPENDICES:

APPENDIX – A: 2016 SYSTEMWIDE ANNUAL AVERAGE DAILY
TRAFFIC SCHEMATICS

APPENDIX – B: 2016 SYSTEMWIDE AM AND PM PEAK HOUR
TRAFFIC SCHEMATICS

APPENDIX – C: 2016 LANE CONFIGURATION SCHEMATICS

APPENDIX – D: PLAZA LANE LISTING

(Please refer to individual sections for detailed Table of Contents)



Section 1

The Illinois Tollway System



SECTION 1

The Illinois Tollway System

General Information 1-2

TABULATIONS

TABLE	PAGE
1-A Systemwide Average Daily Traffic Data	1-7
1-B Annual Traffic Totals	1-8
1-C Average Daily Traffic Totals	1-8
1-D Systemwide Monthly Factors	1-8
1-E Annual Transactions by Vehicle 2015-2016	1-9
1-F I-PASS Participation Rate 2015-2016	1-9
1-G History of Tollway Additions by Mileage 1959 - 2016	1-10
1-H History of Tollway Additions by Location 1959 - 2016	1-11
1-I Summary of Traffic Characteristics at Plazas (Annual Transactions)	1-14

ILLUSTRATIONS

FIGURE	PAGE
1-A The Illinois Tollway System 2016	1-16
1-B Average Annual Daily Traffic 2016	1-17
1-C Average Annual Daily Traffic 1960	1-18
1-D Annual Average Percentage Change in Daily Traffic Volumes 2000 - 2016	1-19
1-E Annual Average Percentage Change in Daily Traffic Volumes 2010 - 2016	1-20
1-F Major Tollway Construction Projects During 2016	1-21
1-G Major Off-Tollway Construction Projects During 2016	1-22



GENERAL INFORMATION

The 2016 Traffic Data Report is intended to provide a snapshot of the average traffic conditions throughout the Tollway system for the year 2016. The primary sources of information for the development of this report are:

- Toll plaza transaction data
- Non-tolled ramp sample traffic counts
- Physical configuration of the Tollway system and connections to other routes
- Historical traffic data for the Tollway system.

The traffic volumes presented in this report for each segment of the system are primarily based on toll plaza transaction data. The data were extracted from the Electronic Transaction Consultants' Traffic Activity by Class Report and Hourly Traffic Volume Report run on January 23, 2017. Since transaction data is essentially continuous, accurate annual average daily traffic (AADT) and peak hour traffic volumes may be determined at mainline toll plazas and at tolled ramps. To obtain AADT and peak volumes in intermediate mainline segments and on non-tolled ramps, transaction data is supplemented by sample traffic counts conducted at non-tolled ramps. These sample counts are converted to AADT and peak volumes using seasonal adjustment factors and a balancing algorithm that adjusts non-toll ramp counts so that all mainline volumes are consistent with ramp exiting.

Conditions influencing local traffic flow frequently cause traffic volumes to vary from historical trends. While major traffic incidents or weather events can have a significant impact on the traffic on a particular day, use of annual averages tends to diminish these types of impacts. On the other hand, some events can have an effect on typical traffic volumes on a long-term basis. One such event was the passenger car toll rate change that took effect in 2012.

In 2011, the Tollway approved the \$12 billion *Move Illinois* capital program. To fund the program, passenger car rates were increased 87.5 percent on January 1, 2012 for both cash and I-PASS users. Systemwide, passenger car transactions declined 4.2 percent from 2011, largely due to the toll increase. Since then, passenger car transactions have increased by an average of 3.7 percent per year.

Any reconfiguration of the Tollway system, such as a new interchange or major capacity improvement, will have a permanent impact on traffic patterns. In July 2016, the Tollway began operating the Illinois Route 390 Tollway. Formerly an Illinois Department of Transportation (IDOT) route called the Elgin-O'Hare Expressway, the highway was improved by the Tollway starting in 2014. Illinois Route 390 connects U.S. 20/Lake Street in Hanover Park on the west with I-290/IL 53 on Itasca in the east and is primarily a commuter route. Three new mainline plazas on this facility recorded nearly 26 million transactions, over half of the growth from 2015 to 2016. Work continues to the east, where the route will be extended, eventually terminating at a proposed western bypass of O'Hare International Airport.

Major construction projects extending over many months also affect traffic volumes, causing a reduction in average traffic volumes on that route and increases in volumes on parallel routes. Most notably, traffic on the eastern Jane Addams Memorial Tollway dropped while undergoing major



construction in 2015 and 2016. Sections of the Illinois Tollway that were under significant construction in 2016 include:

ILLINOIS TOLLWAY SYSTEM

- Jane Addams Memorial Tollway (I-90/39)
 - Reconstruction/Widening – Elgin to Tri-State Tollway
 - Bridge Reconstruction – Tripp Road and Spring Center Road
 - Ramp Rehabilitation – U.S. Route 20
 - Bridge Reconstruction – Higgins Road in Gilberts
 - Bridge Rehabilitation – Randall Road
 - Interchange Reconstruction – Illinois Route 31
 - Bridge Reconstruction – Fox River Bridge
 - Interchange Reconstruction – Illinois Route 25
 - Bridge Reconstruction – Higgins Road (Illinois Route 72)
 - Interchange Reconstruction – Barrington Road
 - Interchange Construction – Roselle Road
 - New Interchange Construction – Meacham Road
 - Interchange Construction – Elmhurst Road
- Reagan Memorial Tollway (I-88)
 - Roadway Resurfacing – U.S. Route 30 to Illinois Route 251
 - Bridge Repairs – b/w U.S. Route 52 and IL Route 251, and at Reynolds Road
 - Bridge Construction & Interchange Improvements – Farnsworth Avenue
 - Ramp Rehabilitation – WB I-88 to Highland Avenue
- Veterans Memorial Tollway (I-355)
 - Roadway Widening & Ramp Reconstruction – 71st Street to s/o 75th Street
- Illinois Route 390 Tollway (IL 390)
 - New Construction – Lake Street (U.S. Route 20) to Illinois Route 83
 - Interchange Reconstruction – I-290

Off-system construction projects in the Tollway service area, particularly those on the expressway system, can also have a significant impact on Tollway traffic volumes. During 2016, construction projects with the potential to impact traffic on the Tollway system included the following:

IDOT EXPRESSWAY SYSTEM

- I-90 – Roadway Improvements – I-190 to Harlem Avenue
- I-290 & I-90/94 – Jane Byrne Interchange – I-90/94 at I-290
- I-55 – Interchange Reconstruction – U.S. Route 41
- Illinois Route 171 – Bridge Reconstruction – I-55

ARTERIALS

- Illinois Route 19 – Railroad Bridge Construction – York Road over Irving Park Road, Bensenville
- East River Road / Cumberland Flyover – Roadway Improvements – I-190 from O'Hare Airport to Cumberland Avenue, Chicago
- Torrence Avenue – Bridge Replacement – over Grand Calumet River, Chicago
- U.S. Route 20 – Interchange Reconstruction – McLean Boulevard, Elgin
- U.S. Route 14 – Reconstruction/Widening – s/o Illinois Route 176 to e/o Illinois Route 47, Crystal Lake
- U.S. Route 30 – Grade Separation over EJ&E/CN Railroad, Lynwood



- U.S. Route 30 – Reconstruction/Widening – I-55 to Illinois Route 59, Plainfield
- U.S. Route 34 (Ogden Avenue) – Grade Separation over EJ&E/CN Railroad, Aurora
- U.S. Route 6/Illinois Route 7 (159th Street) – Reconstruction – I-355 to U.S. Route 4, Orland Park
- 25th Avenue – Railroad Bridge Construction – St Charles Road to Lake Street (U.S. Route 20), Melrose Park
- U.S. Route 45 – Reconstruction/Widening – 131st Street to 179th Street, Cook County.

The listed projects may have caused variations in traffic patterns affecting Tollway traffic to varying degrees and may be positive or negative. These impacts are not individually quantified, but serve to illustrate the need for the reader to be cautious when using average daily or peak hour volumes from a single year.

TRAFFIC DEFINITIONS AS USED HEREIN

Traffic volumes are balanced over the entire system so that mainline and ramp volumes are consistent along a route; therefore the listed volumes are a precise numerical average only in locations where there is a toll plaza and complete data is available. Three types of traffic volumes are provided in this report and are defined below.

Annual Average Daily Traffic (AADT) Volume -- is an approximation of the numerical average daily traffic volume for each day of 2016.

AM Peak Hour Volume -- is an approximation of the 85th percentile hourly traffic volume in the highest AM hours (6:00-8:00 AM) on all Mondays through Thursdays in 2016, excluding holidays.

PM Peak Hour Volume -- is an approximation of the 85th percentile hourly traffic volume in the highest PM hours (4:00-6:00 PM) on all Mondays through Thursdays in 2016, excluding holidays.

Weekends – consist of Fridays, Saturdays, and Sundays that do not fall on holidays.

ROADWAY PERFORMANCE MEASURES

Roadway performance measures are used to illustrate congestion on the Illinois Tollway system. Performance measures are tabulated for all weekdays, Monday through Friday, including holidays. AM and PM peak hours are defined as 6:00-9:00 AM and 4:00-7:00 PM, respectively, for roadway performance measures. All calculations use travel time data purchased from INRIX. INRIX obtains speed and location data from a variety of Global Positioning System (GPS) devices, such as smart phone apps and in-vehicle navigation systems,. The 5-minute INRIX raw data and is aggregated it to 15-minute or 1-hour intervals for this report. Previously, roadway performance measures were calculated using travel times from I-PASS transaction data aggregated to the one-hour level. report is the first to use INRIX data. Roadway performance measure terms are defined below.

Average Travel Time Index – is the ratio of the average peak period travel time to an off-peak travel time (assumed to have a free-flow speed of 60 mph). For example, a value of 1.20 means that average peak travel times are 20% longer than off-peak (free-flow) travel times.

Planning Time Index – is the ratio of the total time needed to ensure 95% on-time arrival as compared to a free-flow travel time. For example, a value of 1.20 means that a traveler should budget an additional 4 minute buffer for a 20-minute average peak trip time to ensure 95% on-time arrival.



Total Delay – is a ratio of additional travel time spent by drivers, above the travel times required under free-flow conditions, to vehicle-miles traveled (measured in vehicle-hours/1,000 VMT).

Vehicle-Miles Traveled (VMT) – is the sum of distances traveled by all motor vehicles within a section of the Illinois Tollway.

Average Daily Delay – is the additional travel time spent by drivers, above the travel times required under free-flow conditions (measured in vehicle-hours).

Percent Congested Travel – is the ratio of congested vehicle-miles-traveled to total vehicle-miles-traveled. Congestion is defined as any one-hour time period in which the actual travel time is greater than the free-flow travel time.

The Tollway system is divided into eleven sections for reporting performance measures. They are described in the table below.

Section	Route Designation	Beginning Milepost	Ending Milepost
Eastern Jane Addams Memorial Tollway	I-90	54.6	79.1
Western Jane Addams Memorial Tollway	I-90/I-39	2.7	54.6
Northern Tri-State Tollway	I-94	1.2	30.0
North Central Tri-State Tollway	I-294	40.7	52.8
South Central Tri-State Tollway	I-294	24.1	40.7
Southern Tri-State Tollway	I-294	0.0	24.1
Eastern Reagan Memorial Tollway	I-88	116.8	140.4
Western Reagan Memorial Tollway	I-88	44.2	116.8
Northern Veterans Memorial Tollway	I-355	22.6	29.8
Central Veterans Memorial Tollway	I-355	12.3	22.6
Southern Veterans Memorial Tollway	I-355	0.0	12.3
Illinois Route 390 Tollway	IL 390	6.0	12.5

OTHER DEFINITIONS

30th Hourly Volume (30th HV) – is the 30th highest hourly volume occurring at a plaza during 2016, regardless of day or time.

PC – Passenger Cars. Motorcycles and two-axle, four wheeled vehicles are considered passenger cars.

CV – Commercial Vehicles. All vehicles with more than four wheels, including passenger cars towing trailers are considered commercial vehicles.



HOLIDAYS AND DAYS WITH UNCHARACTERISTIC TRAFFIC PATTERNS

Due to differing traffic patterns, major holidays are classified separately from weekdays and weekends. Additionally, the day immediately preceding some holidays are considered holidays for the purpose of this report due to their unusual traffic characteristics.

Below is a list of holidays and their dates in 2016.

New Years	Friday, January 1
Memorial Day	Friday, May 27
	Monday, May 30
Independence Day	Monday, July 4
Labor Day	Friday, September 2
	Monday, September 5
Thanksgiving	Wednesday, November 23
	Thursday, November 24
	Friday, November 25
Christmas	Sunday, December 25
	Monday, December 26
New Years	Saturday, December 31



TABLE 1-A: SYSTEM WIDE AVERAGE DAILY TRAFFIC DATA

Year	Average Daily Total			Average Trip
	Vehicles	Vehicle Miles	Transactions	Length (miles)
1959	62,321	1,753,465	117,637	28.14
1960	87,358	2,346,638	160,973	26.86
1961	109,731	2,659,991	194,577	24.24
1962	132,668	2,985,415	222,322	22.50
1963	134,818	2,878,143	211,939	21.35
1964	138,876	2,971,427	217,831	21.40
1965	158,170	3,303,069	247,469	20.88
1966	172,263	3,705,230	283,152	21.51
1967	186,379	3,973,250	313,648	21.32
1968	206,449	4,376,634	368,342	21.20
1969	238,245	4,821,981	440,997	20.24
1970	254,586	5,180,119	485,214	20.35
1971	279,326	5,669,283	533,241	20.30
1972	303,014	5,892,861	561,173	19.45
1973	342,322	6,353,650	621,905	18.56
1974	349,315	6,450,658	637,824	18.47
1975	369,435	6,780,810	666,002	18.35
1976	404,502	7,356,671	723,102	18.19
1977	431,215	7,850,792	770,872	18.21
1978	465,613	8,392,536	824,085	18.02
1979	479,525	8,685,523	851,116	18.11
1980	472,518	8,578,161	842,742	18.15
1981	493,226	8,846,114	866,299	17.94
1982	500,961	8,820,131	869,866	17.61
1983	527,505	9,273,782	906,308	17.58
1984	544,532	9,779,084	958,999	17.96
1985	587,614	10,283,396	1,008,812	17.50
1986	629,278	11,295,635	1,102,413	17.95
1987	672,160	11,689,569	1,172,861	17.39
1988	721,177	12,902,373	1,269,782	17.89
1989	745,381	13,323,423	1,307,767	17.87
1990	896,699	14,672,385	1,487,801	16.36
1991	946,112	14,913,846	1,547,094	15.76
1992	993,920	15,290,401	1,572,740	15.38
1993	1,034,054	15,612,752	1,607,475	15.10
1994	1,041,362	17,231,387	1,732,312	16.55
1995	1,088,510	18,271,480	1,827,959	16.79
1996	1,123,270	18,878,017	1,890,858	16.81
1997	1,193,230	19,316,298	1,941,011	16.19
1998	1,218,030	19,550,833	1,984,130	16.05
1999	1,247,410	20,374,456	1,972,261	16.33
2000	1,277,940	20,647,836	2,011,583	16.16
2001	1,322,130	21,431,414	2,088,631	16.21
2002	1,337,005	22,274,640	2,153,241	16.66
2003	1,363,990	22,791,808	2,196,240	16.71
2004	1,404,110	23,382,734	2,249,030	16.65
2005	1,344,410	22,381,137	2,138,209	16.65
2006	1,333,990	22,184,397	2,093,494	16.63
2007	1,412,430	22,775,523	2,159,704	16.13
2008	1,382,450	22,005,034	2,125,361	15.92
2009	1,381,050	21,951,844	2,124,254	15.90
2010	1,402,290	23,363,833	2,238,582	16.66
2011	1,422,040	23,713,815	2,287,292	16.68
2012	1,379,220	22,776,184	2,196,121	16.51
2013	1,401,090	23,251,182	2,235,730	16.60
2014	1,420,440	23,741,315	2,296,656	16.71
2015	1,475,930	25,006,490	2,415,385	16.94
2016	1,575,670	25,905,518	2,618,430	16.44

Average Daily Vehicles and Average Trip Length have been restated for 2010-2015.

TABLE 1-B: ANNUAL TRAFFIC TOTALS

Tollway Route	Vehicles	Vehicle Miles			Transactions
		PC	CV	Total	
Jane Addams Memorial	113,771,100	1,750,861,730	311,738,224	2,062,599,954	171,409,067
Tri-State	242,581,140	3,627,430,116	649,216,932	4,276,647,048	412,383,995
Reagan Memorial	91,701,300	1,653,753,114	243,052,866	1,896,805,980	152,909,963
Veterans Memorial	102,157,920	1,015,364,553	115,471,137	1,130,835,690	169,586,596
Illinois Route 390	13,024,800	52,064,921	4,261,726	56,326,647	25,601,207
Total	563,236,260	8,099,474,434	1,323,740,885	9,423,215,319	931,890,828

TABLE 1-C: AVERAGE DAILY TRAFFIC TOTALS

Tollway Route	Vehicles	Vehicle Miles			Transactions*
		PC	CV	Total	
Jane Addams Memorial	310,850	4,783,775	851,744	5,635,519	468,331
Tri-State	662,790	9,911,011	1,773,817	11,684,828	1,126,732
Reagan Memorial	250,550	4,518,451	664,079	5,182,530	417,787
Veterans Memorial	279,120	2,774,220	315,495	3,089,715	463,351
Illinois Route 390	72,360	289,250	23,676	312,926	142,229
Total	1,503,310	21,987,458	3,605,134	25,592,592	2,546,150

* Illinois Route 390 began tolling on July 5, 2016. Transactions for that route are averaged for the remainder of the year. System-wide total transactions are the sum of all 2016 transactions on all routes divided by 366. Numbers may not add due to rounding.

TABLE 1-D: SYSTEMWIDE MONTHLY FACTORS

Month	Factor
January	0.88
February	0.93
March	0.98
April	1.00
May	1.03
June	1.07
July	1.05
August	1.06
September	1.03
October	1.02
November	1.00
December	0.94

Illinois Route 390 Tollway transactions are excluded from the monthly factors calculation.



TABLE 1-E: ANNUAL TRANSACTIONS BY VEHICLE 2015-2016

Tollway Route	Passenger Vehicles		Commercial Vehicles		% CV	
	2015	2016	2015	2016	2015	2016
Jane Addams Memorial	150,452,618	151,058,487	20,223,689	20,350,580	11.8%	11.9%
Tri-State	337,911,394	353,972,385	56,620,088	58,411,610	14.4%	14.2%
Reagan Memorial	136,663,137	139,411,620	13,360,339	13,498,343	8.9%	8.8%
Veterans Memorial	152,691,865	155,530,991	13,692,270	14,055,605	8.2%	8.3%
Illinois Route 390	-	23,669,239	-	1,931,968	-	7.5%
Total	777,719,014	823,642,722	103,896,386	108,248,106	11.8%	11.6%

TABLE 1-F: I-PASS PARTICIPATION RATE* 2015-2016

Tollway Route	2015	2016	Change
Jane Addams Memorial	84.7%	85.2%	0.4%
Tri-State	84.9%	85.3%	0.4%
Reagan Memorial	88.5%	88.6%	0.1%
Veterans Memorial	91.0%	91.2%	0.2%
Illinois Route 390	-	90.2%	-
Total	86.6%	87.0%	0.4%

*Adjusted I-PASS participation rate as provided by the Illinois Tollway



TABLE 1-G: HISTORY OF TOLLWAY ADDITIONS BY MILEAGE 1959 - 2016

Year	Mainline Lane - Miles	Ramp Lane - Miles	Total Lane - Miles
1959	811	88	899
1960	812	88	900
1963	812	89	901
1966	822	92	914
1967	839	93	932
1970	839	94	933
1971	839	96	935
1972	840	97	937
1973	856	98	954
1974	1,154	109	1,263
1975	1,176	110	1,286
1976	1,200	110	1,310
1977	1,222	110	1,332
1979	1,235	110	1,345
1982	1,235	115	1,350
1983	1,235	115	1,350
1984	1,237	117	1,354
1986	1,237	118	1,355
1987	1,249	118	1,367
1988	1,249	119	1,368
1989	1,342	154	1,496
1990	1,342	156	1,498
1991	1,342	157	1,499
1992	1,354	159	1,513
1993	1,413	159	1,572
1994	1,417	164	1,581
1995	1,417	167	1,584
1996	1,427	169	1,596
1997	1,428	175	1,603
1998	1,444	179	1,623
1999	1,459	181	1,641
2000	1,467	183	1,649
2001	1,469	184	1,653
2002	1,470	184	1,654
2003	1,473	184	1,657
2004	1,477	185	1,662
2005	1,484	186	1,670
2006	1,501	186	1,687
2007	1,575	210	1,785
2008	1,599	267	1,866
2009	1,741	305	2,046
2010	1,741	305	2,046
2011	1,741	305	2,046
2012	1,744	305	2,049
2013	1,744	309	2,053
2014	1,816	316	2,132
2015	1,816	322	2,138
2016	1,919	340	2,259

Values taken from AECOM 2016 Consulting Engineer's Annual Report, Appendix I: Tollway System Expansion History



TABLE 1-H: HISTORY OF TOLLWAY ADDITIONS BY LOCATION 1959 — 2016

Year	Mainline Lane Miles	Ramp Lane Miles	Additions
1959	811	88	Original Tollway (First full year of operation)
1960	812	88	Tri-State Tollway & Jane Addams Memorial Tollway widened (3rd Lane) at O'Hare Airport
1963	812	88.5	Tri-State Tollway Willow Road Interchange (2 Ramps)
1966	822	91.5	Tri-State Tollway widened (3rd Lane) in both directions MP 0.0 to MP 5.0; I-80 Interchange added (3 Ramp-Miles)
1967	839	92.5	Jane Addams Memorial Tollway widened (3rd Lane) in both directions MP 2.5 to MP 11.0; Tri-State Tollway Lincoln Oasis ramps addition (4 Ramps)
1970	839	94	Jane Addams Memorial Tollway Arlington Heights Interchange addition
1971	839	96	Tri-State Tollway Plaza 37 ramp widening; Willow Road Interchange addition
1972	840	96.5	Tri-State Tollway widened (4th Lane) MP 39.0 to MP 40.0; Jane Addams Memorial Tollway IL Route 47 Interchange addition
1973	856	98	Tri-State Tollway widened (3rd Lane) in both directions MP 16.0 to MP 24.0; Plaza 32 ramps
1974	1154	109	Reagan Memorial Tollway Extension constructed; Tri-State Tollway widened (3rd Lane) in both directions MP 44.0 to MP 49.0; Jane Addams Memorial Tollway widened (3rd Lane) MP 11.0 to MP 17.0
1975	1176	110	Jane Addams Memorial Tollway widened (3rd Lane) in both directions MP 5.0 to MP 16.0; Barrington Road Interchange
1976	1200	110	Tri-State Tollway widened (3rd Lane) in both directions MP 49.0 to MP 53.0 and MP 62.5 to MP 70.5
1977	1222	110	Reagan Memorial Tollway widened (3rd Lane) in each direction MP 145.0 to 156.0
1979	1235	110	Tri-State Tollway widened (3rd Lane) in both directions MP 70.5 to MP 77.0
1982	1235	114.5	Reagan Memorial Tollway U.S. Route 51 Interchange & IL Route 59 Interchange ramps; Tri-State Tollway Hinsdale Oasis ramps, Plaza 37 extended & widened
1984	1237	117	Jane Addams Memorial Tollway widened (4th Lane) westbound MP 1.2 to MP 2.5 & Roselle Road Interchange ramps; Tri-State Tollway widened (4th Lane) northbound MP 41.5 to MP 42.5
1986	1237	117.5	Reagan Memorial Tollway Naperville Road Interchange (1 Ramp added)
1987	1249	118	Reagan Memorial Tollway widened (3rd Lane) in both directions MP 123.5 to MP 129.5; Jane Addams Memorial Tollway East Riverside Boulevard Interchange ramp
1988	1249	119	Reagan Memorial Tollway Orchard Road Interchange
1989	1342	154	Veterans Memorial Tollway Opened; Tri-State Tollway 95th Street Interchange (2 additional ramps) & IL Route 60 Interchange (2 additional ramps); Jane Addams Memorial Tollway East Riverside Boulevard Interchange (2 additional ramps)
1990	1342	155.5	Tri-State Tollway Lake Cook Road Interchange (2 ramps added); Jane Addams Memorial Tollway Randall Road Interchange (2 ramps added)
1991	1342	157	Tri-State Tollway 159th Street Interchange (4 ramps added)
1992	1354	158.5	Reagan Memorial Tollway IL Route 59 Interchange (4 ramps added); Jane Addams Memorial Tollway widened in both directions MP 16.6 to MP 22.6; Tri-State Tollway Plaza 32 to River Road ramp
1993	1412.5	159	Tri-State Tollway widened in both directions 95th Street to I-190; Balmoral Avenue Interchange (1 ramp added)
1994	1416.6	164.3	Tri-State Tollway 75th Street Interchange; Reagan Memorial Tollway Winfield Road Interchange; Jane Addams Memorial Tollway Beverly Road Interchange; Veterans Memorial Tollway widened (3rd Lane) MP 14.4 to MP 18.5

Values taken from AECOM 2016 Consulting Engineer's Annual Report, Appendix I: Tollway System Expansion History

(cont'd)



TABLE 1-H: HISTORY OF TOLLWAY ADDITIONS BY LOCATION 1959 — 2016

Year	Mainline Lane Miles	Ramp Lane Miles	Additions
1995	1416.6	167.3	Tri-State Tollway Lake Cook Road Exit Ramp, Southbound Buckley Road (Route 137) Interchange; Jane Addams Memorial Tollway Rockton Road Interchange
1997	1428.2	175.2	Veterans Memorial Tollway widened (3rd Lane) in both directions MP 22.6 to MP 27.9; Jane Addams Memorial Tollway Randall Road Interchange, Barrington Road & Roselle Road Interchange Plazas w/ additional westbound lane; Tri-State Tollway IL Route 137 Interchange expansion; Reagan Memorial Tollway Orchard Road Interchange
1998	1443.5	179.1	Reagan Memorial Tollway widened MP 118.7 (Plaza 61 – Aurora) to MP 123.5 (IL Route 59); Edens Spur Plaza 24 (Edens Spur); Jane Addams Memorial Tollway Fox River & Plaza 9 (Elgin) widening MP 21.75 to MP 22.0; U.S. Route 20 Bypass exit lane added; Reagan Memorial Tollway Peace Road Interchange (2 ramps added); Tri-State Tollway Willow Road Interchange (2 ramps added); Golf Road Interchange Plaza 28 lanes; Veterans Memorial Tollway 63rd Street interchange Plaza 85 widening; Ogden Avenue Interchange Plaza 81 widening
1999	1459.4	181.1	Veterans Memorial Tollway Plaza 73 (Army Trail Road); Boughton Road Interchange and Plaza expansion; Jane Addams Memorial Tollway I-290/Route 53 Interchange & Plaza 15 expansion; Tri-State Tollway widened (4th Lane) northbound from Edens Spur to Half Day Road
2000	1466.8	182.6	Reagan Memorial Tollway Plaza 61 (Aurora) I-PASS Express expansion MP 117.6 to MP 118.2; Tri-State Tollway widened (4th Lane) southbound from Half Day Road to Edens Spur Split and additional southbound exit ramp length to Lake Cook Road (MP 52.9 to MP 56.4); Tri-State Tollway Plaza 41 (163rd Street) I-PASS only lanes & increased ramp tapers to 159th Street Interchange MP 5.0 to MP 6.5
2001	1468.6	183.9	Tri-State Tollway widened from Plaza 36 (82nd Street) to 95th Street (MP 18.0 to MP 19.8); Deerfield Road northbound exit ramp added from Edens Spur and northbound entrance ramp added from Lake Cook Road (MP 52.9); Grand Avenue Interchange ramp added (MP 69.8)
2002	1469.6	183.9	Reagan Memorial Tollway Plaza 61 (Aurora) reconfigure for additional I-PASS Express Lane eastbound (MP 117.6 to MP 118.2); Tri-State Tollway Plaza 29 (Touhy) additional I-PASS Only Lane northbound (MP 41.8)
2003	1473.3	183.9	Jane Addams Memorial Tollway Plaza 19 (River Road) additional I-PASS Only Lanes (MP 0.6); Plaza 17 (Devon Avenue) additional I-PASS Only Lanes (MP 1.7); Reagan Memorial Tollway Plaza 51 (York Road) westbound convert shoulder to increase I-PASS Only Lane taper (MP 138.2)
2004	1477.2	185.1	Jane Addams Memorial Tollway Route 31 Interchange additional ramp lane at Plaza 11 (MP 24.1); Plaza 9 (Elgin) additional lane in both directions (MP 25.0); Reagan Memorial Tollway Farnsworth Avenue Interchange additional ramp lane at Plaza 59 (MP 19.3); Plaza 51 (York Road) converted shoulder eastbound on both sides of plaza (MP 138.2); Veterans Memorial Tollway widened northbound from Maple Avenue to Ogden Avenue (MP 18.3 to MP 19.5); I-55 Interchange (southbound exit to southbound I-55) additional ramp lane (MP 12.3)

Values taken from AECOM 2016 Consulting Engineer's Annual Report,
Appendix I: Tollway System Expansion History

(cont'd)



TABLE 1-H: HISTORY OF TOLLWAY ADDITIONS BY LOCATION 1959 — 2016

Year	Mainline Lane Miles	Ramp Lane Miles	Additions
2005	1484	185.5	Reagan Memorial Tollway widened in both directions from MP 123.3 to MP 126.7; Jane Addams Memorial Tollway Randall Road Interchange additional ramp lane (MP 26.6)
2006	1488.6	185.5	Tri-State Tollway widened in both directions from IL Route 394 to Halsted Street; ORT projects removed I-PASS auxiliary lanes
2007	1562.4	209.7	Veterans Memorial Tollway South Extension Added; Jane Addams Memorial Tollway IL Route 173 Interchange (MP 79.3) ramps added
2008	1586.8	209.7	Veterans Memorial Tollway widened northbound from 75th Street (MP 15.5) to Ogden Avenue (MP 19.5); Reagan Memorial widened in both directions from Washington Street (MP 126.6) to Finley Road (MP 132.0); Tri-State Tollway widened in both directions from Stearns School Road (MP 70.8) to IL Route 173 (MP 75.7)
2009	1741.2	305.5	Veteran's Memorial Tollway widened southbound from 75th Street (MP 15.5) to Ogden Avenue (MP 19.5); Reagan Memorial Tollway widened in both directions from Finley Road (MP 132.0) to IL Route 83 (MP 137.1); Tri-State Tollway widened in both directions from 163rd Street (MP 6.0) to 95th Street (MP 17.6) and from Balmoral Avenue (MP 40.0) to Stearns School Road (MP 70.8); Jane Addams Memorial Tollway widened in both directions from Newburg Road (MP 61.4) to Rockton Road (MP 75.5); Irene Road Interchange westbound exit ramp added
2010	1741.4	304.4	Reagan Memorial Tollway Farnsworth Interchange Ramp "A" widened at Plaza 59 for IPO Lane (MP 119.2); System mapping of lane miles updated to field quantity
2011	1741.4	305	Tri-State Tollway Balmoral Interchange (MP 39.8) exit ramp from northbound I-294 added
2012	1743.9	305	Reagan Memorial Tollway (I-88) Roadway Reconstruction and Widening (MP 113.4 to MP 115.8)
2013	1743.9	308.7	Jane Addams Memorial Tollway reconfigured Illinois Route 47 Interchange opened
2014	1816.1	316.3	Reconstruction of the Jane Addams Memorial Tollway (I-90); Construction of the Tri-State (I-294) & Interstate 57 Interchange
2015	1816.4	321.8	Jane Addams Memorial Tollway Irene Road ramp construction, Genoa Road Interchange reconstruction; Tri-State Tollway reconstructed Grand Avenue (IL 132) Interchange; Reagan Memorial Tollway reconstructed IL Route 59 Interchange
2016	1918.5	340.2	Widening of the Jane Addams Memorial Tollway (I-90) from east of Elgin Plaza 9 to the eastern terminus; Widening of the existing Illinois Route 390 Tollway (IL 390) from Lake Street to Rohlwing Road; Construction of the Illinois Route 390 Tollway (IL 390) & Interstate 290 Interchange

Values taken from AECOM 2016 Consulting Engineer's Annual Report,
Appendix I: Tollway System Expansion History



TABLE 1-I: SUMMARY OF TRAFFIC CHARACTERISTICS AT PLAZAS (Annual Transactions)

JANE ADDAMS MEMORIAL TOLLWAY

Plaza	Traffic			I-PASS Usage ¹			
	Total (000s)	PC%	CV%	Total (000s)	Total% ²	PC%	CV%
1	19,361	71.4%	28.6%	14,236	73.5%	69.7%	83.1%
2	2,975	92.2%	7.8%	2,589	87.0%	86.8%	88.8%
3	1,632	88.0%	12.0%	1,422	87.1%	86.7%	90.1%
4	2,077	90.1%	9.9%	1,814	87.3%	87.2%	88.9%
5	7,413	77.8%	22.2%	5,985	80.7%	78.6%	88.4%
5A	267	86.2%	13.8%	233	87.3%	87.0%	89.2%
6	6,659	92.4%	7.6%	6,220	93.4%	93.4%	92.8%
7	8,334	80.2%	19.8%	6,789	81.5%	79.6%	89.0%
8	2,685	91.3%	8.7%	2,371	88.3%	88.4%	87.6%
9	30,488	86.6%	13.4%	26,268	86.2%	85.7%	88.9%
10	2,665	96.5%	3.5%	2,355	88.4%	88.5%	84.2%
11	5,632	93.9%	6.1%	5,078	90.2%	90.1%	90.8%
12	4,119	97.0%	3.0%	3,674	89.2%	89.5%	81.0%
12A	96	97.8%	2.2%	89	92.8%	92.8%	91.8%
13	1,732	92.2%	7.8%	1,486	85.8%	85.5%	88.9%
14	3,085	93.9%	6.1%	2,801	90.8%	90.9%	89.9%
15	10,499	86.7%	13.3%	9,163	87.3%	86.8%	90.2%
16	3,999	92.0%	8.0%	3,572	89.3%	89.1%	91.7%
17	28,899	93.2%	6.8%	24,908	86.2%	86.0%	89.3%
18	6,310	91.3%	8.7%	5,774	91.5%	91.5%	91.4%
19	22,482	95.9%	4.1%	19,137	85.1%	85.0%	87.0%
Jane Addams Memorial Total	171,409	88.1%	11.9%	145,962	85.2%	84.8%	87.5%

TRI-STATE TOLLWAY

20	2,603	93.7%	6.3%	2,391	91.9%	91.9%	91.3%
21	28,682	81.1%	18.9%	23,799	83.0%	81.1%	91.0%
22	3,879	96.3%	3.7%	3,526	90.9%	91.1%	86.3%
23	4,112	96.8%	3.2%	3,735	90.8%	91.0%	84.4%
24	21,070	93.0%	7.0%	17,867	84.8%	84.7%	86.0%
26	6,525	95.8%	4.2%	5,933	90.9%	90.9%	91.6%
27	6,450	94.8%	5.2%	5,962	92.4%	92.5%	91.0%
28	6,668	96.6%	3.4%	6,078	91.1%	91.2%	90.0%
29	35,491	90.4%	9.6%	31,025	87.4%	87.0%	91.3%
30	4,112	94.2%	5.8%	3,756	91.3%	91.3%	92.2%
31	9,130	98.3%	1.7%	7,993	87.5%	87.5%	92.5%
32	6,584	98.3%	1.7%	5,652	85.9%	85.9%	86.1%
33	40,361	90.0%	10.0%	35,299	87.5%	87.0%	91.5%
34	2,405	60.3%	39.7%	2,201	91.5%	90.4%	93.3%
35	56,607	83.4%	16.6%	48,352	85.4%	84.4%	90.4%
36	30,520	83.6%	16.4%	25,945	85.0%	83.8%	90.9%
37	24,010	85.1%	14.9%	20,748	86.4%	85.6%	91.0%
38	6,069	84.6%	15.4%	5,141	84.7%	83.8%	89.5%
39	29,742	83.3%	16.7%	25,285	85.0%	83.8%	90.9%
40	2,425	86.5%	13.5%	2,047	84.4%	83.0%	93.7%
41	39,189	78.3%	21.7%	32,414	82.7%	80.4%	91.1%
42	12,249	86.5%	13.5%	10,943	89.3%	88.9%	92.4%
43	13,092	75.8%	24.2%	9,951	76.0%	75.0%	79.3%
45	12,307	74.8%	25.2%	9,421	76.6%	75.2%	80.7%
47	8,103	91.5%	8.5%	6,140	75.8%	74.0%	95.3%
Tri-State Total	412,384	85.8%	14.2%	351,603	85.3%	84.5%	89.7%

¹ Adjusted I-PASS percentage provided by Illinois Tollway

² Percent of total traffic

(cont'd)



TABLE 1-I: SUMMARY OF TRAFFIC CHARACTERISTICS AT PLAZAS (Annual Transactions)

REAGAN MEMORIAL TOLLWAY

Plaza	Traffic			I-PASS Usage ¹			
	Total (000s)	PC%	CV%	Total (000s)	Total% ²	PC%	CV%
51	33,525	93.4%	6.6%	29,600	88.3%	88.1%	91.4%
52	32,420	92.9%	7.1%	28,768	88.7%	88.5%	91.4%
53	3,194	98.0%	2.0%	2,964	92.8%	92.8%	91.6%
54	3,048	97.1%	2.9%	2,757	90.5%	90.5%	90.9%
55	1,639	98.7%	1.3%	1,487	90.7%	90.7%	92.1%
56	5,527	98.5%	1.5%	5,108	92.4%	92.5%	89.0%
57	4,078	97.8%	2.2%	3,750	92.0%	92.1%	87.8%
58	2,808	97.7%	2.3%	2,601	92.6%	92.7%	88.7%
59	9,708	92.2%	7.8%	8,448	87.0%	86.9%	88.4%
60	4,162	93.9%	6.1%	3,885	93.3%	93.4%	92.2%
61	31,121	89.2%	10.8%	27,792	89.3%	89.0%	91.7%
63	1,424	93.1%	6.9%	1,254	88.1%	87.8%	91.8%
64	1,618	88.1%	11.9%	1,456	90.0%	89.5%	94.1%
65	3,512	89.4%	10.6%	3,156	89.8%	89.3%	94.4%
66	7,909	73.6%	26.4%	6,669	84.3%	81.7%	91.6%
67	1,988	95.7%	4.3%	1,718	86.4%	86.3%	90.0%
69	5,228	74.3%	25.7%	4,117	78.7%	75.1%	89.3%
Reagan Memorial Total	152,910	91.2%	8.8%	135,532	88.6%	88.4%	91.2%

VETERANS MEMORIAL TOLLWAY

73	42,224	92.0%	8.0%	38,385	90.9%	90.9%	91.1%
75	10,930	87.3%	12.7%	9,944	91.0%	90.8%	91.9%
77	6,039	97.3%	2.7%	5,590	92.6%	92.6%	89.7%
79	6,417	97.4%	2.6%	5,896	91.9%	91.9%	89.9%
81	1,753	95.6%	4.4%	1,614	92.0%	92.3%	85.5%
83	4,515	96.2%	3.8%	4,211	93.3%	93.5%	86.4%
85	6,251	97.6%	2.4%	5,868	93.9%	94.1%	85.3%
87	6,240	97.0%	3.0%	5,818	93.2%	93.4%	89.5%
89	46,242	89.7%	10.3%	41,800	90.4%	90.3%	91.6%
90	4,773	96.6%	3.4%	4,242	88.9%	89.2%	80.7%
93	2,568	92.5%	7.5%	2,411	93.9%	93.9%	93.9%
95	3,759	94.6%	5.4%	3,467	92.2%	92.3%	91.4%
97	4,980	96.5%	3.5%	4,639	93.2%	93.2%	92.2%
99	21,095	86.7%	13.3%	19,166	90.9%	90.6%	92.4%
101	1,800	95.0%	5.0%	1,580	87.8%	87.7%	89.0%
Veterans Memorial Total	169,587	91.7%	8.3%	154,632	91.2%	91.2%	91.3%

ILLINOIS ROUTE 390 TOLLWAY

326	10,406	92.4%	7.6%	9,407	90.4%	90.4%	90.4%
328	9,910	92.5%	7.5%	8,957	90.4%	90.3%	91.1%
330	5,285	92.4%	7.6%	4,730	89.5%	89.5%	89.3%
Illinois Route 390 Total	25,601	92.5%	7.5%	23,094	90.2%	90.2%	89.7%
Tollway Total	931,891	88.4%	11.6%	810,823	87.0%	86.7%	89.7%

¹ Adjusted I-PASS percentage provided by Illinois Tollway

² Percent of total traffic



FIGURE 1-A: THE ILLINOIS TOLLWAY SYSTEM 2016



FIGURE 1-B: AVERAGE ANNUAL DAILY TRAFFIC 2016



FIGURE 1-C: AVERAGE ANNUAL DAILY TRAFFIC 1960

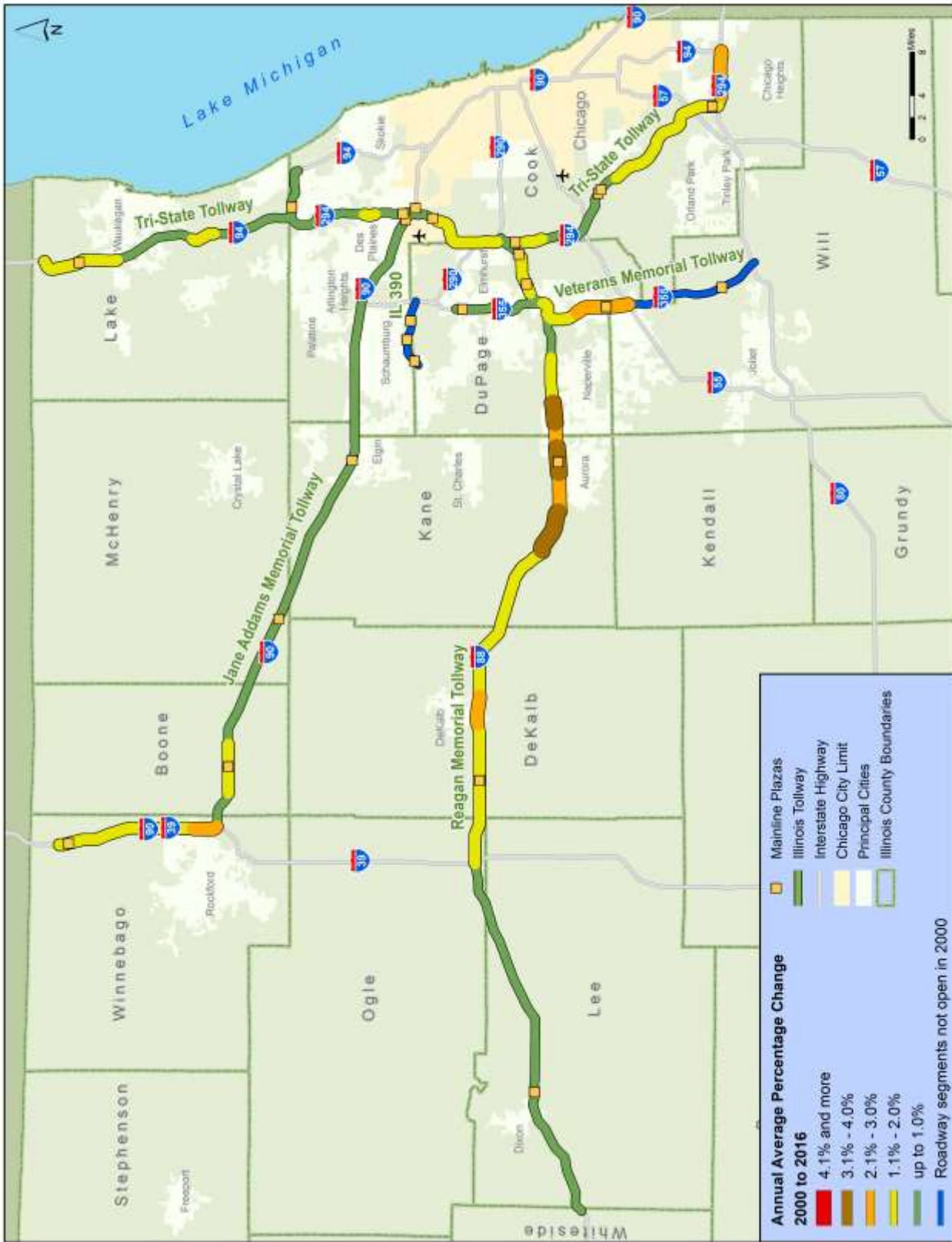

FIGURE 1-D: ANNUAL AVERAGE PERCENTAGE CHANGE IN DAILY TRAFFIC VOLUMES 2000-2016

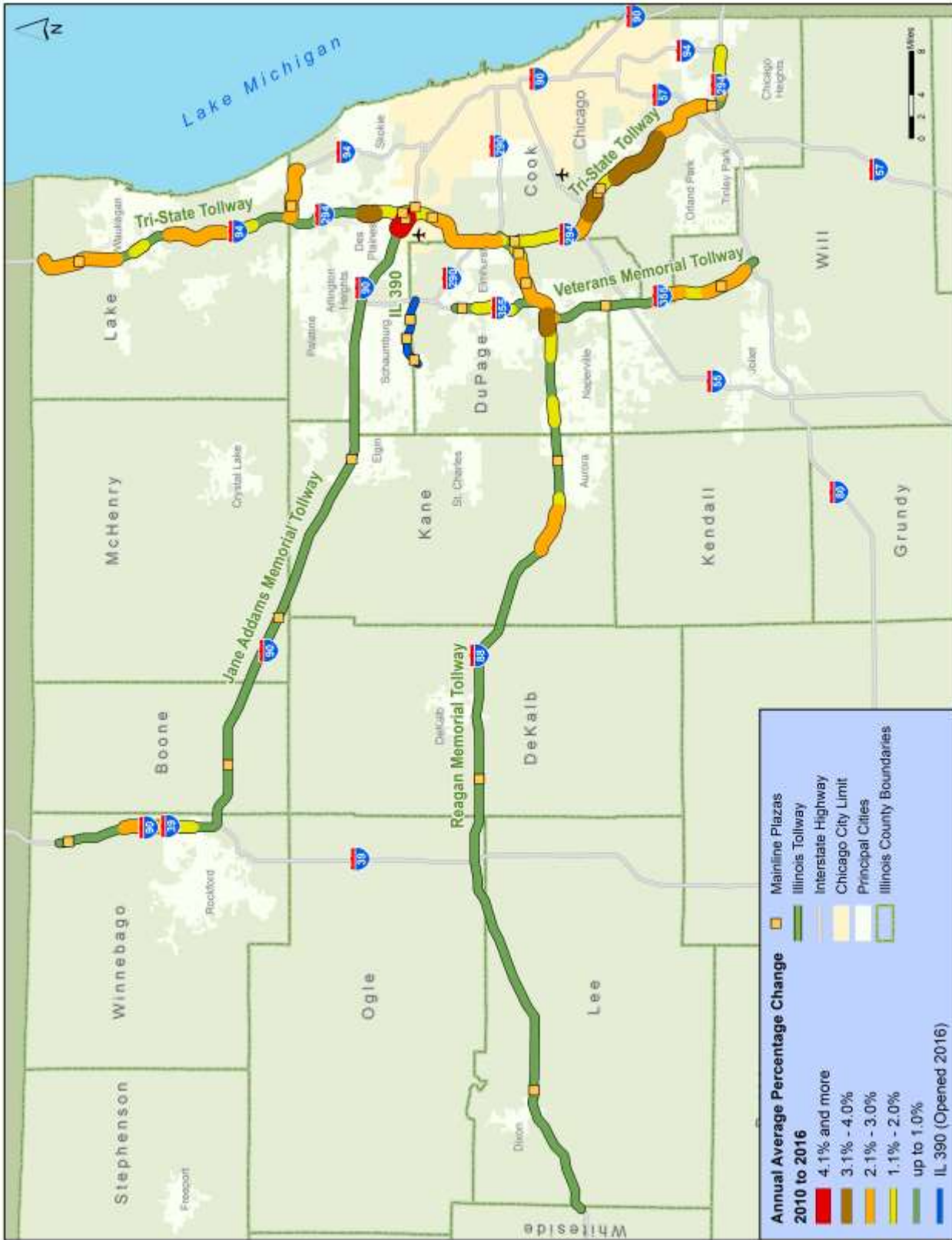

FIGURE 1-E: ANNUAL AVERAGE PERCENTAGE CHANGE IN DAILY TRAFFIC VOLUMES 2010-2016

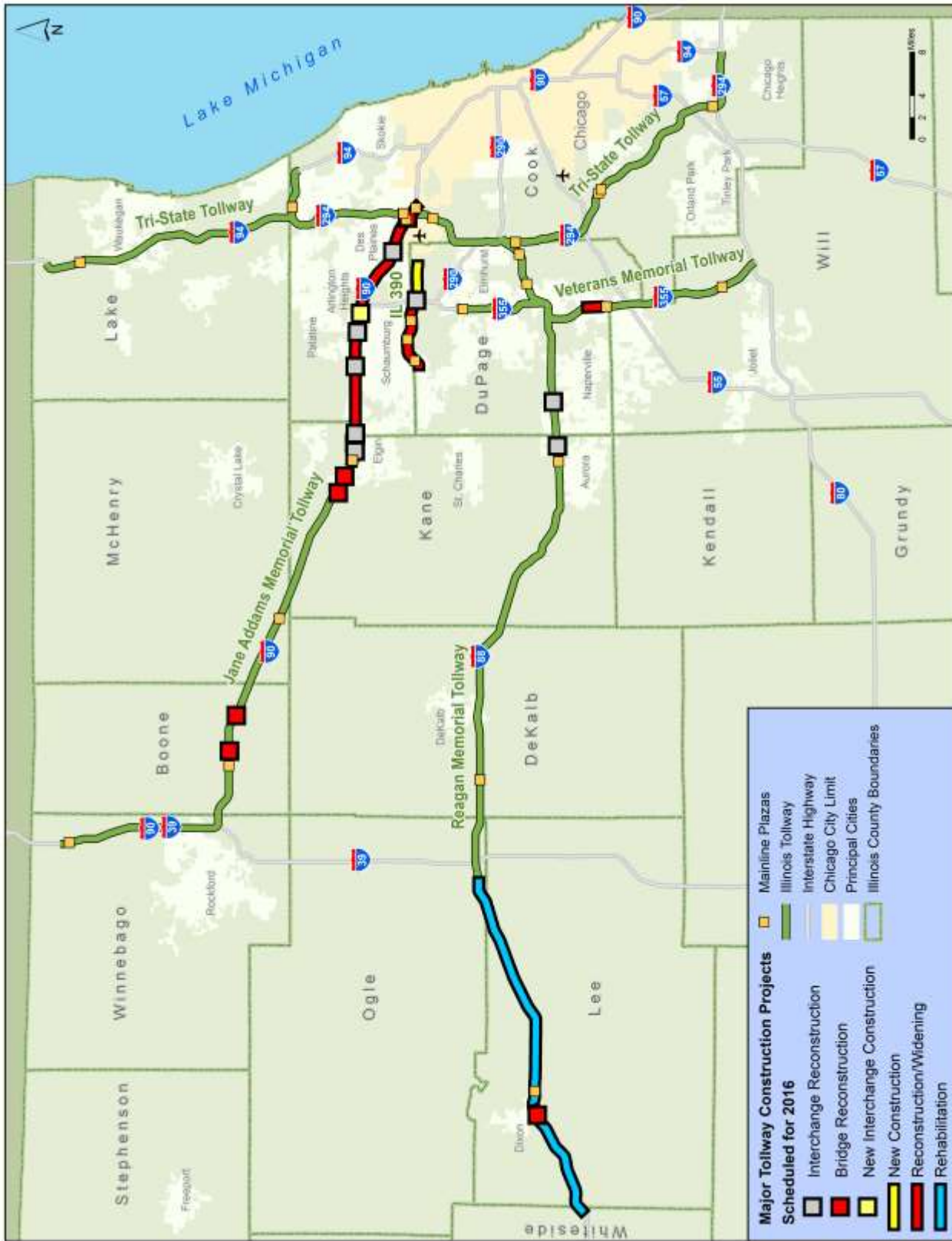

FIGURE 1-F: MAJOR TOLLWAY CONSTRUCTION PROJECTS DURING 2016

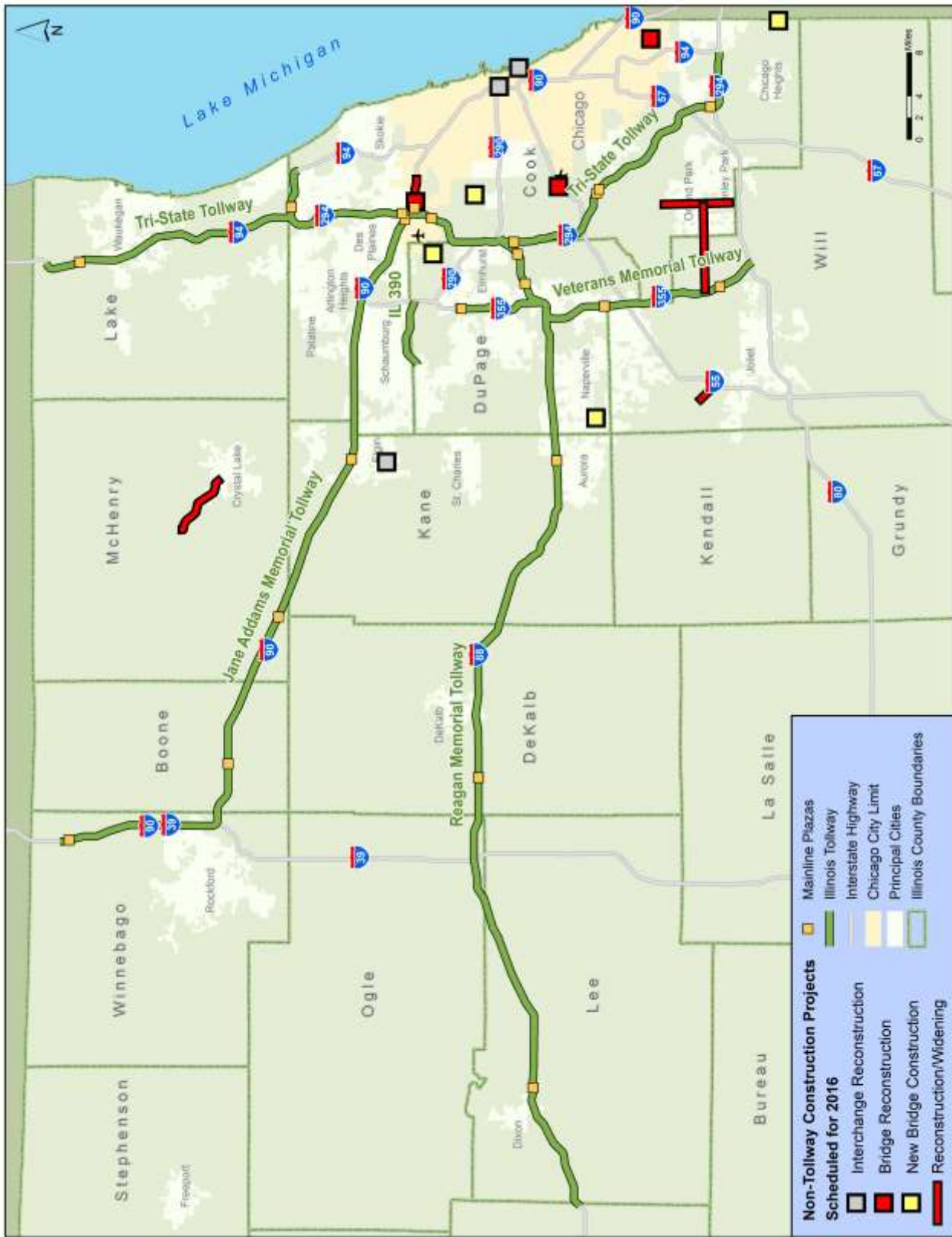

FIGURE 1-G: MAJOR OFF-TOLLWAY CONSTRUCTION PROJECTS DURING 2016



Section 2

Jane Addams Memorial Tollway



SECTION 2

Jane Addams Memorial Tollway

TABULATIONS TABLE

	PAGE
2-A Average Daily Traffic Volumes Between Interchanges 1980 – 2016 (Westbound)	2-4
2-B Average Daily Traffic Volumes Between Interchanges 1980 – 2016 (Eastbound)	2-5
2-C General Statistics for Mainline Plazas	2-6
2-D Indexed Monthly Variation by Mainline Plaza	2-8
2-E Indexed Daily Variation by Mainline Plaza	2-8
2-F Annual Total Transactions by Toll Plaza	2-9
2-G Average Daily Traffic Data	2-10

ILLUSTRATIONS FIGURE

	PAGE
2-A Mainline Plaza Highest Hourly Volume Plaza 1 EB	2-11
2-B Mainline Plaza Highest Hourly Volume Plaza 1 WB	2-11
2-C Mainline Plaza Highest Hourly Volume Plaza 5 WB	2-11
2-D Mainline Plaza Highest Hourly Volume Plaza 7 EB	2-11
2-E Mainline Plaza Highest Hourly Volume Plaza 9 EB	2-12
2-F Mainline Plaza Highest Hourly Volume Plaza 9 WB	2-12
2-G Mainline Plaza Highest Hourly Volume Plaza 17 WB	2-12
2-H Mainline Plaza Highest Hourly Volume Plaza 19 EB	2-12
2-I Average Daily Traffic Trends Plaza 1 South Beloit	2-13
2-J Average Daily Traffic Trends Plaza 2 East Riverside Boulevard	2-13
2-K Average Daily Traffic Trends Plaza 3 Genoa Road	2-13
2-L Average Daily Traffic Trends Plaza 4 Illinois Route 173	2-14
2-M Average Daily Traffic Trends Plaza 5 Belvidere	2-14
2-N Average Daily Traffic Trends Plaza 5A Irene Road	2-14
2-O Average Daily Traffic Trends Plaza 6 Illinois Route 47	2-15
2-P Average Daily Traffic Trends Plaza 7 Marengo-Hampshire	2-15
2-Q Average Daily Traffic Trends Plaza 8 Randall Road	2-15
2-R Average Daily Traffic Trends Plaza 9 Elgin	2-16
2-S Average Daily Traffic Trends Plaza 10 Barrington Road	2-16
2-T Average Daily Traffic Trends Plaza 11 Illinois 31	2-16
2-U Average Daily Traffic Trends Plaza 12 Roselle Road	2-17



SECTION 2

Jane Addams Memorial Tollway

ILLUSTRATIONS (CONTINUED)

FIGURE	PAGE
2-V Average Daily Traffic Trends Plaza 13 Illinois 25	2-17
2-W Average Daily Traffic Trends Plaza 14 Illinois Route 59	2-17
2-X Average Daily Traffic Trends Plaza 15 I-290, Illinois Route 53	2-18
2-Y Average Daily Traffic Trends Plaza 16 Beverly Road	2-18
2-Z Average Daily Traffic Trends Plaza 17 Devon Avenue	2-18
2-AA Average Daily Traffic Trends Plaza 18 Arlington Heights Road	2-19
2-AB Average Daily Traffic Trends Plaza 19 River Road	2-19
2-AC Average Weekday Speed Distributions, Eastern Section—Eastbound	2-20
2-AD Average Weekday Speed Distributions, Eastern Section—Westbound	2-20
2-AE Average Weekday Speed Distributions, Western Section—Eastbound	2-20
2-AF Average Weekday Speed Distributions, Western Section—Westbound	2-20
2-AG Roadway Performance Measures, Eastern Section	2-21
2-AH Roadway Performance Measures, Western Section	2-22
2-AI Average Speed Contours, MP 55.0 to 78.5	2-23
2-AJ Average Speed Contours, MP 32.0 to 54.5	2-24



This Page Is Intentionally Left Blank



TABLE 2-A: AVERAGE DAILY TRAFFIC VOLUMES BETWEEN INTERCHANGES 1980-2016 (WESTBOUND)

Location	Mile Post	Miles Btwn. Int.	ADT 1980	Average Annual Percent Change	ADT 1990	Average Annual Percent Change	ADT 2000	Average Annual Percent Change	ADT 2010	Average Annual Percent Change	ADT 2016
Kennedy Expressway	78.6										
		0.8	39,270	4.0	58,040	1.4	66,420	-0.5	62,870	-0.8	58,510
Tri-State Interchange	77.8										
		0.5	51,310	3.7	73,590	1.5	85,520	-0.2	83,420	-1.3	76,020
Devon Avenue	77.3										
Toll Plaza 17	77.3	1.2	56,160	3.7	80,790	1.4	93,190	-0.4	89,150	-1.8	78,960
Lee Street	76.1										
		1.7	52,730	3.5	74,740	1.6	87,610	-0.5	83,390	-1.9	73,270
Des Plaines Oasis	74.4										
		0.9	52,730	3.5	74,740	1.6	87,610	-0.5	83,390	-1.9	73,270
Elmhurst Road	73.5										
		2.8	40,790	3.8	59,510	1.8	70,910	-0.1	70,530	-2.2	60,570
Arlington Heights Road (PL18)	70.7										
		2.5	34,440	3.8	50,010	3.9	73,120	-0.2	71,440	-2.5	59,170
Illinois Route 53/I-290	68.2										
		0.9	29,360	5.9	51,970	3.2	71,530	0.0	71,440	-2.5	68,940
Meacham Road (PL12A)	67.3										
		1.8	29,360	5.9	51,970	3.2	71,530	1.2	80,270	-2.0	68,940
Roselle Road (PL12)	65.5										
		3.3	29,360	3.9	43,100	3.6	61,490	1.2	69,090	-2.1	59,090
Barrington Road (PL10)	62.2										
		2.5	17,070	4.5	26,580	6.4	49,640	1.8	59,410	-2.1	51,810
Illinois Route 59 (PL14)	59.7										
		1.6	18,470	4.9	29,780	4.9	48,160	2.4	61,340	-2.3	53,250
Beverly Road (PL16)	58.1										
		1.8	18,470	4.9	29,780	3.8	43,120	2.7	56,220	-2.4	49,090
Illinois Route 25 (PL13)	56.3										
		1.7	16,330	4.9	26,350	4.7	41,520	2.7	54,370	-2.1	48,120
Illinois Route 31 (PL11)	54.6										
Toll Plaza 9	53.8	2.5	11,340	4.2	17,090	6.6	32,270	3.5	45,660	-1.7	41,730
Randall Road (PL8)	52.1										
		5.7	11,340	2.9	15,020	5.6	25,780	2.4	32,800	-1.3	30,860
Illinois Route 47	46.4										
		4.5	10,130	2.0	12,380	5.4	20,870	1.8	25,040	-0.8	24,120
Marengo Road (U.S. Route 20)	41.9										
		16.6	9,340	2.5	12,000	4.9	19,320	1.9	23,390	-0.9	22,850
Genoa Road (PL3)	25.3										
		1.1	8,490	2.5	10,860	4.1	16,300	1.8	19,420	-0.2	20,260
Belvidere Oasis	24.2										
Toll Plaza 5	23.3	3.4	8,490	2.5	10,860	4.1	16,300	1.8	19,420	-0.2	20,260
Irene Road (PL 5A)	20.8										
		3.4	8,490	2.5	10,860	4.1	16,300	1.7	19,200	-0.2	20,460
I-39/U.S. Route 20 (Cherry Valley)	17.4										
		2.2	9,160	4.6	14,330	3.9	21,010	3.1	28,380	1.6	32,460
U.S. Business 20	15.2										
		2.9	8,270	5.2	13,750	4.8	22,060	1.7	26,060	1.7	29,940
E. Riverside Boulevard (PL2)	12.3										
		3.4	8,270	4.8	13,180	4.7	20,840	1.5	24,300	2.0	28,300
Illinois Route 173 (PL4)	8.9										
Toll Plaza 1	3.5	6.2	8,270	4.8	13,180	4.7	20,840	0.9	22,800	1.8	26,170
West Terminus	2.7										



TABLE 2-B: AVERAGE DAILY TRAFFIC VOLUMES BETWEEN INTERCHANGES 1980-2016 (EASTBOUND)

Location	Mile Post	Miles Btwn. Int.	ADT 1980	Average Annual Percent Change	ADT 1990	Average Annual Percent Change	ADT 2000	Average Annual Percent Change	ADT 2010	Average Annual Percent Change	ADT 2016
Kennedy Expressway	78.6										
Toll Plaza 19	78.5	0.8	48,260	3.3	67,020	1.3	76,300	-0.9	69,600	-2.1	61,420
Tri-State Interchange	77.8										
		0.5	55,550	3.4	77,830	2.5	99,340	-1.7	83,980	-1.4	77,110
Devon Avenue	77.3										
	77.3	1.2	55,550	3.4	77,830	2.5	99,340	-1.7	83,980	-1.4	77,110
Lee Street	76.1										
		1.7	52,110	3.3	71,920	2.4	91,250	-1.6	77,640	-1.4	71,290
Des Plaines Oasis	74.4										
		0.9	52,110	3.3	71,920	2.4	91,250	-1.6	77,640	-1.4	71,290
Elmhurst Road	73.5										
		2.8	40,200	3.6	57,210	2.3	72,090	-0.5	68,390	-1.4	62,810
Arlington Heights Road (PL18)	70.7										
		2.5	33,800	3.6	48,150	4.3	73,360	-0.4	70,680	-1.8	63,300
Illinois Route 53/I-290 (PL 15)	68.2										
		2.7	29,110	5.8	50,930	4.2	77,040	0.7	82,430	-2.5	70,880
Roselle Road	65.5										
		3.3	29,110	3.9	42,540	4.8	68,280	0.4	70,850	-2.4	61,130
Barrington Road	62.2										
		2.5	16,770	4.6	26,250	7.5	54,030	0.9	59,150	-2.1	52,010
Illinois Route 59 (PL 14)	59.7										
		1.6	18,090	5.0	29,480	5.5	50,150	1.9	60,830	-2.3	53,060
Beverly Road	58.1										
		1.8	18,090	5.0	29,480	4.3	44,840	2.1	55,370	-2.3	48,050
Illinois Route 25 (PL 13)	56.3										
		1.7	15,860	5.1	26,180	5.1	43,030	2.3	54,220	-2.0	47,970
Illinois Route 31 (PL 11)	54.6										
Toll Plaza 9	53.8	2.5	11,660	4.1	17,360	6.6	32,790	3.3	45,350	-1.4	41,560
Randall Road (PL8)	52.1										
		5.7	11,660	2.7	15,290	5.5	26,180	2.5	33,500	-1.0	31,620
Illinois Route 47	46.4										
		4.5	10,360	2.0	12,620	5.1	20,770	2.5	26,520	-0.9	25,090
Marengo Road (U.S. Route 20)	41.9										
Toll Plaza 7		16.6	9,290	2.6	12,000	4.7	19,010	2.0	23,220	-0.3	22,770
Genoa Road (PL3)	25.3										
		1.1	8,720	2.3	10,990	4.1	16,430	2.2	20,470	0.0	20,450
Belvidere Oasis	24.2										
		3.4	8,720	2.3	10,990	4.1	16,430	2.2	20,470	0.0	20,450
Irene Road (PL 5A)	20.8										
		3.4	8,720	2.3	10,990	4.1	16,430	2.2	20,470	0.2	20,670
I-39/U.S. Route 20 (Cherry Valley)	17.4										
		2.2	9,490	4.6	14,920	3.5	20,960	2.9	27,820	2.6	32,360
U.S. Business 20	15.2										
		2.9	8,430	5.2	14,000	4.3	21,370	2.2	26,690	2.3	30,570
E. Riverside Boulevard (PL2)	12.3										
		3.4	8,430	4.8	13,450	4.1	20,100	2.1	24,680	2.6	28,760
Illinois Route 173 (PL4)	8.9										
Toll Plaza 1	3.5	6.2	8,430	4.8	13,450	4.1	20,100	1.5	23,420	2.2	26,720
West Terminus	2.7										



**TABLE 2-C: GENERAL STATISTICS FOR MAINLINE PLAZAS
(Vehicles/Hour)**

Mainline Plaza	Dir.	30th HV	Period	Mean	Med.	Max.	Min.	Std. Dev.	85th %
1 South Beloit	EB	3,128	AM Peak	1,370	1,289	1,764	857	266	1,655
			PM Peak	1,868	1,861	2,663	1,358	220	2,082
			OFF Peak	974	892	2,846	115	578	1,603
			Weekend	1,147	1,068	3,380	91	770	2,037
			Holidays	1,223	1,039	3,404	82	932	2,392
	WB	3,001	AM Peak	1,175	1,139	1,593	755	218	1,423
			PM Peak	1,838	1,819	2,448	1,361	219	2,068
			OFF Peak	958	983	2,425	131	543	1,561
			Weekend	1,140	1,092	3,527	79	747	1,988
			Holidays	1,155	1,024	3,541	61	850	2,088
5 Belvidere	WB	2,273	AM Peak	904	883	1,218	521	167	1,106
			PM Peak	1,293	1,279	1,759	827	157	1,464
			OFF Peak	722	754	1,698	90	402	1,152
			Weekend	916	912	2,911	65	561	1,537
			Holidays	929	899	2,819	62	640	1,610
7 Marengo-Hampshire	EB	2,710	AM Peak	1,346	1,354	1,514	987	93	1,439
			PM Peak	1,293	1,288	1,797	936	165	1,464
			OFF Peak	809	919	2,056	86	435	1,247
			Weekend	1,011	1,041	2,873	83	636	1,681
			Holidays	1,076	1,064	2,983	99	776	1,852
9 Elgin	EB	3,960	AM Peak	3,658	3,690	4,144	2,669	267	3,888
			PM Peak	2,264	2,256	2,818	1,674	181	2,446
			OFF Peak	1,504	1,571	3,395	141	903	2,427
			Weekend	1,713	1,846	3,865	144	1,013	2,800
			Holidays	1,723	1,704	3,615	184	1,091	3,034
	WB	4,360	AM Peak	1,815	1,789	2,214	1,327	233	2,062
			PM Peak	3,944	3,996	4,505	2,727	294	4,179
			OFF Peak	1,532	1,697	3,991	142	941	2,447
			Weekend	1,722	1,783	4,691	150	1,033	2,738
			Holidays	1,649	1,629	4,490	123	1,073	2,695

(cont'd)



**TABLE 2-C: GENERAL STATISTICS FOR MAINLINE PLAZAS
(Vehicles/Hour)**

Mainline Plaza	Dir.	30th HV	Period	Mean	Med.	Max.	Min.	Std. Dev.	85th %
17 Devon Avenue	WB	5,961	AM Peak	5,242	5,224	6,119	3,808	491	5,776
			PM Peak	5,488	5,531	6,097	4,559	341	5,796
			OFF Peak	3,056	3,431	6,087	279	1,674	4,856
			Weekend	3,129	3,333	6,080	406	1,540	4,760
			Holidays	2,787	2,856	5,467	396	1,504	4,432
<hr/>									
19 River Road	EB	4,362	AM Peak	3,194	3,227	3,797	2,454	277	3,484
			PM Peak	3,164	3,182	4,012	2,339	363	3,561
			OFF Peak	2,416	2,880	4,582	208	1,288	3,681
			Weekend	2,594	3,127	4,506	227	1,278	3,804
			Holidays	2,401	2,829	4,690	281	1,287	3,646

AM Peak = Weekday 6:00 AM To 8:00 AM Except Fridays
 PM Peak = Weekday 4:00 PM To 6:00 PM Except Fridays
 OFF Peak = Weekdays Except Fridays and AM and PM Peak Periods
 Weekend = Fridays, Saturdays, and Sundays
 Holidays = See Page 1-6 for a list of Holidays.



TABLE 2-D: INDEXED MONTHLY VARIATION BY MAINLINE PLAZA

Month	South Beloit	Belvidere	Marengo	Elgin	Devon Avenue	River Road
January	0.80	0.79	0.81	0.87	0.91	0.96
February	0.84	0.83	0.85	0.91	0.96	1.00
March	0.93	0.92	0.92	0.96	1.00	1.01
April	0.95	0.95	0.95	0.97	1.01	1.01
May	1.03	1.05	1.03	1.02	1.03	1.01
June	1.14	1.11	1.09	1.06	1.06	1.02
July	1.23	1.21	1.19	1.09	1.03	1.05
August	1.15	1.15	1.16	1.09	1.04	1.05
September	1.06	1.07	1.07	1.04	1.02	1.01
October	1.02	1.02	1.04	1.02	1.01	0.98
November	0.97	0.98	0.99	1.00	0.99	0.96
December	0.88	0.90	0.90	0.95	0.94	0.95

TABLE 2-E: INDEXED DAILY VARIATION BY MAINLINE PLAZA

Month	Day	South Beloit	Belvidere	Marengo	Elgin	Devon Avenue	River Road
August	Monday	1.14	1.16	1.13	1.09	1.05	1.05
	Tuesday	1.11	1.12	1.14	1.07	1.04	1.05
	Wednesday	1.11	1.14	1.13	1.07	1.04	1.06
	Thursday	1.13	1.16	1.14	1.08	1.02	1.05
	Friday	1.15	1.18	1.13	1.08	1.02	1.05
	Saturday	1.18	1.16	1.18	1.10	1.02	1.04
	Sunday	1.27	1.20	1.31	1.18	1.08	1.07
December	Monday	0.93	0.99	0.92	0.95	0.92	0.94
	Tuesday	1.00	1.02	1.01	1.02	0.98	0.98
	Wednesday	0.99	1.02	1.02	1.03	0.97	0.98
	Thursday	0.97	0.96	0.99	1.01	0.97	0.98
	Friday	0.87	0.85	0.95	0.96	0.96	0.96
	Saturday	0.76	0.77	0.81	0.88	0.89	0.89
	Sunday	0.62	0.71	0.63	0.77	0.81	0.84

Table 2-E includes Monthly Variation



TABLE 2-F: ANNUAL TOTAL TRANSACTIONS BY TOLL PLAZA

Plaza	Plaza Code*	2015	2016	Percentage Change
1 South Beloit	M	18,757,580	19,360,839	3.2%
2 E. Riverside Boulevard	R	2,872,464	2,975,139	3.6%
3 Genoa Road**	R	488,984	1,631,657	233.7%
4 Illinois Route 173	R	1,941,051	2,077,184	7.0%
5 Belvidere	M1	6,981,322	7,413,271	6.2%
5A Irene Road***	R		266,894	
6 Illinois Route 47	E	6,265,610	6,659,366	6.3%
7 Marengo	M1	7,990,153	8,333,515	4.3%
8 Randall Road	R	2,553,250	2,685,064	5.2%
9 Elgin	M	30,122,939	30,488,142	1.2%
10 Barrington Road	R	3,103,301	2,664,881	-14.1%
11 Illinois Route 25	R	6,078,903	5,632,339	-7.3%
12 Roselle Road	R	3,757,738	4,119,042	9.6%
12A Meacham Road****	E		96,063	
13 Illinois Route 25	R	1,821,019	1,732,169	-4.9%
14 Illinois Route 59	R	3,082,690	3,085,015	0.1%
15 Illinois Route 53	R1	11,473,611	10,499,182	-8.5%
16 Beverly Road	R1	4,334,416	3,998,691	-7.7%
17 Devon Avenue	M1	29,262,808	28,898,863	-1.2%
18 Arlington Heights Road	R	6,722,443	6,309,872	-6.1%
19 River Road	M1	23,066,025	22,481,879	-2.5%
Jane Addams Memorial Total		170,676,307	171,409,067	0.4%

* M=Mainline / R=Ramp / A=Attended Ramp Plaza / E=Electronic Toll Collection Only Ramp
1=Toll Collected in One Direction Only

** Plaza opened September 2015.

*** Plaza opened January 2016.

**** Plaza opened November 2016.



TABLE 2-G: AVERAGE DAILY TRAFFIC DATA

Year	Average Daily Total			Average Trip
	Vehicles	Vehicle Miles	Transactions	Length (Miles)
1959	10,937	513,839	16,852	46.98
1960	21,417	720,403	29,637	33.64
1961	30,379	893,740	41,601	29.42
1962	35,337	978,261	48,297	27.68
1963	36,384	1,060,625	52,810	29.15
1964	38,704	1,130,304	55,528	29.20
1965	44,034	1,239,411	62,735	28.15
1966	49,418	1,348,751	68,336	27.29
1967	53,402	1,397,288	73,035	26.17
1968	59,443	1,535,620	81,811	25.83
1969	66,752	1,637,427	118,986	24.53
1970	75,218	1,757,108	138,024	23.36
1971	81,517	1,867,136	146,198	22.90
1972	87,416	1,929,076	156,403	22.07
1973	102,262	2,070,220	175,930	20.24
1974	101,814	2,001,520	171,108	19.66
1975	110,185	2,141,250	184,352	19.43
1976	118,923	2,301,465	199,710	19.35
1977	126,388	2,435,431	212,020	19.27
1978	134,830	2,502,453	220,878	18.56
1979	139,786	2,606,029	228,180	18.64
1980	140,928	2,536,515	227,729	18.00
1981	143,284	2,619,176	230,868	18.28
1982	146,090	2,634,806	234,034	18.04
1983	152,561	2,770,933	247,674	18.16
1984	144,728	2,666,506	238,152	18.42
1985	164,771	2,861,454	257,366	17.37
1986	175,655	3,134,635	281,112	17.85
1987	191,936	3,392,046	307,469	17.67
1988	205,510	3,558,352	329,391	17.31
1989	213,965	3,643,665	336,575	17.03
1990	225,655	3,669,541	347,884	16.26
1991	222,370	3,673,993	365,120	16.52
1992	234,074	4,081,095	375,921	17.44
1993	253,304	4,279,655	389,127	16.90
1994	260,359	4,533,228	412,288	17.41
1995	269,680	4,774,725	432,373	17.71
1996	275,020	4,912,102	439,095	17.86
1997	282,900	5,105,618	454,622	18.05
1998	284,860	5,125,064	480,098	17.99
1999	294,050	5,567,182	512,810	18.93
2000	294,850	5,402,466	507,784	18.32
2001	309,100	5,828,988	541,479	18.86
2002	296,870	5,773,234	532,658	19.45
2003	304,510	5,857,387	541,345	19.24
2004	323,450	6,158,090	556,501	19.04
2005	312,300	6,002,609	530,257	19.22
2006	312,990	5,918,699	478,556	18.91
2007	318,420	6,120,967	492,225	19.22
2008	313,550	5,853,800	479,141	18.67
2009	308,050	5,744,595	473,015	18.65
2010	335,170	5,994,090	484,642	17.88
2011	317,070	5,813,945	470,237	18.34
2012	308,770	5,659,154	456,180	18.33
2013	309,780	5,376,980	448,008	17.36
2014	307,320	5,327,905	455,312	17.34
2015	314,120	5,598,660	467,606	17.82
2016	310,850	5,635,519	468,331	18.13



FIGURE 2-A

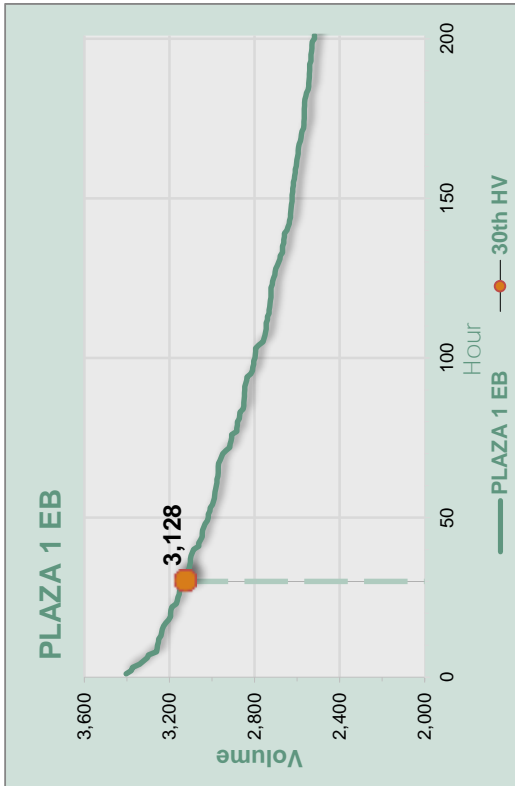

FIGURE 2-B

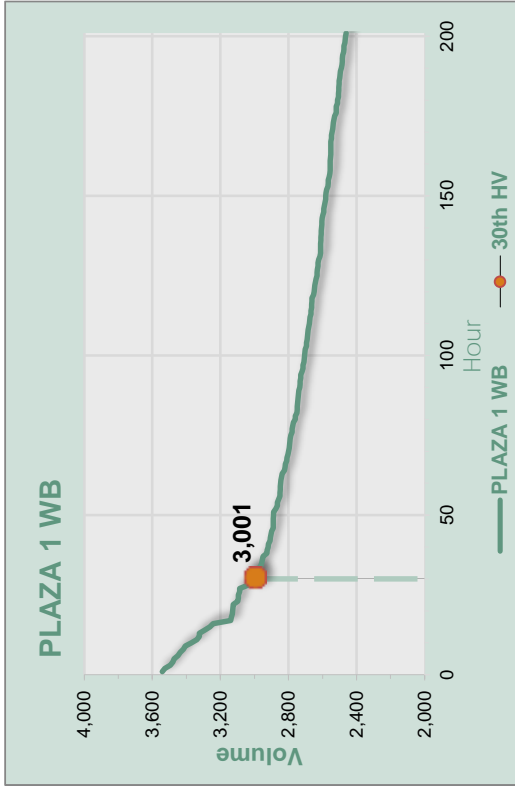
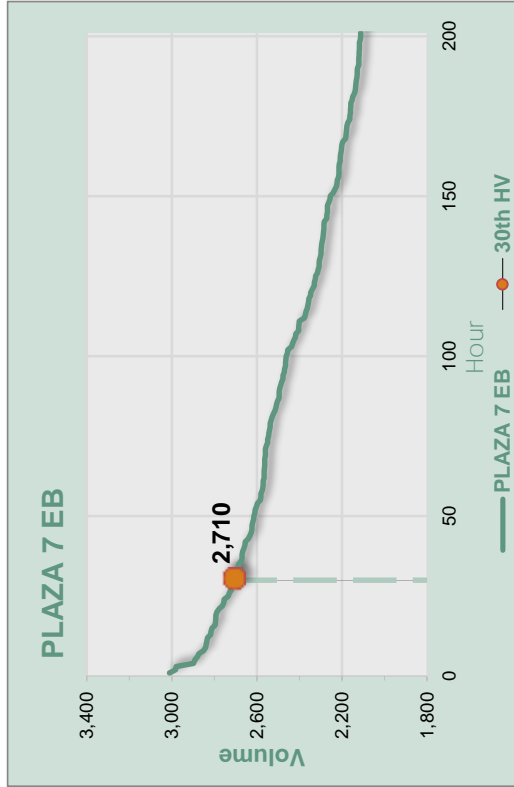

FIGURE 2-C



FIGURE 2-D



MAINLINE PLAZA HIGHEST HOURLY VOLUME



FIGURE 2-F



FIGURE 2-H

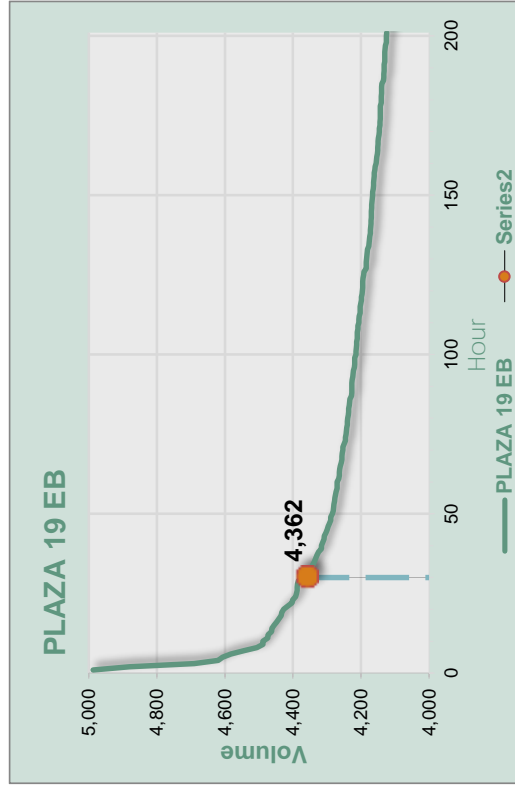

FIGURE 2-E

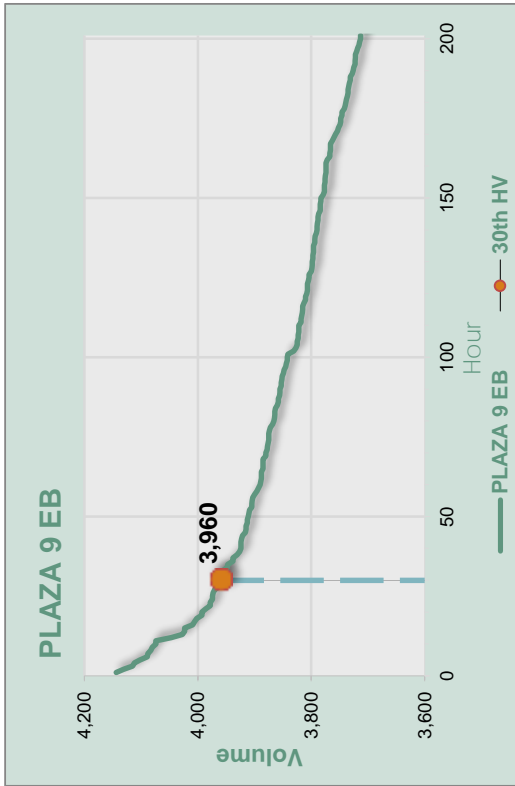

FIGURE 2-G



MAINLINE PLAZA HIGHEST HOURLY VOLUME



FIGURE 2-I

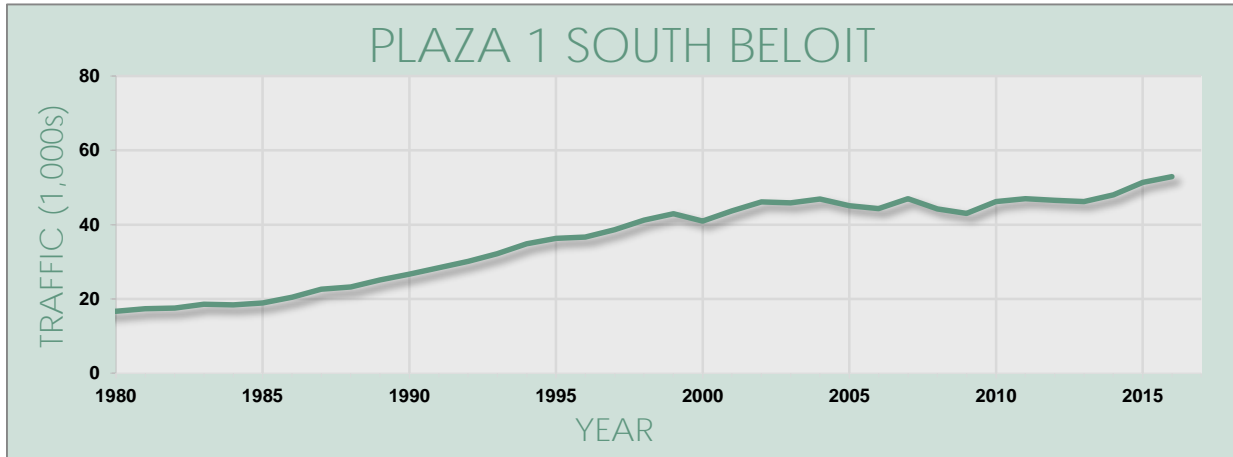

FIGURE 2-J

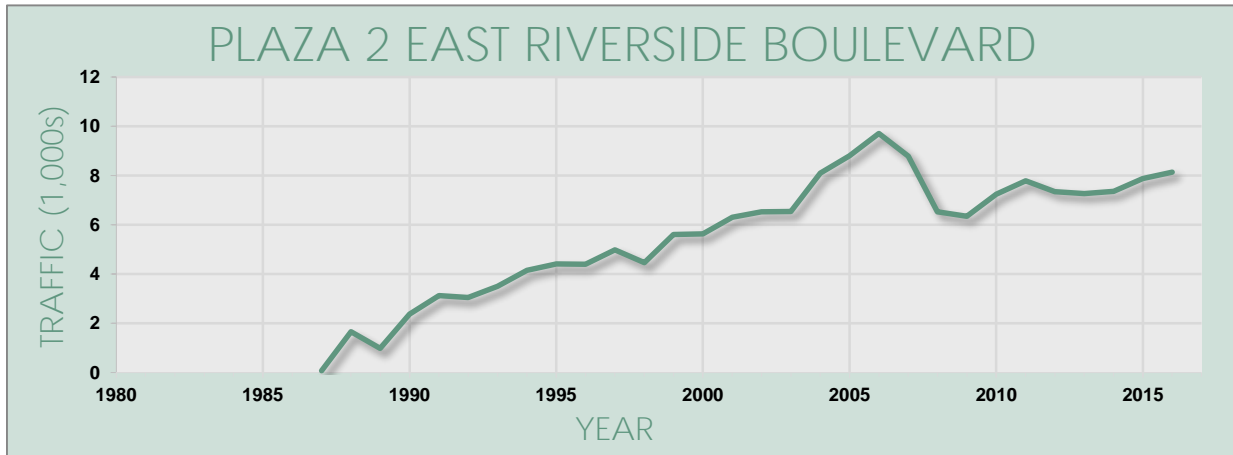
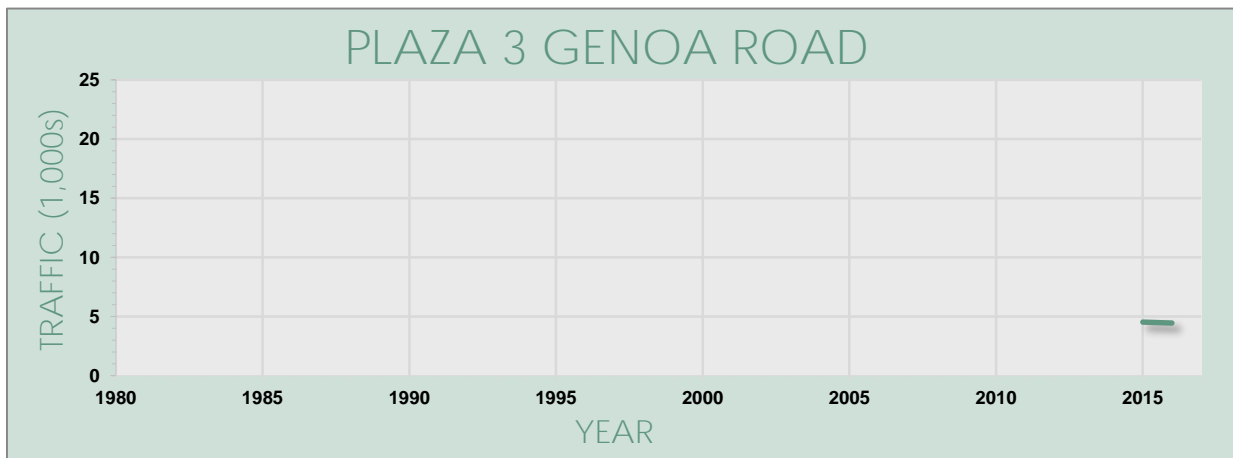

FIGURE 2-K

Genoa Road opened September 2015.



AVERAGE DAILY TRAFFIC TRENDS



FIGURE 2-L

Plaza 4 opened in 2007.

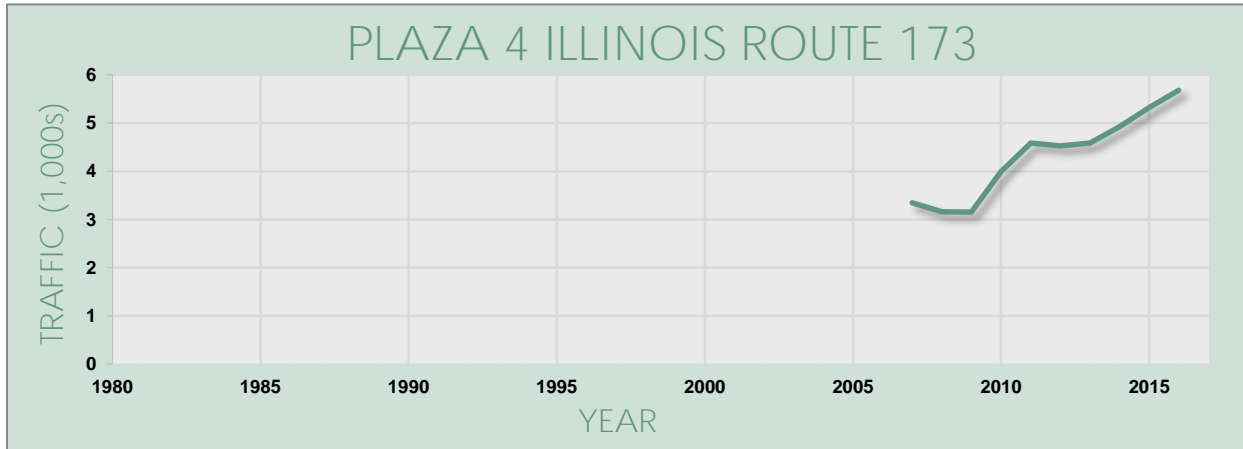

FIGURE 2-M

Plaza 5 converted to one way tolling (WB) in 2006.

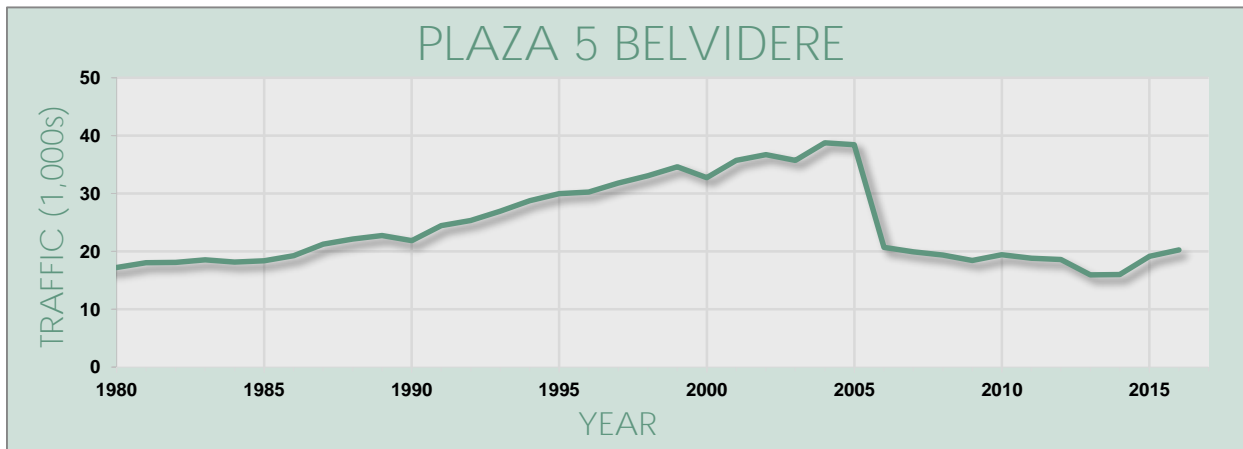
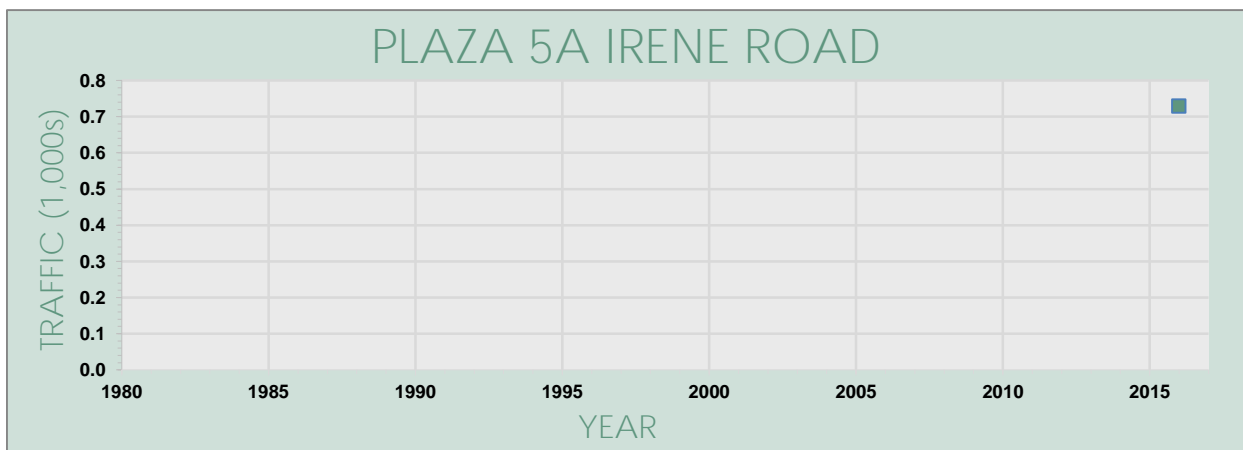

FIGURE 2-N

Plaza 5A opened in January 2016.



AVERAGE DAILY TRAFFIC TRENDS



FIGURE 2-O

Plaza 6 opened in 2013.

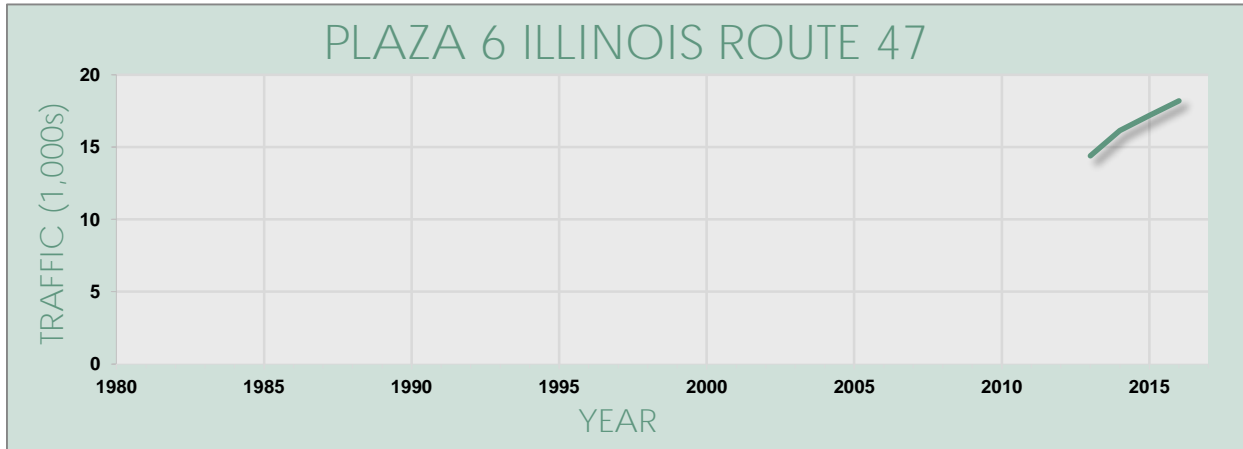

FIGURE 2-P

Plaza 7 converted to one way tolling (EB) in 2006.

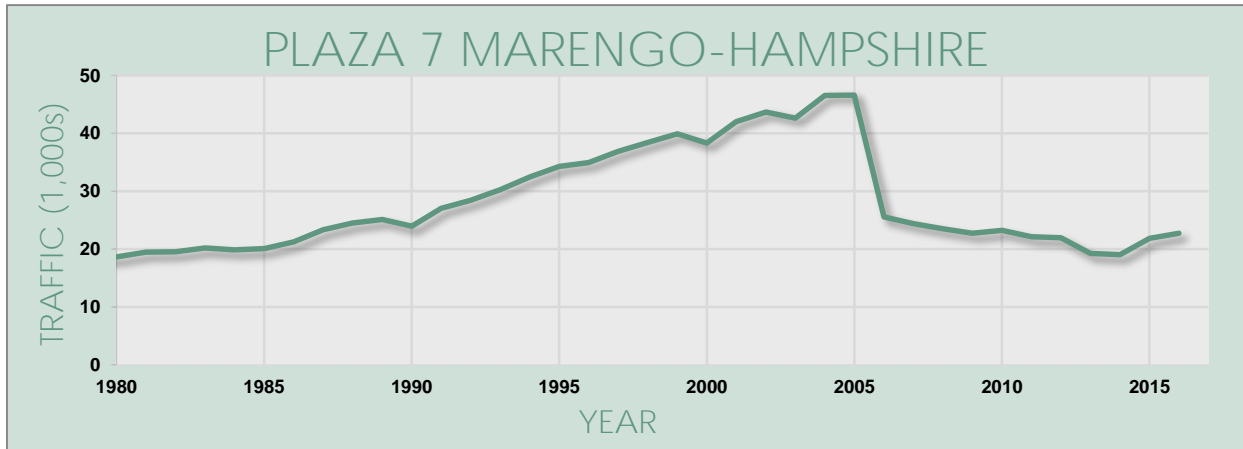
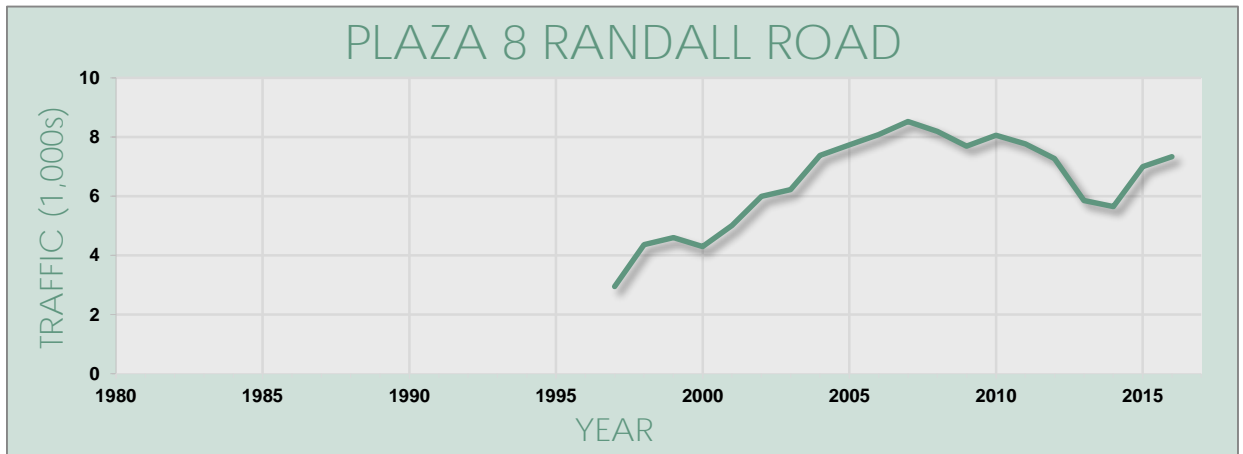

FIGURE 2-Q

Ramps to and from the west opened in 1997.



AVERAGE DAILY TRAFFIC TRENDS



FIGURE 2-R

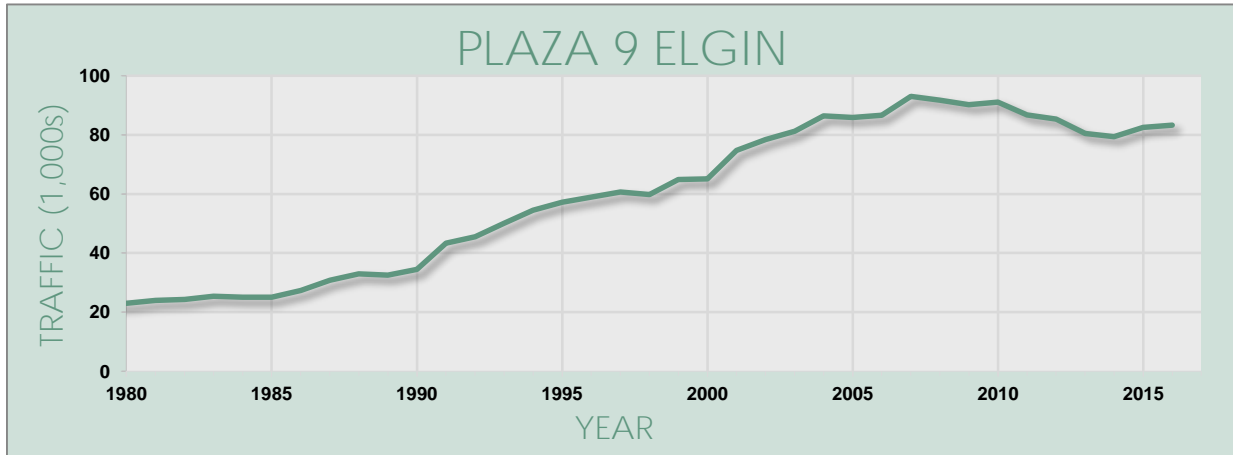

FIGURE 2-S

Plaza 10 opened in 1998 due to Plaza 15 reconfiguration.

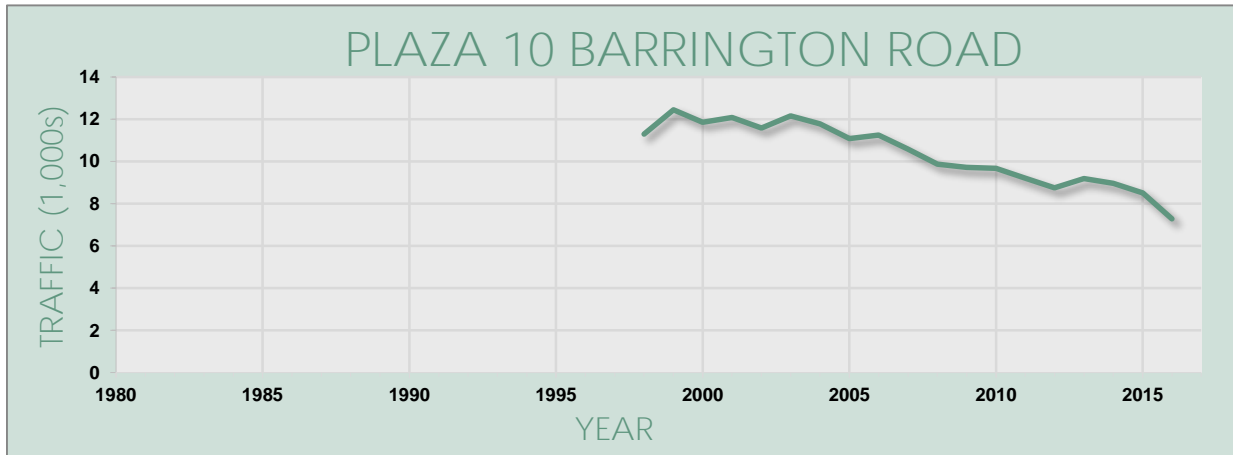
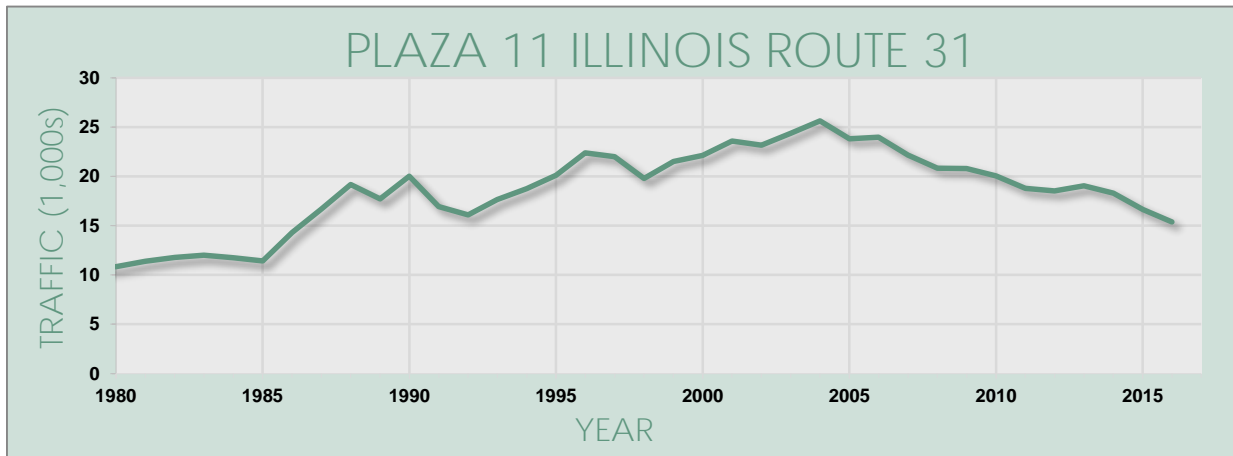

FIGURE 2-T



AVERAGE DAILY TRAFFIC TRENDS



FIGURE 2-U

Plaza 12 opened in 1998 due to Plaza 15 reconfiguration..

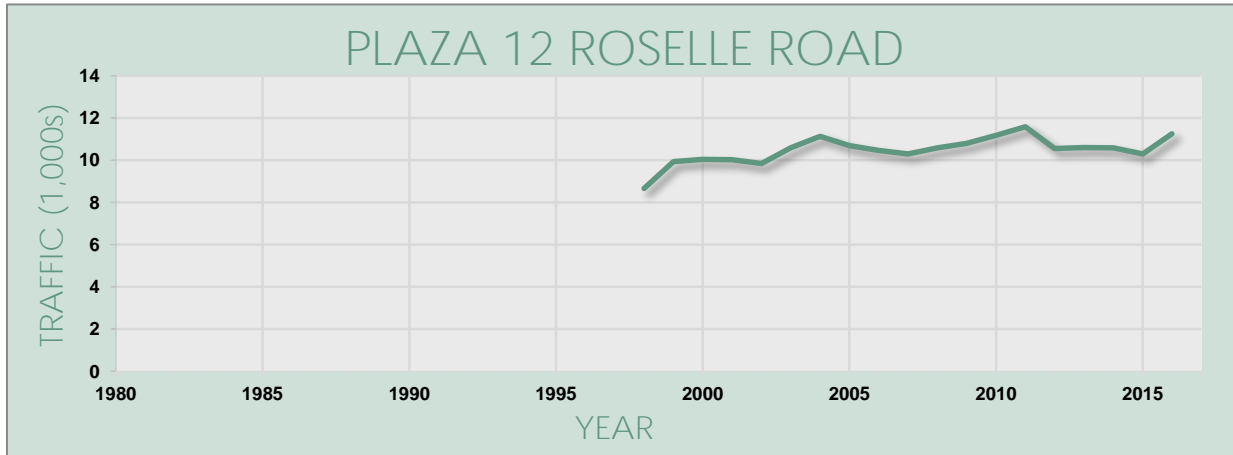
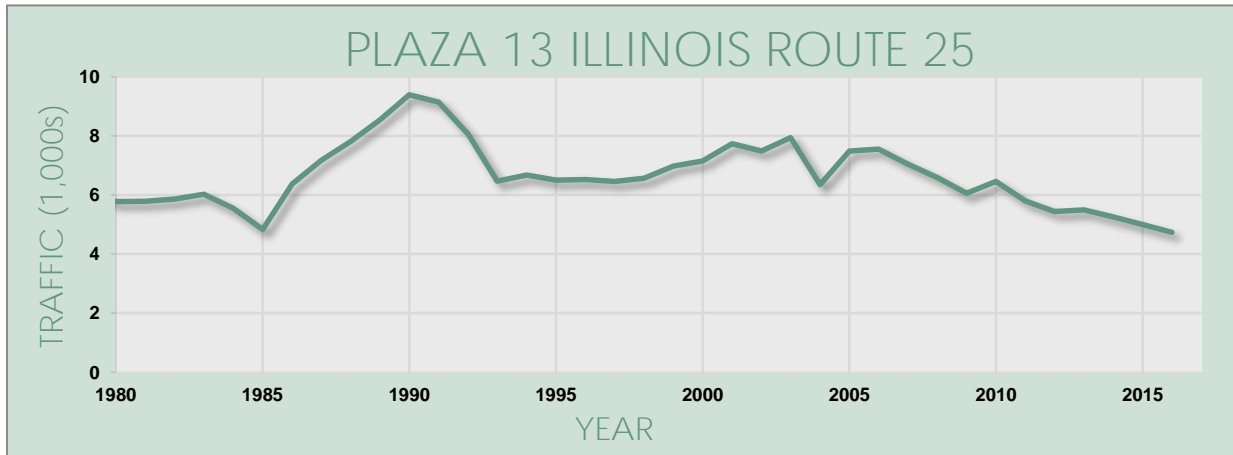
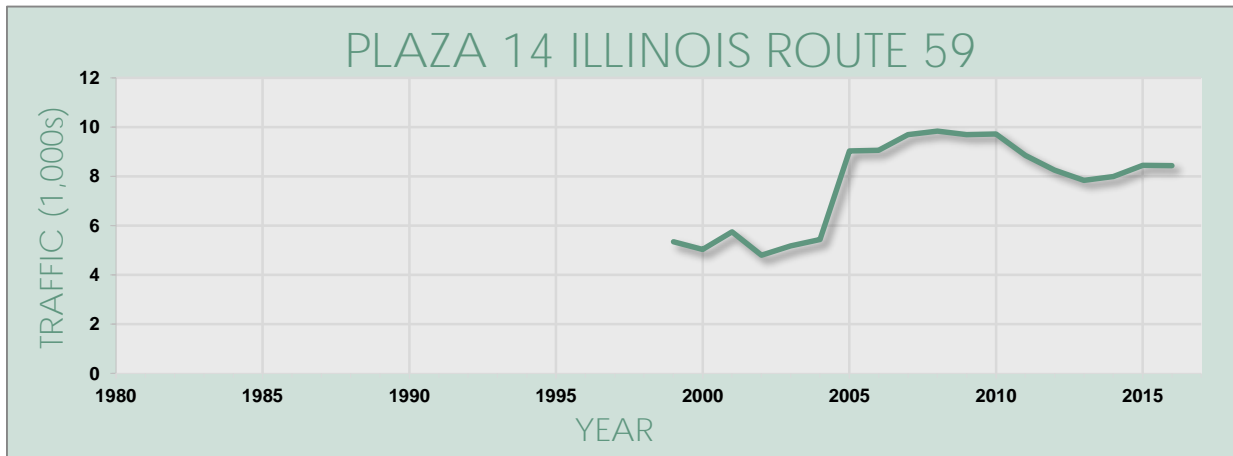

FIGURE 2-V



Note: The Plaza 14 graph shows transactions at the EB I-90 to Illinois Route 59 collection point only. Transactions for the WB I-90 to Illinois Route 59 collection point are included with the Plaza 16 graph. Plazas opened in 1998 due to Plaza 15 reconfiguration.

FIGURE 2-W



AVERAGE DAILY TRAFFIC TRENDS



FIGURE 2-X

Westbound tolls removed in 1997.

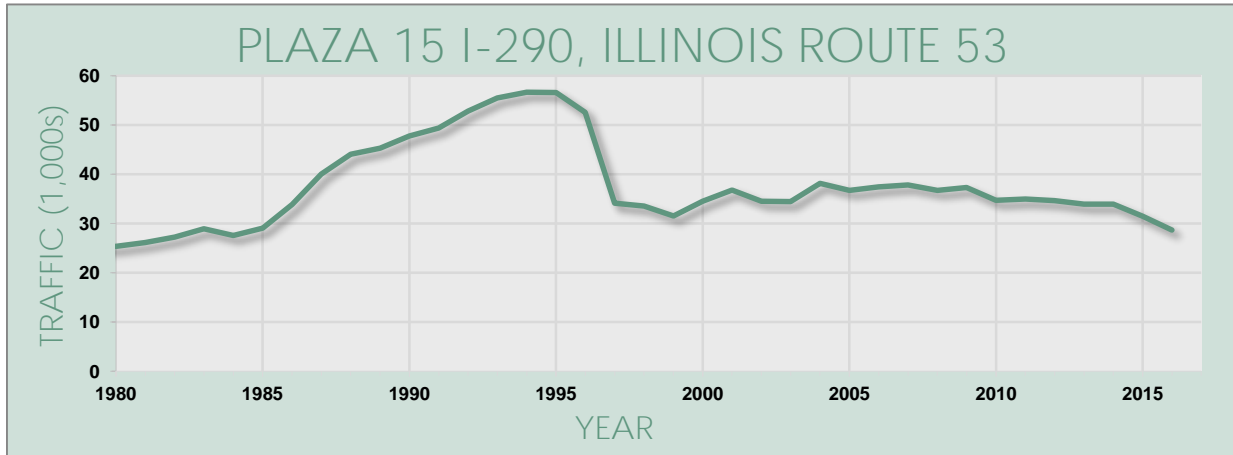

FIGURE 2-Y

Note: The Plaza 16 graph shows transactions from two collection points: (1) WB I-90 to Illinois Route 59 (Plaza 16a) and (2) WB I-90 to Beverly Road (Plaza 16b). Plaza 16b opened in 1995.

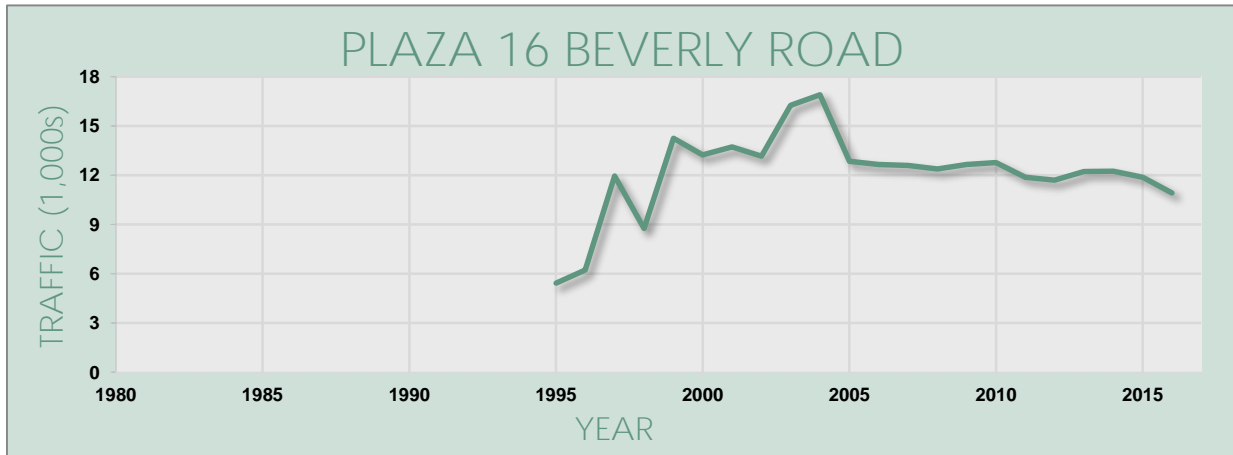
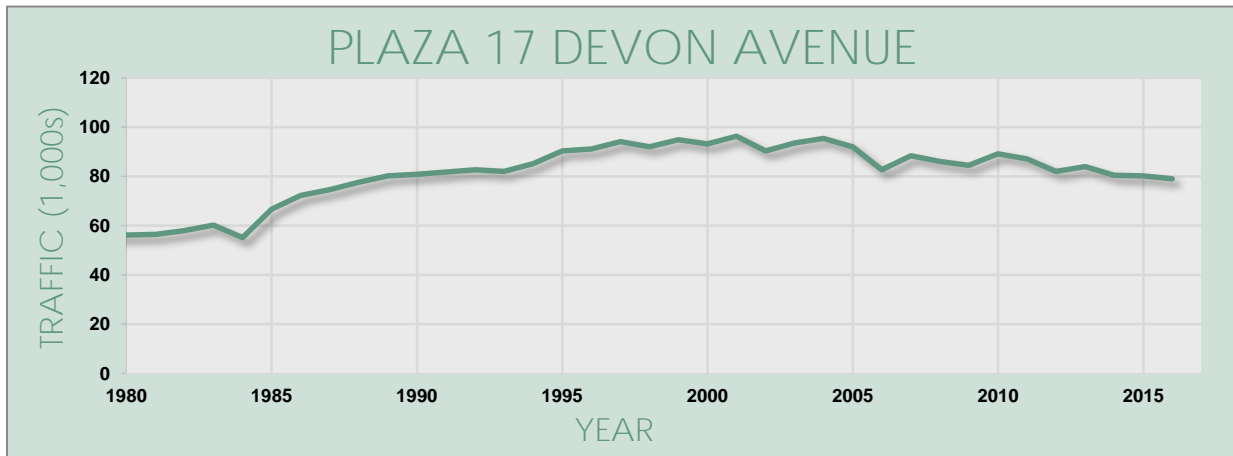

FIGURE 2-Z



AVERAGE DAILY TRAFFIC TRENDS



FIGURE 2-AA

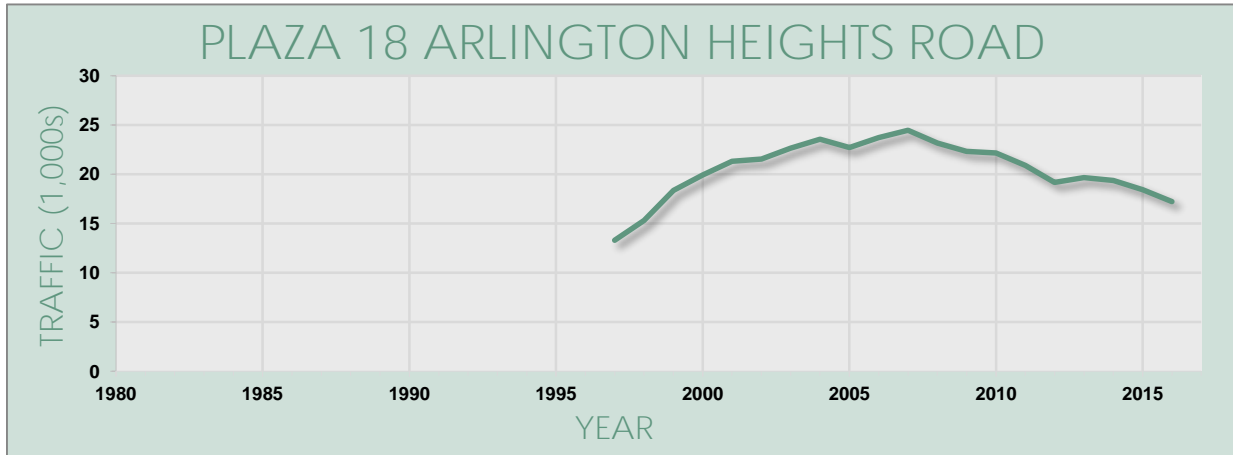
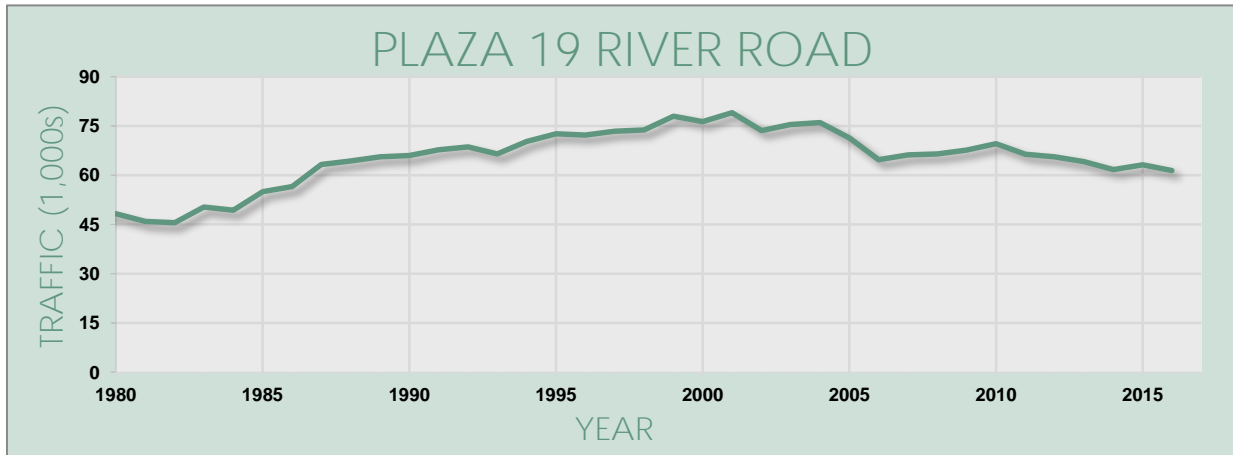

FIGURE 2-AB



AVERAGE DAILY TRAFFIC TRENDS



AVERAGE WEEKDAY SPEED DISTRIBUTIONS, EASTERN SECTION

FIGURE 2-AC

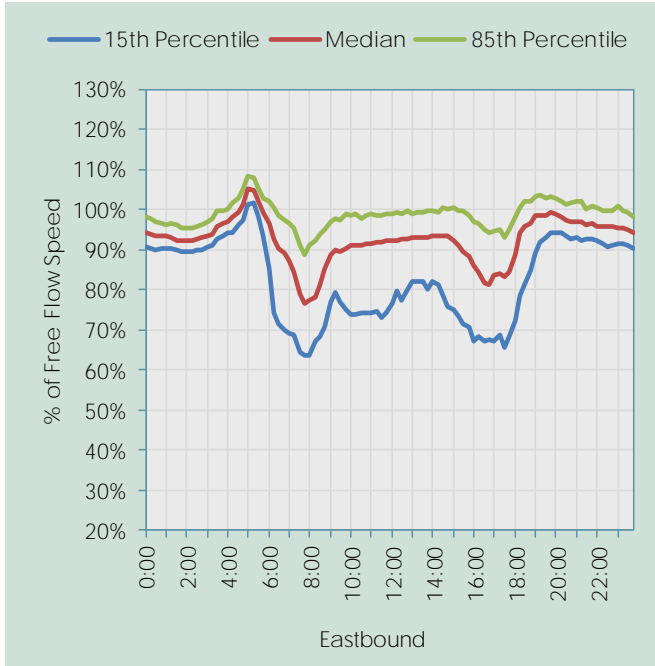
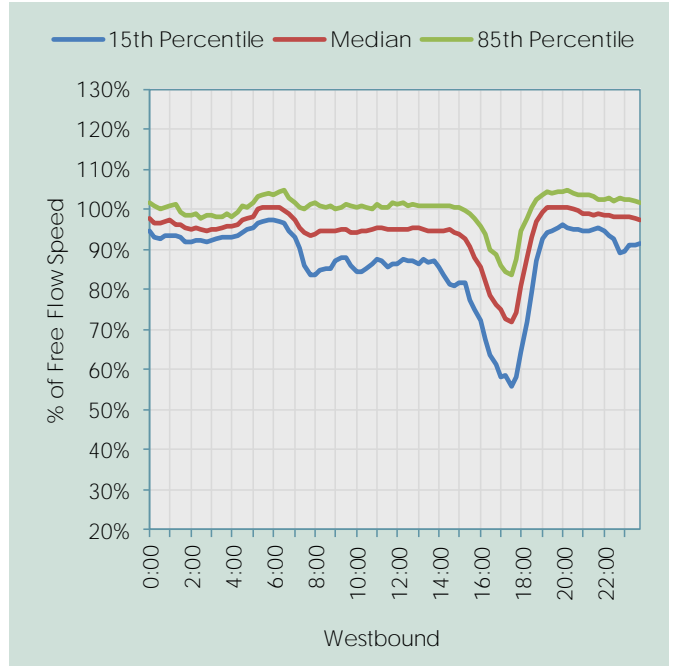

FIGURE 2-AD



AVERAGE WEEKDAY SPEED DISTRIBUTIONS, WESTERN SECTION

FIGURE 2-AE

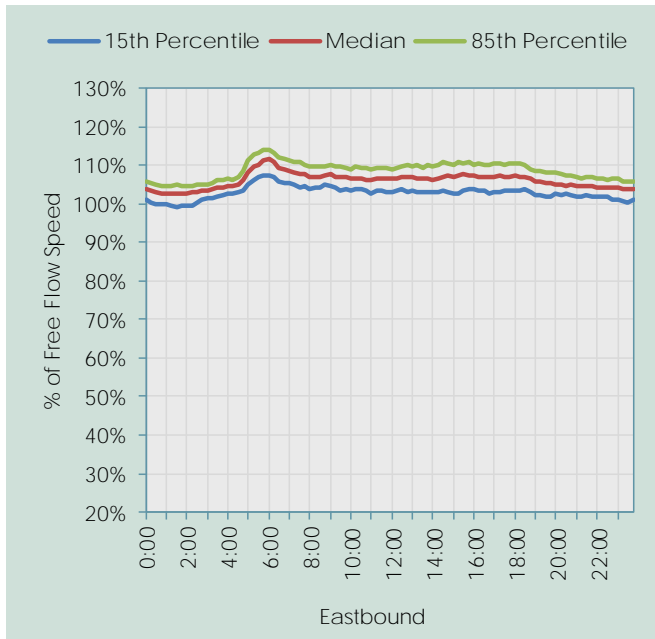
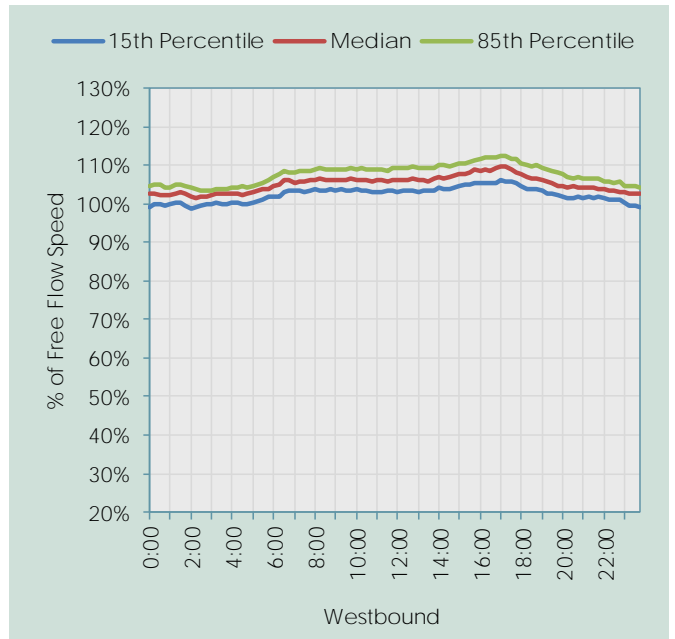
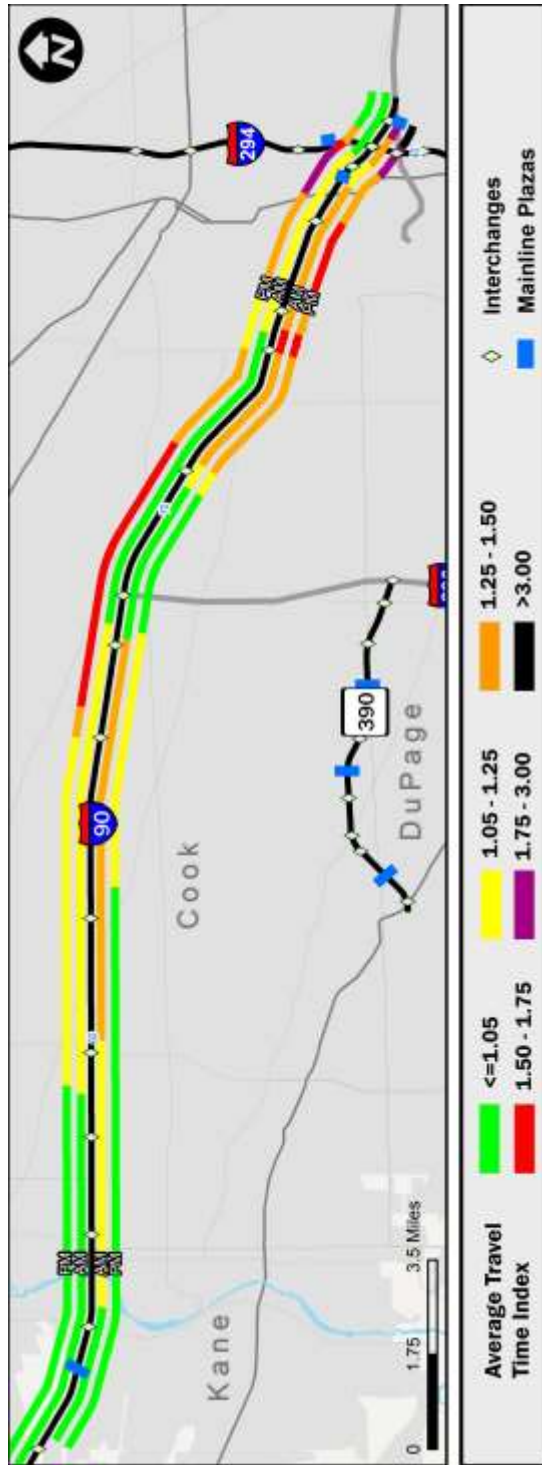

FIGURE 2-AF





Quarter	Range	Average Speed (mph)		Average Travel Time Index		Planning Time Index		Total Delay (veh-hrs / 1000 VMT)		Average Daily Delay (veh-hrs)		Percent Congested Travel	
		AM	PM	AM	PM	AM	PM	AM	PM	AM	PM	AM	PM
1	January -March	53	52	1.12	1.16	1.28	1.34	2.3	2.9	1,231	1,594	62	64
2	April-June	51	46	1.19	1.29	1.34	1.45	3.2	5.0	1,830	2,744	79	73
3	July-September	51	45	1.18	1.33	1.32	1.49	3.0	5.6	1,672	3,148	82	73
4	October-December	55	48	1.08	1.26	1.24	1.59	1.8	4.7	933	2,527	56	58
Total	2016 Entire Year	53	48	1.14	1.26	1.30	1.47	2.6	4.6	1,416	2,503	70	67

Data source: INRIX. Roadway performance measures sections and terms are defined on pages 1-4 and 1-5.

FIGURE 2-AG: ROADWAY PERFORMANCE MEASURES—EASTERN SECTION

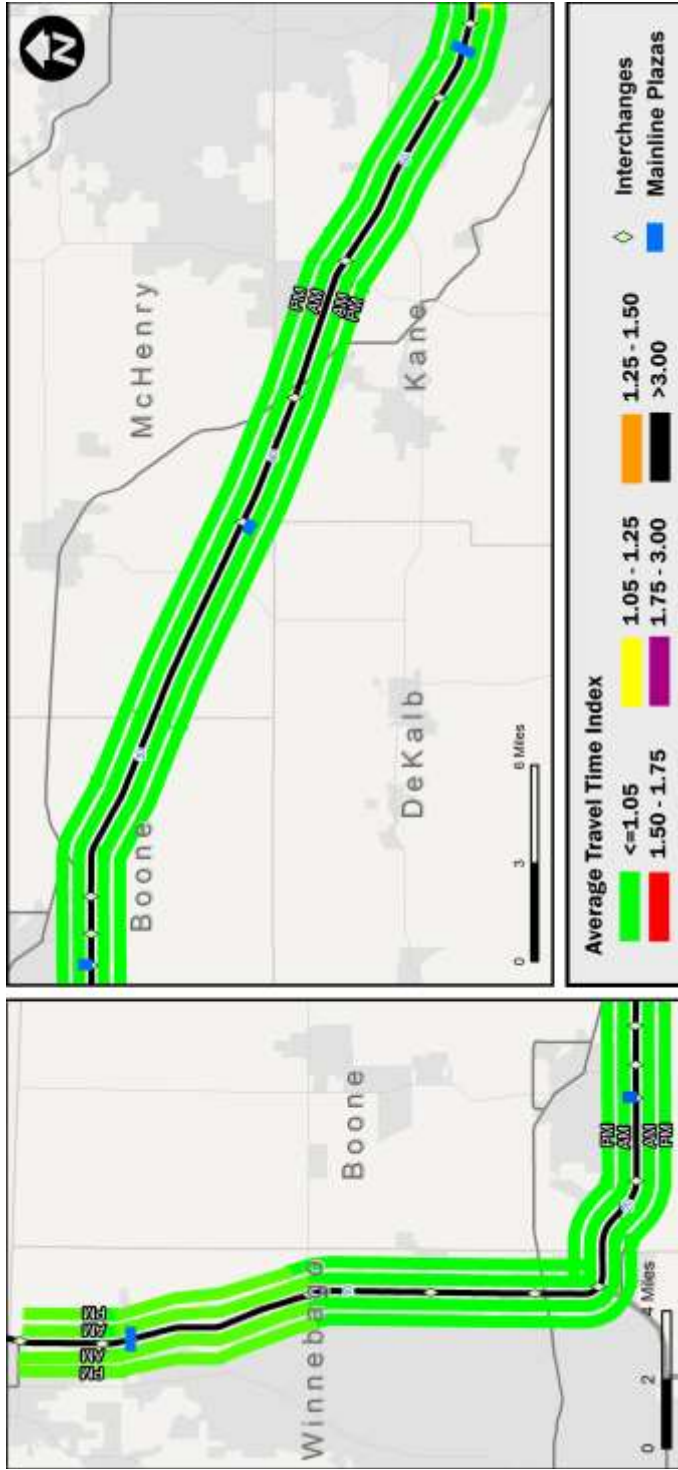

Quarter	Range	Average Speed (mph)		Average Travel Time Index		Planning Time Index		Total Delay (veh-hrs / 1000 VMT)		Average Daily Delay (veh-hrs)		Percent Congested Travel	
		AM	PM	AM	PM	AM	PM	AM	PM	AM	PM	AM	PM
1	January -March	64	65	0.93	0.93	0.97	0.95	0.3	0.3	131	155	10	11
2	April-June	65	65	0.92	0.92	0.94	0.94	0.2	0.3	107	177	10	11
3	July-September	64	64	0.93	0.93	0.96	0.95	0.4	0.5	194	285	10	11
4	October-December	64	64	0.94	0.94	0.96	0.96	0.4	0.5	180	261	10	12
Total	2016 Entire Year	64	64	0.93	0.93	0.96	0.95	0.4	0.4	153	219	10	11

Data source: INRIX. Roadway performance measures sections and terms are defined on pages 1-4 and 1-5.

FIGURE 2-AH: ROADWAY PERFORMANCE MEASURES—WESTERN SECTION

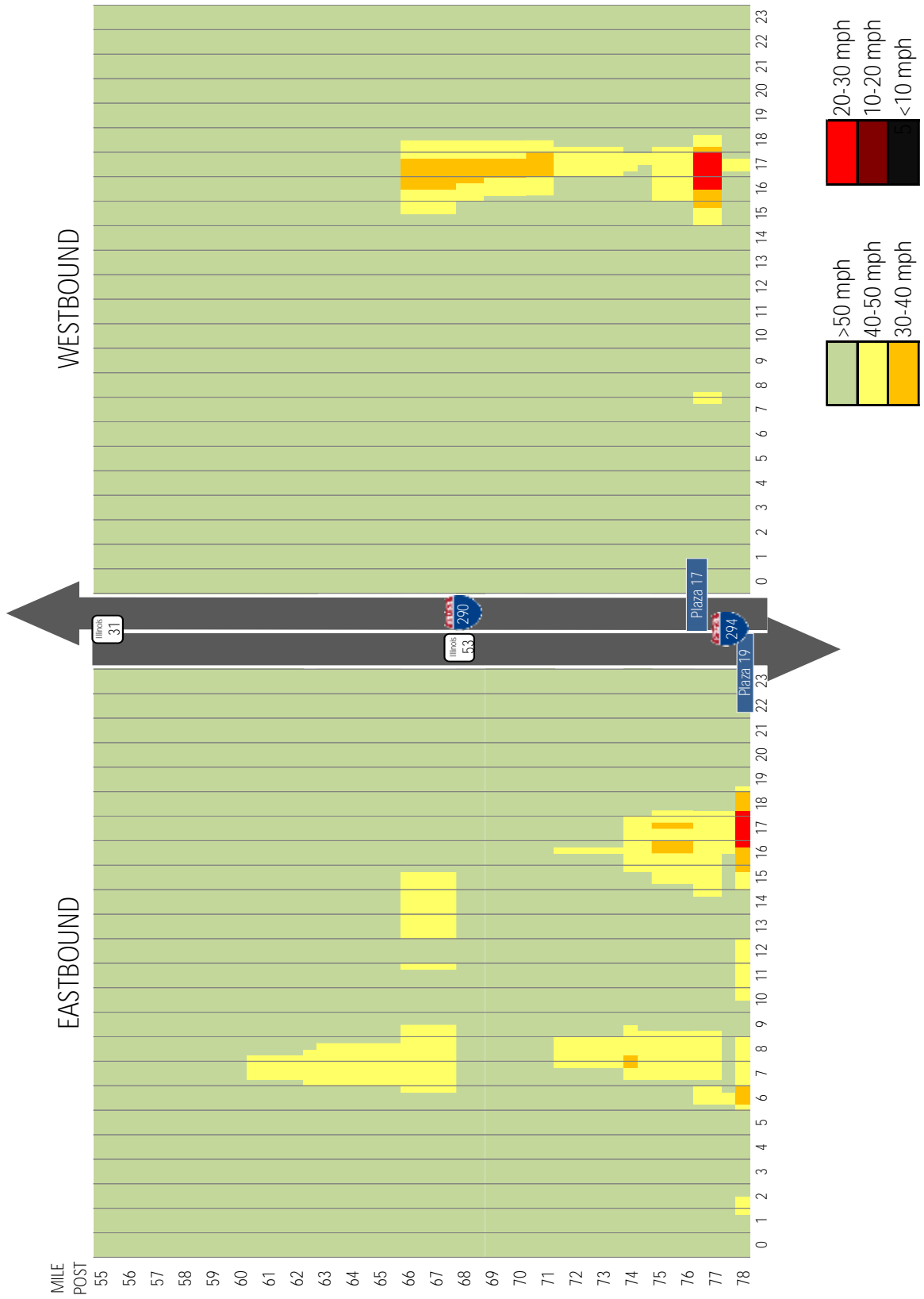

FIGURE 2-A1: AVERAGE SPEED CONTOURS MP 55.0 TO 78.5

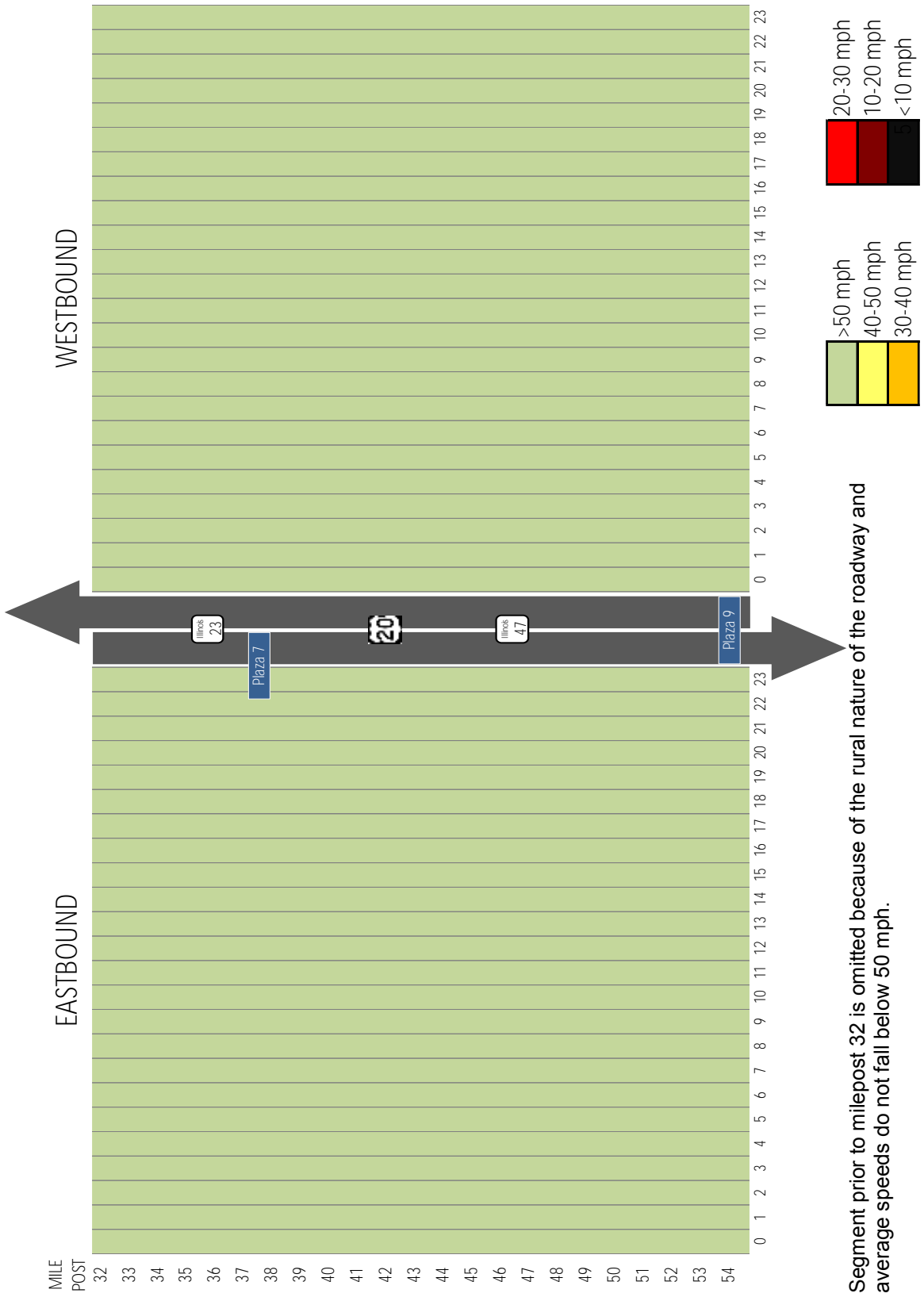

FIGURE 2-AJ: AVERAGE SPEED CONTOURS MP 32.0 TO 54.5

Segment prior to milepost 32 is omitted because of the rural nature of the roadway and average speeds do not fall below 50 mph.



Section 3

Tri-State Tollway



SECTION 3

Tri-State Tollway

TABULATIONS

TABLE	PAGE
3-A Average Daily Traffic Volumes Between Interchanges 1980 – 2016 (Northbound-1)	3-4
3-B Average Daily Traffic Volumes Between Interchanges 1980 – 2016 (Northbound-2)	3-5
3-C Average Daily Traffic Volumes Between Interchanges 1980 – 2016 (Southbound-1)	3-6
3-D Average Daily Traffic Volumes Between Interchanges 1980 – 2016 (Southbound-2)	3-7
3-E General Statistics for Mainline Plazas	3-8
3-F Indexed Monthly Variation by Mainline Plaza	3-10
3-G Indexed Daily Variation by Mainline Plaza	3-10
3-H Annual Total Transactions by Toll Plaza	3-11
3-I Average Daily Traffic Data	3-12

ILLUSTRATIONS

FIGURE	PAGE
3-A Mainline Plaza Highest Hourly Volume Plaza 21 NB	3-13
3-B Mainline Plaza Highest Hourly Volume Plaza 21 SB	3-13
3-C Mainline Plaza Highest Hourly Volume Plaza 24 EB	3-13
3-D Mainline Plaza Highest Hourly Volume Plaza 24 WB	3-13
3-E Mainline Plaza Highest Hourly Volume Plaza 29 NB	3-14
3-F Mainline Plaza Highest Hourly Volume Plaza 33 SB	3-14
3-G Mainline Plaza Highest Hourly Volume Plaza 35 NB	3-14
3-H Mainline Plaza Highest Hourly Volume Plaza 35 SB	3-14
3-I Mainline Plaza Highest Hourly Volume Plaza 36 SB	3-15
3-J Mainline Plaza Highest Hourly Volume Plaza 39 NB	3-15
3-K Mainline Plaza Highest Hourly Volume Plaza 41 NB	3-15
3-L Mainline Plaza Highest Hourly Volume Plaza 41 SB	3-15
3-M Average Daily Traffic Trends Plaza 20 Buckley Road	3-16
3-N Average Daily Traffic Trends Plaza 21 Waukegan	3-16
3-O Average Daily Traffic Trends Plaza 22 Townline Road	3-16
3-P Average Daily Traffic Trends Plaza 23 Half Day Road	3-17
3-Q Average Daily Traffic Trends Plaza 24 Edens Spur	3-17



SECTION 3

Tri-State Tollway

ILLUSTRATIONS (CONTINUED)

FIGURE	PAGE
3-R Average Daily Traffic Trends Plaza 25 Deerfield Road	3-17
3-S Average Daily Traffic Trends Plaza 26 Lake Cook Road	3-18
3-T Average Daily Traffic Trends Plaza 27 Willow Road	3-18
3-U Average Daily Traffic Trends Plaza 28 Golf Road	3-18
3-V Average Daily Traffic Trends Plaza 29 Touhy Avenue	3-19
3-W Average Daily Traffic Trends Plaza 30 Balmoral Avenue	3-19
3-X Average Daily Traffic Trends Plaza 31 O'Hare West	3-19
3-Y Average Daily Traffic Trends Plaza 32 O'Hare East	3-20
3-Z Average Daily Traffic Trends Plaza 33 Irving Park Road	3-20
3-AA Average Daily Traffic Trends Plaza 34 Willow Springs Road	3-20
3-AB Average Daily Traffic Trends Plaza 35 Cermak Road	3-21
3-AC Average Daily Traffic Trends Plaza 37 I-55	3-21
3-AD Average Daily Traffic Trends Plaza 38 95th Street	3-21
3-AE Average Daily Traffic Trends Plaza 36 & 39 (82nd Street & 83rd Street)	3-22
3-AF Average Daily Traffic Trends Plaza 40 159th Street	3-22
3-AG Average Daily Traffic Trends Plaza 41 163rd Street	3-22
3-AH Average Daily Traffic Trends Plaza 42 I-57, 147th Street	3-23
3-AI Average Daily Traffic Trends Plaza 43 & 45 I-80	3-23
3-AJ Average Daily Traffic Trends Plaza 47 Halsted Street	3-23
3-AK Average Weekday Speed Distributions, Northern Section—Eastbound	3-24
3-AL Average Weekday Speed Distributions, Northern Section—Westbound	3-24
3-AM Average Weekday Speed Distributions, North Central Section—Northbound	3-24
3-AN Average Weekday Speed Distributions, North Central Section—Southbound	3-24
3-AO Average Weekday Speed Distributions, South Central Section—Northbound	3-25
3-AP Average Weekday Speed Distributions, South Central Section—Southbound	3-25
3-AQ Average Weekday Speed Distributions, Southern Section—Northbound	3-25
3-AR Average Weekday Speed Distributions, Southern Section—Southbound	3-25
3-AS Roadway Performance Measures, Northern Section	3-26
3-AT Roadway Performance Measures, North Central Section	3-27
3-AU Roadway Performance Measures, South Central Section	3-28



SECTION 3

Tri-State Tollway

ILLUSTRATIONS (CONTINUED)

FIGURE	PAGE
--------	------

3-AV	Roadway Performance Measures, Southern Section	3-29
------	--	------

3-AW	Average Speed Contours, I-94 MP 0.0 to 29.5	3-30
------	---	------

3-AX	Average Speed Contours, I-294 MP 24.5 to 52.5	3-31
------	---	------

3-AY	Average Speed Contours, I-294 MP 0.5 to 24.0	3-32
------	--	------



TABLE 3-A: AVERAGE DAILY TRAFFIC VOLUMES BETWEEN INTERCHANGES 1980-2016 (NORTHBOUND-1)

Location	Mile Post	Miles Btwn. Int.	ADT 1980	Average Annual Percent Change	ADT 1990	Average Annual Percent Change	ADT 2000	Average Annual Percent Change	ADT 2010	Average Annual Percent Change	ADT 2016
Bishop Ford Freeway/Calumet Expy	0.0										
		0.8	32,090	5.0	52,400	1.4	60,000	2.2	74,800	2.8	88,470
Lincoln Oasis	0.8										
		1.9	32,090	5.0	52,400	1.4	60,000	2.2	74,800	2.8	88,470
Halsted Street (PL47)	2.7										
		1.3	30,070	5.1	49,550	1.2	55,610	2.8	73,290	2.3	83,870
Wood Street	4.0										
		0.2	32,700	5.1	53,610	0.8	57,980	2.8	76,610	2.3	87,900
Dixie Highway	4.2										
		0.9	32,700	5.1	53,610	0.8	57,980	2.8	76,610	2.3	87,900
I-80 (PL43 & 45)	5.1										
Toll Plaza 41	5.6	1.2	25,440	4.9	40,940	-0.4	39,520	2.4	49,880	1.3	53,900
159th Street (PL40)	6.3										
		1.7	24,250	4.9	39,250	1.6	45,790	1.0	50,740	1.2	54,360
I-57/147th Street	8.0										
		4.0	24,250	4.9	39,250	1.6	45,790	1.0	50,740	6.0	71,780
Cicero Avenue (Illinois Route 50)	12.0										
		5.5	26,970	4.9	43,610	2.9	58,210	-0.3	56,490	4.8	74,840
95th Street (PL38)	17.5										
Toll Plaza 39	19.5	2.8	35,890	4.2	53,970	2.8	70,920	-0.7	66,260	3.5	81,260
79th Street/Archer Avenue	20.3										
		1.7	33,380	4.2	50,370	3.5	70,920	-0.7	66,260	3.5	81,260
Willow Springs Road (PL34)	22.0										
		1.1	33,380	4.2	50,370	3.5	71,300	-0.7	66,630	3.4	81,660
I-55 EB	23.1										
		0.2	31,230	4.2	47,190	3.4	65,740	-0.4	63,070	2.9	74,940
Wolf Road & I-55 WB	23.3										
		0.8	28,380	3.8	41,260	2.8	54,250	0.2	55,330	2.0	62,420
Toll Plaza 37 (I-55)	24.1										
		0.9	45,400	3.3	62,620	2.0	76,420	0.8	83,150	1.7	91,860
Hinsdale Oasis	25.0										
		2.4	45,400	3.3	62,620	2.4	79,570	0.8	86,270	1.7	95,430
Ogden Avenue (U.S. Route 34)	27.4										
		1.6	44,710	3.5	62,980	2.1	77,300	1.0	85,260	1.8	95,030
Reagan Connector	29.0										
		0.5	37,610	2.8	49,760	2.2	62,050	0.6	66,010	1.6	72,720
Cermak Road	29.5										
Toll Plaza 35	29.9	1.0	39,360	2.9	52,420	2.4	66,410	0.3	68,280	2.2	77,980
Roosevelt Road (IL38)	30.5										
		0.6	37,590	2.9	49,900	2.1	61,270	0.6	64,930	2.1	73,450
Reagan Memorial Tollway (I-88)	31.1										
		0.5	44,050	0.8	47,710	1.2	53,500	1.9	64,820	2.3	74,490
Eisenhower Expressway (I-290)	31.6										
		2.0	40,130	2.5	51,370	1.7	60,900	1.3	69,560	2.8	82,020
Illinois Route 64 & U.S. Route 20	33.6										
		4.2	47,320	2.6	61,300	1.9	74,020	1.0	81,990	2.7	96,040
O'Hare Oasis	37.8										
		0.5	47,320	2.6	61,300	1.9	74,020	1.0	81,990	2.7	96,040
Irving Park Road (Illinois Route 19)	38.3										
Toll Plaza 33	38.9	1.5	53,050	3.1	71,830	1.7	85,080	1.0	93,650	2.7	109,740
Balmoral Avenue	39.8										



TABLE 3-B: AVERAGE DAILY TRAFFIC VOLUMES BETWEEN INTERCHANGES 1980-2016 (NORTHBOUND-2)

Location	Mile Post	Miles Btwn. Int.	ADT 1980	Average Annual Percent Change	ADT 1990	Average Annual Percent Change	ADT 2000	Average Annual Percent Change	ADT 2010	Average Annual Percent Change	ADT 2016
Balmoral Avenue	39.8										
Kennedy Expressway (I-190)	40.5	1.1	53,050	3.1	71,830	1.7	85,080	1.0	93,650	0.8	98,500
Jane Addams Interchange	40.9										
Toll Plaza 29	41.6	1.2	45,770	4.1	68,690	2.0	83,800	-0.1	82,840	2.7	96,980
Touhy Avenue	42.1										
		2.1	39,730	4.3	60,690	2.1	74,390	0.3	76,590	2.0	86,050
Dempster Street (U.S. Route 14)	44.2										
		1.0	29,250	4.0	43,230	2.4	55,050	0.1	55,450	2.2	63,210
Golf Road (Illinois Route 58)	45.2										
		3.7	33,080	4.3	50,550	2.3	63,640	0.0	63,340	2.2	72,250
Willow Road (PL27)	48.9										
		3.9	21,750	6.6	41,210	2.9	55,010	0.1	55,480	2.2	63,050
Lake Cook Road	52.8										
Edens Spur	30.0										
		2.3	8,120	8.5	18,300	2.3	22,880	-0.7	21,420	2.2	24,430
Waukegan Road	27.7										
		2.5	10,350	7.2	20,760	1.9	25,010	-0.3	24,280	2.8	28,660
Tri-State Tollway	25.2										
Lake Cook Road / I-94 / I-294	25.2										
		1.0	32,100	6.0	57,460	2.0	69,970	0.9	76,390	2.6	88,960
Deerfield Road	24.2										
		2.4	29,180	5.6	50,360	2.3	63,280	1.4	72,870	2.6	85,250
Half Day Road (Illinois Route 22/PL 23)	21.8										
		2.9	28,600	5.5	48,980	2.5	62,960	0.8	68,200	2.8	80,710
Town Line Road (Illinois Route 60/PL 22)	18.9										
		0.8	26,050	5.8	45,830	2.9	61,020	0.2	62,510	2.6	73,110
Lake Forest Oasis	18.1										
		2.1	26,050	5.8	45,830	2.9	61,020	0.2	62,510	2.6	73,110
Rockland Avenue (Illinois Route 176)	16.0										
		2.2	24,220	5.6	41,940	3.1	56,670	0.3	58,280	2.3	66,810
Buckley Road (Illinois Route 137)	13.8										
		2.6	22,310	5.5	38,070	3.3	52,860	0.3	54,570	1.9	61,160
Belvidere Road (Illinois Route 120)	11.2										
		1.1	18,840	5.1	31,010	3.2	42,380	0.5	44,450	1.2	47,760
Milwaukee Avenue (Illinois Route 21)	10.1										
		1.7	19,580	5.2	32,400	3.3	44,640	0.6	47,290	1.5	51,680
Grand Avenue (Illinois Route 132)	8.4										
Toll Plaza 21	4.8	6.0	13,440	5.6	23,220	2.8	30,650	0.4	31,920	3.3	38,840
Rosecrans Road (Illinois Route 173)	2.4										
		1.2	12,580	5.4	21,250	2.6	27,590	0.3	28,340	3.2	34,270
Mill Creek Road	1.2										
		0.4	12,580	5.4	21,250	2.6	27,590	0.3	28,340	3.2	34,270
Skokie Highway (U.S. Route 41)	0.8										



TABLE 3-C: AVERAGE DAILY TRAFFIC VOLUMES BETWEEN INTERCHANGES 1980-2016 (SOUTHBOUND-1)

Location	Mile Post	Miles Btwn. Int.	ADT 1980	Average Annual Percent Change	ADT 1990	Average Annual Percent Change	ADT 2000	Average Annual Percent Change	ADT 2010	Average Annual Percent Change	ADT 2016
Bishop Ford Freeway/Calumet Expy	0.0										
		0.8	32,160	4.9	51,770	0.9	56,630	2.9	75,700	2.4	87,200
Lincoln Oasis	0.8										
		1.9	32,160	4.9	51,770	0.9	56,630	2.9	75,700	2.4	87,200
Halsted Street (Pl 47)	2.7										
		1.3	30,260	5.0	49,300	0.8	53,380	3.1	72,100	2.3	82,480
Wood Street	4.0										
		0.2	30,260	5.0	49,300	0.8	53,380	3.1	72,100	2.3	82,480
Dixie Highway	4.2										
		0.9	33,000	4.9	53,370	0.7	57,100	2.9	75,790	2.0	85,510
I-80 (PL 43 & 45)	5.1										
Toll Plaza 41	5.6	1.2	25,850	4.7	40,770	-0.4	39,050	2.4	49,600	1.2	53,170
159th Street (PL46)	6.3										
		1.7	24,400	4.8	39,050	1.2	44,180	1.2	49,570	1.2	53,110
I-57/147th Street	8.0										
		4.0	24,400	4.8	39,050	1.2	44,180	1.2	49,570	5.7	69,150
Cicero Avenue (Illinois Route 50)	12.0										
		5.5	27,290	4.6	42,590	2.8	56,350	-0.4	54,280	5.0	72,820
95th Street (U.S. Routes 12&20)	17.5										
Toll Plaza 36	19.5	2.8	35,750	4.0	53,170	2.9	70,920	-0.5	67,510	3.6	83,380
79th Street/Archer Avenue	20.3										
		1.7	30,530	4.0	45,290	3.8	65,790	-0.4	63,000	2.9	74,990
Willow Springs Road/75th Street	22.0										
		1.1	30,530	4.0	45,290	4.1	67,370	-0.4	64,420	2.4	74,400
Interstate 55 (No SB Ramps)	23.1										
		0.2	30,530	4.0	45,290	4.1	67,370	-0.4	64,420	-0.2	63,820
Wolf Road & NB I-55 Entrance	23.3										
		0.8	27,460	3.3	37,980	3.6	54,270	0.2	55,200	2.4	63,820
Interstate 55	24.1										
		0.9	45,140	3.0	60,840	2.9	80,730	0.6	86,050	1.9	96,410
Hinsdale Oasis	25.0										
		2.4	45,140	3.0	60,840	2.9	80,730	0.6	86,050	1.9	96,410
Ogden Avenue (U.S. Route 34)	27.4										
		1.6	44,450	3.2	60,940	2.9	80,940	0.6	86,180	1.5	94,020
Reagan Connector	29.0										
		0.5	37,400	2.5	47,760	3.7	68,440	-0.2	67,060	1.1	71,590
Cermak Road	29.5										
Toll Plaza 35	29.9	1.0	39,160	2.5	50,330	3.6	71,370	-0.3	69,070	1.8	76,690
Roosevelt Road (Illinois Route 38)	30.5										
		0.6	37,330	2.6	48,030	3.5	67,520	-0.4	65,020	1.5	71,170
Reagan Memorial Tollway (I-88)	31.1										
		0.5	43,340	4.2	65,600	2.9	87,710	0.4	91,100	1.4	98,770
Eisenhower Expressway (I-290)	31.6										
		2.0	39,180	2.5	50,360	3.4	70,590	0.6	74,620	2.1	84,730
Illinois Route 64 & U.S. Route 20	33.6										
		4.2	46,280	2.7	60,310	3.2	82,840	0.3	85,070	2.3	97,530
O'Hare Oasis	37.8										
		0.5	46,280	2.7	60,310	3.2	82,840	0.3	85,070	2.3	97,530
Irving Park Road (Illinois Route 19)	38.3										
Toll Plaza 33	38.9	1.5	51,960	3.2	70,940	2.9	94,270	0.2	96,260	2.3	110,280
Balmoral Avenue	39.8										



TABLE 3-D: AVERAGE DAILY TRAFFIC VOLUMES BETWEEN INTERCHANGES 1980-2016 (SOUTHBOUND-2)

Location	Mile Post	Miles Btwn. Int.	ADT 1980	Average Annual Percent Change	ADT 1990	Average Annual Percent Change	ADT 2000	Average Annual Percent Change	ADT 2010	Average Annual Percent Change	ADT 2016
Balmoral Avenue	39.8										
	40.5	1.1	51,960	3.2	70,940	2.6	91,700	-0.2	90,200	2.2	102,760
O'Hare Interchange (I-90/I-294/I-190)	40.9										
Toll Plaza 29	41.6	1.2	45,980	4.5	71,500	1.0	79,140	-0.1	78,040	3.6	96,210
Touhy Avenue	42.1										
		2.1	39,940	4.8	63,660	0.9	69,290	-0.1	68,920	3.8	86,310
Dempster Street (U.S. Route 14)	44.2										
		1.0	29,520	4.6	46,460	0.6	49,170	0.0	49,030	4.0	61,940
Golf Road (Illinois Route 58)	45.2										
		3.7	33,480	4.8	53,510	0.8	57,890	-0.1	57,080	3.7	71,120
Willow Road (PL27)	48.9										
		3.9	22,130	7.2	44,410	1.2	50,280	0.3	51,810	3.8	64,700
Lake Cook Road	52.8										
Edens Expressway	30.0										
		2.3	8,500	8.0	18,420	2.3	23,100	-0.6	21,800	1.9	24,450
Waukegan Road	27.7										
		2.5	10,230	7.3	20,760	2.0	25,310	-0.1	25,010	2.5	28,920
Lake Cook Road / I-94 / I-294	25.2										
		1.0	32,360	6.5	60,480	1.6	70,900	0.8	76,560	3.6	94,390
Deerfield Road	24.2										
		2.4	29,260	6.2	53,160	2.0	64,960	0.7	69,920	3.6	86,540
Half Day Road (Illinois Route 22/PL23)	21.8										
		2.9	28,440	6.1	51,480	2.3	64,320	0.3	66,210	3.3	80,660
Town Line Road (Illinois Route 60/PL22)	18.9										
		0.8	25,900	6.4	48,000	2.6	62,080	-0.2	61,150	3.0	73,010
Lake Forest Oasis	18.1										
		2.1	25,900	6.4	48,000	2.6	62,080	-0.2	61,150	3.0	73,010
Rockland Road (Illinois Route 176)	16.0										
		2.2	24,080	6.2	43,780	2.8	57,680	0.0	57,430	2.5	66,790
Buckley Road (Illinois Route 137/PL20)	13.8										
		2.6	22,100	6.0	39,560	3.0	53,310	0.0	53,370	2.0	60,230
Belvidere Road (Illinois Route 120)	11.2										
		1.1	18,770	5.6	32,240	2.7	41,900	0.4	43,600	0.9	46,070
Milwaukee Avenue (Illinois Route 21)	10.1										
		1.7	19,580	5.5	33,590	2.8	44,350	0.5	46,680	1.3	50,580
Grand Avenue (Illinois Route 132)	8.4										
Toll Plaza 21	4.8	6.0	13,520	5.8	23,690	2.8	31,270	0.5	32,730	3.2	39,540
Rosecrans Road (Illinois Route 173)	2.4										
		1.2	12,380	5.8	21,740	2.5	27,960	0.3	28,800	3.1	34,560
U.S. Route 41	1.2										
		0.4	11,410	5.7	19,830	2.8	26,110	3.4	36,630	3.7	45,640
Russell Road (West Terminus)	0.8										



**TABLE 3-E: GENERAL STATISTICS FOR MAINLINE PLAZAS
(Vehicles/Hour)**

Mainline Plaza	Dir.	30th HV	Period	Mean	Med.	Max.	Min.	Std. Dev.	85th %
21 Waukegan	NB	4,516	AM Peak	1,609	1,608	2,050	1,073	199	1,825
			PM Peak	3,488	3,496	4,009	2,715	246	3,714
			OFF Peak	1,372	1,378	3,685	171	834	2,274
			Weekend	1,686	1,608	5,250	112	1,124	2,867
			Holidays	1,593	1,454	4,503	78	1,145	2,879
	SB	4,576	AM Peak	3,265	3,237	3,953	2,093	423	3,628
			PM Peak	1,977	1,967	2,735	1,359	215	2,185
			OFF Peak	1,408	1,553	3,353	149	816	2,298
			Weekend	1,691	1,699	5,339	148	1,100	2,842
			Holidays	1,719	1,614	5,982	128	1,260	2,976
24 Edens Spur	EB	2,682	AM Peak	2,388	2,411	2,854	1,861	211	2,591
			PM Peak	1,843	1,849	2,184	1,425	160	2,011
			OFF Peak	1,066	1,219	2,878	69	705	1,774
			Weekend	1,165	1,286	2,800	68	724	1,945
			Holidays	1,090	1,122	2,585	68	707	1,935
	WB	2,896	AM Peak	1,730	1,489	2,400	939	417	2,215
			PM Peak	2,523	2,534	2,966	1,682	210	2,728
			OFF Peak	1,067	1,070	2,806	80	731	1,897
			Weekend	1,143	1,115	3,129	78	733	1,967
			Holidays	1,014	930	2,919	58	716	1,749
29 Touhy Avenue	NB	8,693	AM Peak	7,750	7,673	8,942	5,419	743	8,542
			PM Peak	7,493	7,529	8,657	5,936	493	7,997
			OFF Peak	3,678	4,150	8,578	275	2,241	6,045
			Weekend	3,705	3,853	8,462	359	2,133	5,993
			Holidays	3,319	3,388	8,037	340	2,027	5,551
33 Irving Park Road	SB	8,772	AM Peak	7,261	6,727	9,044	4,560	1,180	8,650
			PM Peak	7,626	7,771	8,582	5,275	629	8,215
			OFF Peak	4,323	4,847	8,657	346	2,585	7,357
			Weekend	4,328	4,534	8,644	500	2,404	7,082
			Holidays	3,801	3,909	8,075	443	2,230	6,444

(cont'd)



**TABLE 3-E: GENERAL STATISTICS FOR MAINLINE PLAZAS
(Vehicles/Hour)**

Mainline Plaza	Dir.	30th HV	Period	Mean	Med.	Max.	Min.	Std. Dev.	85th %
35 Cermak Road	NB	6,061	AM Peak	5,396	5,315	6,264	3,988	508	5,953
			PM Peak	5,114	5,144	5,960	4,139	387	5,454
			OFF Peak	2,994	3,423	5,703	295	1,697	4,810
			Weekend	3,119	3,251	6,074	373	1,735	5,099
			Holidays	2,831	2,888	5,731	375	1,673	4,778
	SB	5,849	AM Peak	4,601	4,512	5,493	3,271	532	5,198
			PM Peak	4,571	4,621	5,465	3,094	433	4,982
			OFF Peak	3,067	3,356	6,052	261	1,743	4,908
			Weekend	3,067	3,180	6,070	321	1,673	4,992
			Holidays	2,729	2,763	5,896	272	1,569	4,600
36 82 nd Street	SB	7,819	AM Peak	4,355	4,213	5,350	2,837	599	5,055
			PM Peak	7,249	7,379	8,046	3,636	561	7,657
			OFF Peak	3,288	3,529	7,566	280	1,998	5,330
			Weekend	3,209	3,216	8,159	270	1,902	5,128
			Holidays	2,916	2,776	7,558	225	1,853	4,949
39 83 rd Street	NB	7,545	AM Peak	6,735	6,788	7,750	4,638	667	7,395
			PM Peak	5,098	5,109	6,032	3,194	459	5,531
			OFF Peak	3,094	3,358	6,300	319	1,776	5,088
			Weekend	3,183	3,210	7,574	346	1,841	5,243
			Holidays	2,952	2,952	7,270	295	1,823	5,069
41 163 rd Street	NB	4,527	AM Peak	4,110	4,125	4,641	3,019	332	4,454
			PM Peak	3,334	3,357	4,239	2,590	339	3,672
			OFF Peak	2,051	2,247	4,116	249	1,097	3,289
			Weekend	2,149	2,186	4,549	207	1,220	3,568
			Holidays	2,063	1,917	4,395	222	1,281	3,752
	SB	4,643	AM Peak	2,614	2,578	3,307	1,608	367	3,027
			PM Peak	4,139	4,185	4,782	2,004	315	4,404
			OFF Peak	2,106	2,285	4,622	264	1,144	3,334
			Weekend	2,103	2,102	4,863	179	1,188	3,429
			Holidays	1,931	1,850	4,307	174	1,164	3,361

AM Peak = Weekday 6:00 AM To 8:00 AM Except Fridays
 PM Peak = Weekday 4:00 PM To 6:00 PM Except Fridays
 OFF Peak = Weekdays Except Fridays and AM and PM Peak Periods
 Weekend = Fridays, Saturdays, and Sundays
 Holidays = See Page 1-6 for a list of Holidays.



TABLE 3-F: INDEXED MONTHLY VARIATION BY MAINLINE PLAZA

Month	Wau-kegan	Edens Spur	Touhy Avenue	Irving Park	Cermak Road	82nd Street	83rd Street	163rd Street
January	0.82	0.86	0.87	0.89	0.86	0.86	0.85	0.83
February	0.87	0.91	0.92	0.94	0.91	0.91	0.91	0.88
March	0.92	0.94	0.97	0.99	0.98	0.98	0.98	0.97
April	0.95	0.99	1.00	1.00	1.00	0.99	1.00	0.99
May	1.03	1.04	1.04	1.03	1.04	1.03	1.03	1.05
June	1.10	1.09	1.08	1.06	1.07	1.08	1.08	1.10
July	1.20	1.11	1.05	1.04	1.06	1.06	1.07	1.11
August	1.14	1.09	1.07	1.06	1.07	1.07	1.07	1.08
September	1.06	1.05	1.03	1.04	1.03	1.04	1.03	1.04
October	1.02	1.03	1.04	1.04	1.03	1.03	1.03	1.03
November	0.97	0.99	1.00	1.00	1.00	1.02	1.01	1.00
December	0.90	0.90	0.93	0.93	0.93	0.94	0.95	0.92

TABLE 3-G: INDEXED DAILY VARIATION BY MAINLINE PLAZA

Month	Day	Wau-kegan	Edens Spur	Touhy Avenue	Irving Park	Cermak Road	82nd Street	83rd Street	163rd Street
August	Monday	1.11	1.10	1.07	1.06	1.07	1.08	1.09	1.08
	Tuesday	1.09	1.07	1.04	1.04	1.04	1.05	1.04	1.05
	Wednesday	1.11	1.07	1.05	1.04	1.05	1.05	1.05	1.06
	Thursday	1.12	1.07	1.04	1.03	1.05	1.06	1.05	1.07
	Friday	1.11	1.07	1.05	1.04	1.04	1.05	1.04	1.05
	Saturday	1.18	1.08	1.07	1.06	1.08	1.09	1.07	1.10
	Sunday	1.31	1.17	1.13	1.14	1.15	1.13	1.16	1.19
December	Monday	0.95	0.91	0.92	0.91	0.92	0.93	0.92	0.92
	Tuesday	1.00	0.96	0.98	0.97	0.99	0.99	1.00	0.99
	Wednesday	1.00	0.97	0.98	0.99	0.99	1.00	1.01	1.00
	Thursday	0.97	0.95	0.96	0.97	0.98	0.98	1.00	0.97
	Friday	0.90	0.90	0.93	0.95	0.96	0.94	0.96	0.94
	Saturday	0.78	0.82	0.87	0.87	0.86	0.87	0.88	0.83
	Sunday	0.66	0.72	0.79	0.77	0.77	0.78	0.77	0.70

Table 3-G includes Monthly Variation



TABLE 3-H: ANNUAL TOTAL TRANSACTIONS BY TOLL PLAZA

Plaza	Plaza Code*	2015	2016	Percentage Change
20 Buckley Road	R	2,598,957	2,602,642	0.1%
21 Waukegan	M	27,263,657	28,682,181	5.2%
22 Illinois Route 60	R	3,934,287	3,878,568	-1.4%
23 Half Day Road	R	3,905,700	4,112,064	5.3%
24 Edens Spur	M	20,518,292	21,070,450	2.7%
26 Lake-Cook Road	R	6,355,590	6,524,979	2.7%
27 Willow Road	R	6,297,538	6,449,806	2.4%
28 Golf Road	R	6,526,047	6,668,290	2.2%
29 Touhy Avenue	M1	34,120,325	35,490,650	4.0%
30 Balmoral Avenue	E	3,632,923	4,112,392	13.2%
31 O'Hare West	R1	7,957,356	9,130,001	14.7%
32 O'Hare East	R1	6,426,140	6,583,519	2.4%
33 Irving Park Road	M1	39,420,373	40,361,344	2.4%
34 Willow Springs Road	R	2,367,198	2,405,044	1.6%
35 Cermak Road	M	54,566,407	56,607,378	3.7%
36 82nd Street	M1	28,896,298	30,519,564	5.6%
37 I-55	R	23,441,293	24,010,145	2.4%
38 95th Street	R	5,708,253	6,069,055	6.3%
39 83rd Street	M1	28,142,875	29,741,633	5.7%
40 159th Street	R	2,603,538	2,424,915	-6.9%
41 163rd Street	M	37,397,214	39,188,780	4.8%
42 I-57	E	9,671,082	12,249,302	26.7%
43 I-80 Westbound	A1	12,725,287	13,091,530	2.9%
45 I-80 Eastbound	A1	12,209,500	12,306,884	0.8%
47 Halsted Street	R	7,845,352	8,102,879	3.3%
Tri-State Total		394,531,482	412,383,995	4.5%

* M=Mainline / R=Ramp / A=Attended Ramp Plaza / E=Electronic Toll Collection Only Ramp
 1=Toll Collected in One Direction Only



TABLE 3-I: AVERAGE DAILY TRAFFIC DATA

Year	Average Daily Total			Average Trip
	Vehicles	Vehicle Miles	Transactions	Length (Miles)
1959	42,944	1,074,421	87,977	25.02
1960	53,665	1,423,119	114,591	26.52
1961	63,040	1,508,414	113,413	23.93
1962	79,567	1,716,653	149,996	21.57
1963	81,865	1,538,064	135,872	18.79
1964	83,177	1,576,375	140,729	18.95
1965	96,141	1,791,966	161,958	18.64
1966	104,898	2,070,944	189,068	19.74
1967	113,248	2,264,510	211,941	20.00
1968	124,197	2,499,952	255,161	20.13
1969	145,335	2,795,118	285,279	19.23
1970	150,204	2,993,741	305,965	19.93
1971	165,910	3,324,444	340,539	20.04
1972	177,740	3,435,183	352,056	19.33
1973	196,462	3,684,032	386,527	18.75
1974	206,074	3,814,440	404,858	18.51
1975	212,313	3,815,435	407,611	17.97
1976	234,136	4,147,527	442,435	17.71
1977	252,032	4,472,743	475,766	17.75
1978	268,655	4,748,560	504,534	17.68
1979	274,714	4,870,270	520,258	17.73
1980	264,698	4,804,154	508,555	18.15
1981	279,965	4,905,922	522,890	17.52
1982	281,782	4,818,745	519,152	17.10
1983	291,652	5,001,519	532,111	17.15
1984	310,008	5,493,171	583,129	17.72
1985	327,277	5,660,998	603,292	17.30
1986	348,651	6,227,866	654,517	17.86
1987	367,191	6,233,335	685,226	16.98
1988	396,711	7,132,315	749,395	17.98
1989	410,352	7,364,825	771,395	17.95
1990	425,089	7,501,631	779,065	17.65
1991	478,355	7,607,215	797,157	15.90
1992	494,963	7,283,706	781,630	14.72
1993	499,598	7,205,338	782,631	14.42
1994	491,071	8,254,734	859,181	16.81
1995	520,320	8,814,694	916,329	16.94
1996	540,460	9,090,414	945,831	16.82
1997	562,300	9,257,833	971,481	16.46
1998	577,930	9,408,676	975,821	16.28
1999	576,220	9,404,524	893,630	16.32
2000	590,900	9,632,552	916,723	16.30
2001	601,820	9,775,171	933,313	16.24
2002	615,200	10,263,261	965,408	16.68
2003	626,950	10,515,023	989,952	16.77
2004	634,390	10,611,992	1,003,291	16.73
2005	594,220	9,982,878	936,432	16.80
2006	537,400	9,956,325	927,615	18.53
2007	563,600	10,132,520	964,388	17.98
2008	581,370	9,101,117	894,275	15.65
2009	578,140	8,992,194	886,512	15.55
2010	581,150	9,979,253	955,841	17.17
2011	595,800	10,128,377	982,468	17.00
2012	582,330	9,752,805	940,793	16.75
2013	596,490	10,242,864	973,802	17.17
2014	612,520	10,551,115	1,006,738	17.23
2015	638,240	11,335,773	1,080,908	17.76
2016	662,790	11,684,828	1,126,732	17.63

Average Daily Vehicles and Average Trip Length have been restated for 2010-2015.



FIGURE 3-A

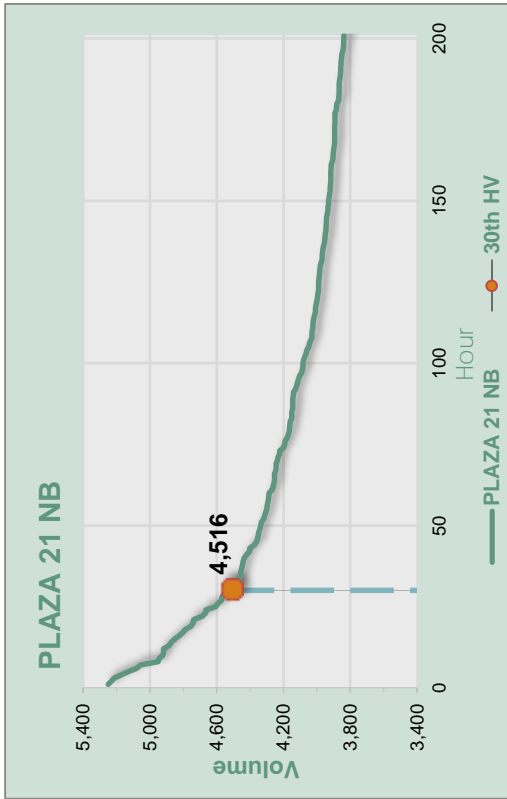

FIGURE 3-B

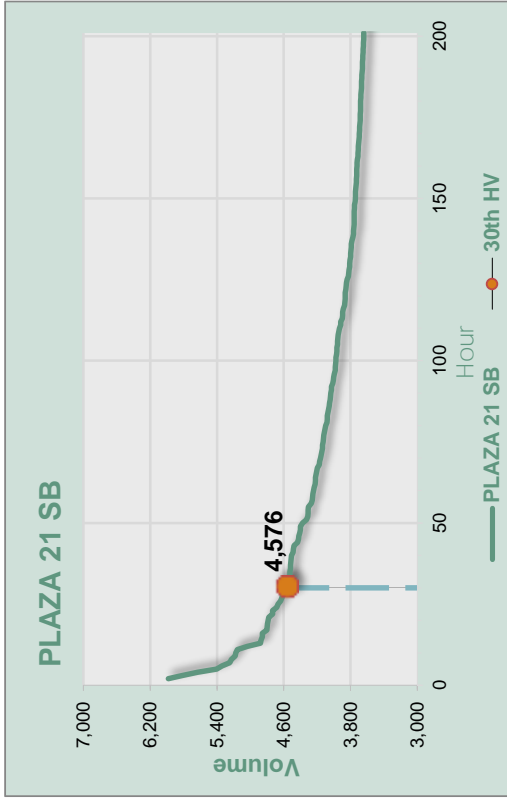
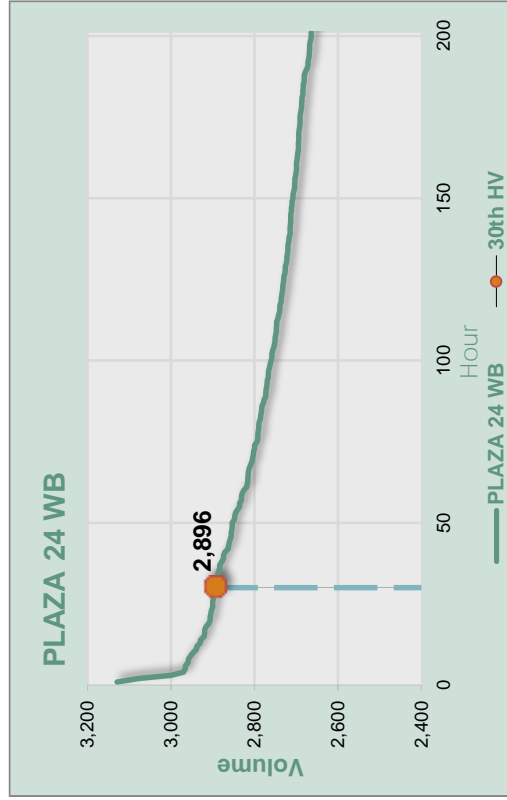

FIGURE 3-C



FIGURE 3-D



MAINLINE PLAZA HIGHEST HOURLY VOLUME



FIGURE 3-F

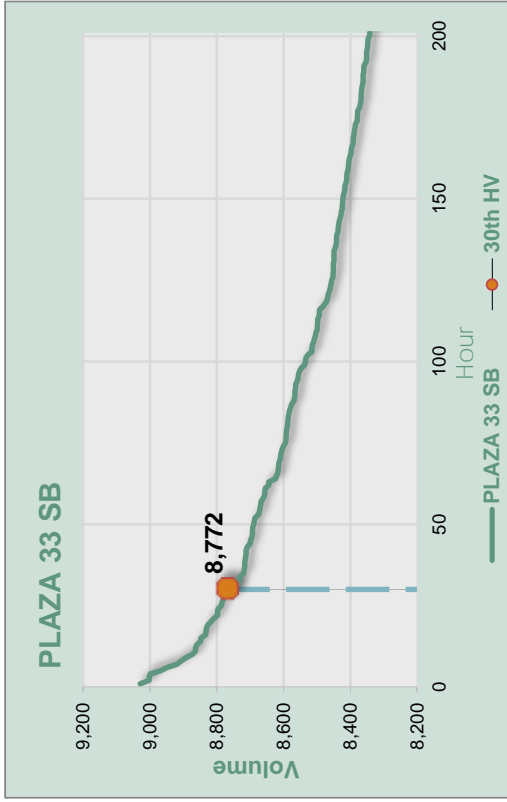

FIGURE 3-H

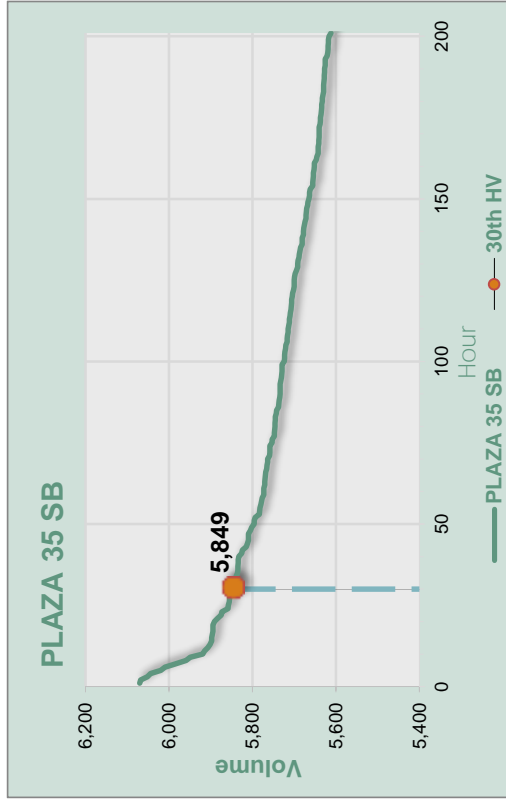

FIGURE 3-E

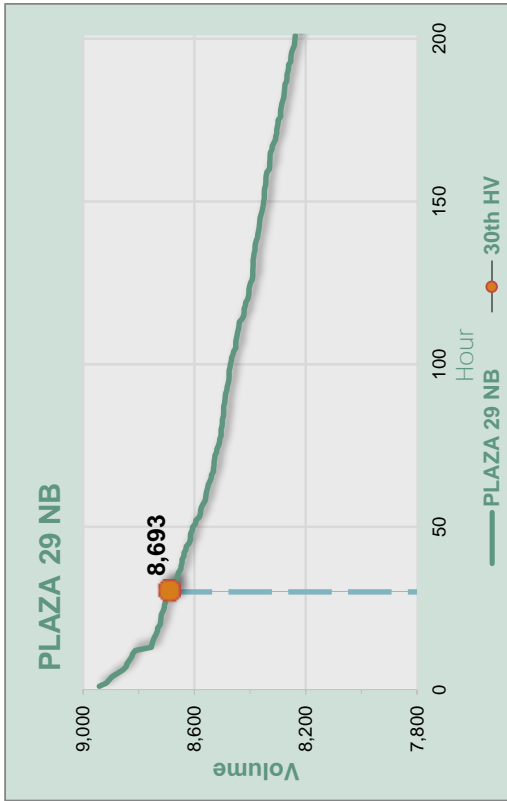
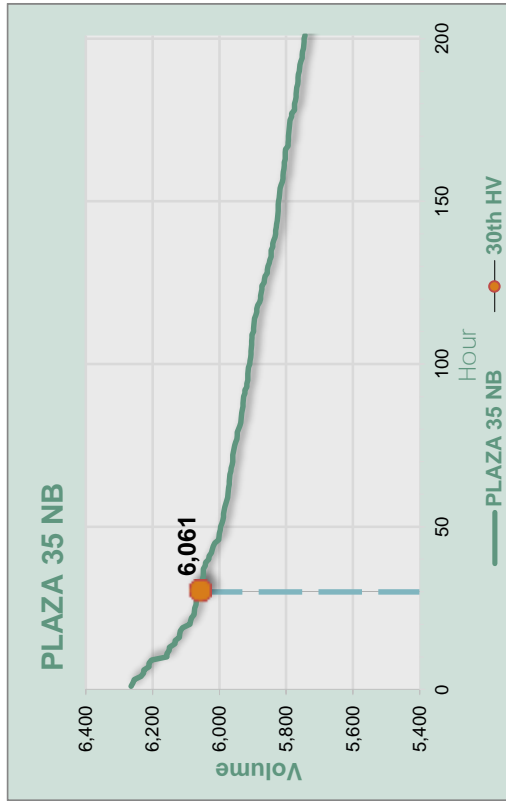

FIGURE 3-G



MAINLINE PLAZA HIGHEST HOURLY VOLUME



FIGURE 3-J

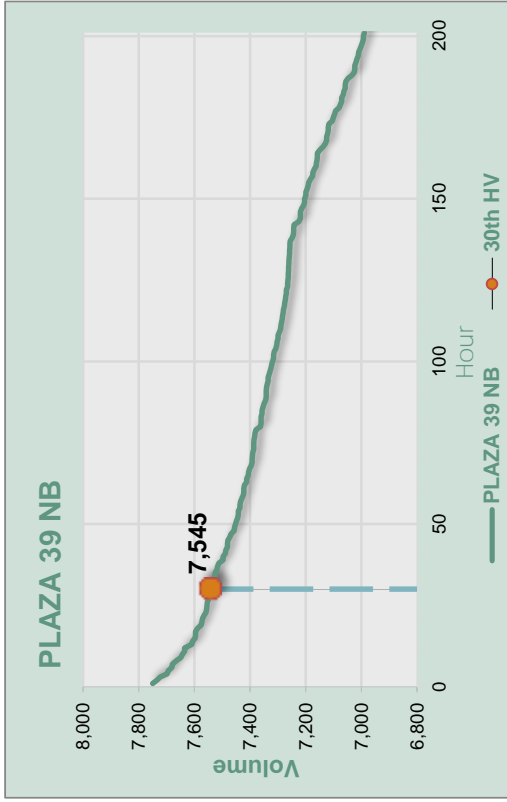

FIGURE 3-I

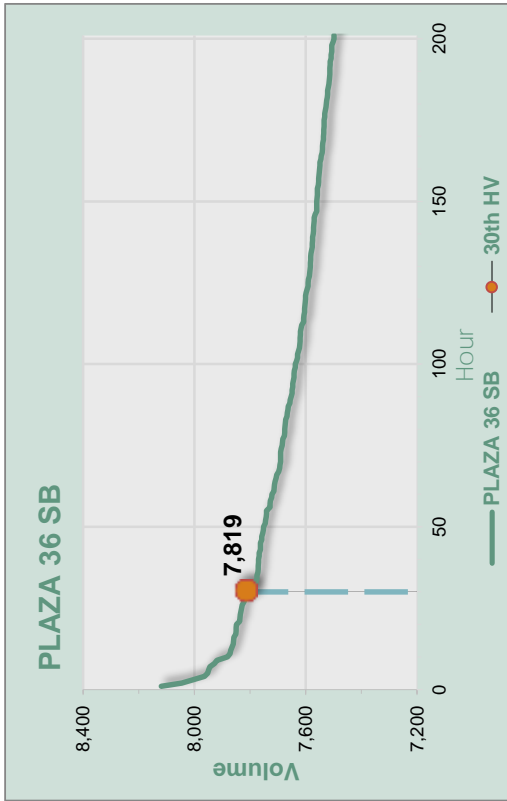

FIGURE 3-L

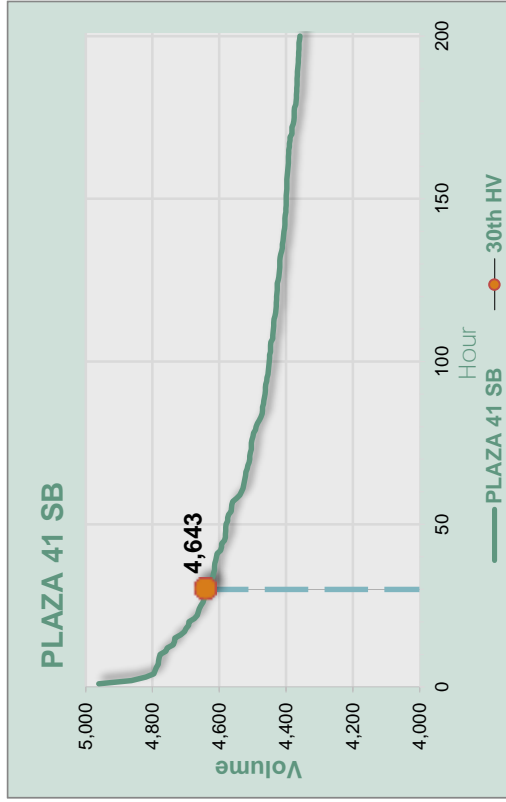
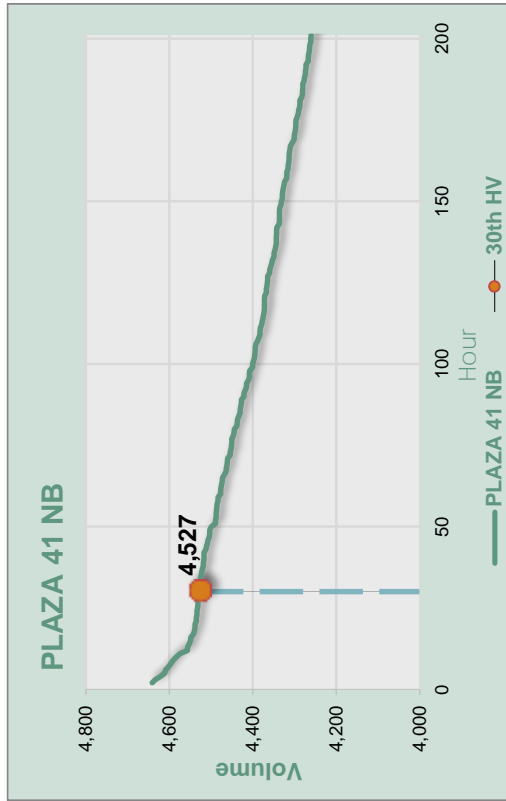

FIGURE 3-K



MAINLINE PLAZA HIGHEST HOURLY VOLUME



FIGURE 3-M

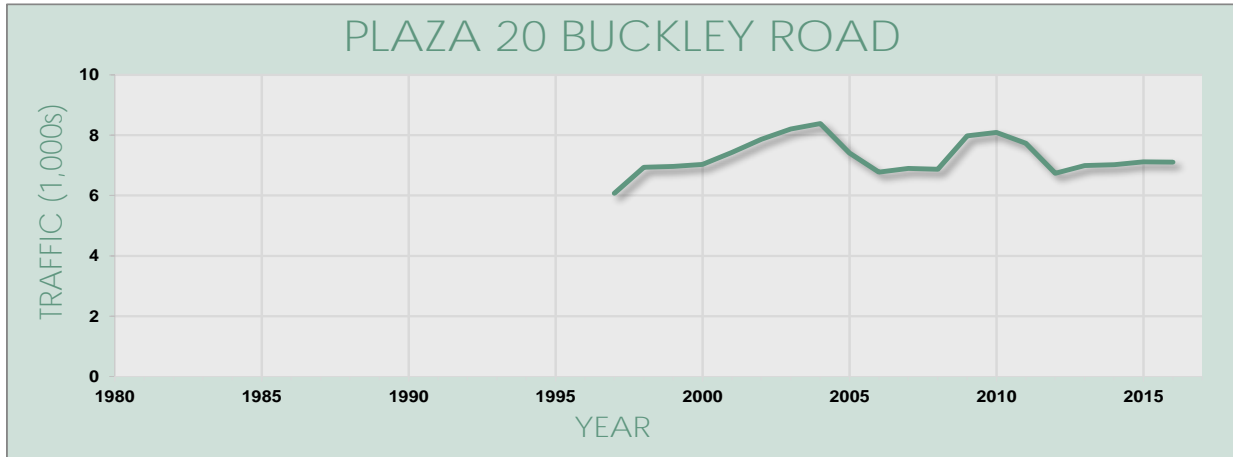

FIGURE 3-N

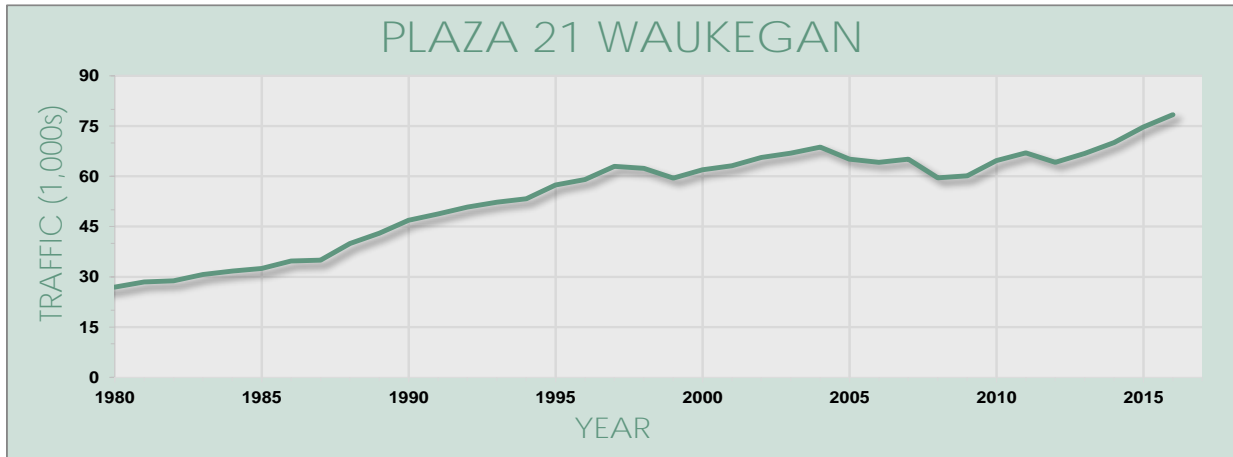
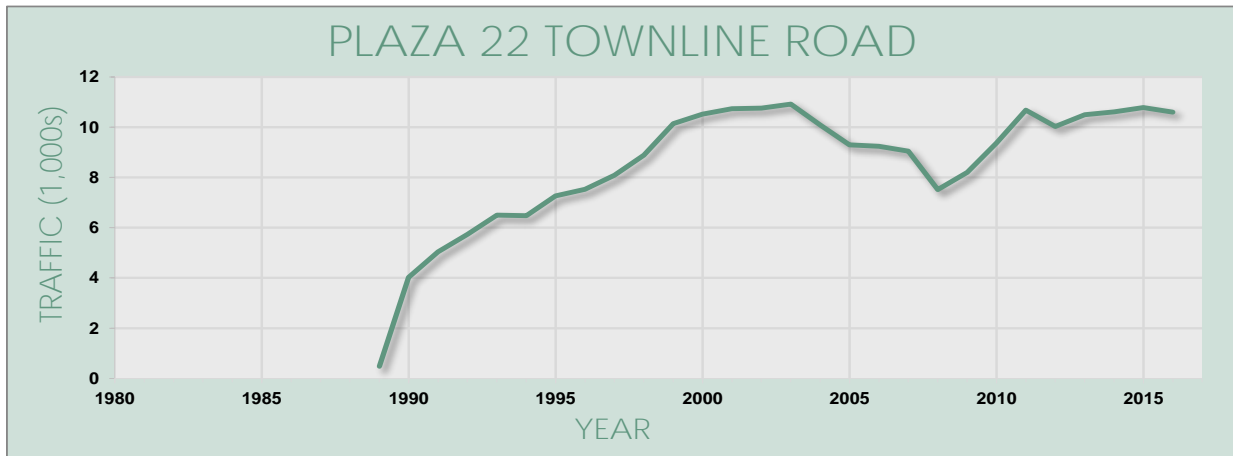

FIGURE 3-O



AVERAGE DAILY TRAFFIC TRENDS



FIGURE 3-P

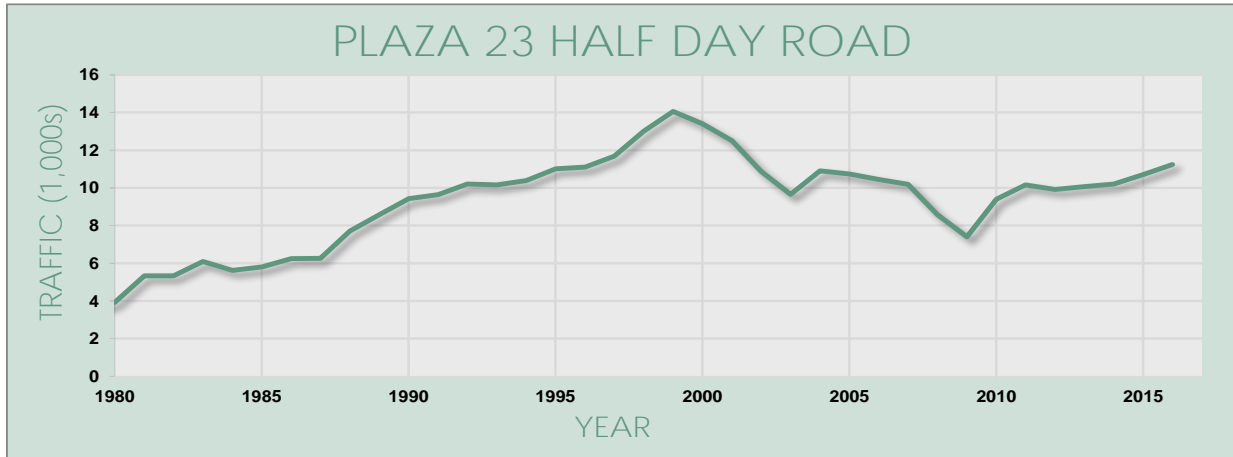

FIGURE 3-Q

Plaza 24 opened in 1999 due to Plaza 25 removal.

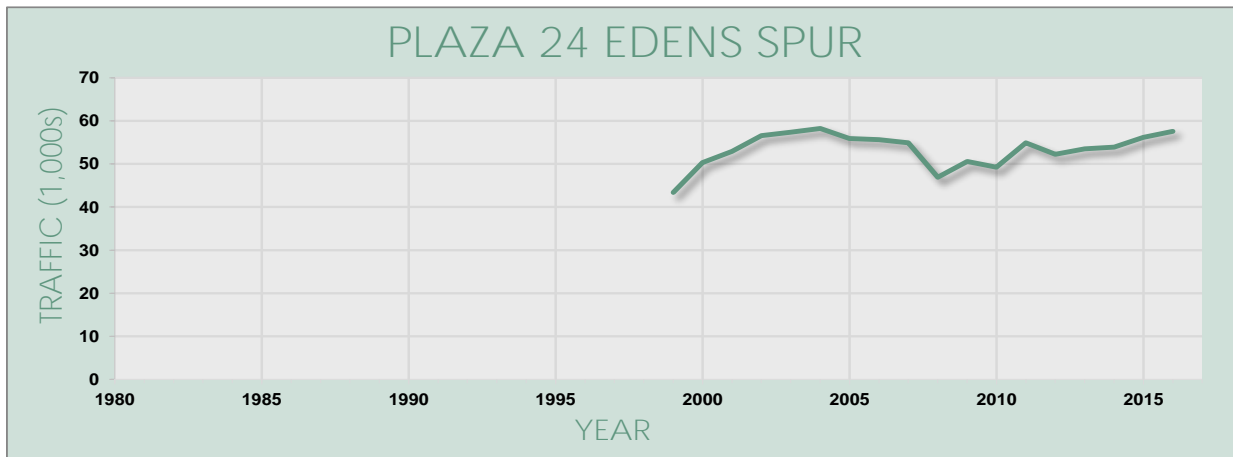
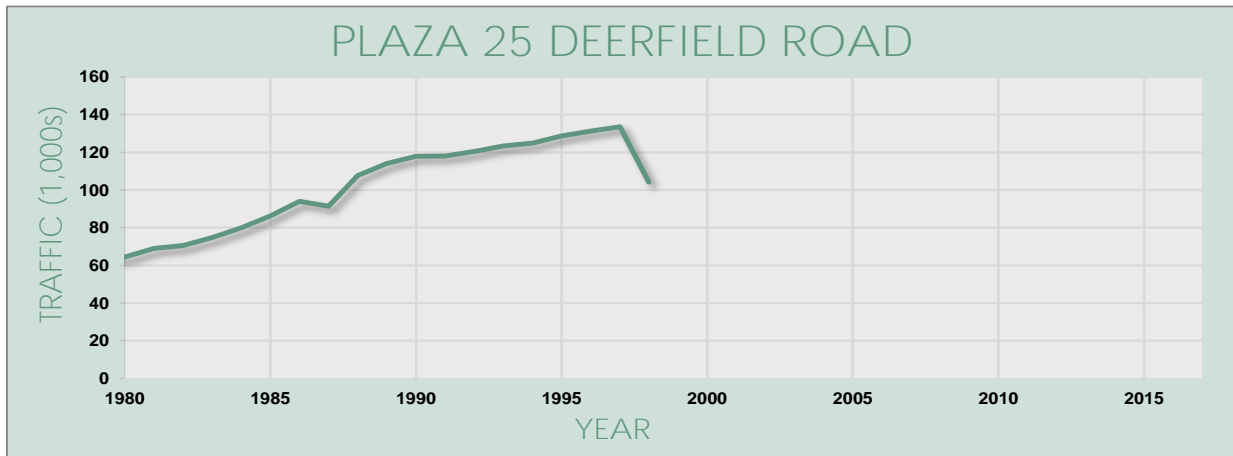

FIGURE 3-R

Plaza 25 removed in 1998.



AVERAGE DAILY TRAFFIC TRENDS



FIGURE 3-S Toll collection at Plaza 26 was moved from ramps to/from the south to ramps to/from the north due to Plaza 25 removal.

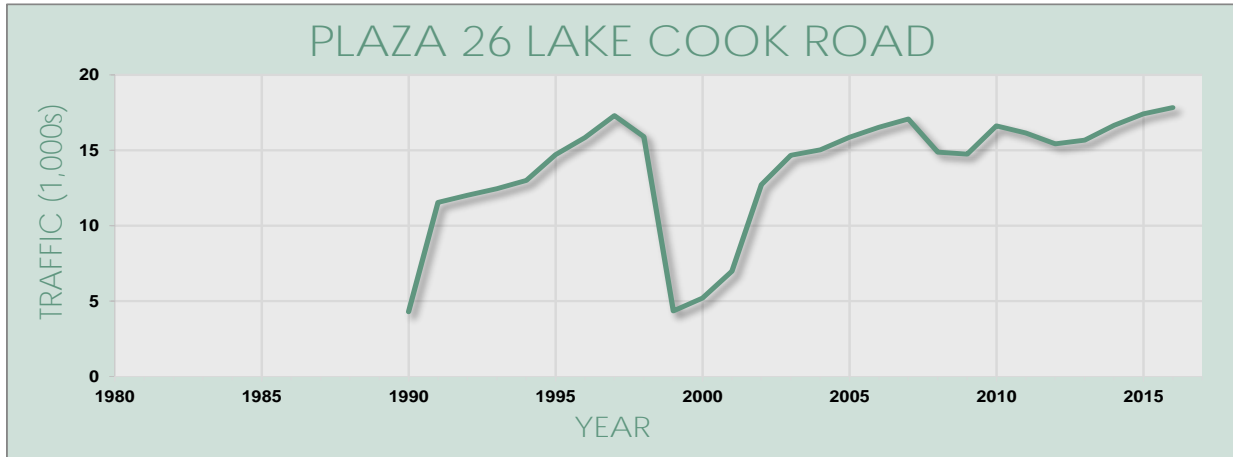

FIGURE 3-T Toll collection at Plaza 27 was moved from ramps to/from the south to ramps to/from the north due to Plaza 25 removal.

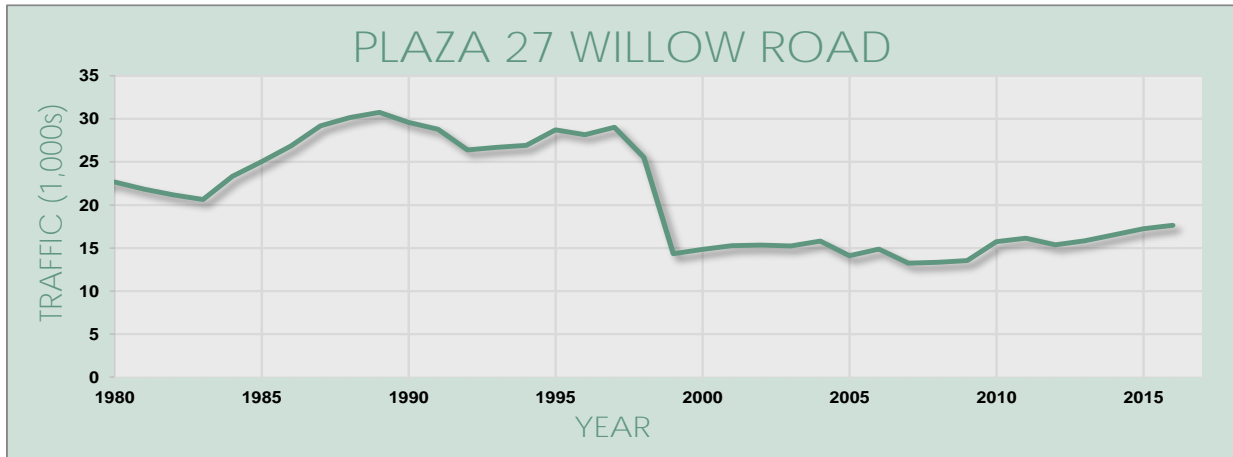
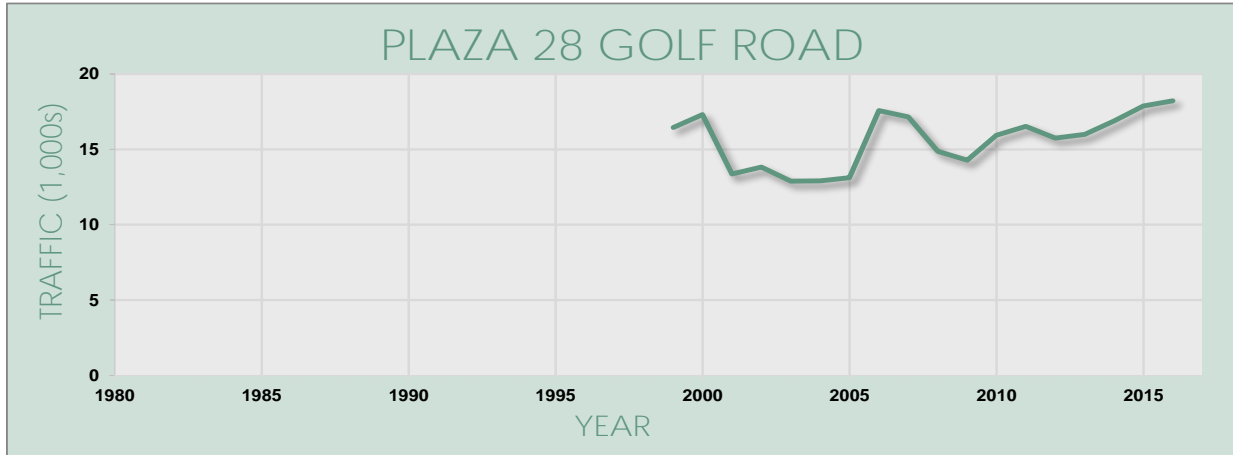

FIGURE 3-U Plaza 28 opened in 1998 due to Plaza 25 removal.



AVERAGE DAILY TRAFFIC TRENDS



FIGURE 3-V

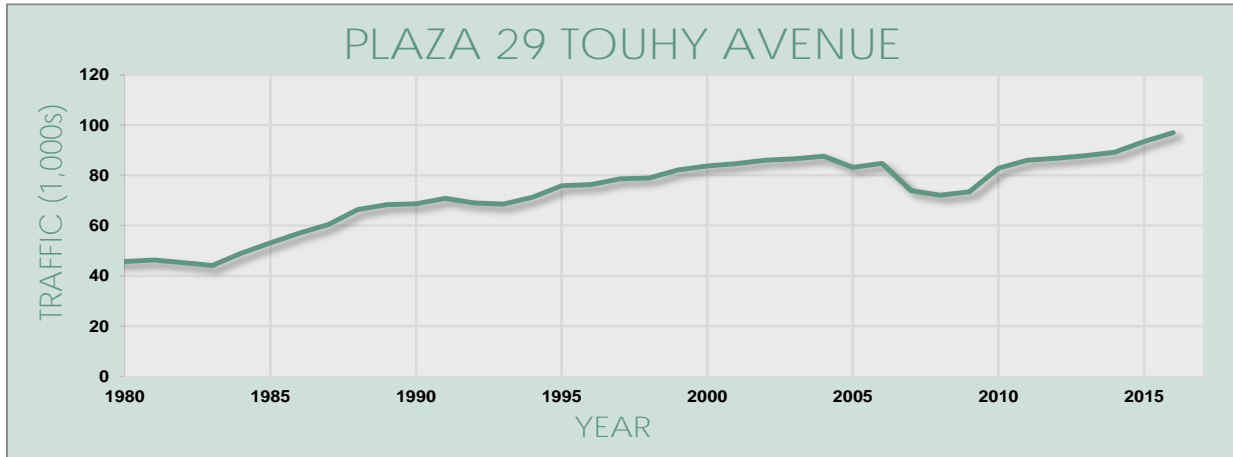

FIGURE 3-W

Plaza 30 opened in 2011.

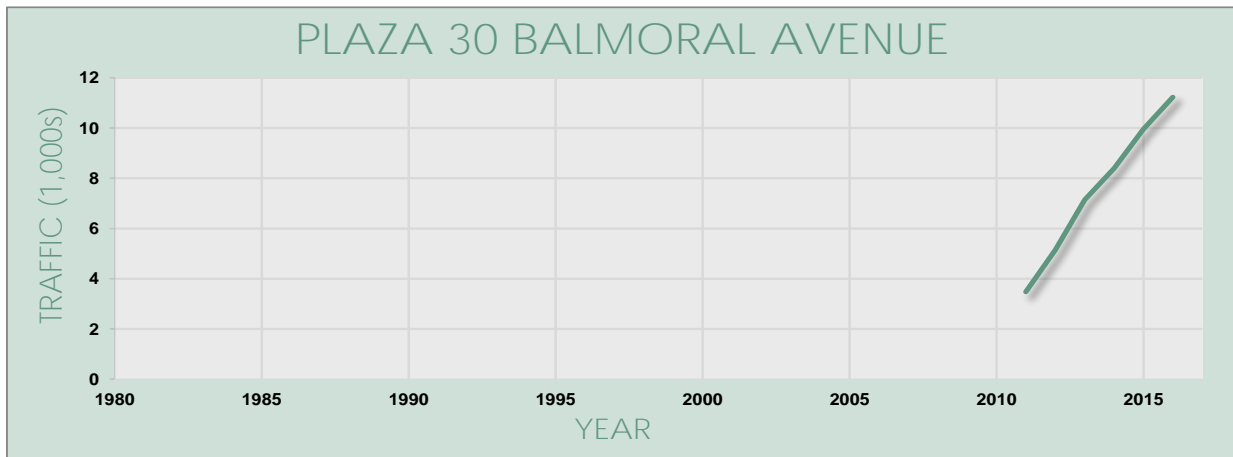
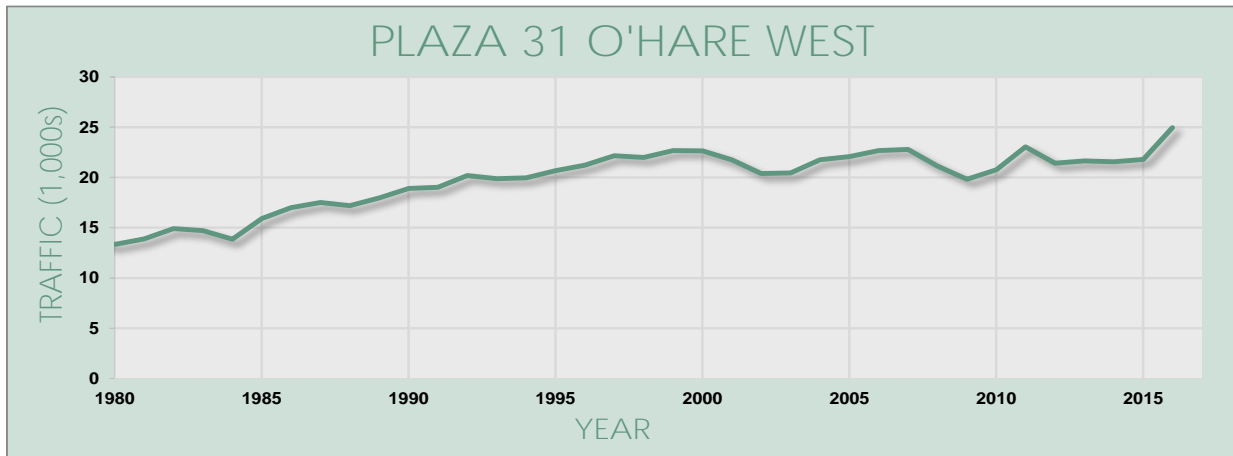

FIGURE 3-X



AVERAGE DAILY TRAFFIC TRENDS



FIGURE 3-Y

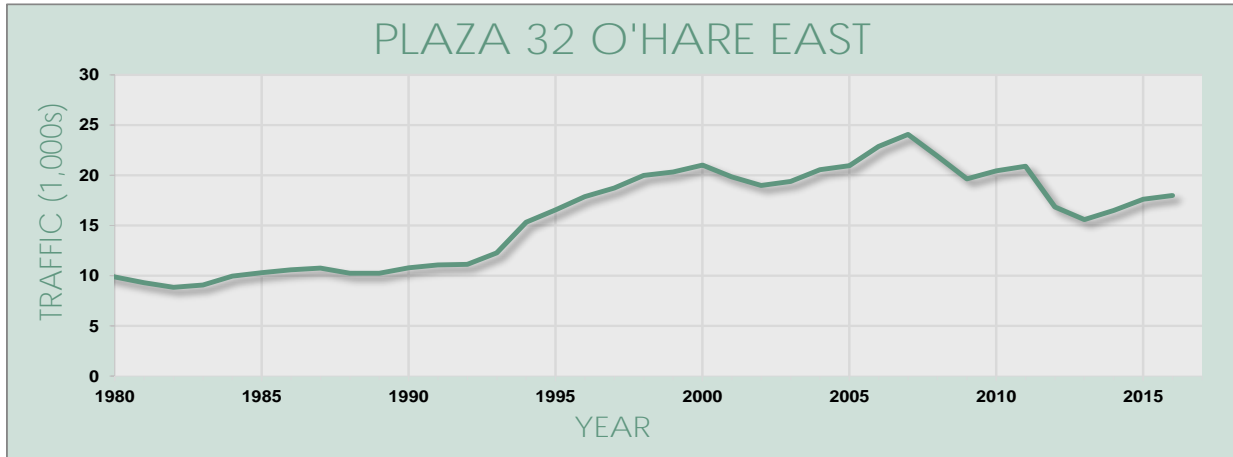

FIGURE 3-Z

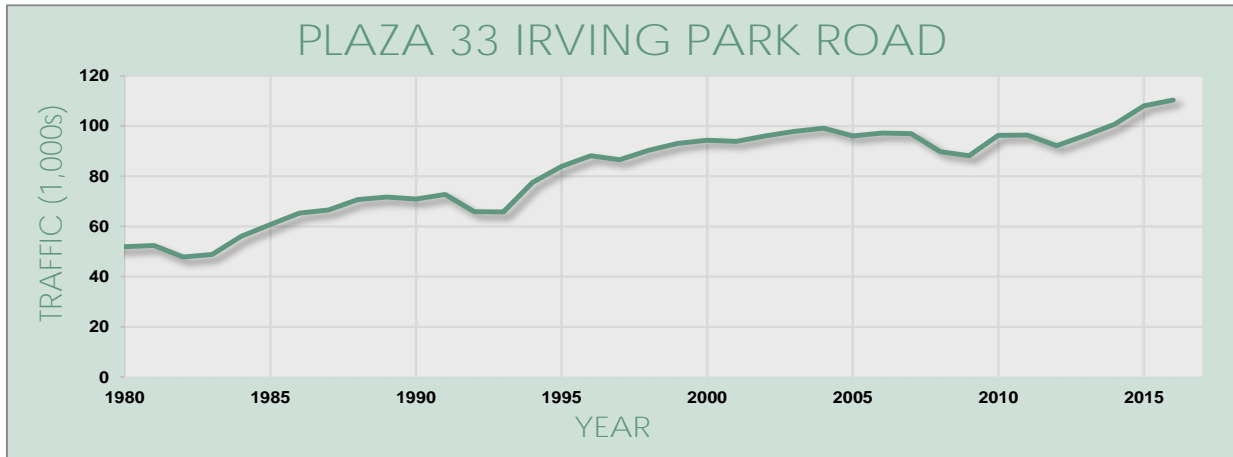
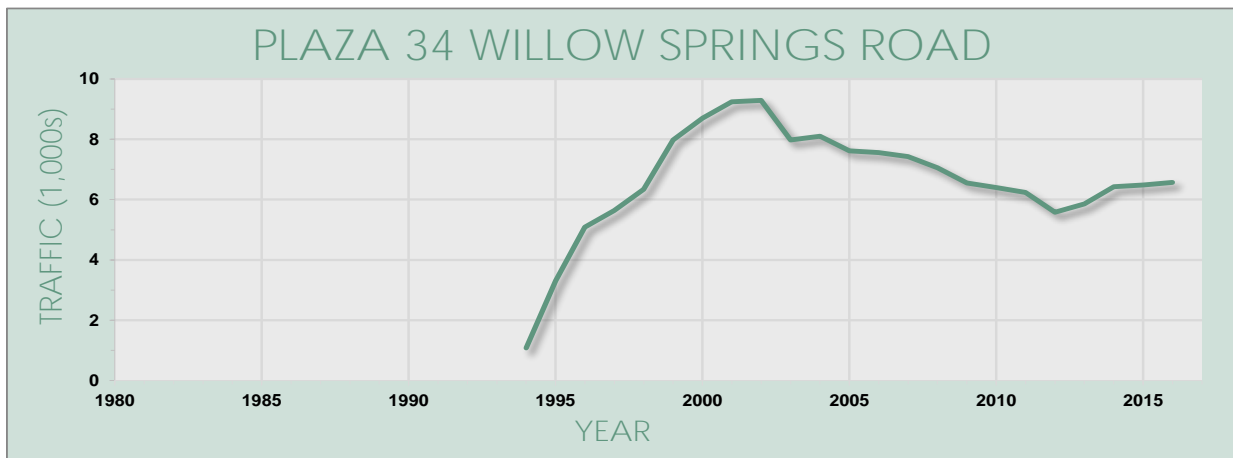

FIGURE 3-AA

Plaza 34 opened in 1994 due to the replacement of southbound Plaza 39 with Plaza 36.



AVERAGE DAILY TRAFFIC TRENDS



FIGURE 3-AB

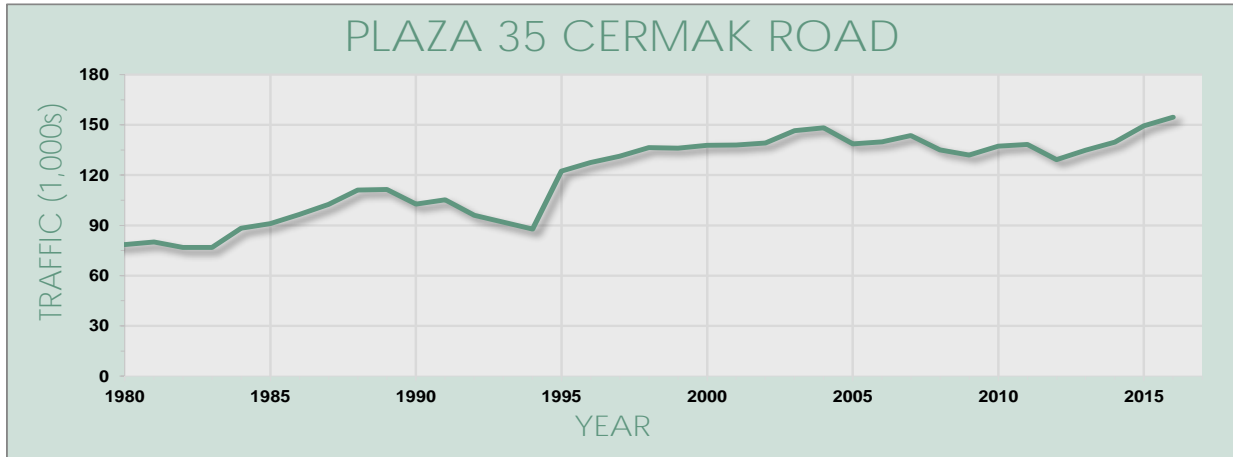

FIGURE 3-AC

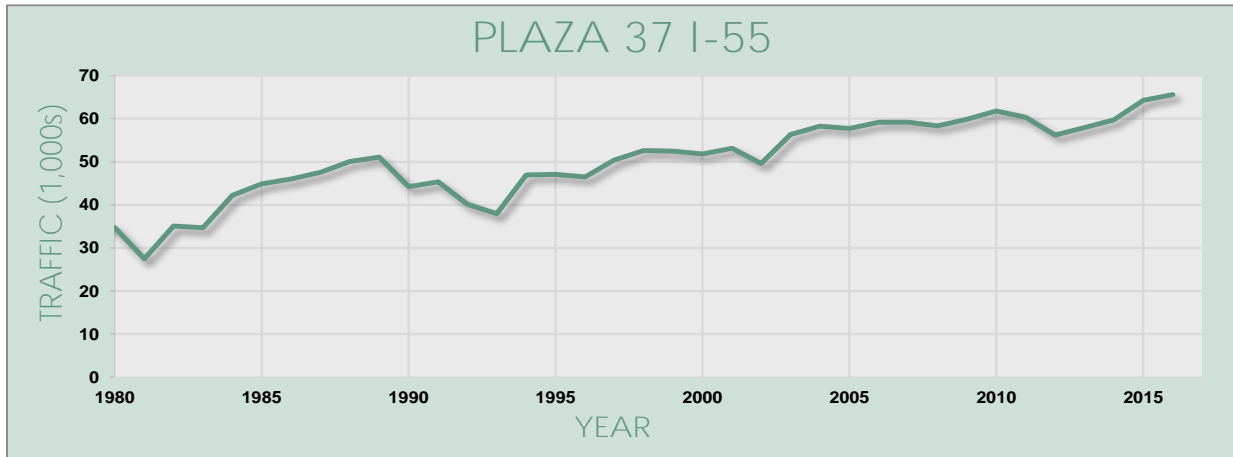
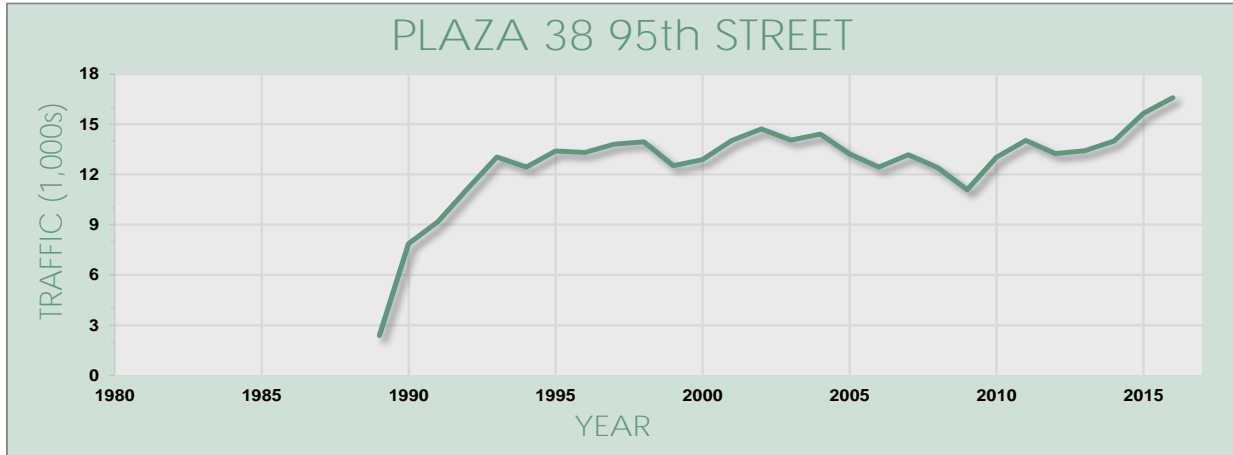

FIGURE 3-AD



AVERAGE DAILY TRAFFIC TRENDS



FIGURE 3-AE

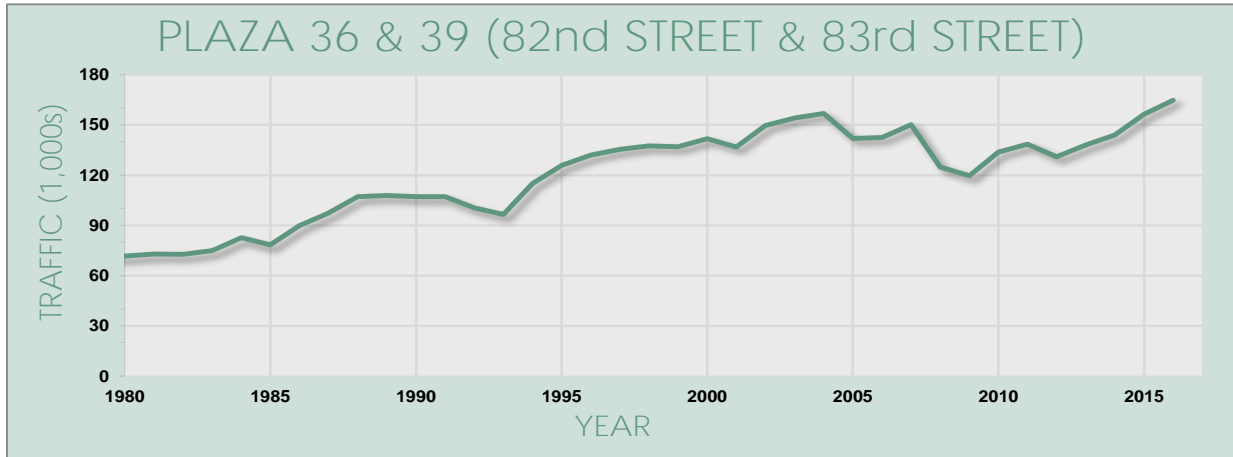

FIGURE 3-AF

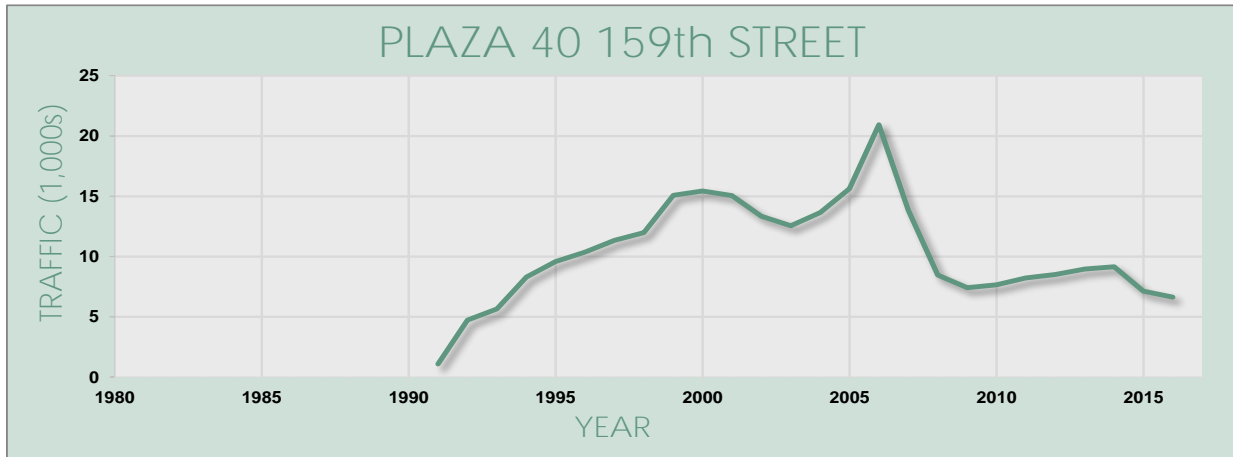
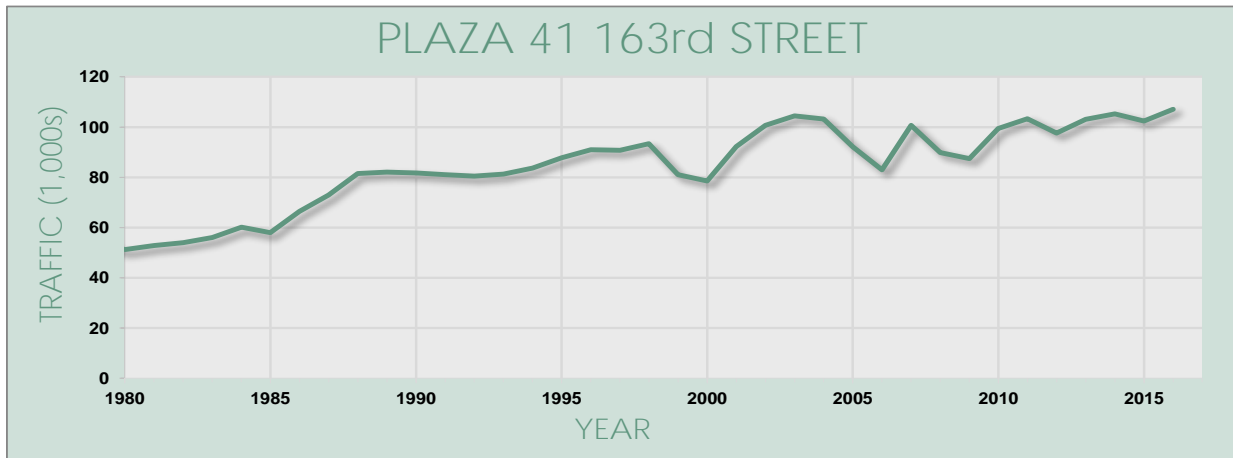

FIGURE 3-AG



AVERAGE DAILY TRAFFIC TRENDS



FIGURE 3-AH

Plaza 42 opened in 2014.

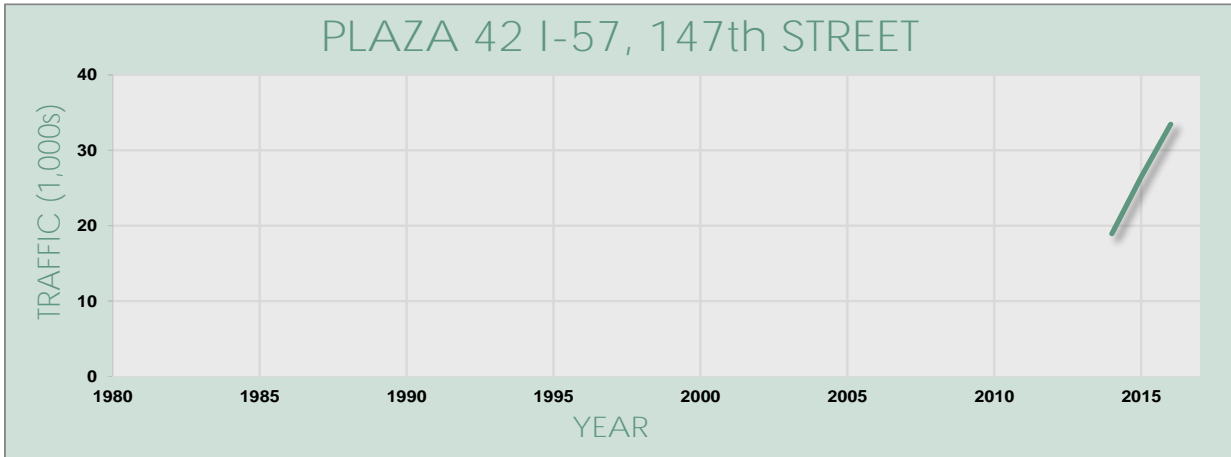

FIGURE 3-AI

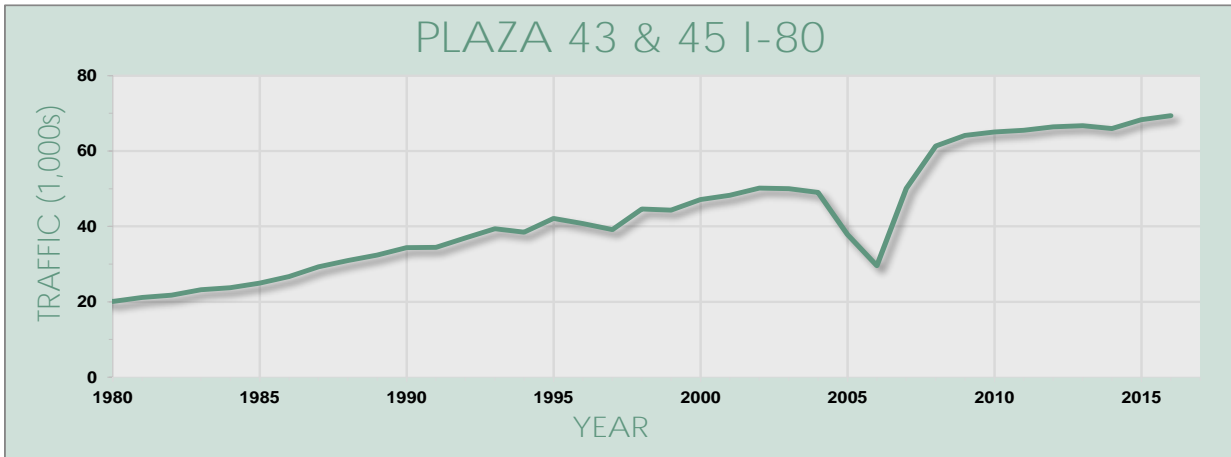
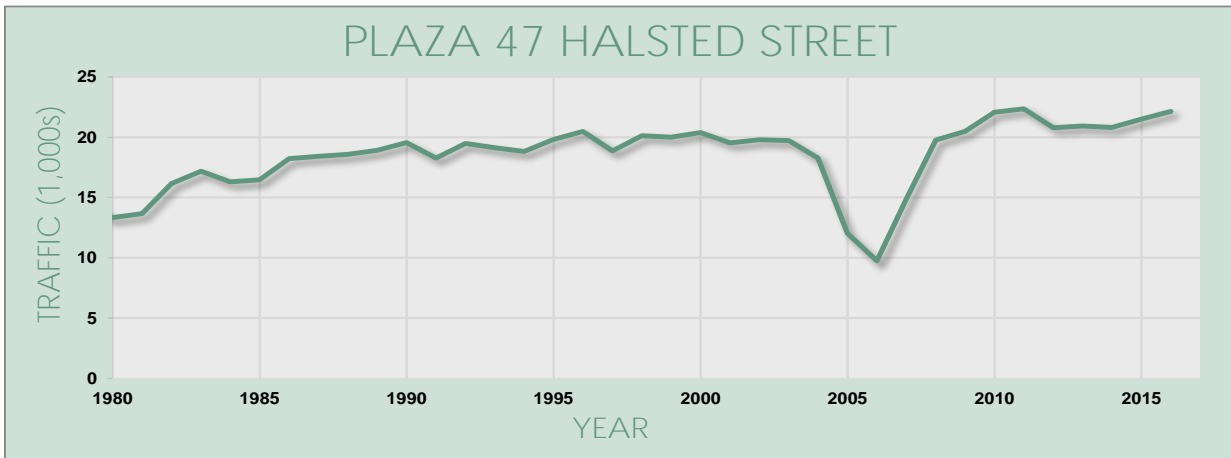

FIGURE 3-AJ



AVERAGE DAILY TRAFFIC TRENDS



AVERAGE WEEKDAY SPEED DISTRIBUTIONS, NORTHERN SECTION

FIGURE 3-AK

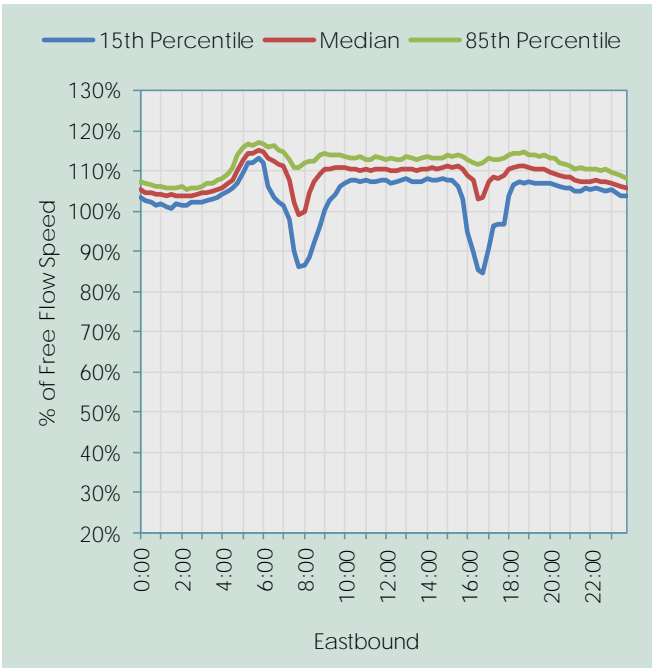
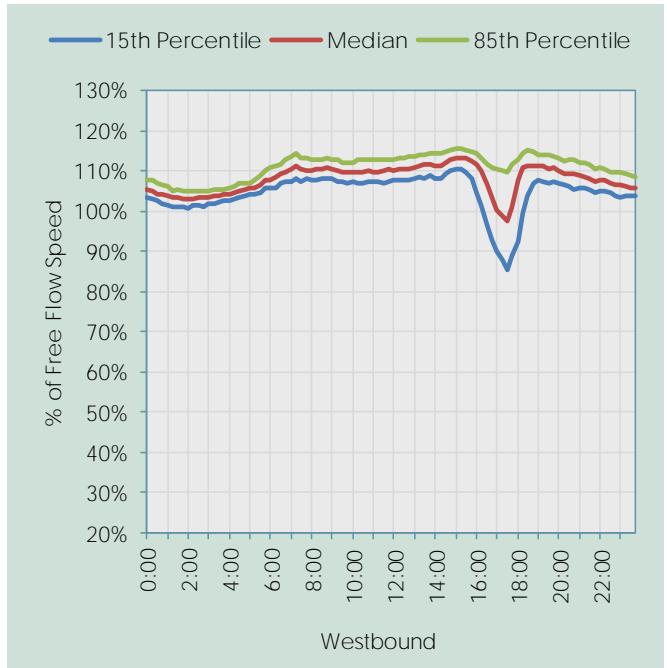

FIGURE 3-AL



AVERAGE WEEKDAY SPEED DISTRIBUTIONS, NORTH CENTRAL SECTION

FIGURE 3-AM

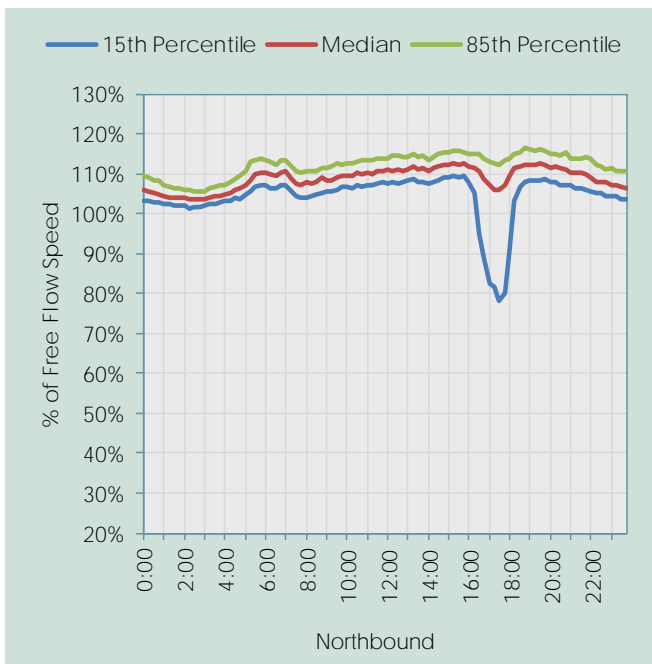
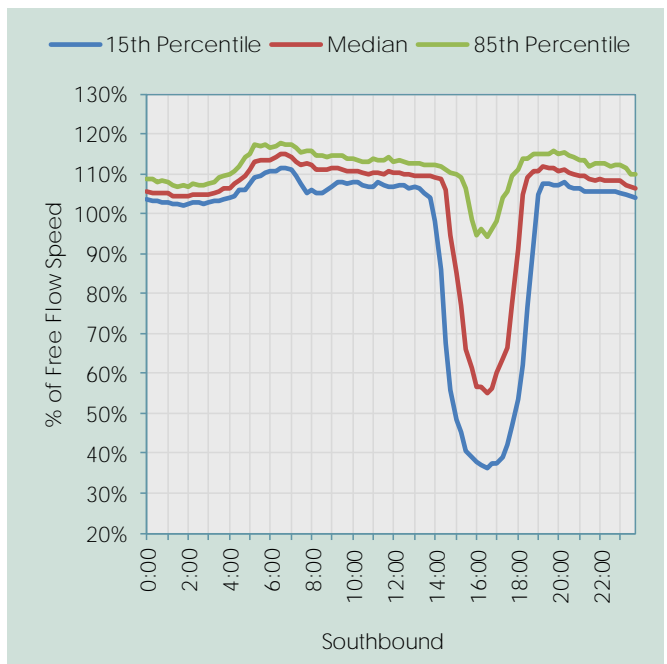

FIGURE 3-AN





AVERAGE WEEKDAY SPEED DISTRIBUTIONS, SOUTH CENTRAL SECTION

FIGURE 3-AO

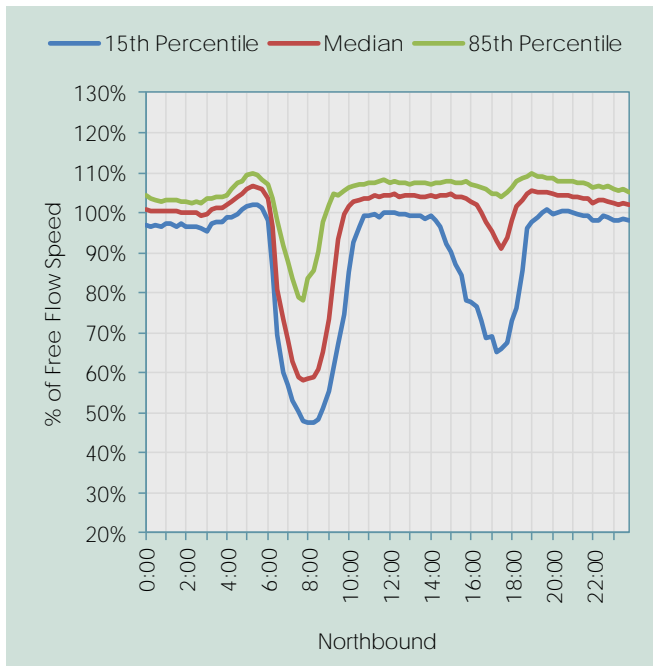
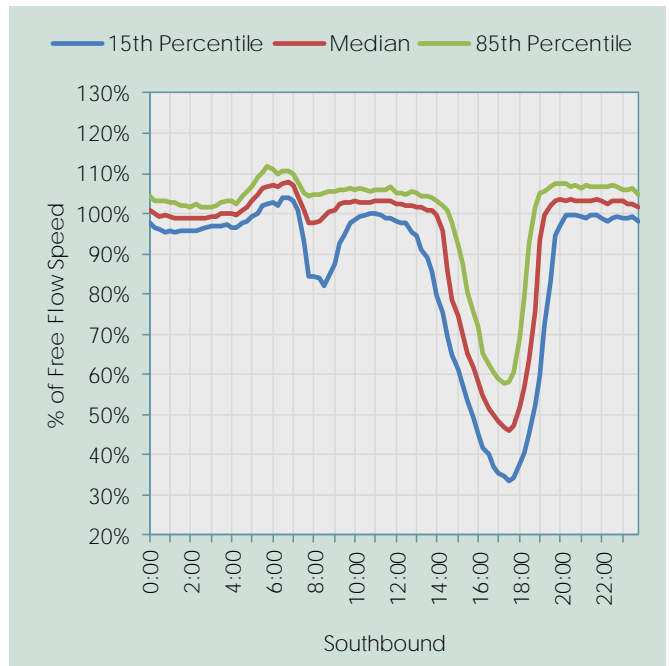

FIGURE 3-AP



AVERAGE WEEKDAY SPEED DISTRIBUTIONS, SOUTHERN SECTION

FIGURE 3-AQ

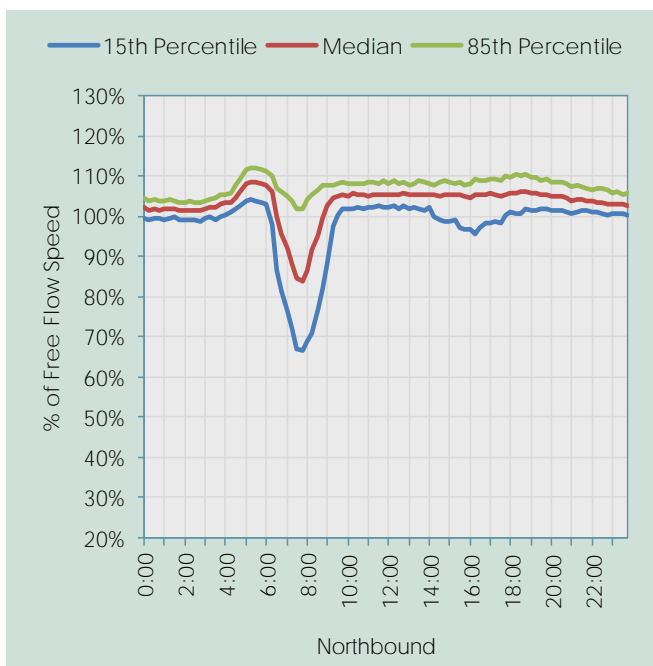
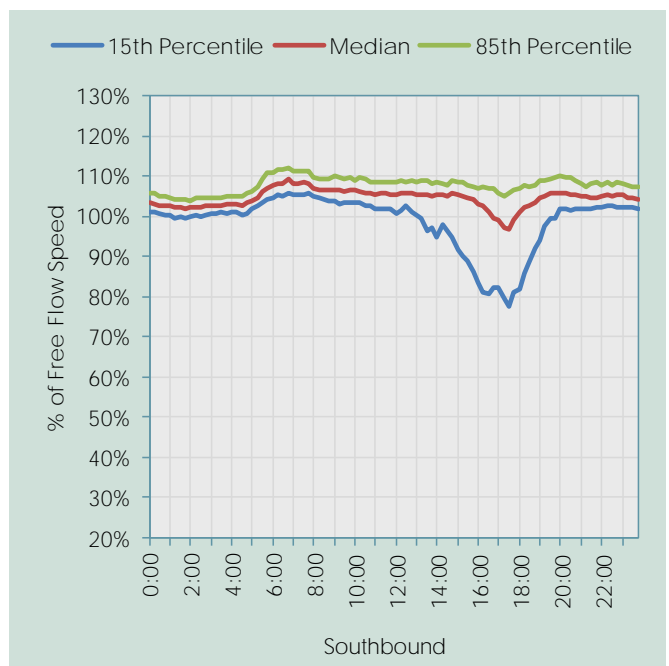

FIGURE 3-AR





Quarter	Range	Average Speed (mph)		Average Travel Time Index		Planning Time Index		Total Delay (veh-hrs / 1000 VMT)		Average Daily Delay (veh-hrs)		Percent Congested Travel	
		AM	PM	AM	PM	AM	PM	AM	PM	AM	PM	AM	PM
1	January -March	65	64	0.92	0.94	1.01	1.02	0.2	0.5	121	310	6	8
2	April-June	65	62	0.93	0.97	0.99	1.01	0.4	1.0	258	702	9	17
3	July-September	65	61	0.93	0.99	0.99	1.13	0.4	1.4	282	964	10	20
4	October-December	63	63	0.95	0.96	1.00	1.15	0.8	0.8	475	519	9	15
Total	2016 Entire Year	64	62	0.93	0.96	1.00	1.08	0.5	0.9	284	624	8	15

Data source: INRIX. Roadway performance measures sections and terms are defined on pages 1-4 and 1-5.

FIGURE 3-AS: ROADWAY PERFORMANCE MEASURES—NORTHERN SECTION

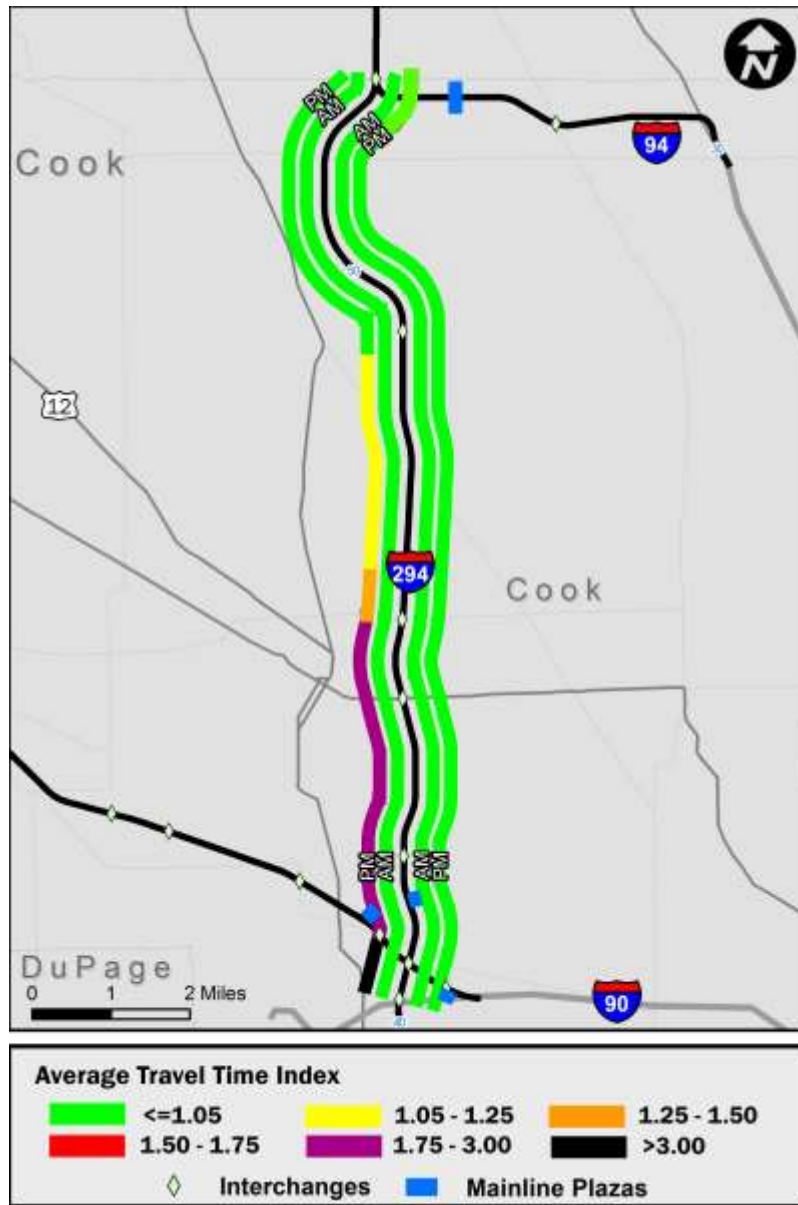

Quarter	Range	Average Speed (mph)		Average Travel Time Index		Planning Time Index		Total Delay (veh-hrs / 1000 VMT)		Average Daily Delay (veh-hrs)		Percent Congested Travel	
		AM	PM	AM	PM	AM	PM	AM	PM	AM	PM	AM	PM
1	January -March	65	55	0.92	1.09	0.98	1.41	0.2	2.9	75	1,067	6	15
2	April-June	66	41	0.91	1.46	0.95	2.00	0.1	8.9	58	3,457	5	30
3	July-September	64	46	0.93	1.30	1.01	1.73	0.5	6.5	186	2,487	7	24
4	October-December	65	46	0.92	1.31	1.00	1.85	0.2	6.5	86	2,418	6	24
Total	2016 Entire Year	65	47	0.92	1.29	0.98	1.75	0.3	6.2	101	2,357	6	23

Data source: INRIX. Roadway performance measures sections and terms are defined on pages 1-4 and 1-5.

FIGURE 3-AT: ROADWAY PERFORMANCE MEASURES—NORTH CENTRAL SECTION

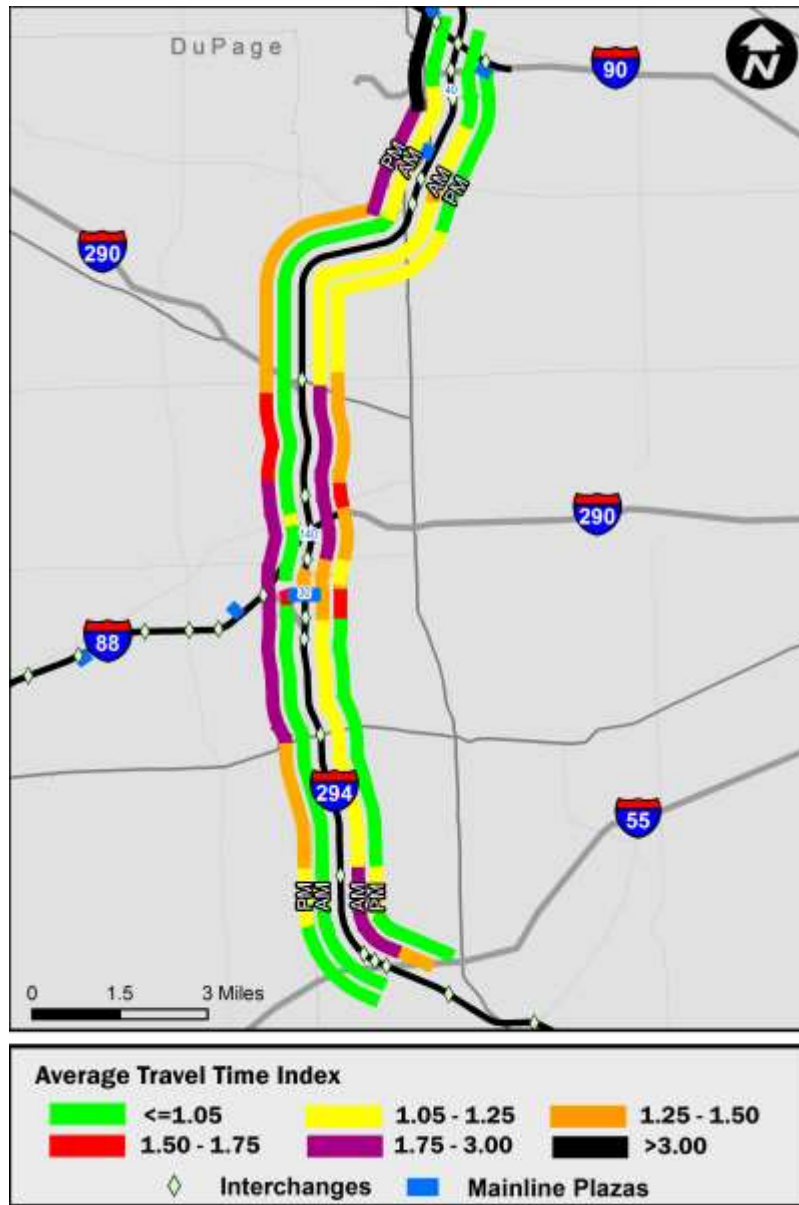

Quarter	Range	Average Speed (mph)		Average Travel Time Index		Planning Time Index		Total Delay (veh-hrs / 1000 VMT)		Average Daily Delay (veh-hrs)		Percent Congested Travel	
		AM	PM	AM	PM	AM	PM	AM	PM	AM	PM	AM	PM
1	January -March	53	46	1.13	1.30	1.42	1.88	2.7	5.5	1,662	3,288	42	51
2	April-June	47	38	1.29	1.60	1.44	2.09	5.3	10.3	3,443	6,410	56	67
3	July-September	47	38	1.28	1.56	1.62	2.25	5.2	9.7	3,267	5,946	56	67
4	October-December	50	40	1.21	1.50	1.44	2.12	4.0	8.6	2,458	5,179	52	63
Total	2016 Entire Year	49	41	1.23	1.49	1.48	2.09	4.3	8.6	2,708	5,206	51	62

Data source: INRIX. Roadway performance measures sections and terms are defined on pages 1-4 and 1-5.

FIGURE 3-AU: ROADWAY PERFORMANCE MEASURES—SOUTH CENTRAL SECTION

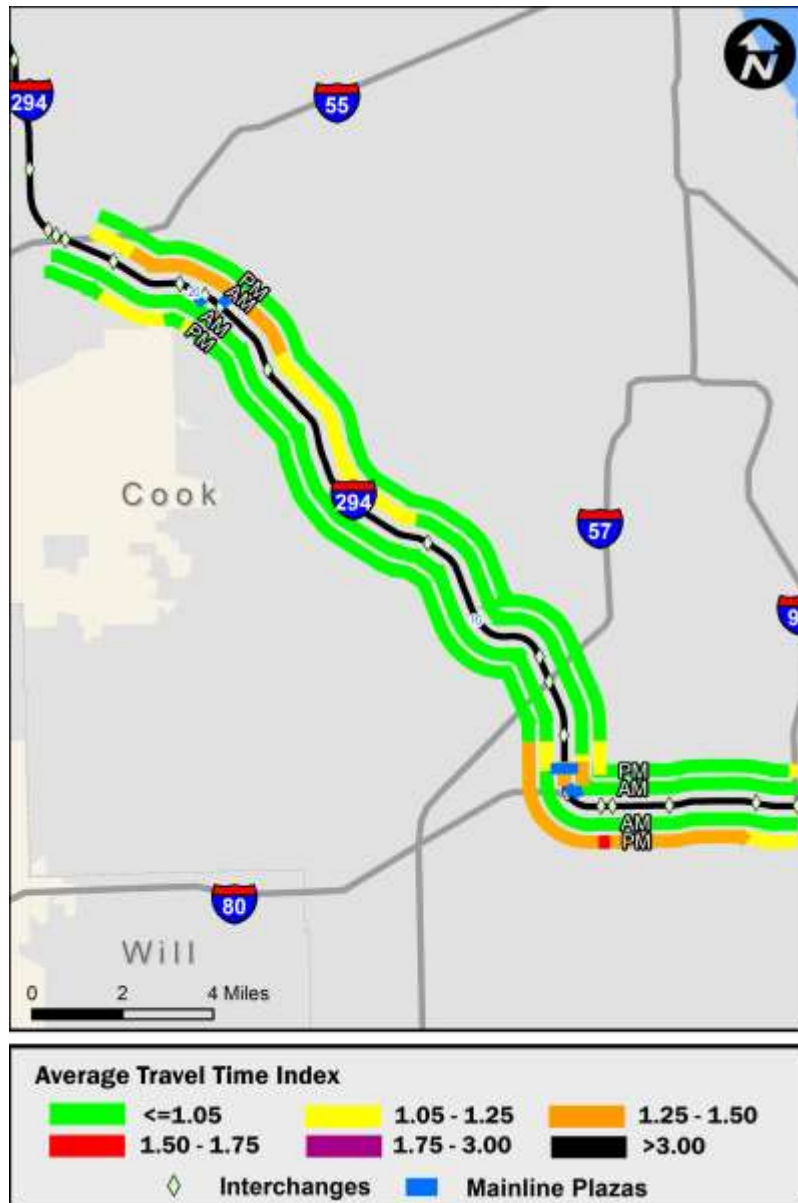

Quarter	Range	Average Speed (mph)		Average Travel Time Index		Planning Time Index		Total Delay (veh-hrs / 1000 VMT)		Average Daily Delay (veh-hrs)		Percent Congested Travel	
		AM	PM	AM	PM	AM	PM	AM	PM	AM	PM	AM	PM
1	January -March	60	62	1.00	0.97	1.11	1.09	1.1	0.5	667	317	17	14
2	April-June	56	59	1.08	1.01	1.18	1.25	2.3	1.3	1,484	910	26	16
3	July-September	57	58	1.05	1.03	1.18	1.36	1.9	1.6	1,177	1,109	25	18
4	October-December	57	60	1.06	1.00	1.16	1.15	2.0	0.8	1,217	568	25	19
Total	2016 Entire Year	57	60	1.05	1.00	1.16	1.21	1.8	1.1	1,136	726	23	17

Data source: INRIX. Roadway performance measures sections and terms are defined on pages 1-4 and 1-5.

FIGURE 3-AV: ROADWAY PERFORMANCE MEASURES, SOUTHERN SECTION

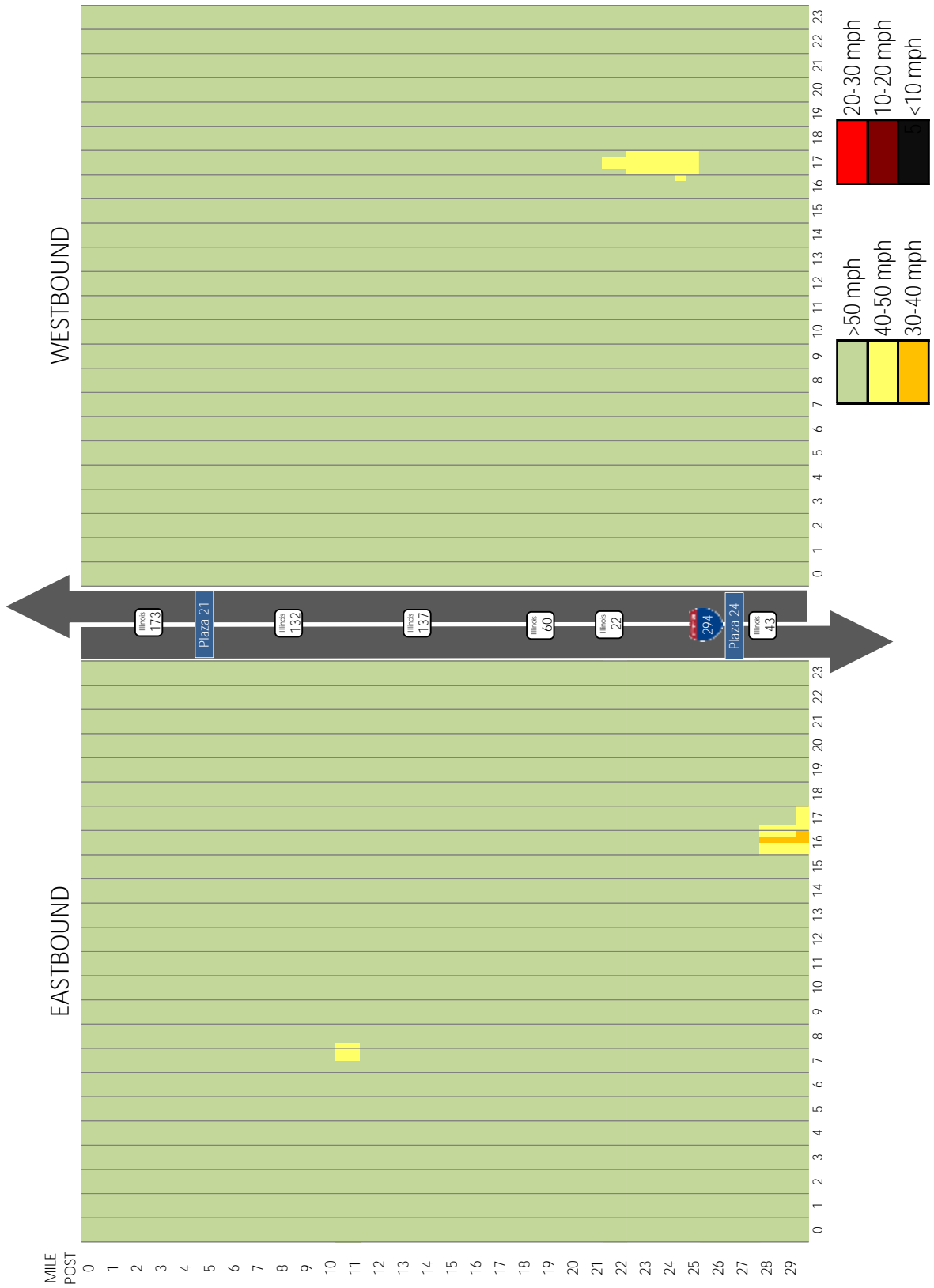

FIGURE 3-AW: AVERAGE SPEED CONTOURS I-94 MP 0.0 to 29.5

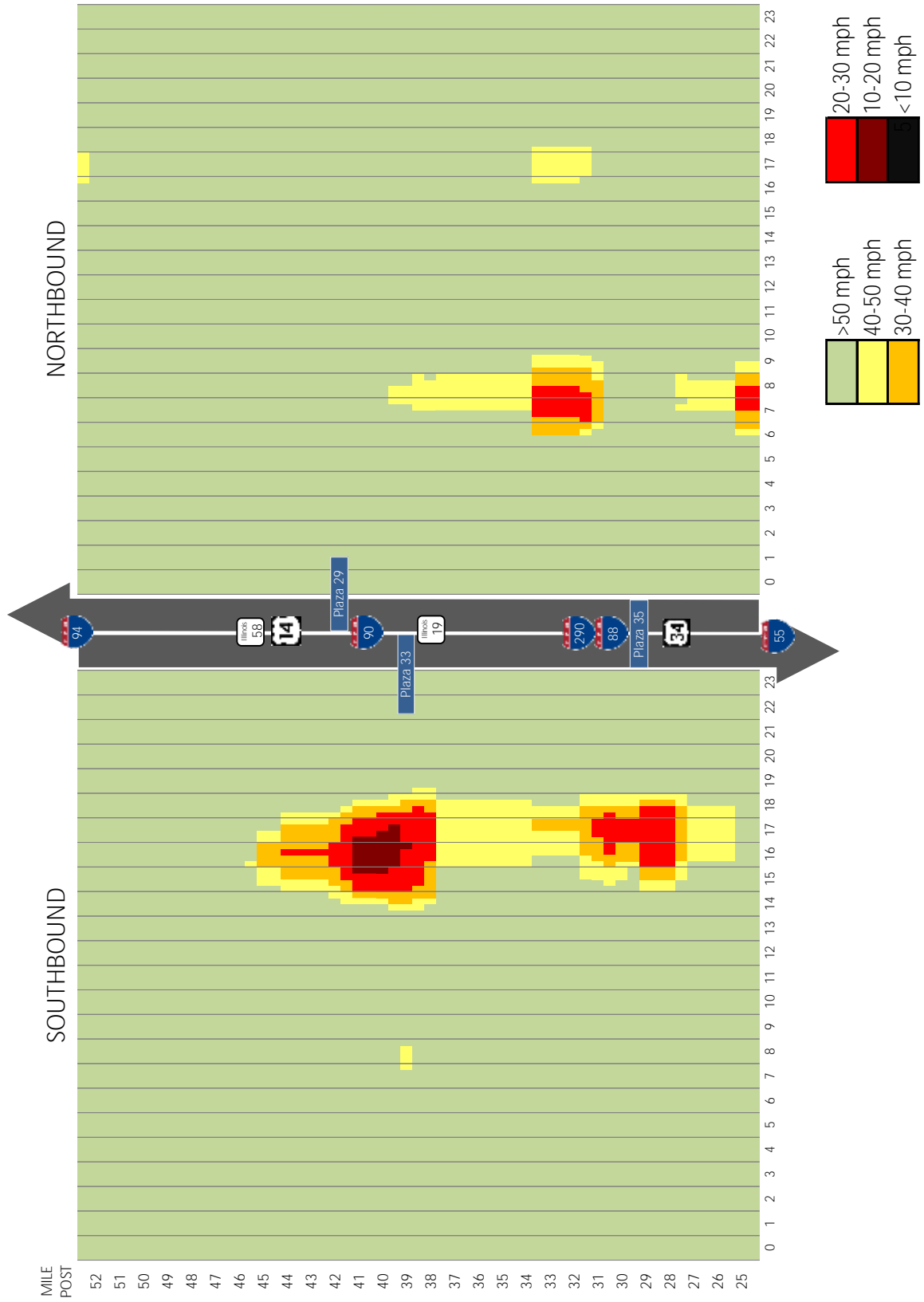

FIGURE 3-AX: AVERAGE SPEED CONTOURS, I-294 MP 24.5 TO 52.5

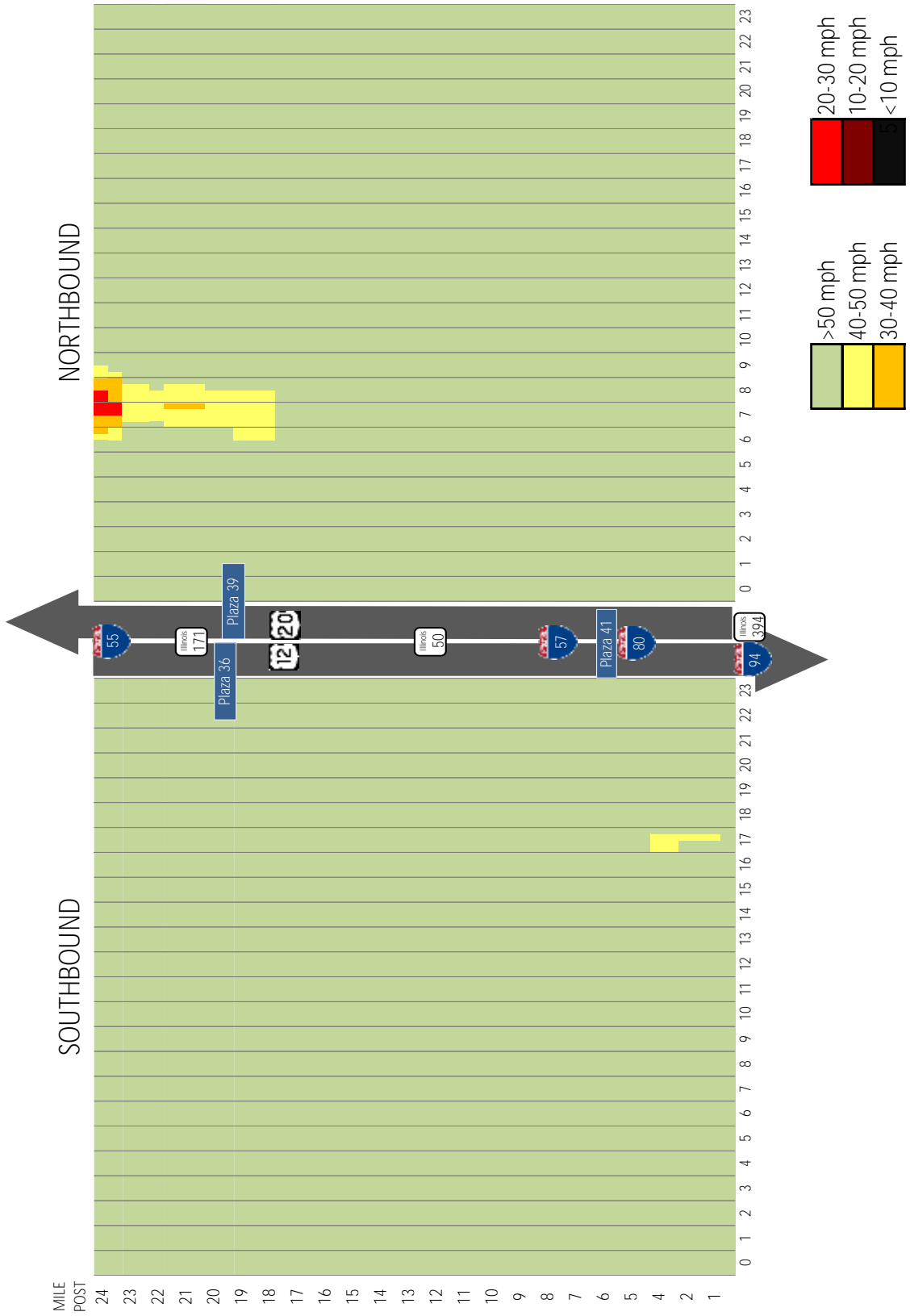

FIGURE 3-AY: AVERAGE SPEED CONTOURS, I-294 MP 0.5 TO 24.0



Section 4

Reagan Memorial Tollway



SECTION 4

Reagan Memorial Tollway

TABULATIONS TABLE

	PAGE
4-A Average Daily Traffic Volumes Between Interchanges 1980 – 2016 (Westbound)	4-4
4-B Average Daily Traffic Volumes Between Interchanges 1980 – 2016 (Eastbound)	4-5
4-C General Statistics for Mainline Plazas	4-6
4-D Indexed Monthly Variation by Mainline Plaza	4-8
4-E Indexed Daily Variation by Mainline Plaza	4-8
4-F Annual Total Transactions by Toll Plaza	4-9
4-G Average Daily Traffic Data	4-10

ILLUSTRATIONS FIGURE

	PAGE
4-A Mainline Plaza Highest Hourly Volume Plaza 51 WB	4-11
4-B Mainline Plaza Highest Hourly Volume Plaza 52 EB	4-11
4-C Mainline Plaza Highest Hourly Volume Plaza 61 EB	4-11
4-D Mainline Plaza Highest Hourly Volume Plaza 61 WB	4-11
4-E Mainline Plaza Highest Hourly Volume Plaza 66 EB	4-12
4-F Mainline Plaza Highest Hourly Volume Plaza 66 WB	4-12
4-G Mainline Plaza Highest Hourly Volume Plaza 69 EB	4-12
4-H Mainline Plaza Highest Hourly Volume Plaza 69 WB	4-12
4-I Average Daily Traffic Trends Plaza 51 York Road	4-13
4-J Average Daily Traffic Trends Plaza 52 Meyers Road	4-13
4-K Average Daily Traffic Trends Plaza 53 Spring Road	4-13
4-L Average Daily Traffic Trends Plaza 54 Illinois Route 83	4-14
4-M Average Daily Traffic Trends Plaza 55 Midwest Road	4-14
4-N Average Daily Traffic Trends Plaza 56 Highland Avenue	4-14
4-O Average Daily Traffic Trends Plaza 57 Naperville Road	4-15
4-P Average Daily Traffic Trends Plaza 58 Winfield Road	4-15
4-Q Average Daily Traffic Trends Plaza 59 Farnsworth Avenue	4-15
4-R Average Daily Traffic Trends Plaza 60 Eola Road	4-16
4-S Average Daily Traffic Trends Plaza 61 Aurora	4-16
4-T Average Daily Traffic Trends Plaza 63 Illinois Route 31	4-16



SECTION 4

Reagan Memorial Tollway

ILLUSTRATIONS (CONTINUED)

FIGURE		PAGE
--------	--	------

4-U	Average Daily Traffic Trends Plaza 64 Orchard Road	4-17
4-V	Average Daily Traffic Trends Plaza 65 Peace Road	4-17
4-W	Average Daily Traffic Trends Plaza 66 DeKalb	4-17
4-X	Average Daily Traffic Trends Plaza 67 Annie Glidden Road	4-18
4-Y	Average Daily Traffic Trends Plaza 69 Dixon	4-18
4-Z	Average Daily Traffic Trends Plaza 70 Illinois Route 26 West	4-18
4-AA	Average Daily Traffic Trends Plaza 71 Illinois Route 26 East	4-19
4-AB	Average Weekday Speed Distributions, Eastern Section—Eastbound	4-20
A-AC	Average Weekday Speed Distributions, Eastern Section—Westbound	4-20
4-AD	Average Weekday Speed Distributions, Western Section—Eastbound	4-20
4-AE	Average Weekday Speed Distributions, Western Section—Westbound	4-20
4-AF	Roadway Performance Measures, Eastern Section	4-21
4-AG	Roadway Performance Measures, Western Section	4-22
4-AH	Average Speed Contours, MP 117.0 to 140.0	4-23



This Page Is Intentionally Left Blank



TABLE 4-A: AVERAGE DAILY TRAFFIC VOLUMES BETWEEN INTERCHANGES 1980-2016 (WESTBOUND)

Location	Mile Post	Miles Btwn. Int.	ADT 1980	Average Annual Percent Change	ADT 1990	Average Annual Percent Change	ADT 2000	Average Annual Percent Change	ADT 2010	Average Annual Percent Change	ADT 2016
Eisenhower Expressway (I-290)	140.4										
		0.4	18,400	7.3	37,260	3.1	50,620	-0.7	47,270	3.8	59,010
Reagan Memorial Tollway (I-88)	140.0	1.1	24,050	5.4	40,610	3.6	57,780	2.0	70,480	-0.6	67,870
Harzer (York) Road	138.9	0.2	24,690	5.5	42,130	3.6	60,170	1.8	71,920	-0.6	69,290
Tollway South Leg	138.7										
Toll Plaza 51	138.1	0.9	31,790	5.7	55,350	3.1	75,420	0.4	78,160	2.7	91,600
Spring Road (PL53)	137.8										
		0.7	31,670	5.9	55,970	3.1	76,280	0.3	78,570	2.9	93,380
Kingery Highway (Illinois Route 83)	137.1										
		0.7	30,050	5.7	52,230	3.2	71,470	0.4	74,580	3.0	89,040
Midwest Road (PL55)	136.4										
Toll Plaza 52	135.1	2.1	28,230	6.0	50,500	3.5	71,470	0.4	74,580	3.0	89,040
Highland Avenue (PL56)	134.3										
		1.1	21,780	8.2	47,890	3.7	69,030	0.5	72,210	2.9	85,620
Veterans Memorial Tollway (E. Int)	133.2										
		1.9	21,780	7.8	46,120	3.3	64,090	-0.2	62,720	2.2	71,340
Veterans Memorial Tollway (W. Int)	131.3										
		1.3	21,780	9.4	53,340	3.7	76,590	0.6	81,220	1.8	90,420
Illinois Route 53	130.0										
		2.4	15,840	11.0	44,890	4.2	68,020	0.8	73,810	1.8	82,360
Naperville Road (PL57)	127.6										
		2.4	13,130	10.1	34,280	5.7	59,400	1.4	68,510	1.6	75,150
Winfield Road (PL58)	125.2										
		1.9	13,130	10.1	34,280	3.8	49,840	2.4	63,030	2.0	70,820
Illinois Route 59	123.3										
		1.9	8,260	10.4	22,160	4.1	33,140	4.3	50,400	1.8	56,120
Fola Road (PL60)	121.4										
		2.2	8,260	10.4	22,160	4.1	33,140	3.9	48,470	1.4	52,740
Farnsworth Avenue (PL59)	119.2										
Toll Plaza 61	117.8	2.2	6,870	9.4	16,900	4.0	24,970	4.4	38,250	1.6	42,120
Illinois Route 31 (PL63)	117.0										
		2.6	5,340	9.6	13,320	3.6	18,990	5.3	31,690	1.8	35,340
Orchard Road (PL64)	114.4										
		1.1	5,340	7.9	11,420	2.8	15,110	3.9	22,100	1.9	24,740
Illinois Route 56	113.3										
		4.0	3,170	7.7	6,680	3.8	9,710	3.5	13,740	2.2	15,660
Illinois Route 47	109.3										
		15.3	3,640	7.4	7,440	4.0	11,020	3.4	15,350	1.8	17,120
Peace Road (PL65)	94.0										
		0.7	2,550	7.4	5,230	5.2	8,680	3.7	12,440	0.8	13,070
DeKalb Oasis	93.3										
		1.9	2,550	7.4	5,230	5.2	8,680	3.7	12,440	0.8	13,070
Annie Glidden Road (PL67)	91.4										
Toll Plaza 66	86.2	12.9	2,010	8.3	4,480	5.4	7,550	2.3	9,480	2.4	10,900
Interstate 39	78.5										
		2.4	2,010	8.4	4,500	4.8	7,200	1.8	8,610	0.2	8,690
U.S. Route 51 (Illinois Route 251)	76.1										
Toll Plaza 69	56.4	22.2	2,350	5.5	4,030	5.0	6,570	1.3	7,460	-0.4	7,270
Illinois Route 26 (Dixon)	53.9										
		9.7	2,510	4.3	3,820	4.5	5,920	2.0	7,220	-0.4	7,050
U.S. Route 30 West Terminus	44.2										
Reagan Connector		1.4	7,100	6.4	13,220	1.4	15,250	2.4	19,260	2.5	22,310



TABLE 4-B: AVERAGE DAILY TRAFFIC VOLUMES BETWEEN INTERCHANGES 1980-2016 (EASTBOUND)

Location	Mile Post	Miles Btwn. Int.	ADT 1980	Average Annual Percent Change	ADT 1990	Average Annual Percent Change	ADT 2000	Average Annual Percent Change	ADT 2010	Average Annual Percent Change	ADT 2016
Eisenhower Expressway (I-290)	140.4										
		0.4	15,290	6.7	29,300	4.3	44,490	0.7	47,580	2.1	53,970
Reagan Memorial Tollway (I-88)	140.0										
		1.1	21,750	5.0	35,360	4.2	53,170	0.3	54,630	2.9	64,970
Harger (York) Road	138.9										
		0.2	21,750	5.0	35,360	4.2	53,170	0.3	54,630	2.9	64,970
Reagan Connector	138.7										
Toll Plaza 51	138.1	0.9	30,390	5.6	52,500	3.1	71,030	0.8	76,930	3.2	92,830
Spring Road	137.8										
		0.7	30,390	5.6	52,500	3.1	71,030	0.8	76,930	3.2	92,830
Illinois Route 83 (PL54)	137.1										
		0.7	27,930	5.5	47,610	3.0	64,000	0.8	69,510	3.3	84,500
Midwest Road (PL55)	136.4										
Toll Plaza 52	135.1	2.1	28,740	5.7	50,050	3.4	70,000	0.6	73,950	3.1	88,570
Highland Avenue (PL56)	134.3										
		1.1	22,500	7.5	46,280	4.0	68,610	0.8	74,300	2.9	88,370
Veterans Memorial Tollway (E. Int)	133.2										
		1.9	22,500	8.6	51,280	4.4	78,680	0.2	80,450	1.7	89,240
Veterans Memorial Tollway (W. Int)	131.3										
		1.3	22,500	8.9	52,980	3.9	77,900	0.4	81,280	1.7	89,720
Illinois Route 53	130.0										
		2.4	16,500	10.5	44,710	4.4	68,790	0.9	74,980	1.7	83,020
Naperville Road	127.6										
		2.4	13,620	9.8	34,550	5.5	59,040	1.7	70,040	1.0	74,240
Winfield Road (PL58)	125.2										
		1.9	13,620	9.8	34,550	3.9	50,840	2.5	64,810	0.9	68,510
Illinois Route 59	123.3										
		1.9	8,740	10.0	22,610	4.1	33,790	4.3	51,490	1.9	57,700
Fola Road (PL60)	121.4										
		2.2	8,740	10.0	22,610	4.1	33,790	3.7	48,630	1.4	52,730
Farnsworth Avenue (PL59)	119.2										
Toll Plaza 61	117.8	2.2	7,170	9.1	17,180	4.0	25,370	4.4	38,890	1.7	42,910
Illinois Route 31 (PL63)	117.0										
		2.6	5,500	9.4	13,560	3.5	19,170	5.2	31,930	1.9	35,710
Orchard Road (PL64)	114.4										
		1.1	5,500	7.7	11,510	3.5	16,160	3.1	21,860	2.0	24,580
Illinois Route 56	113.3										
		4.0	3,110	8.0	6,690	3.8	9,720	3.4	13,580	2.3	15,560
Illinois Route 47	109.3										
		15.3	3,570	7.6	7,400	4.0	10,990	3.2	15,090	1.9	16,920
Peace Road (PL65)	94.0										
		0.7	2,620	7.4	5,370	5.1	8,800	3.4	12,270	1.0	13,000
DeKalb Oasis	93.3										
		1.9	2,620	7.4	5,370	5.1	8,800	3.4	12,270	1.0	13,000
Annie Glidden Road (PL67)	91.4										
Toll Plaza 66	86.2	12.9	2,050	8.0	4,440	5.4	7,530	2.2	9,320	2.4	10,720
Interstate 39	78.5										
		2.4	2,050	8.4	4,580	4.6	7,190	1.8	8,560	-0.2	8,480
Illinois Route 251	76.1										
Toll Plaza 69	56.4	22.2	2,340	5.8	4,120	4.8	6,610	0.9	7,200	-0.4	7,020
Illinois Route 26	53.9										
		9.7	2,460	4.4	3,780	4.7	6,010	1.6	7,030	-0.4	6,860
U.S. Route 30 West Terminus	44.2										
Reagan Connector		1.4	7,050	6.5	13,180	-0.5	12,500	4.4	19,260	2.6	22,430



**TABLE 4-C: GENERAL STATISTICS FOR MAINLINE PLAZAS
(Vehicles/Hour)**

Mainline Plaza	Dir.	30th HV	Period	Mean	Med.	Max.	Min.	Std. Dev.	85th %
51 York Road	WB	7,828	AM Peak	6,302	5,621	7,976	3,872	1,202	7,683
			PM Peak	7,017	7,109	7,646	5,395	455	7,406
			OFF Peak	3,539	3,838	7,899	249	2,209	5,933
			Weekend	3,550	3,627	7,697	379	2,020	5,639
			Holidays	3,114	3,109	7,134	246	1,887	5,122
52 Meyers Road	EB	8,052	AM Peak	7,400	7,494	8,367	4,954	594	7,931
			PM Peak	6,493	6,511	7,642	4,098	509	6,954
			OFF Peak	3,356	3,797	7,983	207	2,172	5,585
			Weekend	3,394	3,497	7,897	289	2,064	5,510
			Holidays	3,014	3,058	6,885	258	1,906	5,235
61 Aurora	EB	4,879	AM Peak	4,508	4,572	5,014	3,093	373	4,820
			PM Peak	2,624	2,615	3,120	2,191	193	2,820
			OFF Peak	1,550	1,619	3,982	123	1,021	2,628
			Weekend	1,676	1,683	4,741	128	1,082	2,770
			Holidays	1,546	1,481	4,218	114	1,037	2,718
	WB	5,137	AM Peak	1,972	1,844	2,523	1,196	342	2,365
			PM Peak	4,785	4,815	5,305	3,811	262	5,040
			OFF Peak	1,560	1,697	4,457	120	1,072	2,503
			Weekend	1,633	1,645	5,303	112	1,080	2,559
			Holidays	1,480	1,479	4,745	105	1,043	2,352
66 DeKalb	EB	1,356	AM Peak	489	492	601	350	43	530
			PM Peak	708	697	1,018	492	104	818
			OFF Peak	380	397	1,157	32	225	617
			Weekend	481	452	1,498	24	337	855
			Holidays	507	440	1,583	20	405	1,017
	WB	1,303	AM Peak	574	569	797	396	84	666
			PM Peak	671	668	923	455	95	775
			OFF Peak	388	340	1,034	36	243	669
			Weekend	486	469	1,642	20	333	862
			Holidays	489	423	1,543	19	387	898

(cont'd)



**TABLE 4-C: GENERAL STATISTICS FOR MAINLINE PLAZAS
(Vehicles/Hour)**

Mainline Plaza	Dir.	30th HV	Period	Mean	Med.	Max.	Min.	Std. Dev.	85th %
69 Dixon	EB	932	AM Peak	245	243	319	163	32	280
			PM Peak	434	427	685	243	78	514
			OFF Peak	246	231	751	26	146	408
			Weekend	330	295	1,195	16	232	597
			Holidays	346	289	1,121	15	272	666
	WB	902	AM Peak	310	314	515	188	55	367
			PM Peak	406	404	605	275	58	463
			OFF Peak	259	239	790	25	151	427
			Weekend	334	320	1,481	18	224	588
			Holidays	353	305	1,141	21	271	657

AM Peak = Weekday 6:00 AM To 8:00 AM Except Fridays
 PM Peak = Weekday 4:00 PM To 6:00 PM Except Fridays
 OFF Peak = Weekdays Except Fridays and AM and PM Peak Periods
 Weekend = Fridays, Saturdays, and Sundays
 Holidays = See Page 1-6 for a list of Holidays.



TABLE 4-D: INDEXED MONTHLY VARIATION BY MAINLINE PLAZA

Month	York Road	Meyers Road	Aurora	DeKalb	Dixon
January	0.90	0.89	0.88	0.80	0.81
February	0.96	0.95	0.95	0.84	0.85
March	0.99	1.00	1.00	0.97	1.03
April	1.01	1.01	1.02	0.97	0.94
May	1.02	1.03	1.05	1.05	0.99
June	1.05	1.06	1.07	1.11	1.02
July	1.01	1.01	1.00	1.15	1.12
August	1.04	1.04	1.03	1.08	1.09
September	1.03	1.03	1.03	1.06	1.06
October	1.03	1.03	1.04	1.05	1.06
November	1.01	1.01	1.01	1.02	1.06
December	0.95	0.95	0.93	0.90	0.96

TABLE 4-E: INDEXED DAILY VARIATION BY MAINLINE PLAZA

Month	Day	York Road	Meyers Road	Aurora	DeKalb	Dixon
August	Monday	1.06	1.05	1.03	1.06	1.08
	Tuesday	1.03	1.03	1.01	1.05	1.08
	Wednesday	1.04	1.03	1.02	1.07	1.09
	Thursday	1.02	1.03	1.01	1.08	1.11
	Friday	1.03	1.02	1.02	1.08	1.06
	Saturday	1.03	1.02	1.02	1.11	1.11
	Sunday	1.08	1.07	1.07	1.19	1.17
December	Monday	0.93	0.94	0.91	0.96	1.07
	Tuesday	0.98	0.99	0.97	1.01	1.09
	Wednesday	0.99	0.99	0.99	1.01	1.07
	Thursday	0.98	0.99	0.97	0.97	1.04
	Friday	0.96	0.95	0.93	0.87	0.94
	Saturday	0.91	0.90	0.88	0.79	0.84
	Sunday	0.80	0.81	0.78	0.67	0.70

Table 4-E includes Monthly Variation

TABLE 4-F: ANNUAL TOTAL TRANSACTIONS BY TOLL PLAZA

Plaza	Plaza Code*	2015	2016	Percentage Change
51 York Road	M1	32,633,275	33,525,373	2.7%
52 Meyers Road	M1	31,323,899	32,420,400	3.5%
53 Spring Road	R1	3,230,519	3,193,910	-1.1%
54 Illinois Route 83	R1	3,036,363	3,047,516	0.4%
55 Midwest Road	R1	1,576,824	1,639,493	4.0%
56 Highland Avenue	R	5,554,698	5,527,382	-0.5%
57 Naperville Road	R	3,950,542	4,077,578	3.2%
58 Winfield Road	R	3,011,336	2,807,698	-6.8%
59 Farnsworth Avenue	R	9,945,951	9,708,375	-2.4%
60 Eola Road	E	4,625,480	4,162,045	-10.0%
61 Aurora	M	30,404,028	31,121,255	2.4%
63 Illinois Route 31	R	1,161,038	1,423,608	22.6%
64 Orchard Road	R	1,584,569	1,617,784	2.1%
65 Peace Road	R	3,381,560	3,512,201	3.9%
66 DeKalb Mainline	M	7,660,145	7,909,084	3.2%
67 Annie Glidden Road	R	1,931,255	1,988,058	2.9%
69 Dixon Mainline	M	5,011,994	5,228,203	4.3%
Reagan Memorial Total		150,023,476	152,909,963	1.9%

* M=Mainline / R=Ramp / A=Attended Ramp Plaza / E=Electronic Toll Collection Only Ramp
 1=Toll Collected in One Direction Only



TABLE 4-G: AVERAGE DAILY TRAFFIC DATA

Year	Average Daily Total			Average Trip
	Vehicles	Vehicle Miles	Transactions	Length (Miles)
1959	8,440	165,204	12,808	19.57
1960	12,276	203,116	16,744	16.55
1961	16,312	257,837	21,563	15.81
1962	17,764	288,501	24,029	16.24
1963	16,569	279,454	23,257	16.87
1964	16,995	264,758	21,574	15.58
1965	17,995	271,692	22,776	15.10
1966	17,947	285,535	25,748	15.91
1967	19,729	311,452	28,672	15.79
1968	22,809	341,062	31,370	14.95
1969	26,158	389,376	36,732	14.89
1970	29,164	429,270	41,225	14.72
1971	31,899	477,703	46,504	14.98
1972	37,858	538,511	52,714	14.22
1973	43,598	599,398	59,488	13.75
1974	41,427	634,698	61,858	15.32
1975	46,937	824,125	74,039	17.56
1976	51,443	907,679	80,957	17.64
1977	52,795	942,618	83,086	17.85
1978	62,128	1,141,523	98,673	18.37
1979	65,025	1,209,224	102,678	18.60
1980	66,901	1,237,492	106,458	18.50
1981	69,977	1,237,492	112,541	17.68
1982	73,089	1,366,570	124,900	18.70
1983	83,292	1,501,330	126,523	18.02
1984	89,716	1,619,407	137,718	18.05
1985	95,566	1,760,944	148,154	18.43
1986	104,972	1,933,134	166,784	18.42
1987	113,033	2,064,188	180,166	18.26
1988	118,956	2,211,706	190,996	18.59
1989	119,346	2,289,542	196,542	19.18
1990	129,849	2,587,888	212,457	19.93
1991	132,723	2,552,325	207,433	19.23
1992	139,437	2,722,109	216,466	19.52
1993	148,050	2,846,936	224,192	19.23
1994	154,551	3,146,111	246,079	20.36
1995	162,260	3,357,807	259,860	20.69
1996	167,010	3,477,775	275,061	20.82
1997	186,370	3,471,458	274,429	18.63
1998	200,930	3,492,638	274,660	17.38
1999	214,190	3,824,597	298,242	17.86
2000	218,150	3,900,147	305,567	17.88
2001	226,930	4,006,550	316,753	17.66
2002	232,780	4,288,781	341,362	18.42
2003	239,380	4,478,762	348,386	18.71
2004	243,640	4,606,017	359,964	18.91
2005	238,580	4,441,784	350,311	18.62
2006	240,500	4,540,450	359,564	18.88
2007	243,310	4,603,873	359,357	18.92
2008	239,410	4,344,648	333,079	18.15
2009	243,680	4,417,393	336,193	18.13
2010	239,680	4,650,235	372,523	19.40
2011	255,540	4,925,591	392,112	19.28
2012	242,590	4,596,370	373,479	18.95
2013	236,900	4,809,676	386,982	20.30
2014	239,890	4,999,058	398,674	20.84
2015	247,280	5,061,140	411,023	20.47
2016	250,550	5,182,530	417,787	20.68



FIGURE 4-B

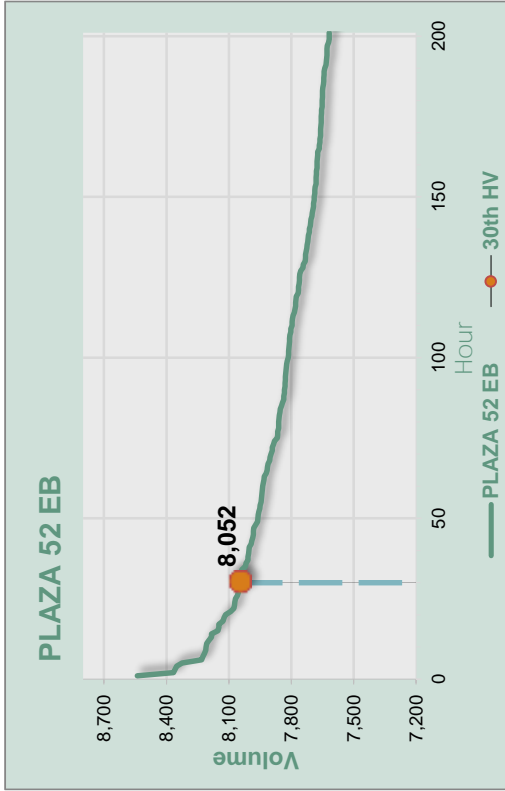

FIGURE 4-A

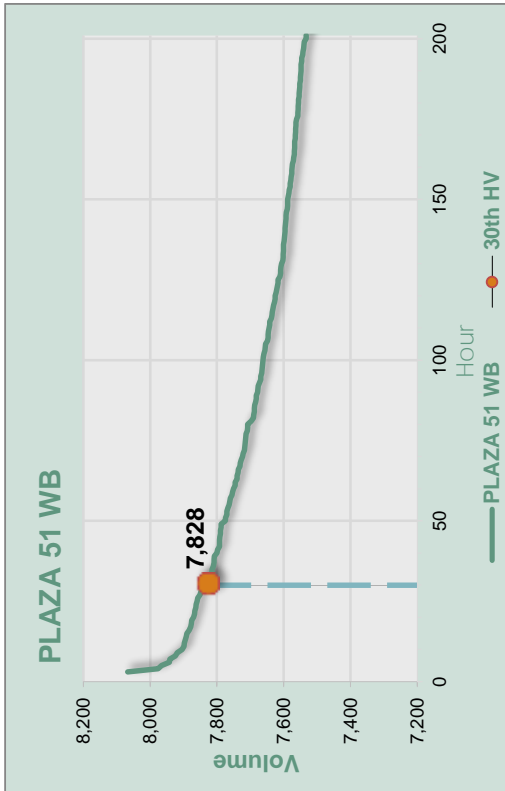

FIGURE 4-D

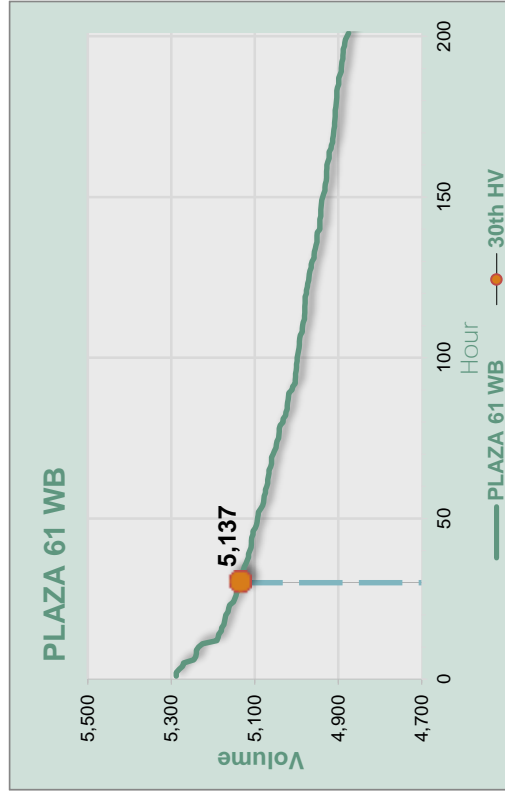
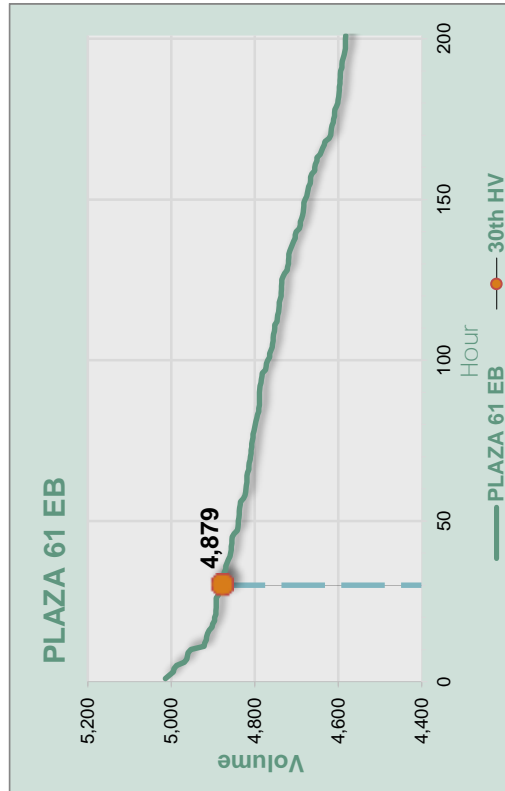

FIGURE 4-C



MAINLINE PLAZA HIGHEST HOURLY VOLUME



FIGURE 4-F

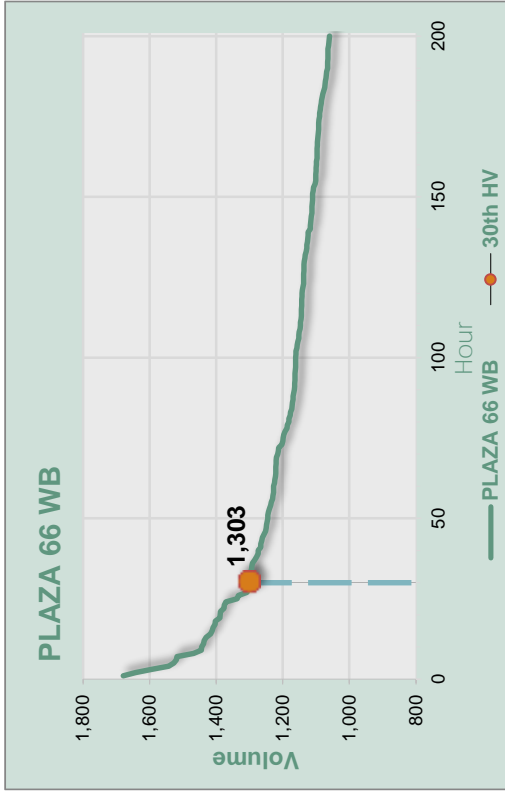

FIGURE 4-H

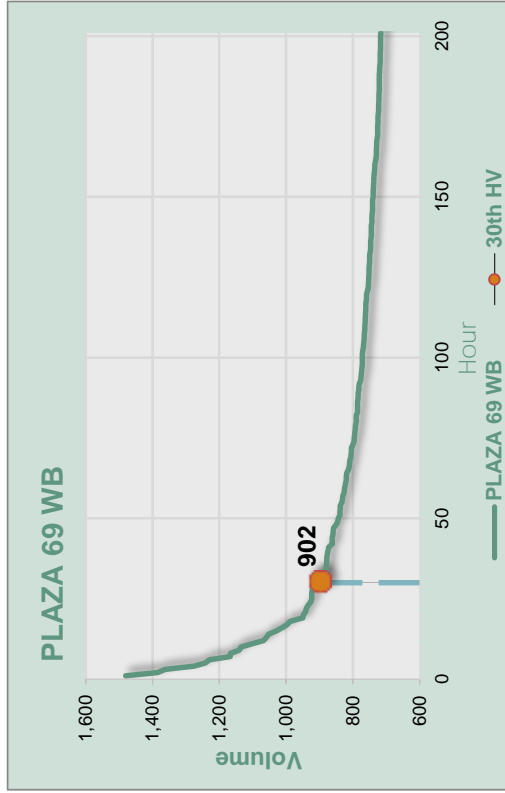

FIGURE 4-E

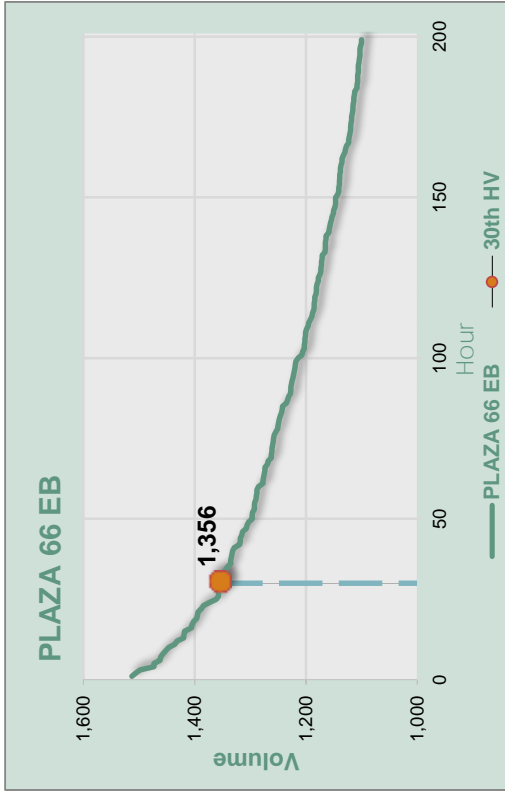
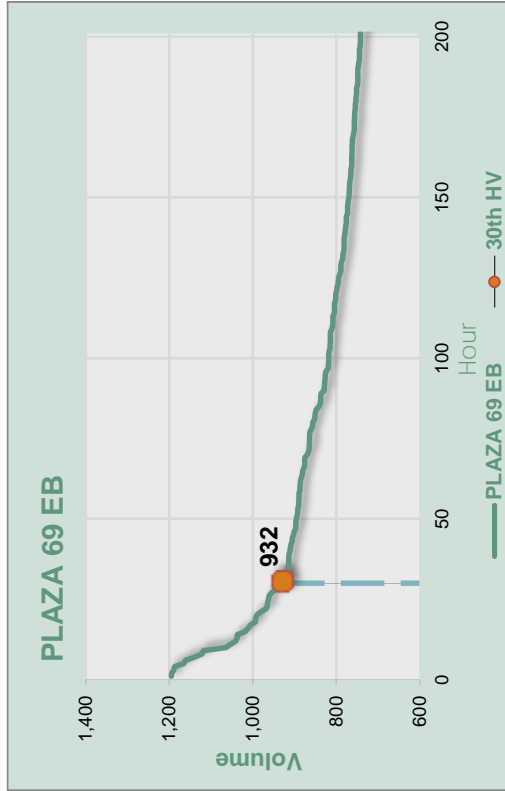

FIGURE 4-G



MAINLINE PLAZA HIGHEST HOURLY VOLUME



FIGURE 4-I

The eastbound side of Plaza 51 closed in 2006 and was replaced by Plaza 52.

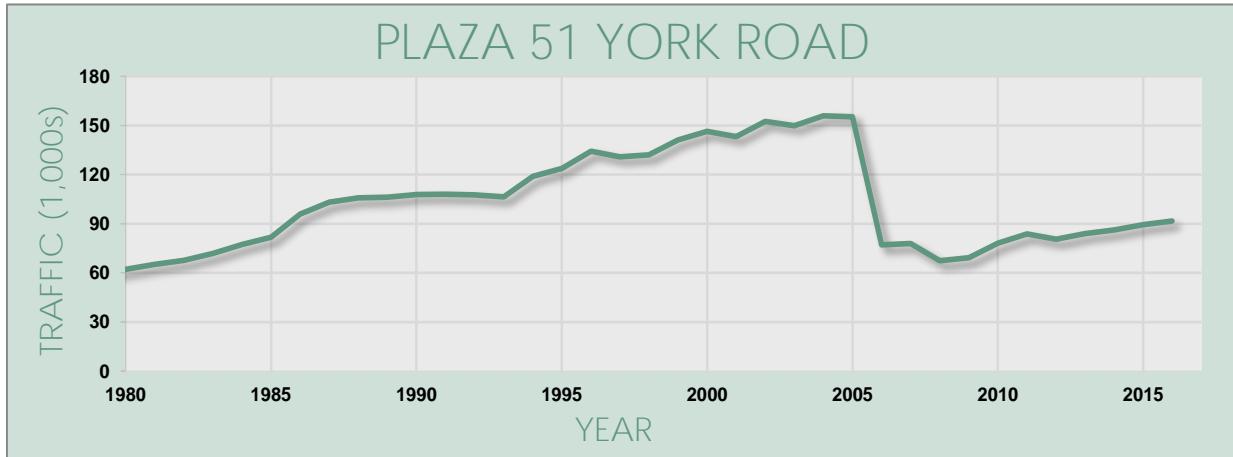

FIGURE 4-J

Plaza 52 opened in 2006 to replace eastbound Plaza 51.

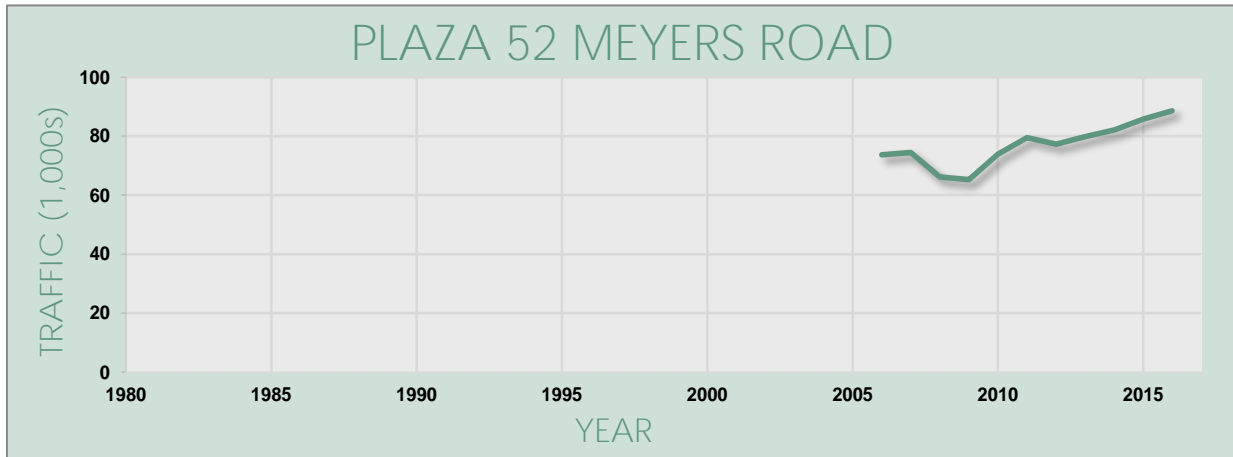
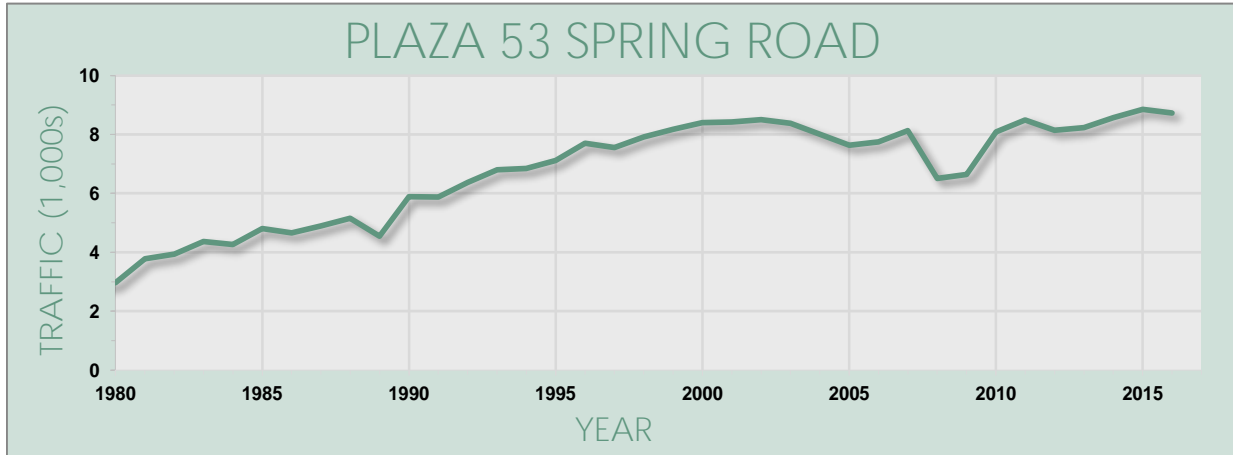

FIGURE 4-K



AVERAGE DAILY TRAFFIC TRENDS



FIGURE 4-L

Plaza 54 opened in 2006 due to Plaza 51 reconfiguration.

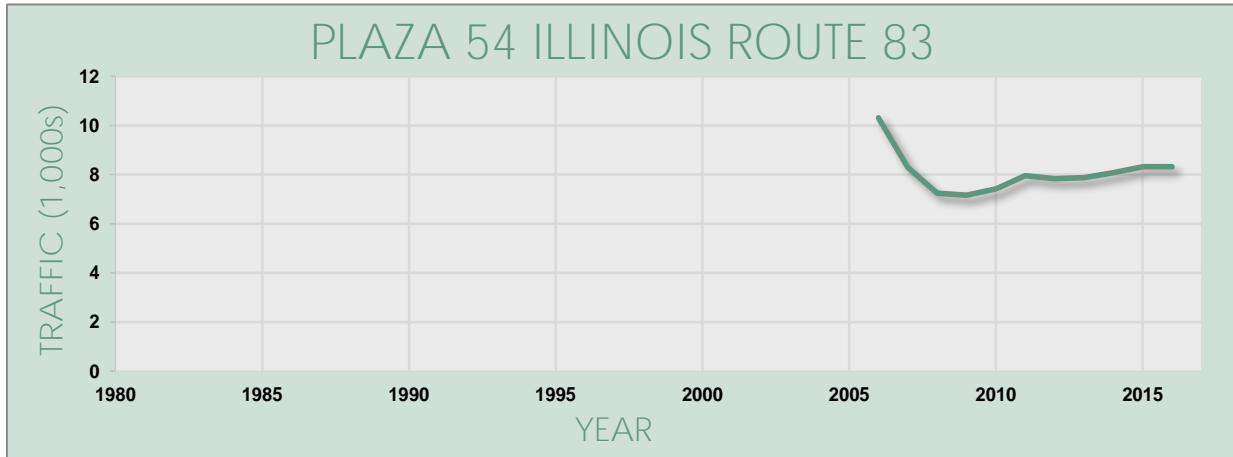

FIGURE 4-M

Plaza 55 was moved from the exit ramp to the entrance ramp in 2006 due to Plaza 51 reconfiguration..

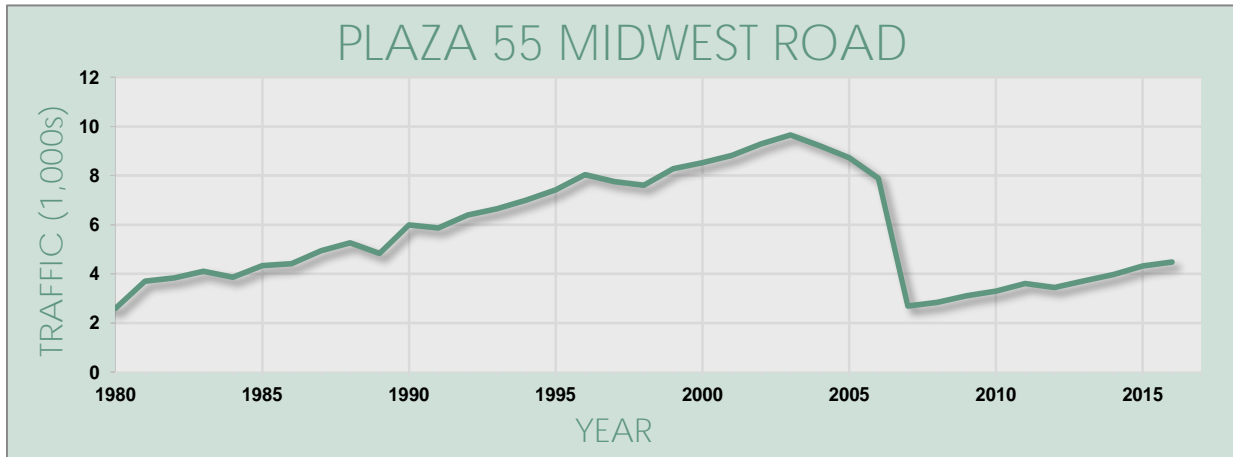
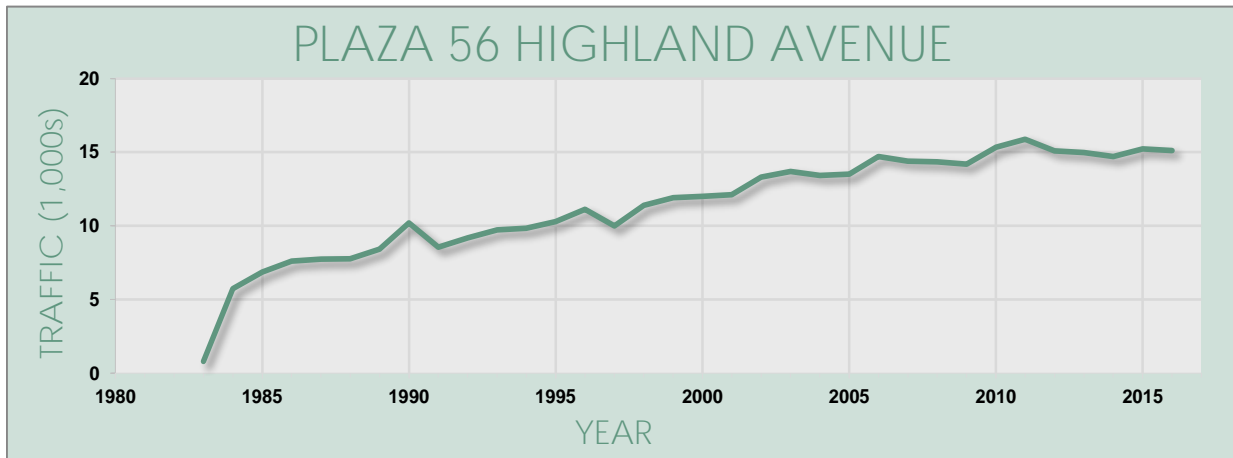

FIGURE 4-N



AVERAGE DAILY TRAFFIC TRENDS



FIGURE 4-O

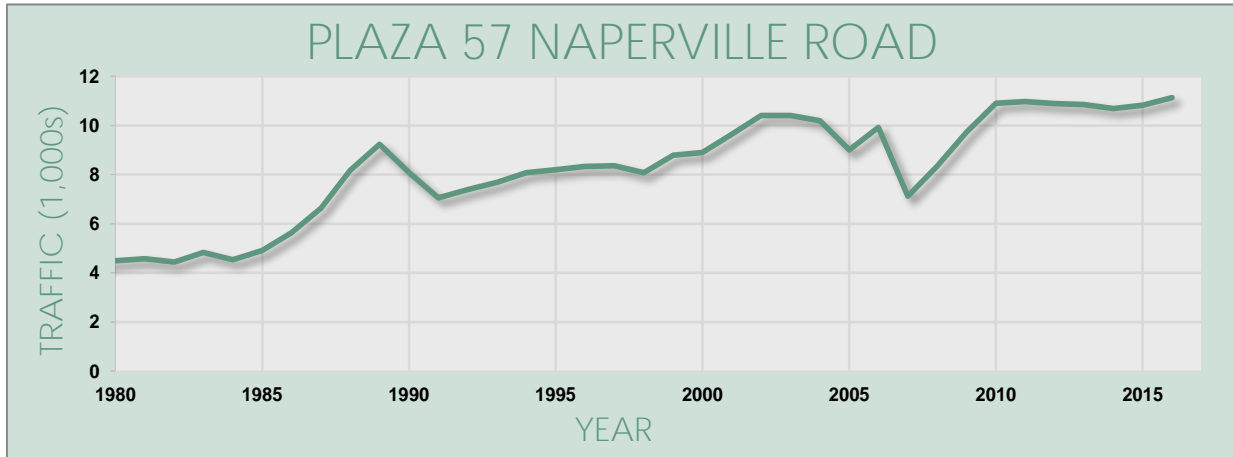

FIGURE 4-P

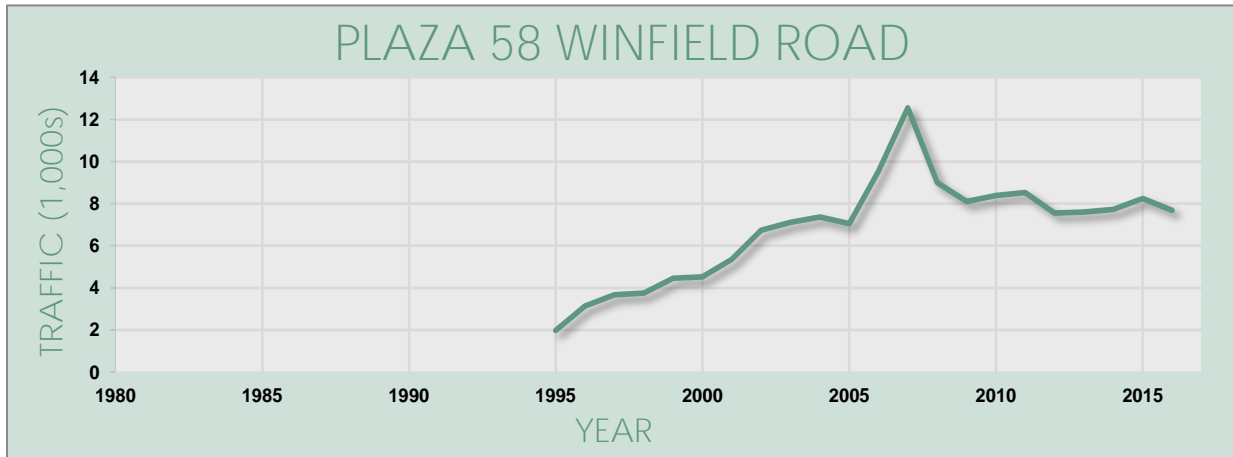
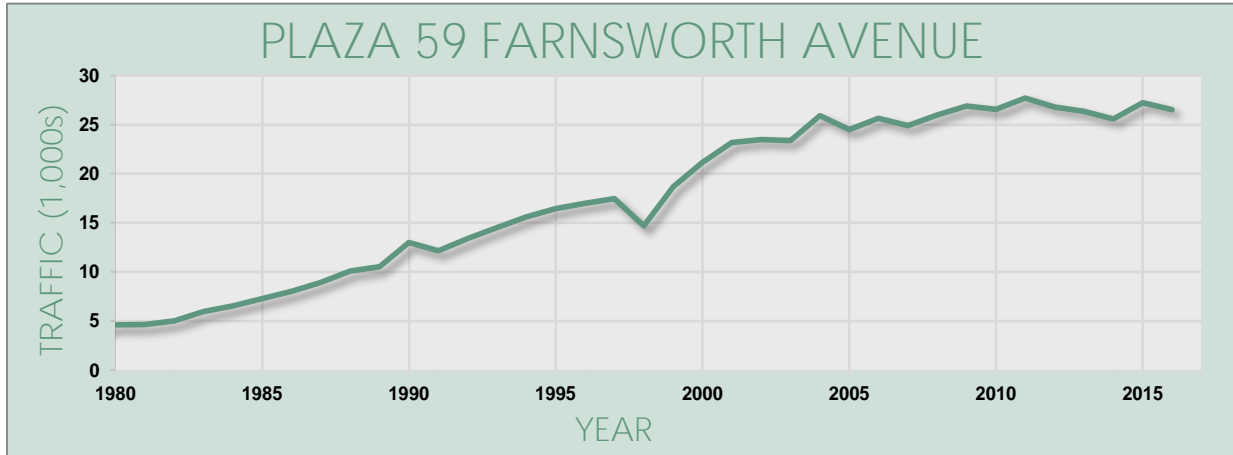

FIGURE 4-Q



AVERAGE DAILY TRAFFIC TRENDS



FIGURE 4-R

Plaza 60 opened in 2009.

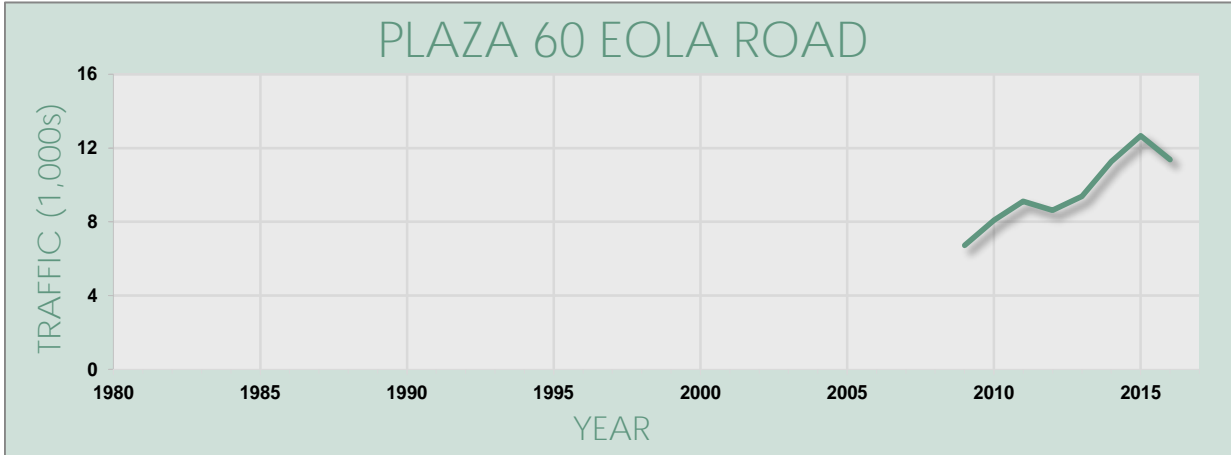

FIGURE 4-S

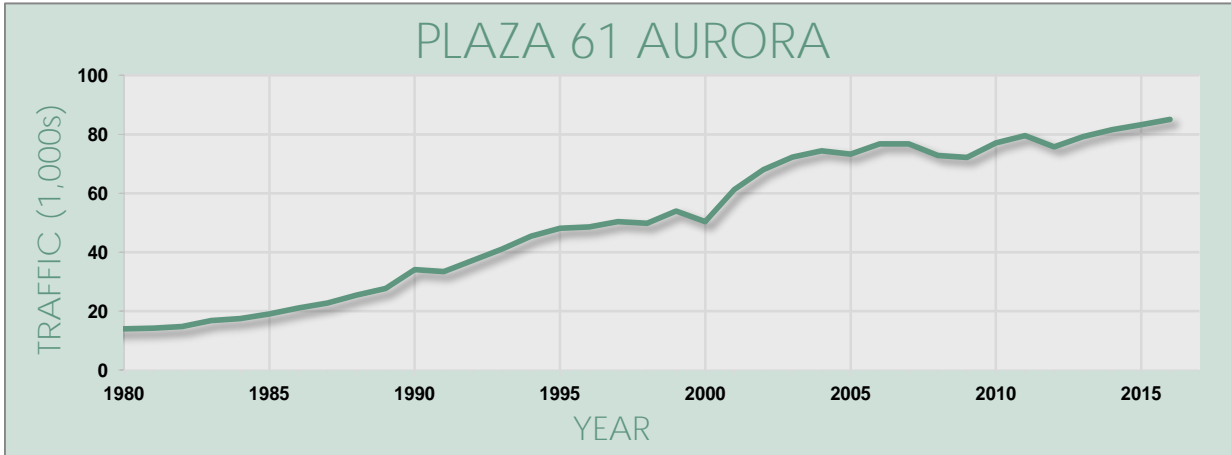
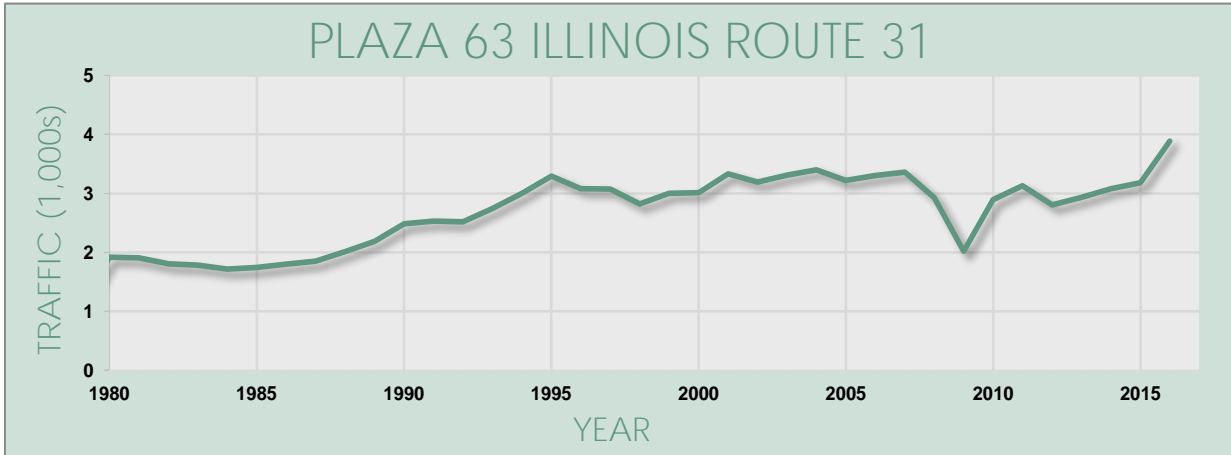

FIGURE 4-T



AVERAGE DAILY TRAFFIC TRENDS



FIGURE 4-U

Plaza 64 opened in 1997

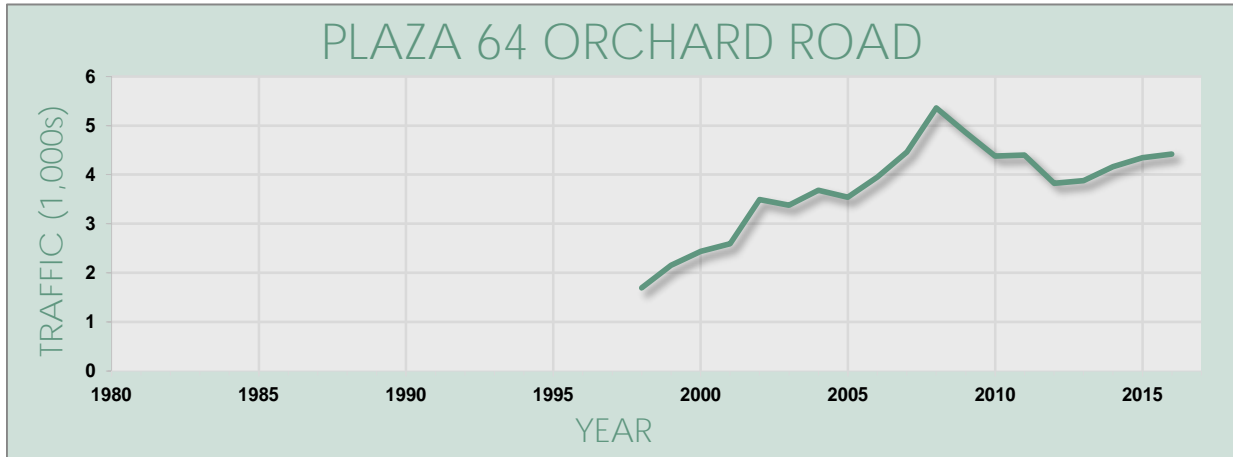

FIGURE 4-V

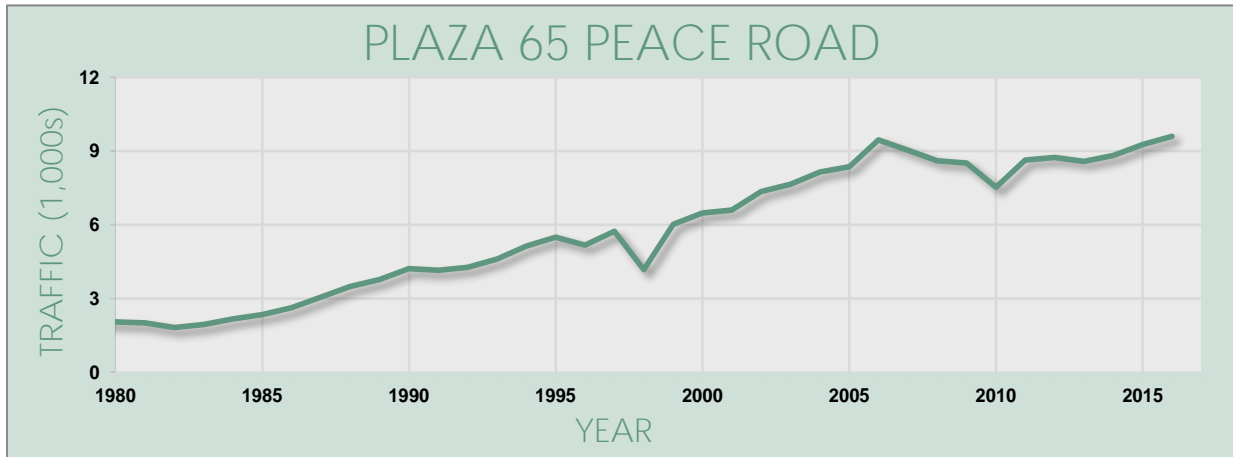
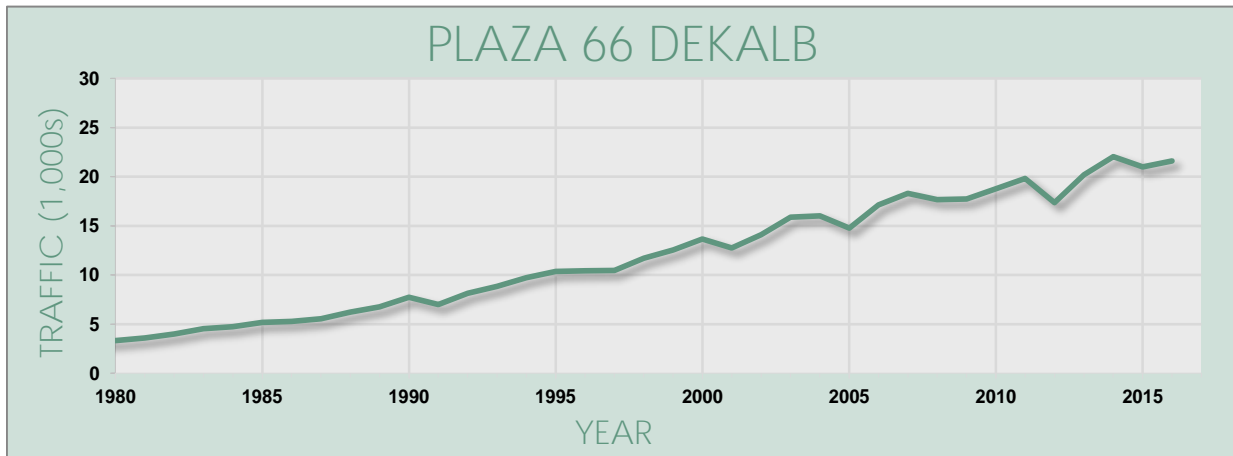

FIGURE 4-W



AVERAGE DAILY TRAFFIC TRENDS



FIGURE 4-X

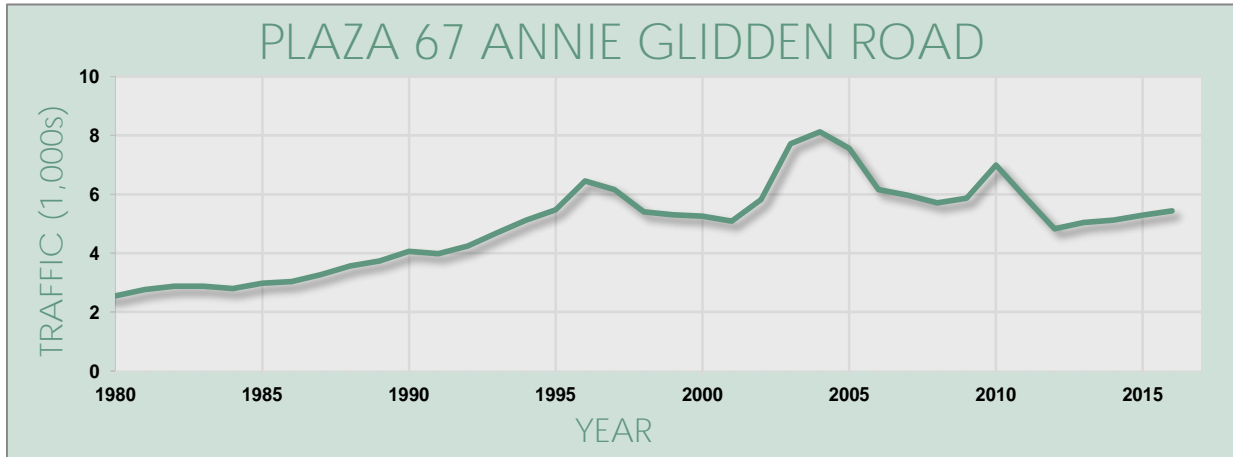

FIGURE 4-Y

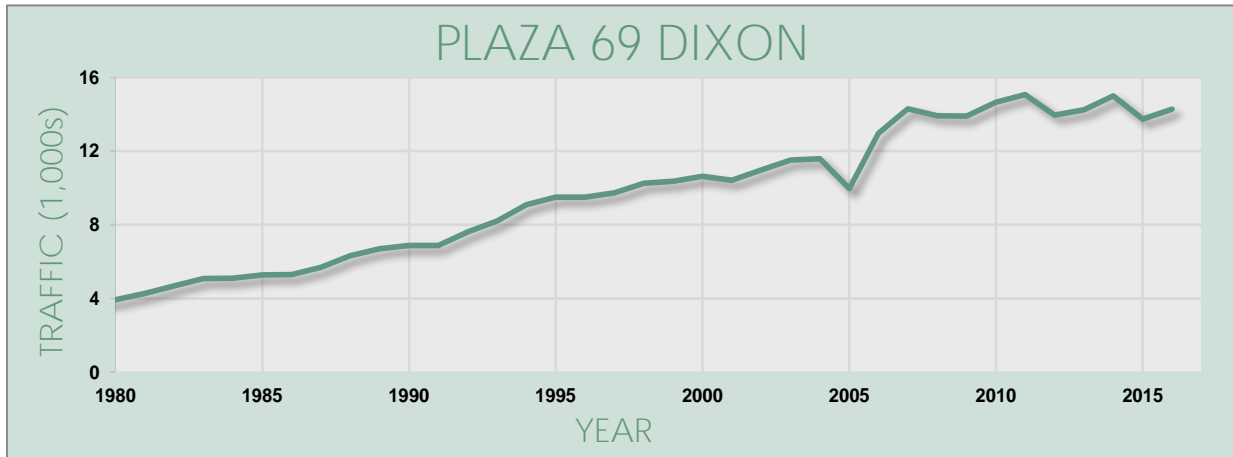
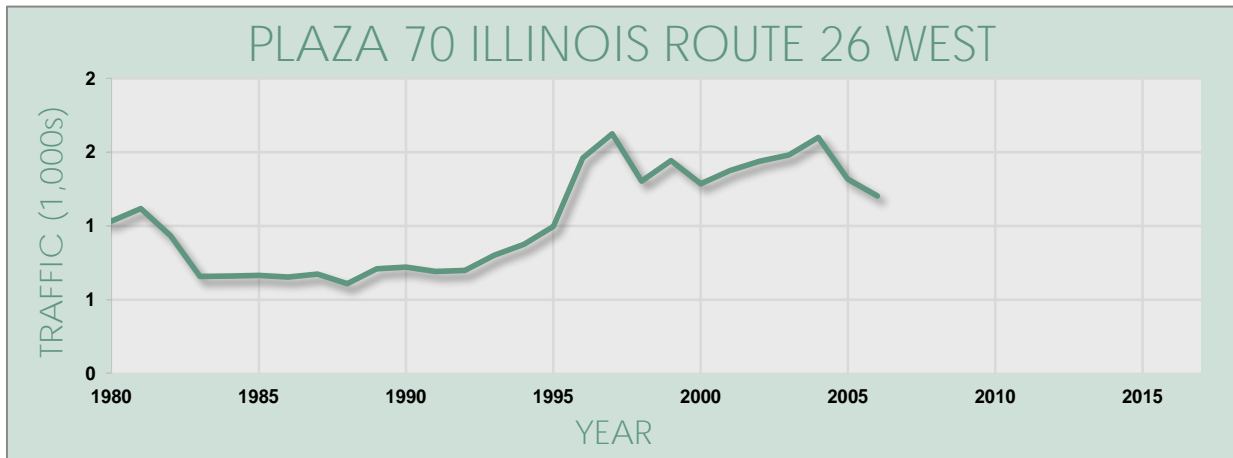

FIGURE 4-Z

Plaza 70 was removed in 2006.



AVERAGE DAILY TRAFFIC TRENDS



FIGURE 4-AA

Plaza 71 was removed in 2006.

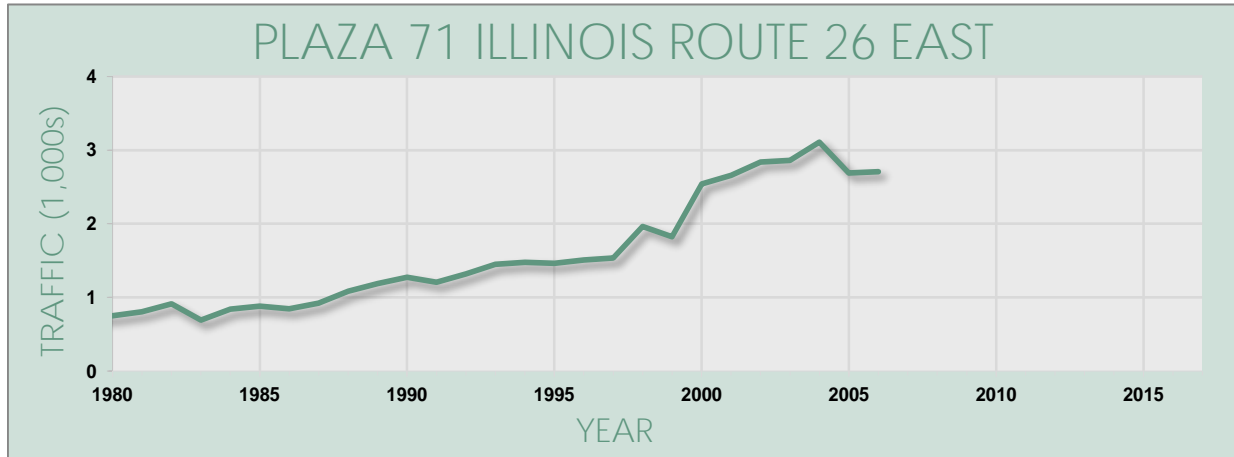

AVERAGE DAILY TRAFFIC TRENDS



AVERAGE WEEKDAY SPEED DISTRIBUTIONS, EASTERN SECTION

FIGURE 4-AB

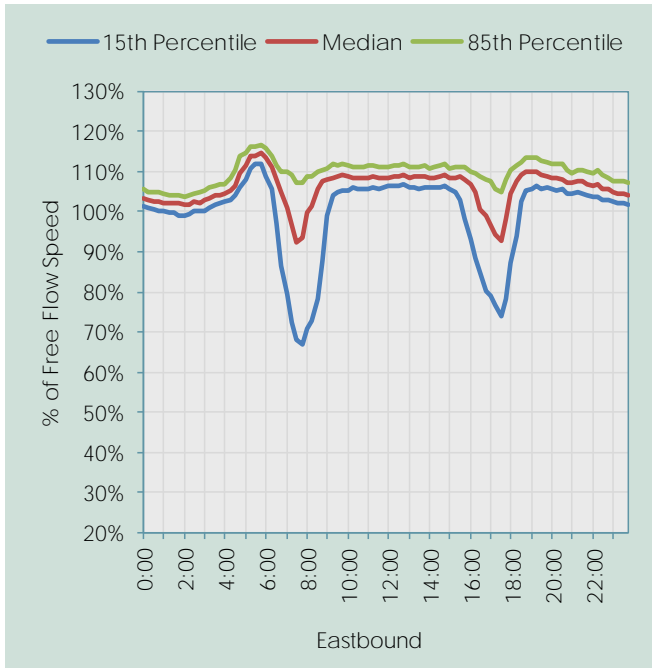
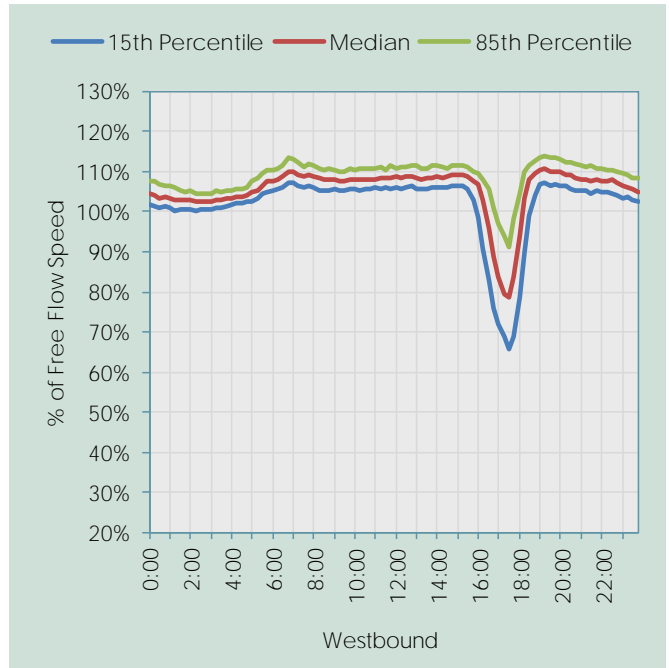

FIGURE 4-AC



AVERAGE WEEKDAY SPEED DISTRIBUTIONS, WESTERN SECTION

FIGURE 4-AD

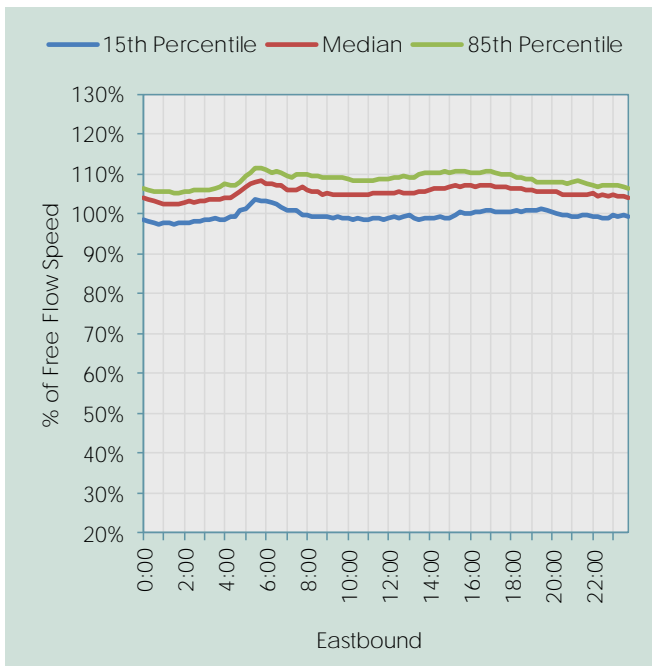
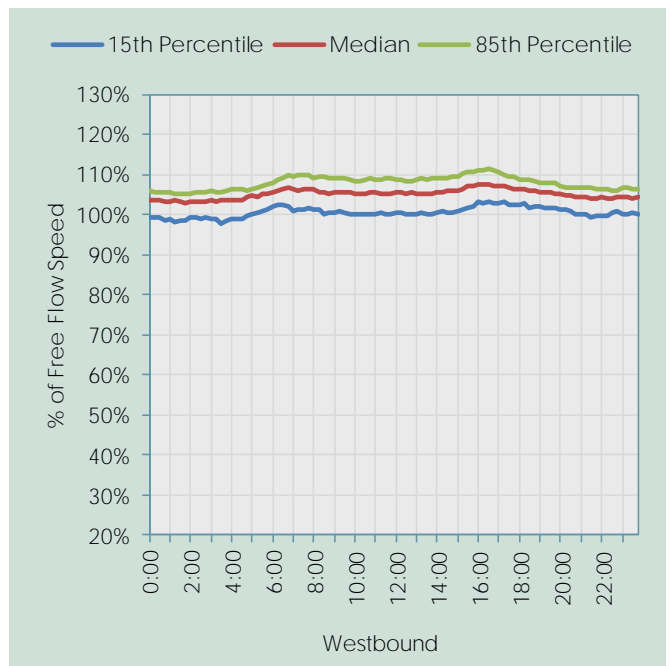
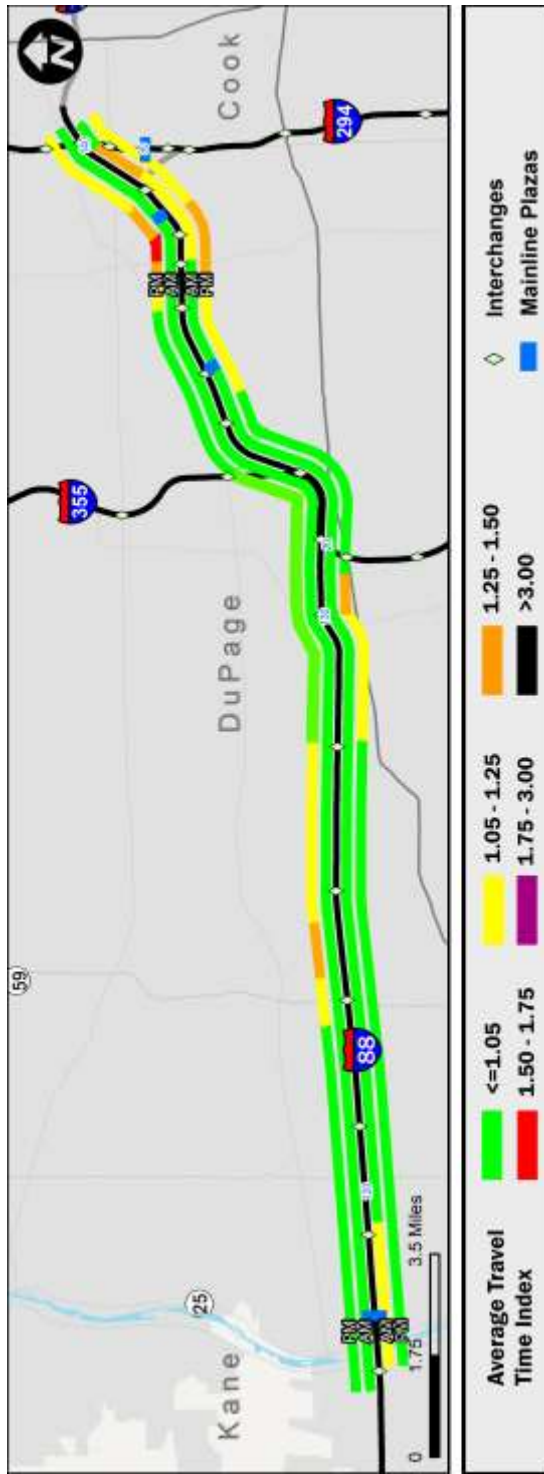

FIGURE 4-AE





Quarter	Range	Average Speed (mph)		Average Travel Time Index		Planning Time Index		Total Delay (veh-hrs / 1000 VMT)		Average Daily Delay (veh-hrs)		Percent Congested Travel	
		AM	PM	AM	PM	AM	PM	AM	PM	AM	PM		
1	January -March	62	58	0.97	1.03	1.08	1.23	0.6	1.5	477	1,024	12	25
2	April-June	61	55	0.99	1.10	1.12	1.35	1.0	2.4	764	1,766	19	36
3	July-September	60	55	0.99	1.08	1.21	1.25	1.0	2.2	767	1,605	18	36
4	October-December	62	55	0.97	1.09	1.08	1.28	0.6	2.3	475	1,628	15	37
Total	2016 Entire Year	61	56	0.98	1.08	1.12	1.28	0.8	2.1	621	1,506	16	33

Data source: INRIX. Roadway performance measures sections and terms are defined on pages 1-4 and 1-5.

FIGURE 4-AF: ROADWAY PERFORMANCE MEASURES—EASTERN SECTION



Quarter	Range	Average Speed (mph)		Average Travel Time Index		Planning Time Index		Total Delay (veh-hrs / 1000 VMT)		Average Daily Delay (veh-hrs)		Percent Congested Travel	
		AM	PM	AM	PM	AM	PM	AM	PM	AM	PM		
1	January - March	66	66	0.91	0.91	0.95	0.94	0.0	0.0	8	15	1	2
2	April - June	63	63	0.95	0.95	1.01	1.01	0.4	0.4	95	119	21	23
3	July - September	65	65	0.93	0.92	0.96	0.95	0.2	0.1	41	41	8	8
4	October - December	65	65	0.92	0.92	0.95	0.95	0.1	0.1	27	32	6	7
Total	2016 Entire Year	65	65	0.93	0.93	0.97	0.96	0.2	0.2	43	52	9	10

Data source: INRIX. Roadway performance measures sections and terms are defined on pages 1-4 and 1-5.

FIGURE 4-AG: ROADWAY PERFORMANCE MEASURES—WESTERN SECTION

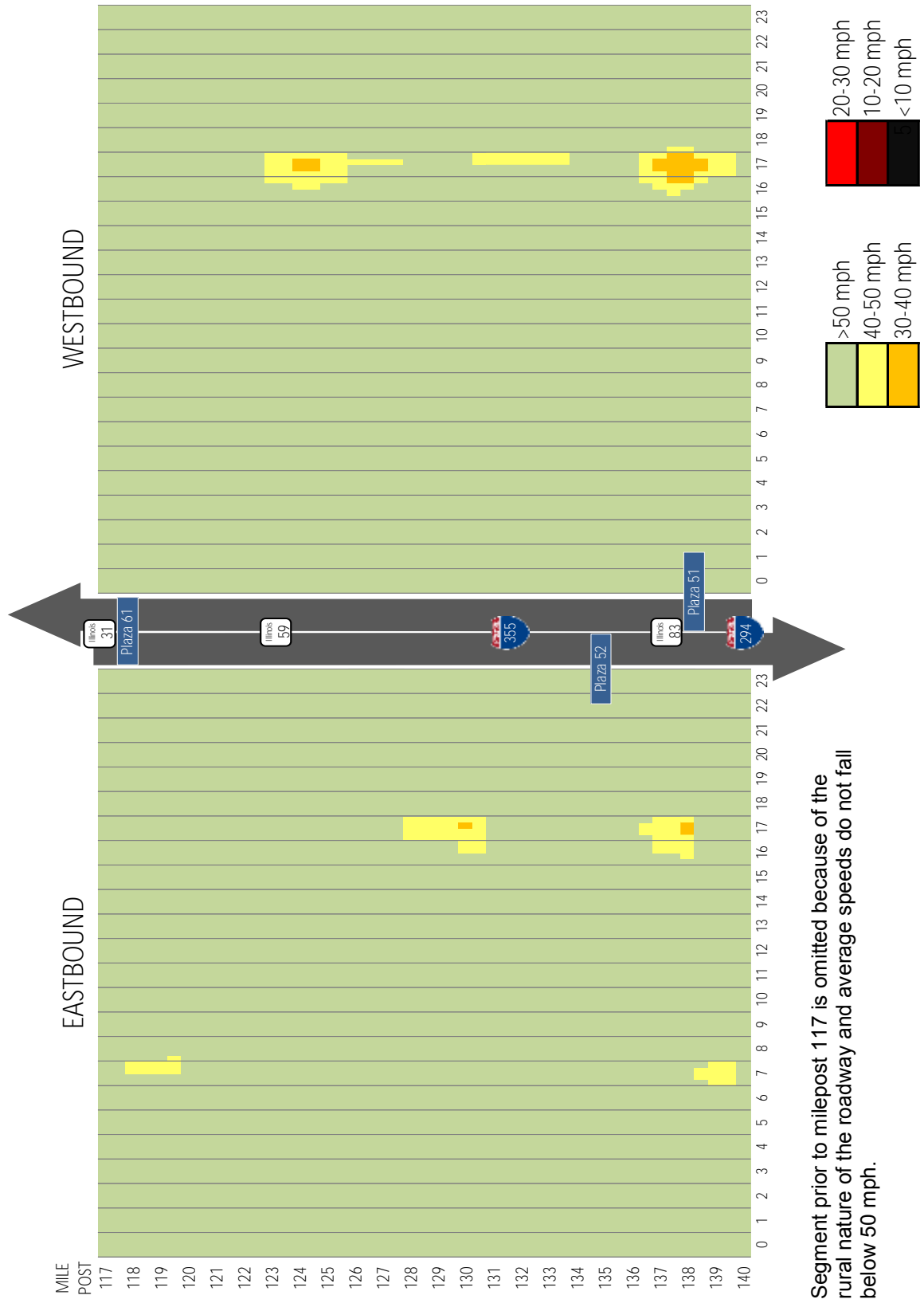

Segment prior to milepost 117 is omitted because of the rural nature of the roadway and average speeds do not fall below 50 mph.

FIGURE 4-AH: AVERAGE SPEED CONTOURS, MP 117.0 TO 140.0



This Page Is Intentionally Left Blank



Section 5

Veterans Memorial Tollway



SECTION 5

Veterans Memorial Tollway

TABULATIONS TABLE

	PAGE
5-A Average Daily Traffic Volumes Between interchanges 1980 – 2016 (Northbound)	5-4
5-B Average Daily Traffic Volumes Between Interchanges 1980 – 2016 (Southbound)	5-5
5-C General Statistics for Mainline Plazas	5-6
5-D Indexed Monthly Variation by Mainline Plaza	5-7
5-E Indexed Daily Variation by Mainline Plaza	5-7
5-F Annual Total Transactions by Toll Plaza	5-8
5-G Average Daily Traffic Data	5-9

ILLUSTRATIONS FIGURE

	PAGE
5-A Mainline Plaza Highest Hourly Volume Plaza 73 NB	5-10
5-B Mainline Plaza Highest Hourly Volume Plaza 73 SB	5-10
5-C Mainline Plaza Highest Hourly Volume Plaza 89 NB	5-10
5-D Mainline Plaza Highest Hourly Volume Plaza 89 SB	5-10
5-E Mainline Plaza Highest Hourly Volume Plaza 99 NB	5-11
5-F Mainline Plaza Highest Hourly Volume Plaza 99 SB	5-11
5-G Average Daily Traffic Trends Plaza 73 Army Trail Road	5-12
5-H Average Daily Traffic Trends Plaza 75 North Avenue	5-12
5-I Average Daily Traffic Trends Plaza 77 Roosevelt Road	5-12
5-J Average Daily Traffic Trends Plaza 79 Butterfield Road	5-13
5-K Average Daily Traffic Trends Plaza 81 Ogden Avenue	5-13
5-L Average Daily Traffic Trends Plaza 83 Maple Avenue	5-13
5-M Average Daily Traffic Trends Plaza 85 63rd Street	5-14
5-N Average Daily Traffic Trends Plaza 87 75th Street	5-14
5-O Average Daily Traffic Trends Plaza 89 Boughton Road	5-14
5-P Average Daily Traffic Trends Plaza 90 Boughton Road Ramp	5-15
5-Q Average Daily Traffic Trends Plaza 93 127th Street	5-15
5-R Average Daily Traffic Trends Plaza 95 Archer Avenue/143rd Street	5-15
5-S Average Daily Traffic Trends Plaza 97 Illinois Route 7	5-16
5-T Average Daily Traffic Trends Plaza 99 Spring Creek	5-16
5-U Average Daily Traffic Trends Plaza 101 U.S. Route 6	5-16
5-V Average Weekday Speed Distributions, Northern Section—Northbound	5-17
5-W Average Weekday Speed Distributions, Northern Section—Southbound	5-17
5-X Average Weekday Speed Distributions, Central Section—Northbound	5-17
5-Y Average Weekday Speed Distributions, Central Section—Southbound	5-17



SECTION 5 Veterans Memorial Tollway

ILLUSTRATIONS (CONTINUED) FIGURE

PAGE

5-Z	Average Weekday Speed Distributions, Southern Section—Northbound	5-18
5-AA	Average Weekday Speed Distributions, Southern Section—Southbound	5-18
5-AB	Roadway Performance Measures, Northern Section	5-19
5-AC	Roadway Performance Measures, Central Section	5-20
5-AD	Roadway Performance Measures, Southern Section	5-21
5-AE	Average Speed Contours, MP 1.5 to 29.5	5-22



This Page Is Intentionally Left Blank



TABLE 5-A: AVERAGE DAILY TRAFFIC VOLUMES BETWEEN INTERCHANGES 1980-2016 (NORTHBOUND)

Location	Mile Post	Miles Btwn. Int.	ADT 1980	Average Annual Percent Change	ADT 1990	Average Annual Percent Change	ADT 2000	Average Annual Percent Change	ADT 2010	Average Annual Percent Change	ADT 2016
Illinois Route 53 & Army Trail Road	29.8										
Toll Plaza 73	29.2	1.9	N/A	-	27,490	6.0	49,080	1.0	54,050	1.0	57,280
North Avenue (PL75)	27.9										
		3.3	N/A	-	31,630	6.0	56,870	0.6	60,470	1.1	64,530
Roosevelt Road (PL77)	24.6										
		2.0	N/A	-	29,970	6.5	56,450	0.6	60,120	1.3	64,920
Butterfield Road (PL79)	22.6										
		1.1	N/A	-	29,130	6.8	56,210	0.9	61,400	1.2	65,950
Reagan Memorial Tollway (E. Int)	21.5										
		2.0	N/A	-	15,330	6.5	28,880	2.1	35,650	3.0	42,610
Ogden Avenue (PL81)	19.5										
		0.4	N/A	-	18,180	2.8	23,900	5.0	38,930	2.1	44,190
Reagan Memorial Tollway (W. Int)	19.1										
		1.2	N/A	-	29,390	6.4	54,880	2.4	69,230	1.8	77,250
Maple Avenue (PL83)	18.3										
		1.1	N/A	-	28,390	6.2	52,010	2.5	66,260	2.0	74,630
63rd Street (PL85)	17.2										
		1.7	N/A	-	25,150	6.2	45,820	2.8	60,440	2.0	68,110
75th Street (PL87)	15.5										
Toll Plaza 89	14.4	1.7	N/A	-	20,320	6.7	38,860	3.8	56,660	1.9	63,350
Boughton Road (PL90)	13.8										
		1.5	N/A	-	16,490	7.3	33,470	4.8	53,640	2.1	60,890
I-55	12.3										
		3.4	N/A	-	N/A	-	N/A	-	33,830	2.7	39,700
127th Street (PL93)	8.9										
		1.6	N/A	-	N/A	-	N/A	-	31,670	3.0	37,750
Archer Avenue/143rd Street (PL95)	7.3										
		2.5	N/A	-	N/A	-	N/A	-	28,690	2.9	34,110
Illinois Route 7/159th Street (PL97)	4.8										
Toll Plaza 99	3.3	4.0	N/A	-	N/A	-	N/A	-	23,480	3.7	29,260
U.S. Route 6 (PL101)	0.8										
		0.8	N/A	-	N/A	-	N/A	-	18,960	4.4	24,500
I-80	0.0										



TABLE 5-B: AVERAGE DAILY TRAFFIC VOLUMES BETWEEN INTERCHANGES 1980-2016 (SOUTHBOUND)

Location	Mile Post	Miles Btwn. Int.	ADT 1980	Average Annual Percent Change	ADT 1990	Average Annual Percent Change	ADT 2000	Average Annual Percent Change	ADT 2010	Average Annual Percent Change	ADT 2016
Illinois Route 53 & Army Trail Road	29.8										
Toll Plaza 73	29.2	1.9	N/A	-	27,380	6.2	49,870	0.8	54,110	1.2	58,080
North Avenue (PL75)	27.9										
		3.3	N/A	-	31,280	6.4	58,060	0.4	60,560	1.2	65,020
Roosevelt Road (PL77)	24.6										
		2.0	N/A	-	29,340	6.9	56,940	0.8	61,360	1.3	66,110
Butterfield Road (PL79)	22.6										
		1.1	N/A	-	28,420	7.1	56,520	0.9	61,900	1.6	67,910
Reagan Memorial Tollway (E. Int)	21.5										
		1.4	N/A	-	24,240	7.1	48,220	1.3	55,070	1.4	59,720
Reagan Memorial Tollway (W. Int)	20.1										
		0.6	N/A	-	26,770	6.8	51,540	2.0	62,870	2.2	71,710
Ogden Avenue (PL81)	19.5										
		1.2	N/A	-	29,410	6.6	55,680	2.2	69,140	1.8	77,140
Maple Avenue (PL83)	18.3										
		1.1	N/A	-	28,600	6.3	52,680	2.4	66,600	1.8	74,300
63rd Street (PL85)	17.2										
		1.7	N/A	-	25,390	6.3	46,870	2.6	60,820	1.8	67,850
75th Street (PL87)	15.5										
Toll Plaza 89	14.4	1.7	N/A	-	20,530	6.8	39,640	3.8	57,420	1.6	62,990
Boughton Road (PL90)	13.8										
		1.5	N/A	-	16,740	7.3	33,900	5.1	55,790	1.8	62,210
I-55	12.3										
		3.4	N/A	-	N/A	-	N/A	-	33,800	2.5	39,210
127th Street (PL93)	8.9										
		1.6	N/A	-	N/A	-	N/A	-	31,350	2.7	36,680
Archer Avenue/143rd Street (PL95)	7.3										
		2.5	N/A	-	N/A	-	N/A	-	28,660	2.6	33,360
Illinois Route 7/159th Street (PL97)	4.8										
Toll Plaza 99	3.3	4.0	N/A	-	N/A	-	N/A	-	23,530	3.2	28,370
U.S. Route 6 (PL101)	0.8										
		0.8	N/A	-	N/A	-	N/A	-	18,410	3.7	22,940
I-80	0.0										



**TABLE 5-C: GENERAL STATISTICS FOR MAINLINE PLAZAS
(Vehicles/Hour)**

Mainline Plaza	Dir.	30th HV	Period	Mean	Med.	Max.	Min.	Std. Dev.	85th %
73 Army Trail Road	NB	5,864	AM Peak	5,347	5,428	6,174	3,314	433	5,740
			PM Peak	4,966	5,006	5,556	3,589	298	5,245
			OFF Peak	2,120	2,300	5,381	108	1,454	3,670
			Weekend	2,112	2,120	5,754	119	1,411	3,483
			Holidays	1,840	1,811	5,180	99	1,312	3,294
	SB	5,970	AM Peak	4,461	3,920	5,941	2,467	980	5,587
			PM Peak	5,387	5,416	6,283	4,310	383	5,740
			OFF Peak	2,232	2,185	5,999	91	1,648	4,249
			Weekend	2,118	2,046	6,108	123	1,454	3,479
			Holidays	1,851	1,746	5,112	100	1,346	3,309
89 Boughton Road	NB	6,892	AM Peak	6,331	6,385	7,088	4,457	480	6,789
			PM Peak	4,467	4,484	5,121	3,477	319	4,792
			OFF Peak	2,316	2,570	5,594	145	1,564	3,998
			Weekend	2,426	2,432	6,563	178	1,577	3,972
			Holidays	2,140	2,084	6,199	146	1,480	3,758
	SB	6,927	AM Peak	3,463	3,326	4,348	2,162	540	4,075
			PM Peak	6,337	6,332	7,223	5,176	412	6,758
			OFF Peak	2,422	2,604	6,590	137	1,708	4,078
			Weekend	2,386	2,380	7,045	177	1,586	3,872
			Holidays	2,104	1,998	6,237	138	1,496	3,611
99 Spring Creek	NB	3,704	AM Peak	3,262	3,291	3,886	2,142	323	3,574
			PM Peak	2,112	2,125	2,463	1,080	180	2,284
			OFF Peak	1,053	1,150	2,900	68	722	1,783
			Weekend	1,097	1,102	3,443	71	729	1,765
			Holidays	990	939	2,975	44	705	1,728
	SB	3,182	AM Peak	1,801	1,705	2,357	1,137	318	2,175
			PM Peak	2,879	2,897	3,293	2,406	199	3,049
			OFF Peak	1,068	1,056	3,099	61	761	1,924
			Weekend	1,070	1,032	3,523	59	739	1,783
			Holidays	957	857	2,992	46	720	1,718

AM Peak = Weekday 6:00 AM To 8:00 AM Except Fridays
 PM Peak = Weekday 4:00 PM To 6:00 PM Except Fridays
 OFF Peak = Weekdays Except Fridays and AM and PM Peak Periods
 Weekend = Fridays, Saturdays, and Sundays
 Holidays = See Page 1-6 for a list of Holidays.



TABLE 5-D: INDEXED MONTHLY VARIATION BY MAINLINE PLAZA

Month	Army Trail Road	Boughton Road	Spring Creek
January	0.90	0.88	0.86
February	0.95	0.94	0.91
March	1.00	0.99	0.96
April	1.01	1.01	0.99
May	1.03	1.04	1.03
June	1.08	1.08	1.09
July	1.02	1.03	1.05
August	1.05	1.05	1.06
September	1.03	1.03	1.06
October	1.01	1.02	1.03
November	0.99	0.99	1.02
December	0.93	0.94	0.94

TABLE 5-E: INDEXED DAILY VARIATION BY MAINLINE PLAZA

Month	Day	Army Trail Road	Boughton Road	Spring Creek
August	Monday	1.06	1.06	1.08
	Tuesday	1.03	1.03	1.04
	Wednesday	1.03	1.04	1.04
	Thursday	1.04	1.04	1.04
	Friday	1.04	1.04	1.05
	Saturday	1.03	1.03	1.06
	Sunday	1.07	1.06	1.07
December	Monday	0.89	0.91	0.92
	Tuesday	0.97	0.98	0.99
	Wednesday	0.98	0.99	1.00
	Thursday	0.96	0.98	0.98
	Friday	0.93	0.94	0.94
	Saturday	0.89	0.89	0.87
	Sunday	0.83	0.82	0.82

Table 5-E includes Monthly Variation



TABLE 5-F: ANNUAL TOTAL TRANSACTIONS BY TOLL PLAZA

Plaza	Plaza Code*	2015	2016	Percentage Change
73 Army Trail Road	M	41,731,195	42,224,196	1.2%
75 North Avenue	R	10,762,817	10,930,453	1.6%
77 Roosevelt Road	R	5,887,525	6,038,953	2.6%
79 Butterfield Road	R	6,194,982	6,416,918	3.6%
81 Ogden Avenue	R	1,664,657	1,753,405	5.3%
83 Maple Avenue	R	4,460,278	4,515,418	1.2%
85 63rd Street	R	6,279,234	6,251,436	-0.4%
87 75th Street	R	6,279,871	6,239,898	-0.6%
89 Boughton Mainline	M	45,224,041	46,241,688	2.3%
90 Boughton Road	R	4,809,764	4,772,550	-0.8%
93 127th Street	R	2,484,908	2,567,756	3.3%
95 Archer Avenue	R	3,513,053	3,759,350	7.0%
97 Route 7	R	5,164,687	4,979,678	-3.6%
99 Spring Creek	M	20,251,530	21,094,920	4.2%
101 U.S. Route 6	R	1,675,593	1,799,977	7.4%
Veterans Memorial Total		166,384,135	169,586,596	1.9%

* M=Mainline / R=Ramp / A=Attended Ramp Plaza / E=Electronic Toll Collection Only Ramp
1=Toll Collected in One Direction Only



TABLE 5-G: AVERAGE DAILY TRAFFIC DATA

Year	Average Daily Total			Average Trip
	Vehicles	Vehicle Miles	Transactions	Length (Miles)
1989	1,718	18,733	2,794	10.90
1990	116,106	913,325	148,394	7.87
1991	112,664	1,080,313	177,384	9.59
1992	125,446	1,203,491	198,723	9.59
1993	133,101	1,280,823	211,525	9.62
1994	135,381	1,297,315	214,764	9.58
1995	136,250	1,324,254	219,397	9.72
1996	140,780	1,397,726	230,871	9.93
1997	149,430	1,481,389	240,479	9.91
1998	153,670	1,524,455	253,551	9.92
1999	162,950	1,578,153	267,579	9.68
2000	174,040	1,712,671	281,509	9.84
2001	184,280	1,820,705	297,086	9.88
2002	192,155	1,916,090	313,813	9.97
2003	193,150	1,940,636	316,557	10.05
2004	202,630	2,006,635	329,275	9.90
2005	199,310	1,953,866	321,209	9.80
2006	205,210	1,972,819	327,759	9.61
2007	212,000	2,007,320	335,879	9.47
2008	248,120	2,705,470	418,865	10.90
2009	251,180	2,783,566	428,534	11.08
2010	246,290	2,740,256	425,576	11.13
2011	253,630	2,845,902	442,475	11.22
2012	245,530	2,767,855	425,669	11.27
2013	257,920	2,778,398	426,939	10.77
2014	260,710	2,863,237	435,932	10.98
2015	276,290	3,010,917	455,847	10.90
2016	279,120	3,089,715	463,351	11.07

The South Extension to the Veterans Memorial Tollway opened in 2007.



FIGURE 5-A

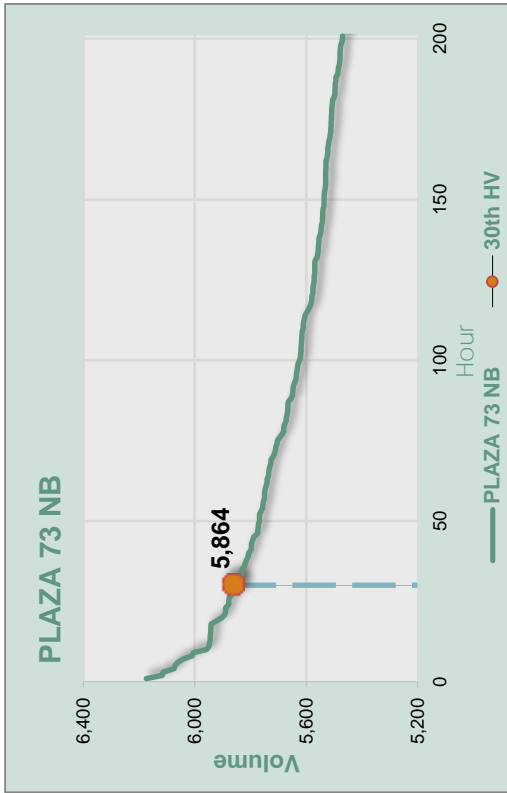

FIGURE 5-B

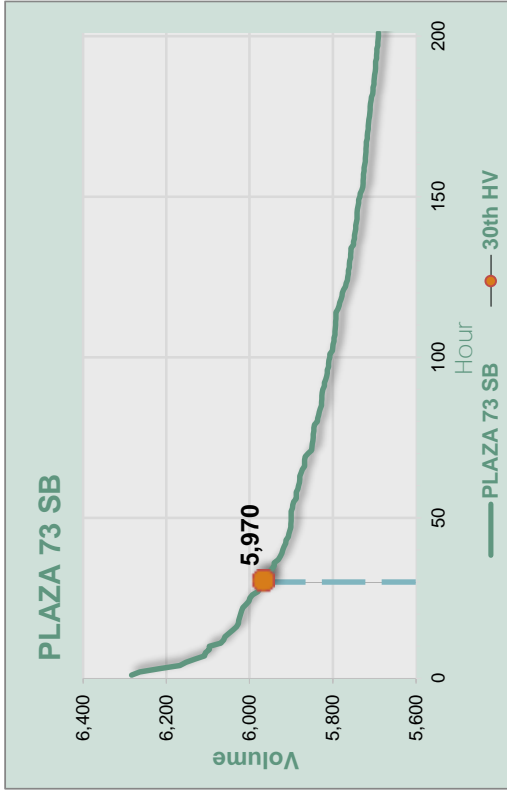

FIGURE 5-C

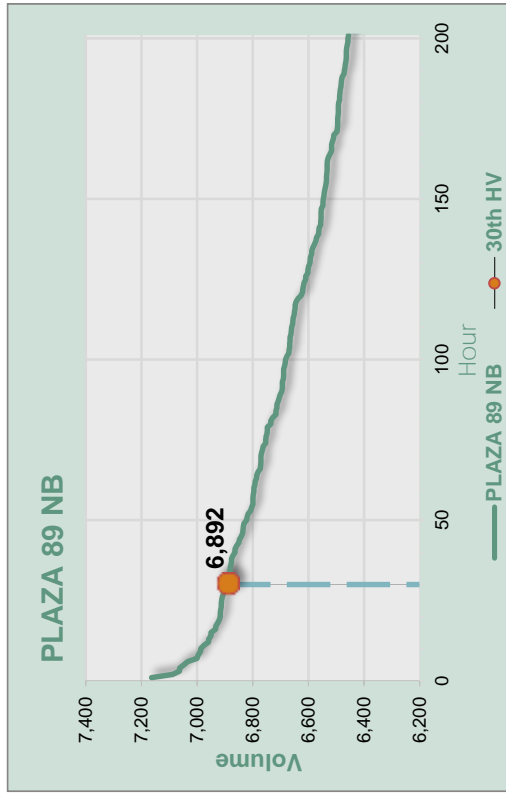
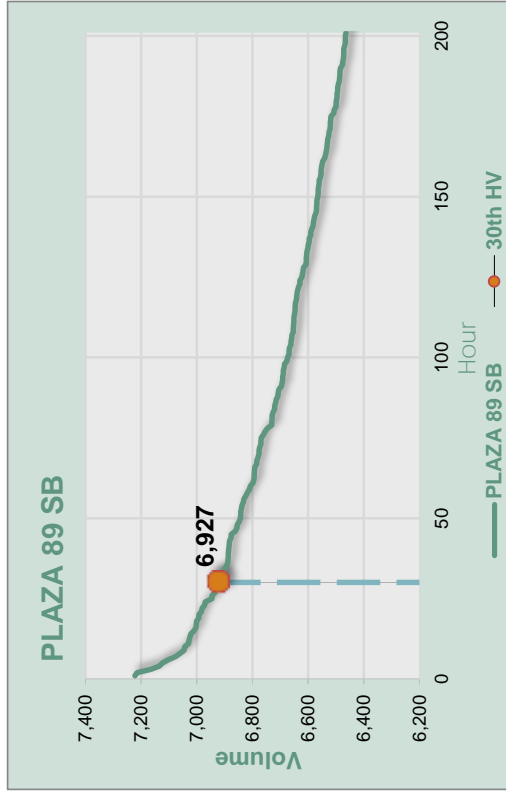

FIGURE 5-D



MAINLINE PLAZA HIGHEST HOURLY VOLUME



FIGURE 5-F

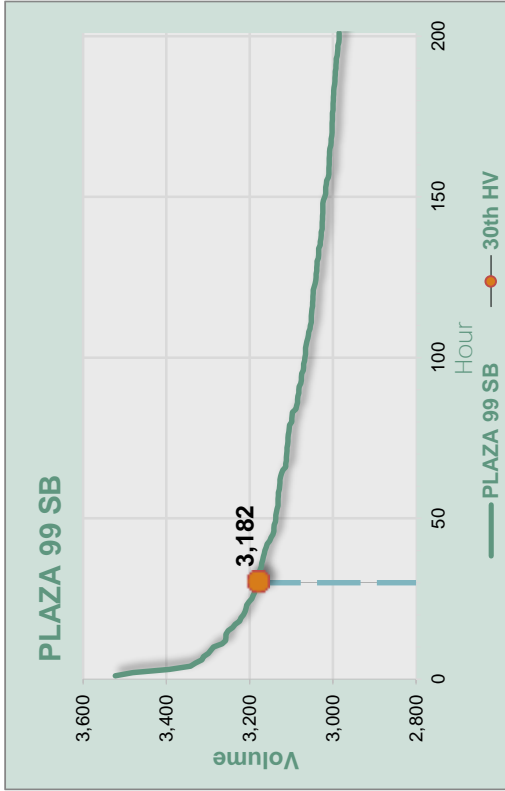
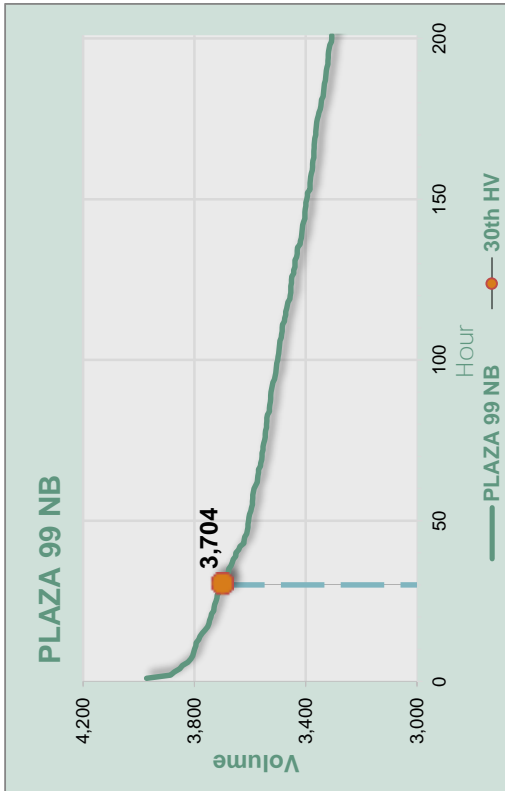

FIGURE 5-E



MAINLINE PLAZA HIGHEST HOURLY VOLUME



FIGURE 5-G

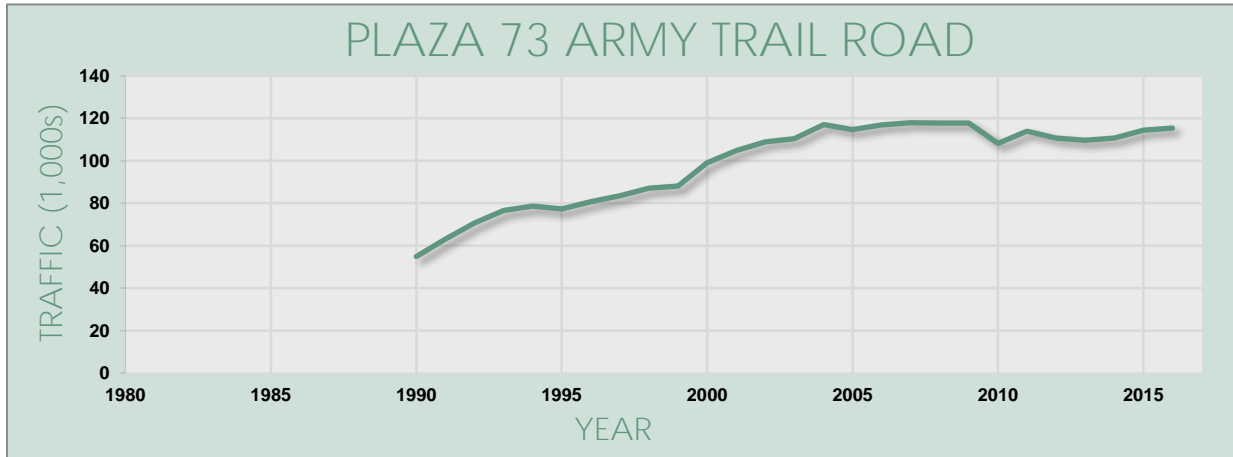

FIGURE 5-H

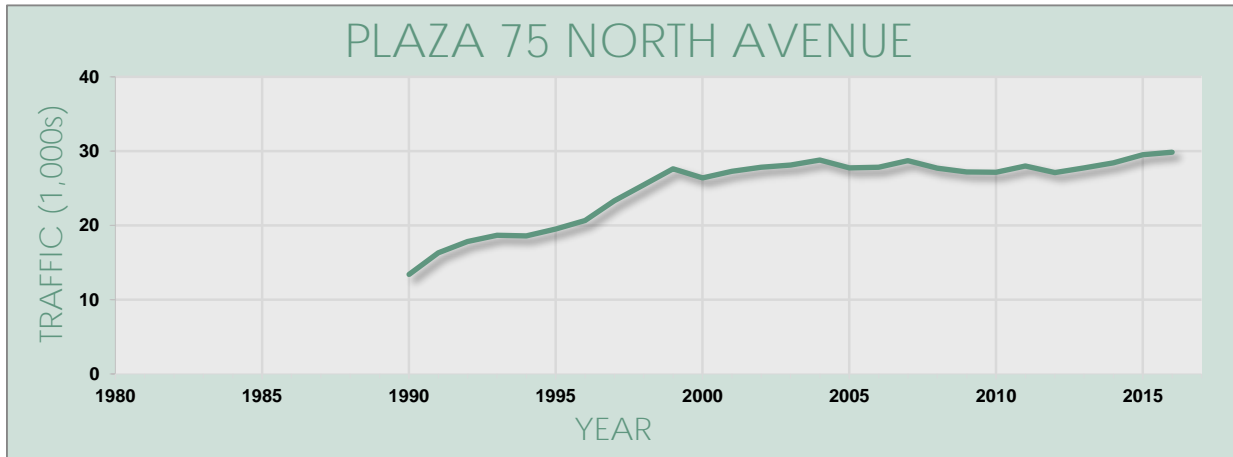
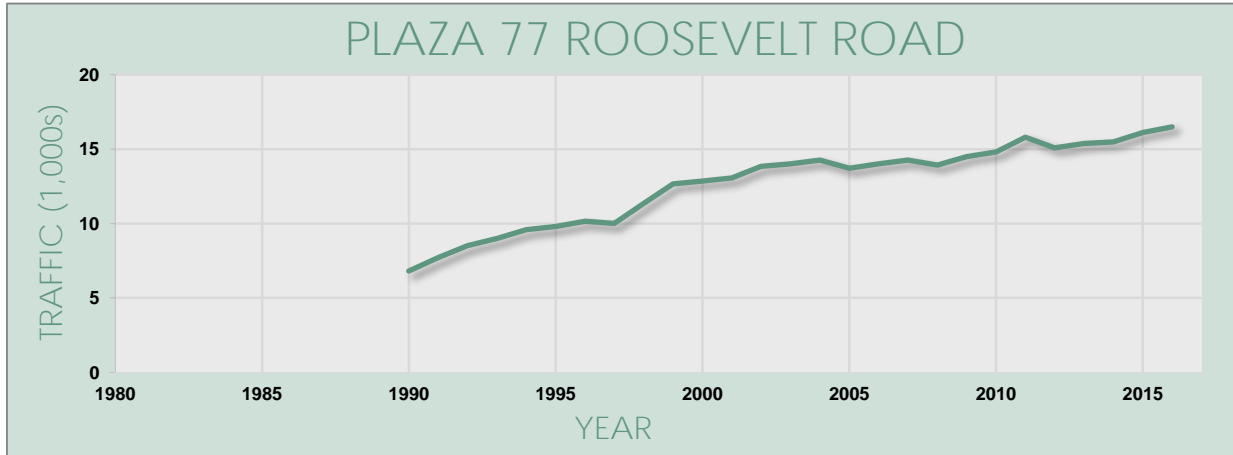

FIGURE 5-I



AVERAGE DAILY TRAFFIC TRENDS



FIGURE 5-J

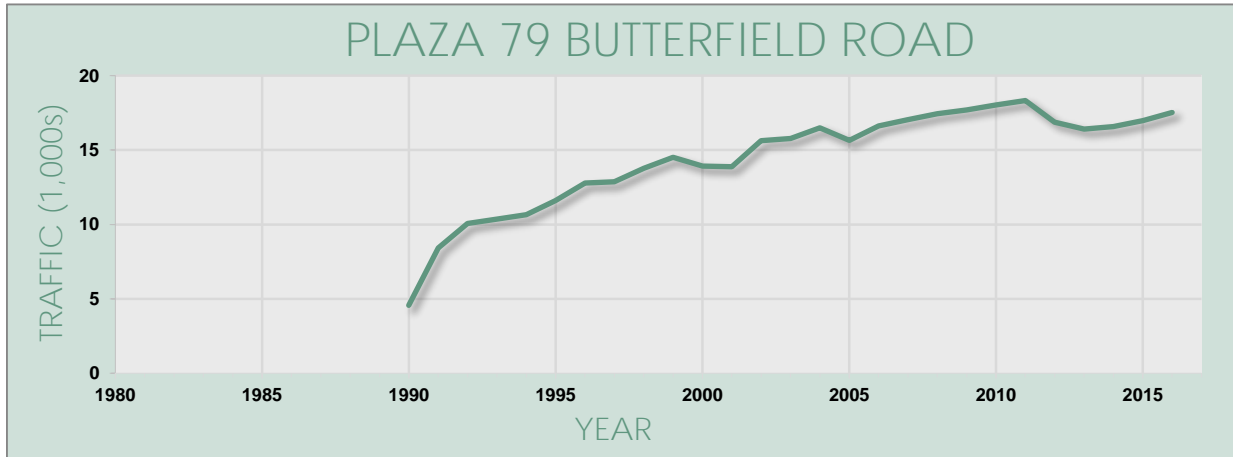

FIGURE 5-K

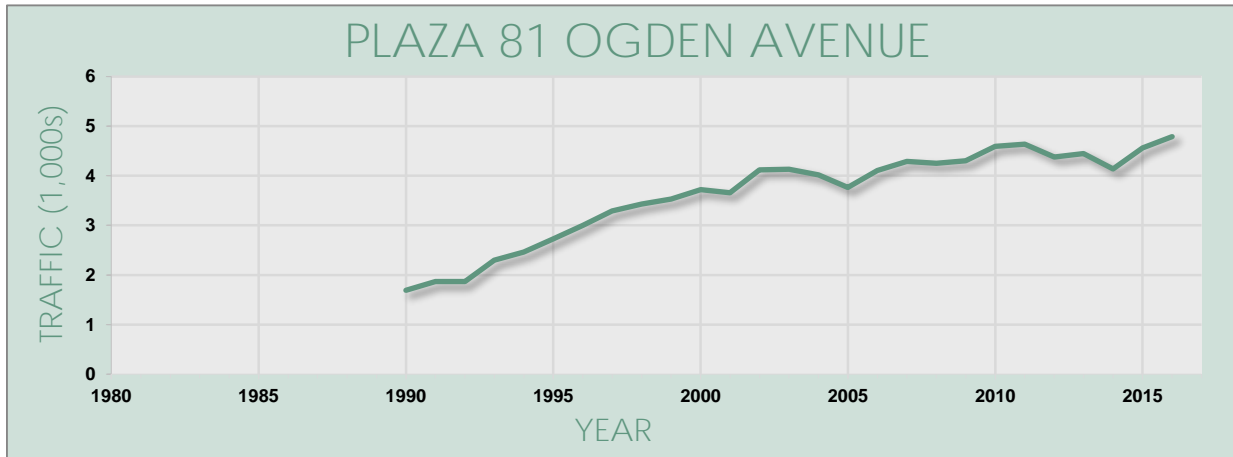
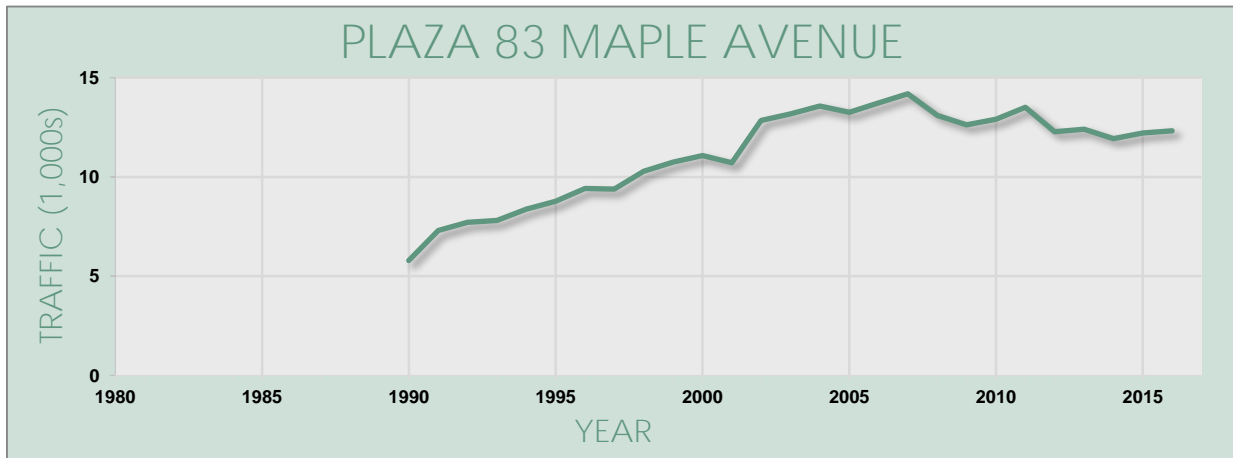

FIGURE 5-L



AVERAGE DAILY TRAFFIC TRENDS



FIGURE 5-M

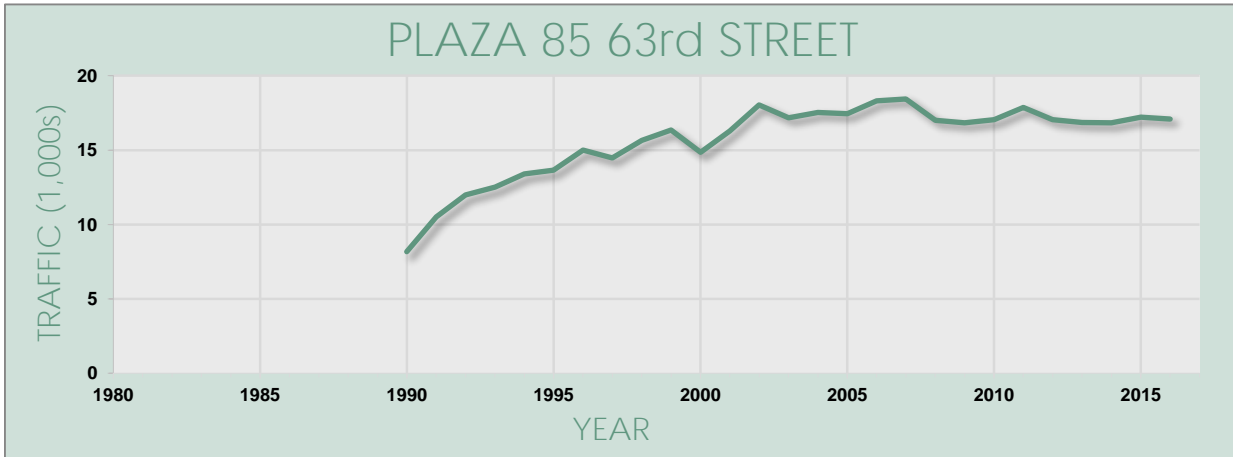

FIGURE 5-N

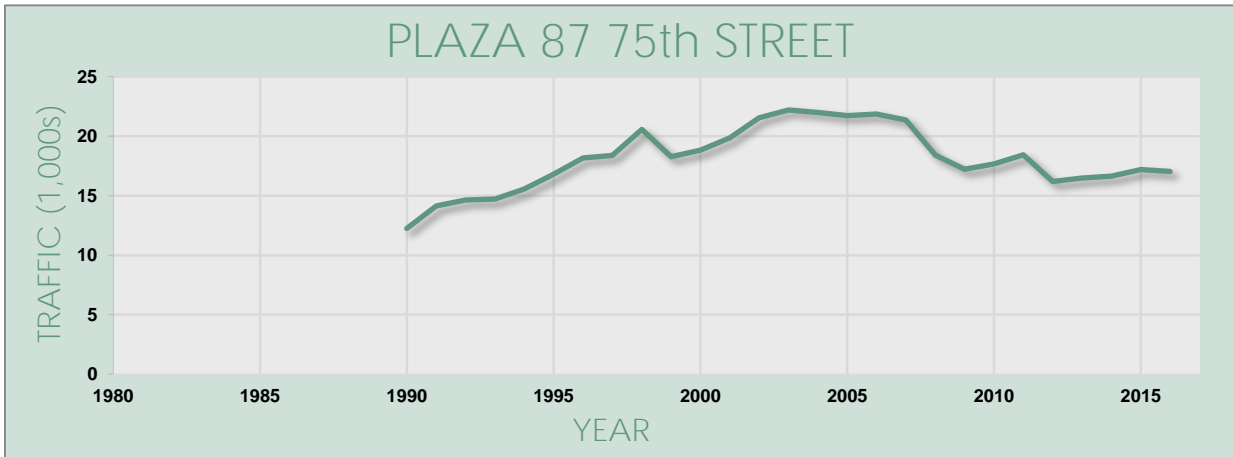
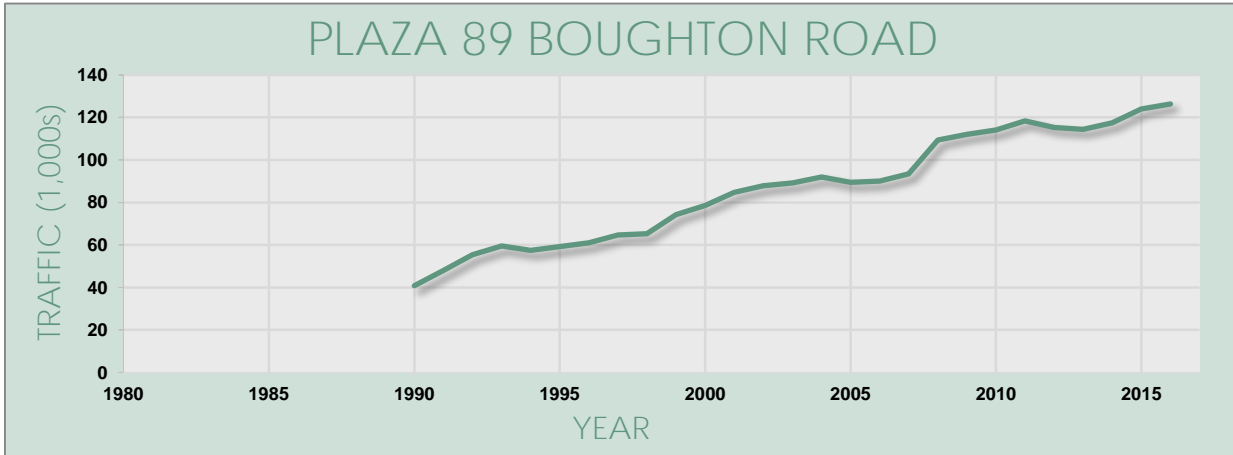

FIGURE 5-O



AVERAGE DAILY TRAFFIC TRENDS



FIGURE 5-P

Plaza 90 opened in 1999.

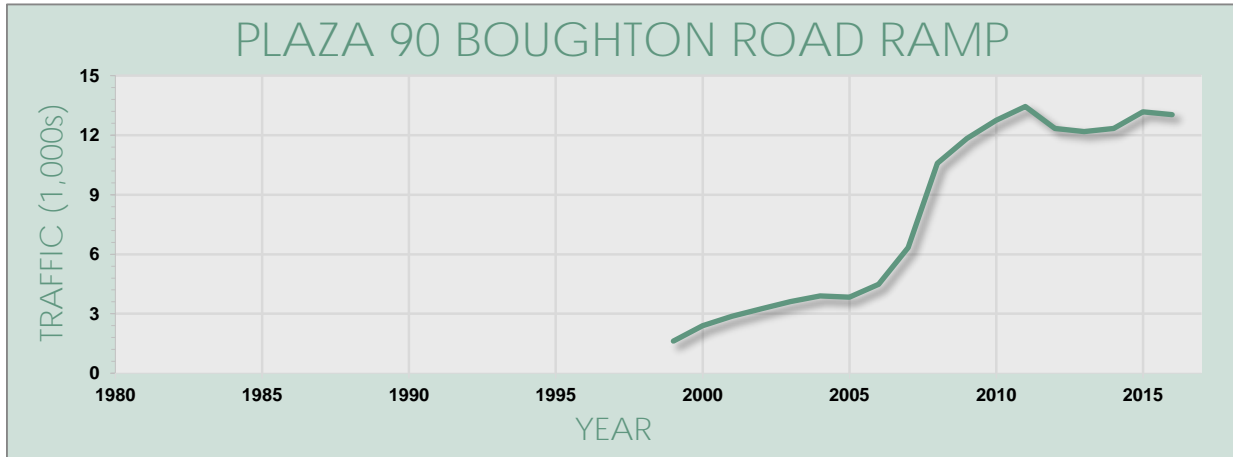

FIGURE 5-Q

The South Extension opened in 2007.

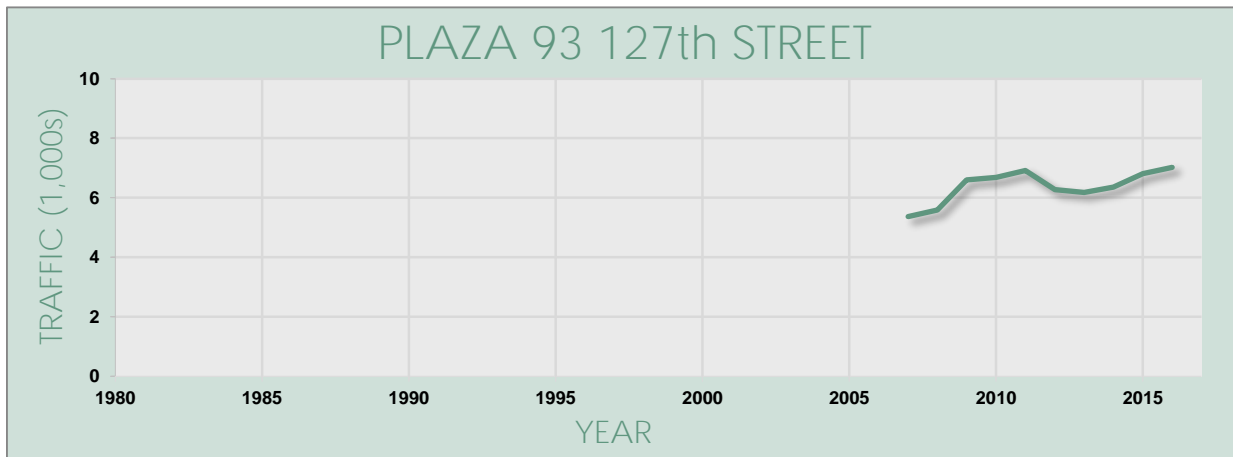
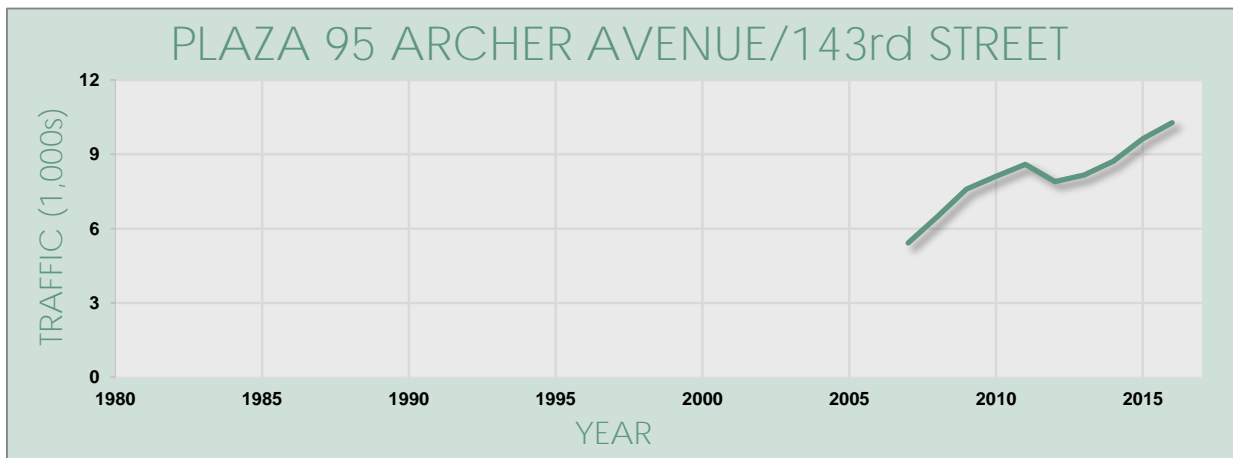

FIGURE 5-R

The South Extension opened in 2007.



AVERAGE DAILY TRAFFIC TRENDS



FIGURE 5-S

The South Extension opened in 2007.

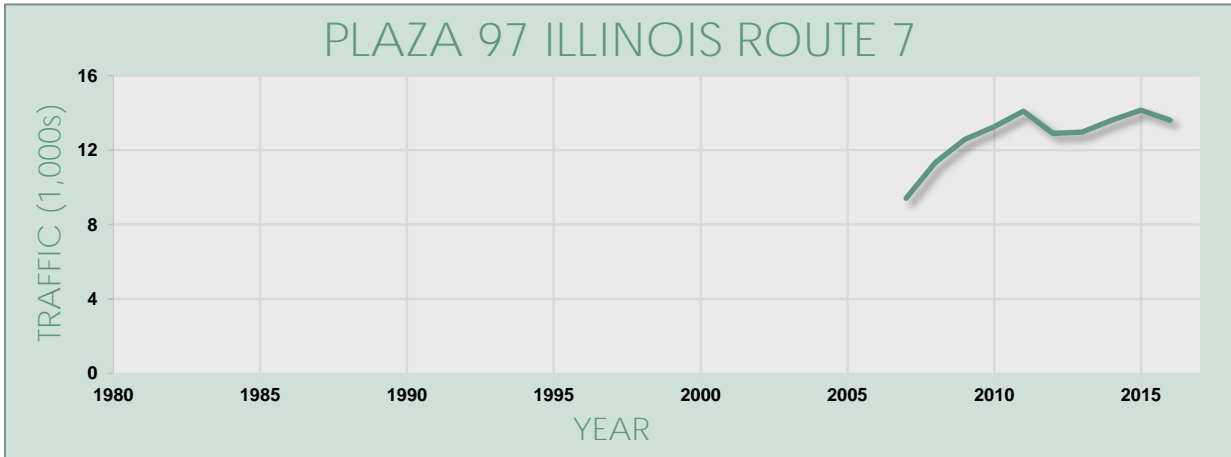

FIGURE 5-T

The South Extension opened in 2007.

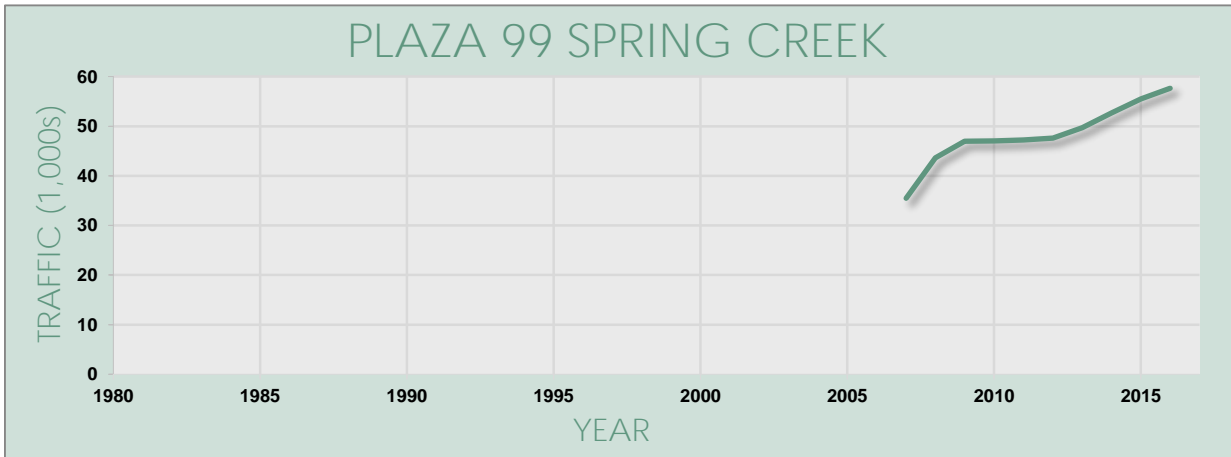
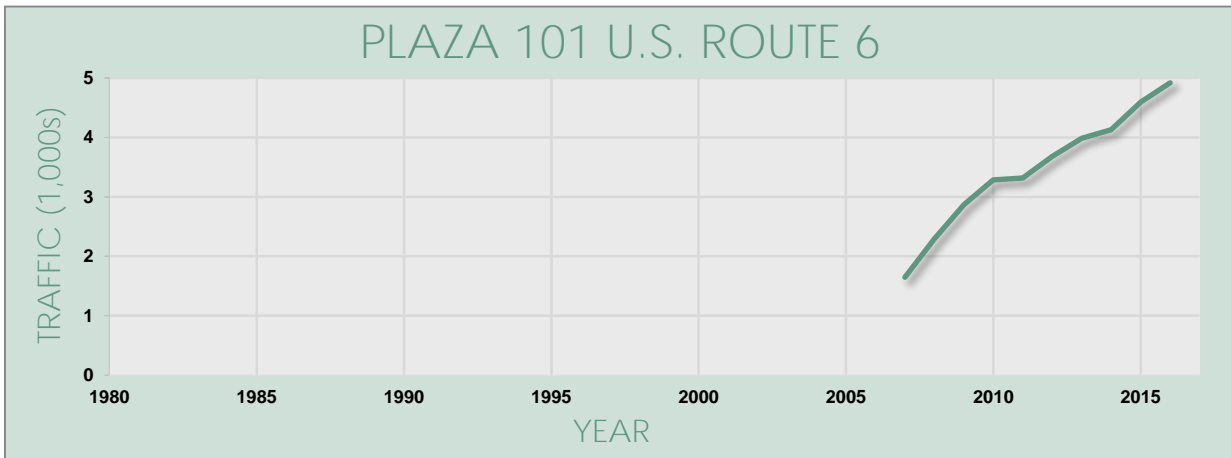

FIGURE 5-U

The South Extension opened in 2007.



AVERAGE DAILY TRAFFIC TRENDS



AVERAGE WEEKDAY SPEED DISTRIBUTIONS, NORTHERN SECTION

FIGURE 5-V

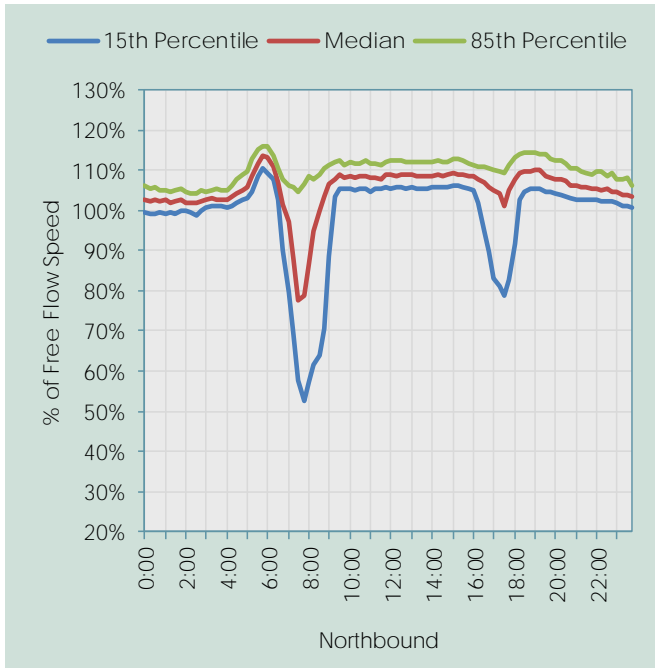
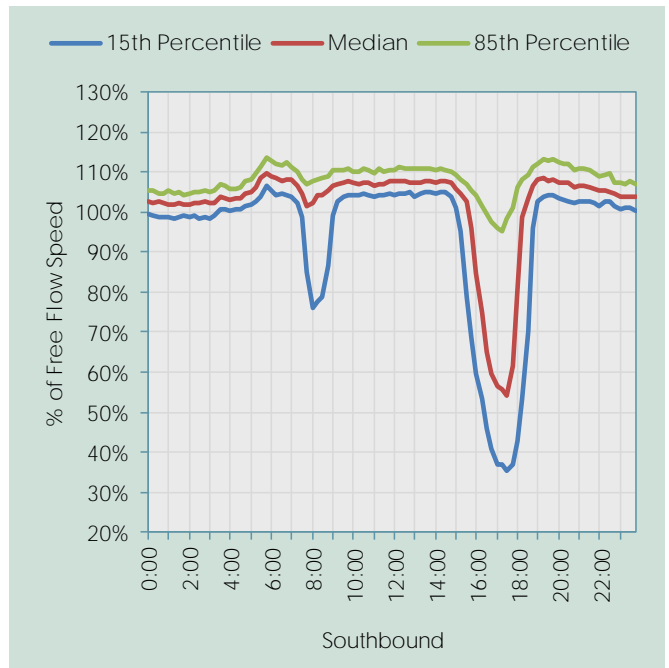

FIGURE 5-W



AVERAGE WEEKDAY SPEED DISTRIBUTIONS, CENTRAL SECTION

FIGURE 5-X

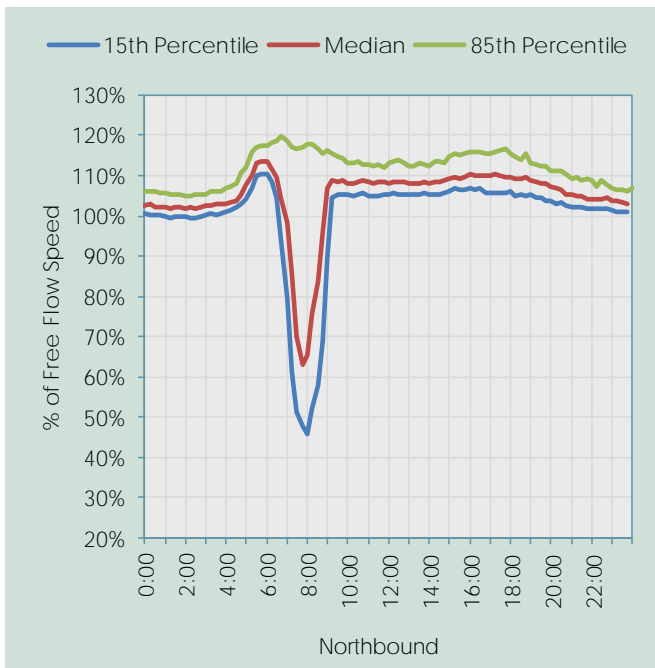
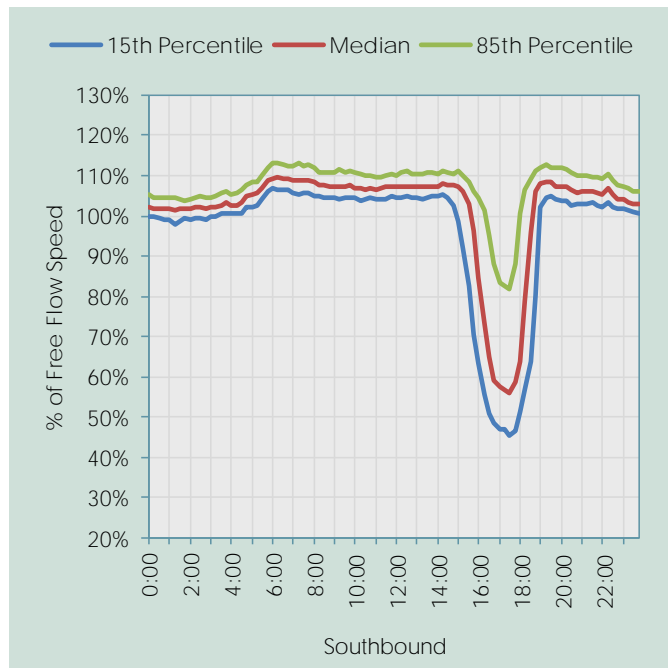

FIGURE 5-Y





AVERAGE WEEKDAY SPEED DISTRIBUTIONS, SOUTHERN SECTION

FIGURE 5-Z

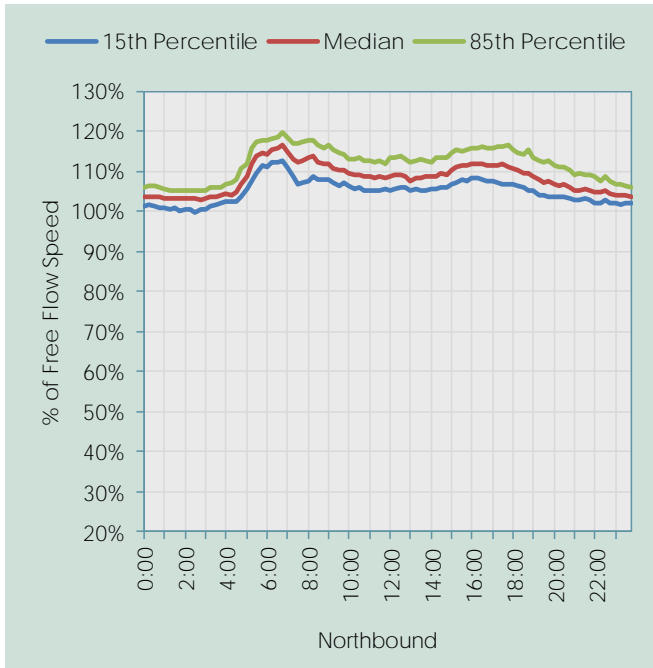
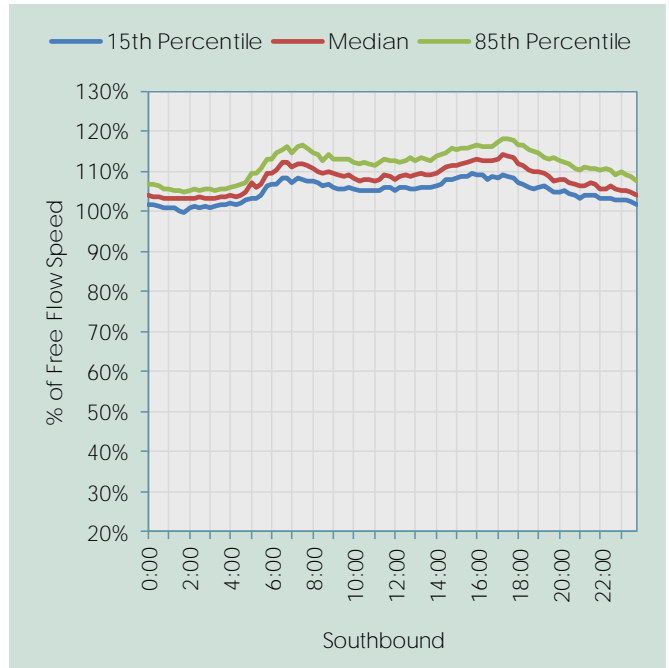
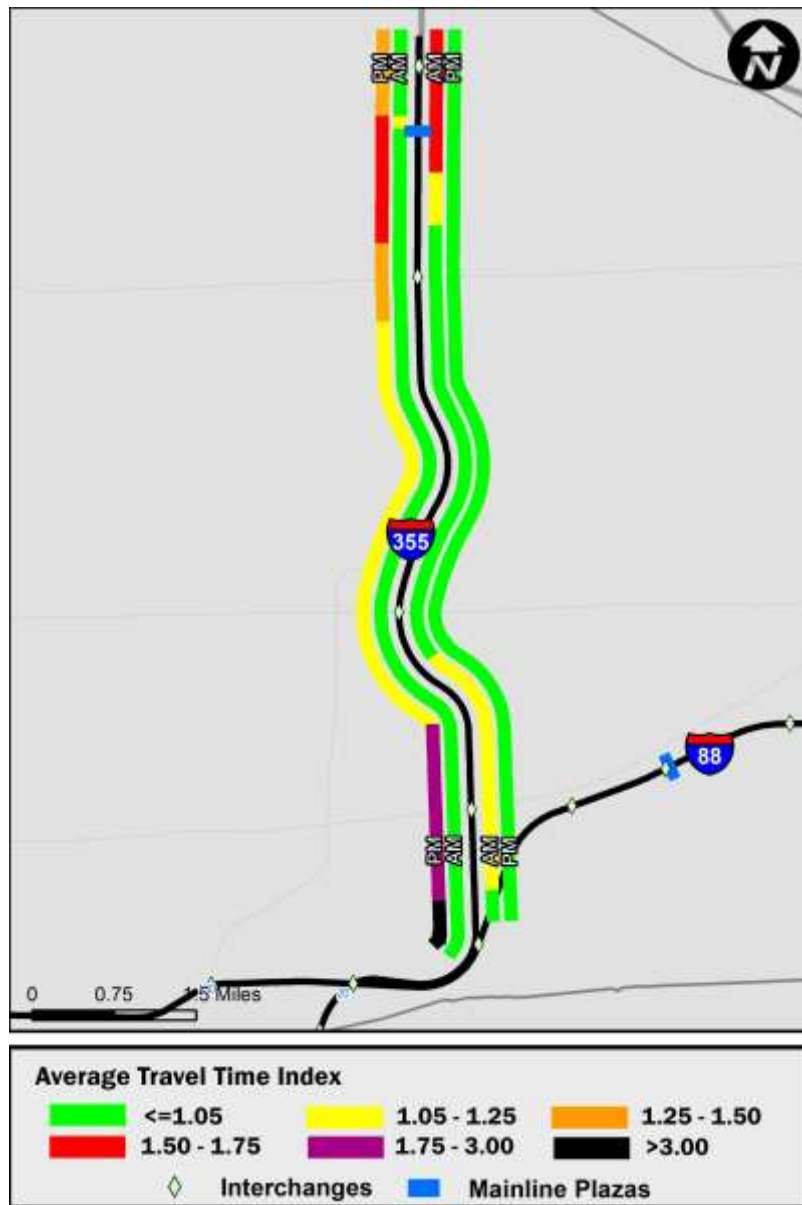

FIGURE 5-AA





Quarter	Range	Average Speed (mph)		Average Travel Time Index		Planning Time Index		Total Delay (veh-hrs / 1000 VMT)		Average Daily Delay (veh-hrs)		Percent Congested Travel	
		AM	PM	AM	PM	AM	PM	AM	PM	AM	PM	AM	PM
1	January -March	59	55	1.01	1.09	1.25	1.33	1.0	2.3	265	567	24	30
2	April-June	55	44	1.09	1.38	1.39	1.75	2.2	6.8	598	1,801	30	56
3	July-September	57	46	1.05	1.31	1.34	1.88	1.7	5.8	430	1,505	25	47
4	October-December	57	48	1.06	1.26	1.21	1.75	1.7	4.9	415	1,223	32	48
Total	2016 Entire Year	57	48	1.05	1.26	1.30	1.67	1.7	5.0	427	1,274	28	45

Data source: INRIX. Roadway performance measures sections and terms are defined on pages 1-4 and 1-5.

FIGURE 5-AB: ROADWAY PERFORMANCE MEASURES—NORTHERN SECTION

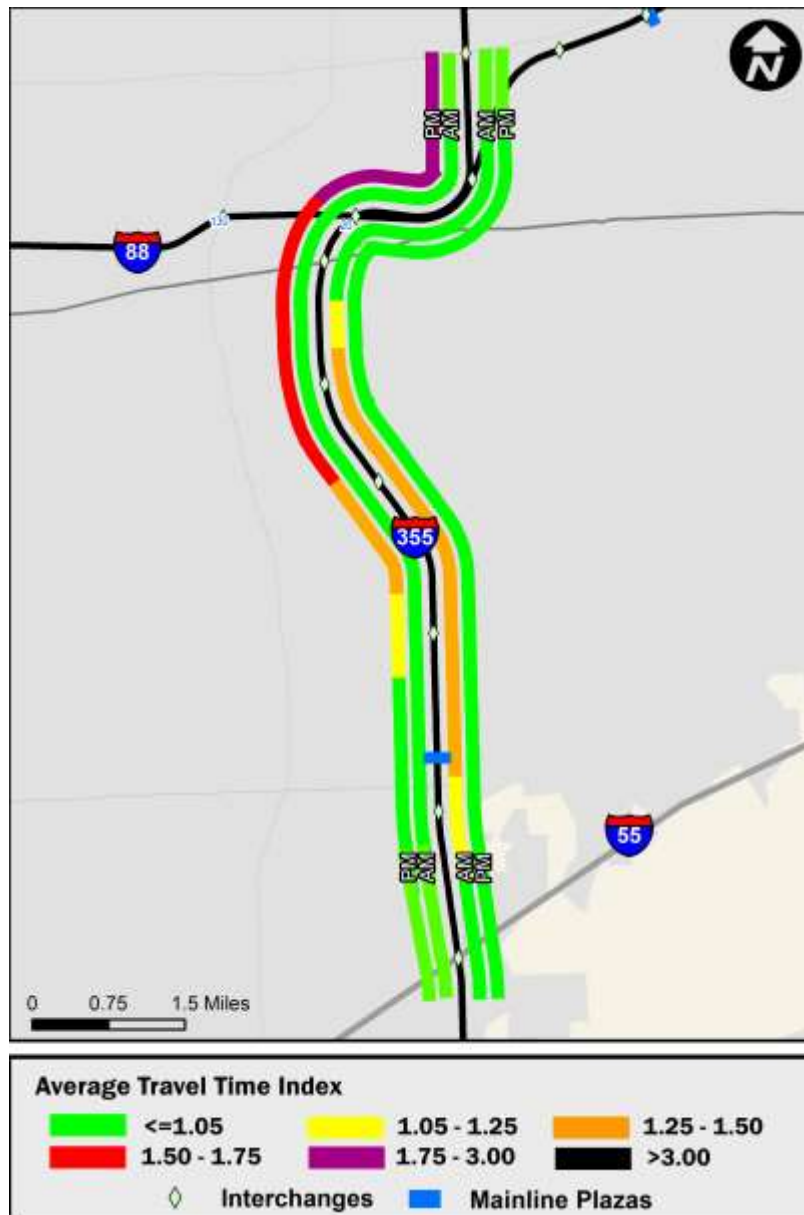

Quarter	Range	Average Speed (mph)		Average Travel Time Index		Planning Time Index		Total Delay (veh-hrs / 1000 VMT)		Average Daily Delay (veh-hrs)		Percent Congested Travel	
		AM	PM	AM	PM	AM	PM	AM	PM	AM	PM	AM	PM
1	January -March	57	54	1.04	1.10	1.30	1.29	1.8	2.6	517	779	21	35
2	April-June	55	48	1.08	1.25	1.28	1.43	2.5	5.0	752	1,598	25	40
3	July-September	55	46	1.09	1.31	1.28	1.50	2.6	6.0	760	1,867	25	43
4	October-December	54	48	1.11	1.25	1.31	1.51	2.9	5.0	794	1,491	24	40
Total	2016 Entire Year	55	49	1.08	1.23	1.29	1.43	2.5	4.7	706	1,434	24	39

Data source: INRIX. Roadway performance measures sections and terms are defined on pages 1-4 and 1-5.

FIGURE 5-AC: ROADWAY PERFORMANCE MEASURES—CENTRAL SECTION



Quarter	Range	Average Speed (mph)		Average Travel Time Index		Planning Time Index		Total Delay (veh-hrs / 1000 VMT)		Average Daily Delay (veh-hrs)		Percent Congested Travel	
		AM	PM	AM	PM	AM	PM	AM	PM	AM	PM	AM	PM
1	January -March	67	67	0.89	0.89	0.93	0.93	0.0	0.0	5	3	1	1
2	April-June	67	68	0.90	0.89	0.93	0.92	0.2	0.0	41	2	1	0
3	July-September	67	67	0.89	0.89	0.93	0.92	0.1	0.1	28	24	2	1
4	October-December	67	67	0.89	0.90	0.92	0.94	0.0	0.0	7	6	1	1
Total	2016 Entire Year	67	67	0.89	0.89	0.93	0.93	0.1	0.0	20	9	2	1

Data source: INRIX. Roadway performance measures sections and terms are defined on pages 1-4 and 1-5.

FIGURE 5-AD: ROADWAY PERFORMANCE MEASURES—SOUTHERN SECTION

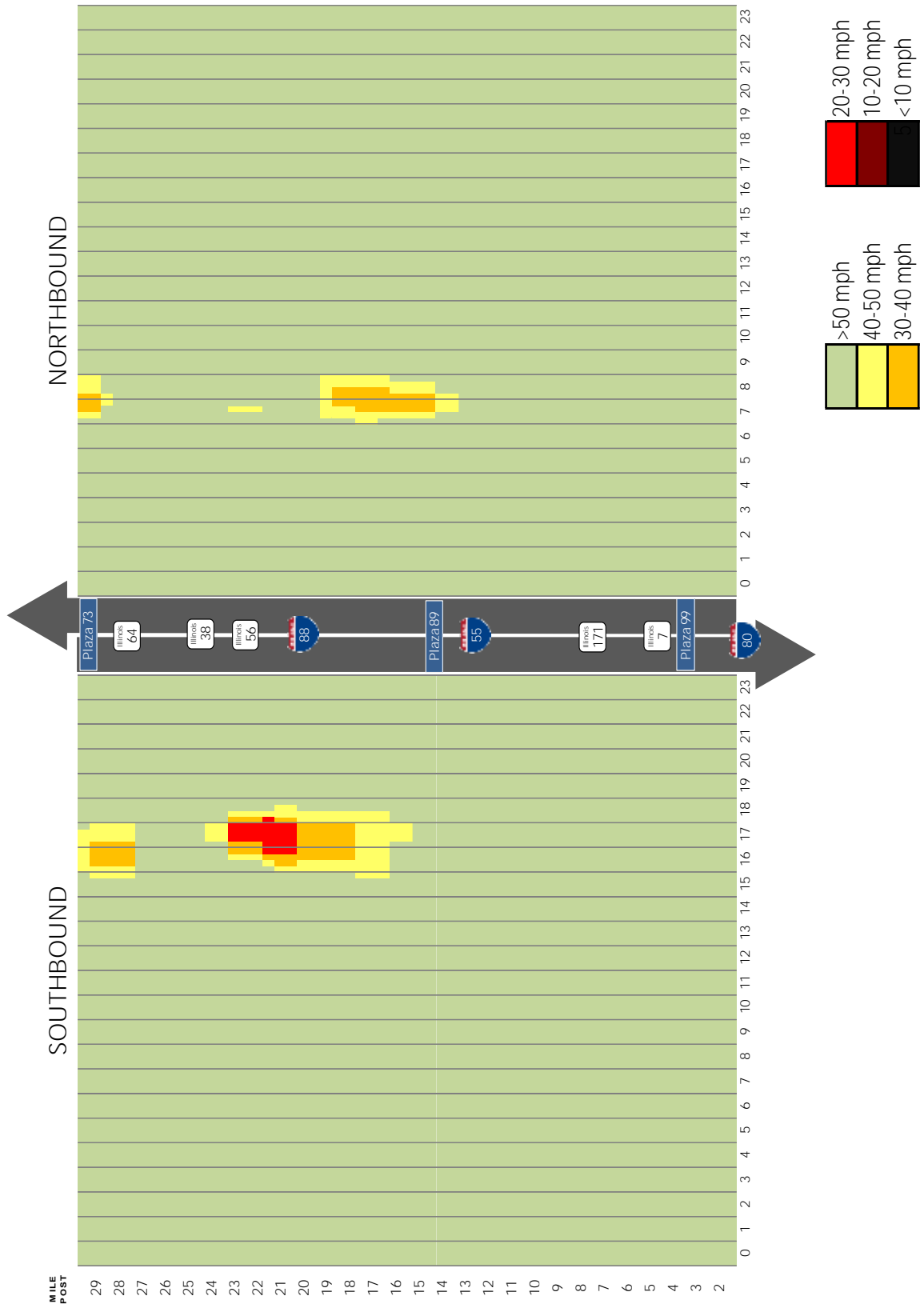

FIGURE 5-AE: AVERAGE SPEED CONTOURS, MP 1.5 TO 29.5



This Page Is Intentionally Left Blank



Section 5

Illinois Route 390 Tollway



SECTION 6

Illinois Route 390 Tollway

TABULATIONS TABLE

	PAGE
6-A Average Daily Traffic Volumes Between Interchanges 2016 (Westbound)	6-2
6-B Average Daily Traffic Volumes Between Interchanges 2016 (Eastbound)	6-2
6-C General Statistics for Mainline Plazas	6-3
6-D Indexed Monthly Variations by Mainline Plaza	6-4
6-E Indexed Daily Variation by Mainline Plaza	6-4
6-F Annual Total Transactions by Toll Plaza	6-5
6-G Average Daily Traffic Data	6-5

ILLUSTRATIONS FIGURE

	PAGE
6-A Mainline Plaza Highest Hourly Volume Plaza 326 EB	6-6
6-B Mainline Plaza Highest Hourly Volume Plaza 326 WB	6-6
6-C Mainline Plaza Highest Hourly Volume Plaza 328 EB	6-6
6-D Mainline Plaza Highest Hourly Volume Plaza 328 WB	6-6
6-E Mainline Plaza Highest Hourly Volume Plaza 330 EB	6-7
6-F Mainline Plaza Highest Hourly Volume Plaza 330 WB	6-7
6-G Average Daily Traffic Trends Plaza 326 Plum Grove Road	6-8
6-H Average Daily Traffic Trends Plaza 328 Mitchell Boulevard	6-8
6-I Average Daily Traffic Trends Plaza 330 Lake Street	6-8
6-J Average Weekday Speed Distributions, Western Section—Eastbound	6-9
6-K Average Weekday Speed Distributions, Western Section—Westbound	6-9
6-L Roadway Performance Measures, Western Section	6-10
6-M Average Speed Contours, MP 5.9 to 12.5	6-11

TABLE 6-A: AVERAGE DAILY TRAFFIC VOLUMES* BETWEEN INTERCHANGES 2016 (WESTBOUND)

Location	Mile Post	Miles Btwn. Int.	ADT 2016
Arlington Heights Road	13.5		
Rohlwing Road (IL 53)	12.1	1.4	14,330
Meacham Road exit	11.7	0.4	31,140
Meacham Road	11.2	0.5	24,080
Toll Plaza 326		1.5	28,210
Roselle Road exit	9.7		
Roselle Road entrance	9.1	0.6	24,330
Toll Plaza 328		0.8	27,110
Wright Boulevard	8.3		
Irving Park Road (IL 19)	7.6	0.7	24,520
Springinsouth Rd	7.4	0.2	18,170
Gary Avenue	7.1	0.3	13,170
Toll Plaza 330		1.1	14,070
Lake Street (US 20)	6.0		

TABLE 6-B: AVERAGE DAILY TRAFFIC VOLUMES* BETWEEN INTERCHANGES 2016 (EASTBOUND)

Location	Mile Post	Miles Btwn. Int.	ADT 2016
Arlington Heights Road	13.5		
Eisenhower Expressway (I-290)	11.7	1.8	6,930
Meacham Road	11.2	0.5	26,420
Toll Plaza 326		1.5	29,590
Roselle Road entrance	9.7		
Roselle Road exit	9.1	0.6	25,520
Toll Plaza 328		0.8	27,940
Wright Boulevard	8.3		
Irving Park Road (IL 19)	7.6	0.7	25,400
Springinsouth Rd	7.4	0.2	19,170
Gary Avenue	7.1	0.3	14,400
Toll Plaza 330		0.9	15,290
Lake Street (US 20) entrance	6.2		
Lake Street (US 20)	6.0	0.2	10,570

*Toll collection on Illinois Route 390 began July 5, 2016. Average daily traffic volumes are for July 5 through December 31, 2016.



**TABLE 6-C: GENERAL STATISTICS FOR MAINLINE PLAZAS
(Vehicles/Hour)**

Mainline Plaza	Dir.	30th HV	Period	Mean	Med.	Max.	Min.	Std. Dev.	85th %
326 Plum Grove Road	EB	3,905	AM Peak	3,342	3,241	4,162	2,618	433	3,904
			PM Peak	1,653	1,653	1,984	1,354	110	1,755
			OFF Peak	1,111	1,141	3,771	70	807	1,806
			Weekend	1,114	1,124	3,885	111	716	1,745
			Holidays	993	1,010	3,151	94	661	1,611
	WB	3,968	AM Peak	1,097	1,063	1,365	677	148	1,265
			PM Peak	3,620	3,617	4,295	2,961	303	3,951
			OFF Peak	1,065	1,134	3,037	78	738	1,799
			Weekend	1,059	1,051	3,999	125	713	1,645
			Holidays	939	908	3,361	68	686	1,495
328 Mitchell Boulevard	EB	3,734	AM Peak	3,184	3,060	4,009	2,425	442	3,730
			PM Peak	1,612	1,610	1,906	1,393	100	1,708
			OFF Peak	1,043	1,088	3,567	67	762	1,694
			Weekend	1,048	1,053	3,716	99	678	1,647
			Holidays	934	934	2,967	84	624	1,473
	WB	3,902	AM Peak	1,065	996	1,387	592	183	1,281
			PM Peak	3,570	3,577	4,189	2,889	302	3,897
			OFF Peak	1,018	1,071	3,209	75	713	1,710
			Weekend	1,013	1,003	3,933	119	694	1,558
			Holidays	904	880	3,346	61	654	1,368
330 Lake Street	EB	2,122	AM Peak	1,847	1,791	2,302	1,191	232	2,116
			PM Peak	788	788	969	650	65	851
			OFF Peak	568	547	2,141	33	432	942
			Weekend	575	575	2,119	59	378	893
			Holidays	507	510	1,685	44	345	791
	WB	2,170	AM Peak	488	488	637	267	66	554
			PM Peak	1,972	1,988	2,411	1,524	185	2,145
			OFF Peak	521	523	1,580	34	378	880
			Weekend	527	518	2,232	53	375	813
			Holidays	470	464	1,841	34	350	740

AM Peak = Weekday 6:00 AM To 8:00 AM Except Fridays
 PM Peak = Weekday 4:00 PM To 6:00 PM Except Fridays
 OFF Peak = Weekdays Except Fridays and AM and PM Peak Periods
 Weekend = Fridays, Saturdays, and Sundays
 Holidays = See Page 1-6 for a list of Holidays.



TABLE 6-D: INDEXED MONTHLY VARIATION BY MAINLINE PLAZA

Month	Plum Grove Road	Mitchell Boulevard	Lake Street
January			
February			
March			
April			
May			
June			
July	1.02	1.01	1.03
August	1.03	1.03	1.04
September	1.01	1.02	1.02
October	1.02	1.02	1.02
November	0.99	0.99	0.98
December	0.93	0.93	0.91

Monthly variation on IL 390 is not comparable to other routes due to a partial year of operations.

TABLE 6-E: INDEXED DAILY VARIATION BY MAINLINE PLAZA

Month	Day	Plum Grove Road	Mitchell Boulevard	Lake Street
August	Monday	1.04	1.04	1.06
	Tuesday	1.01	1.01	1.02
	Wednesday	1.02	1.02	1.02
	Thursday	1.02	1.03	1.03
	Friday	1.02	1.03	1.04
	Saturday	1.02	1.03	1.03
	Sunday	1.06	1.06	1.07
December	Monday	0.90	0.89	0.87
	Tuesday	0.95	0.96	0.93
	Wednesday	0.97	0.96	0.94
	Thursday	0.97	0.96	0.94
	Friday	0.93	0.93	0.91
	Saturday	0.91	0.91	0.89
	Sunday	0.87	0.87	0.85

Table 6-E includes Monthly Variation



TABLE 6-F: ANNUAL TOTAL TRANSACTIONS BY TOLL PLAZA

Plaza	Plaza Code*	2015	2016	Percentage Change
326 Plum Grove Road	ME		10,405,766	
328 Mitchell Boulevard	ME		9,910,149	
330 Lake Street	ME		5,285,292	
IL Route 390 Total			25,601,207	

* M=Mainline / R=Ramp / A=Attended Ramp Plaza / E=Electronic Toll Collection Only Ramp
 1=Toll Collected in One Direction Only

TABLE 6-G: AVERAGE DAILY TRAFFIC DATA

Year	Average Daily Total			Average Trip
	Vehicles	Vehicle Miles	Transactions	Length (Miles)
2016	72,360	312,926	142,229	4.32



FIGURE 6-A

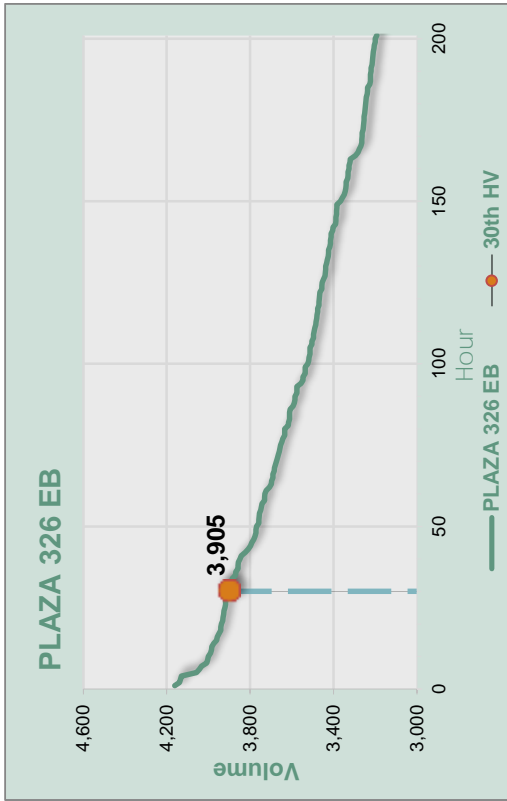

FIGURE 6-B

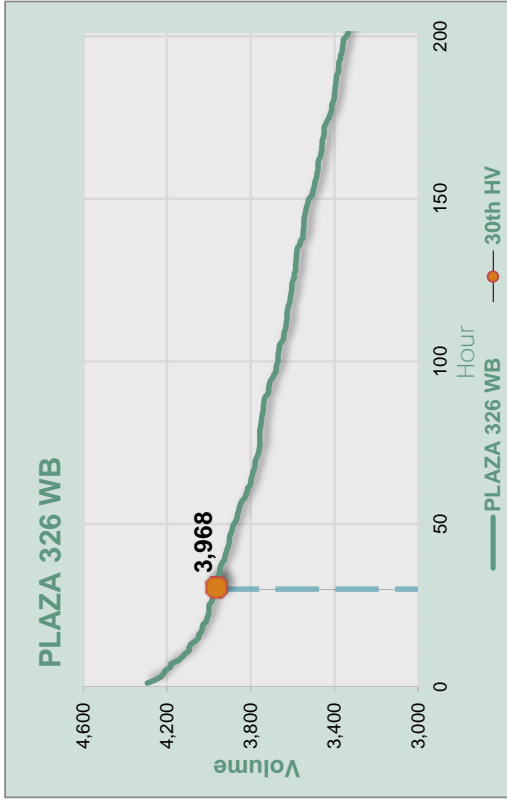

FIGURE 6-C

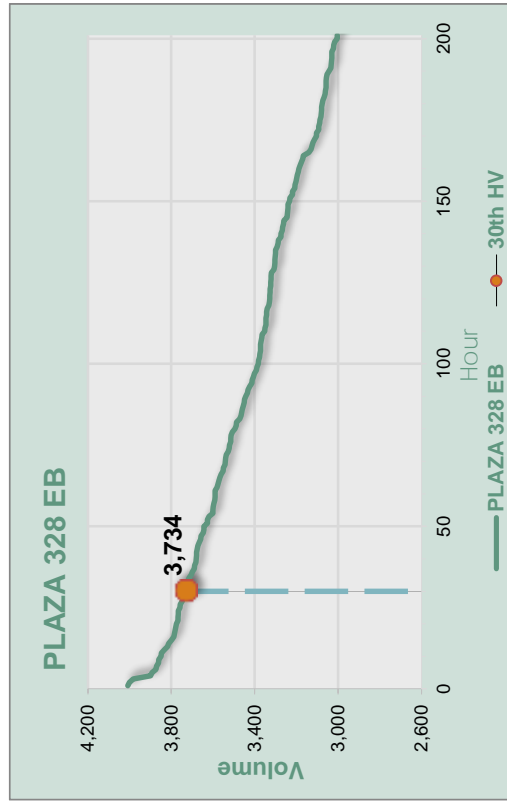
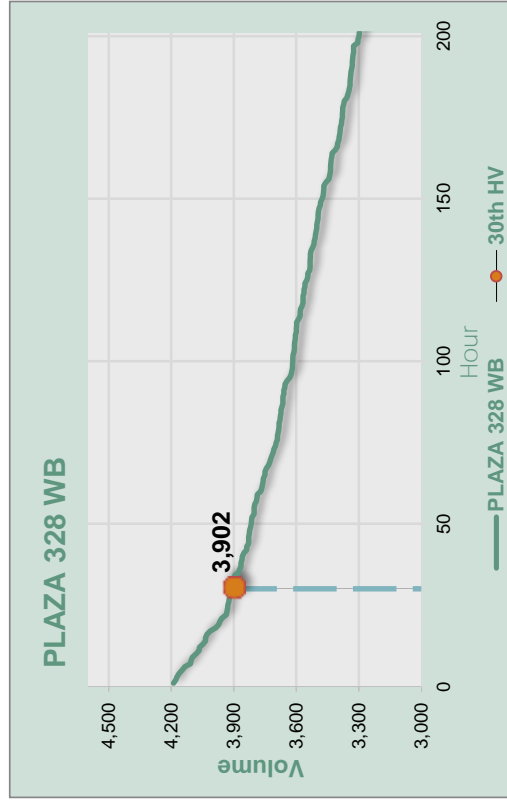

FIGURE 6-D



MAINLINE PLAZA HIGHEST HOURLY VOLUME



FIGURE 6-F

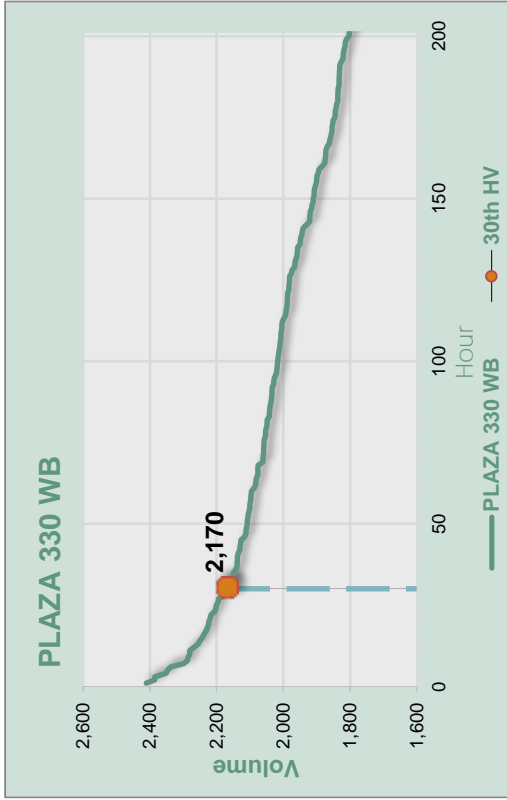
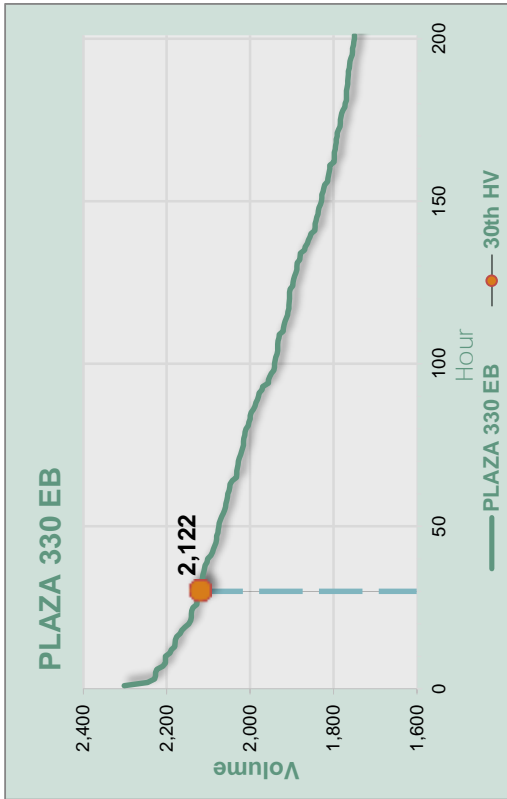

FIGURE 6-E



MAINLINE PLAZA HIGHEST HOURLY VOLUME



FIGURE 6-G

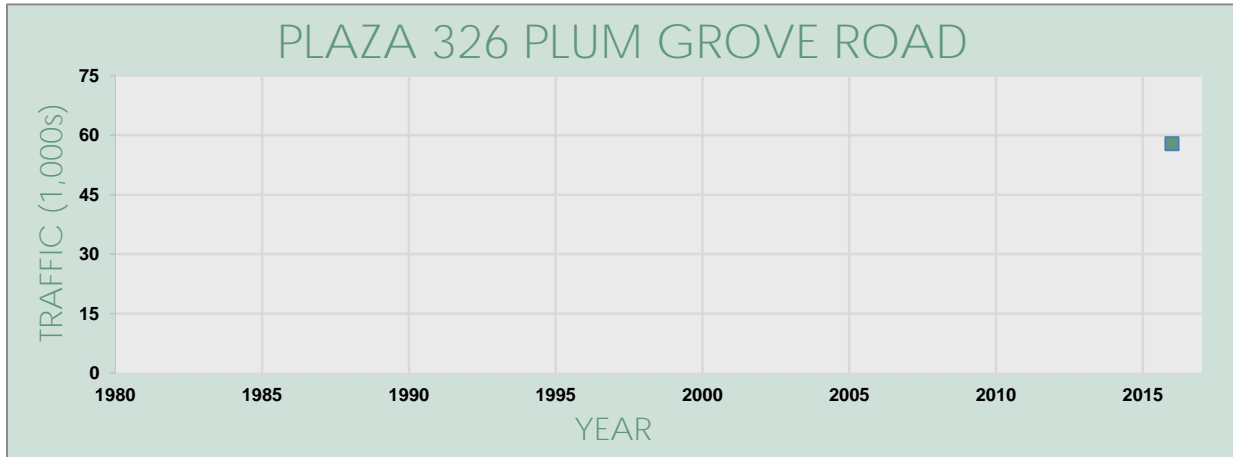

FIGURE 6-H

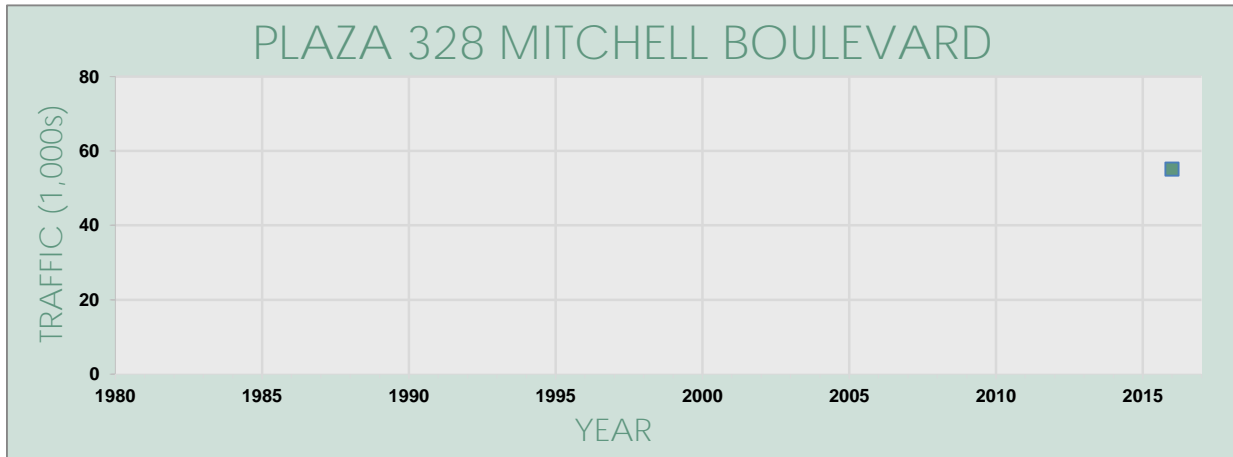
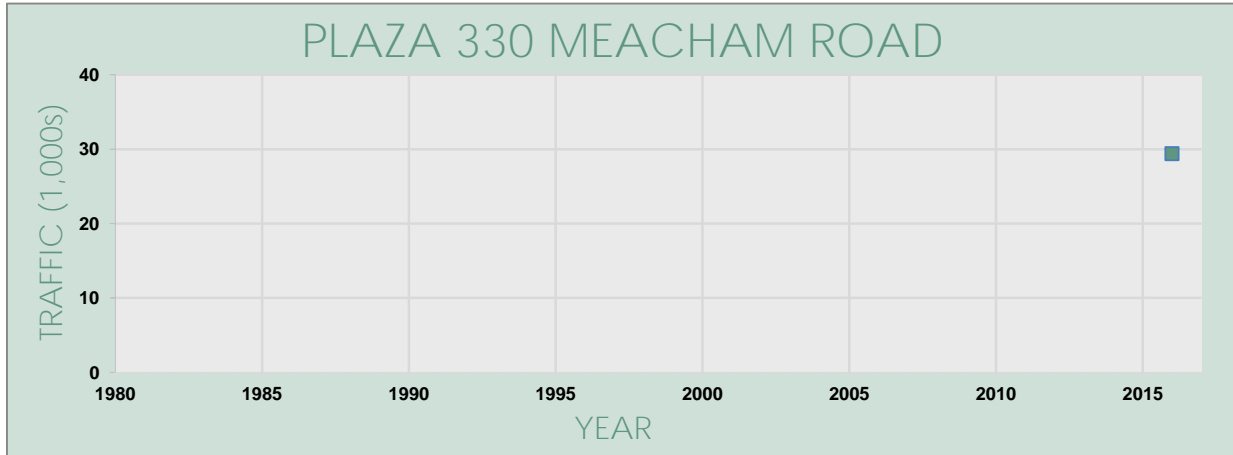

FIGURE 6-I



AVERAGE DAILY TRAFFIC TRENDS



AVERAGE WEEKDAY SPEED DISTRIBUTIONS, WESTERN SECTION

FIGURE 6-J

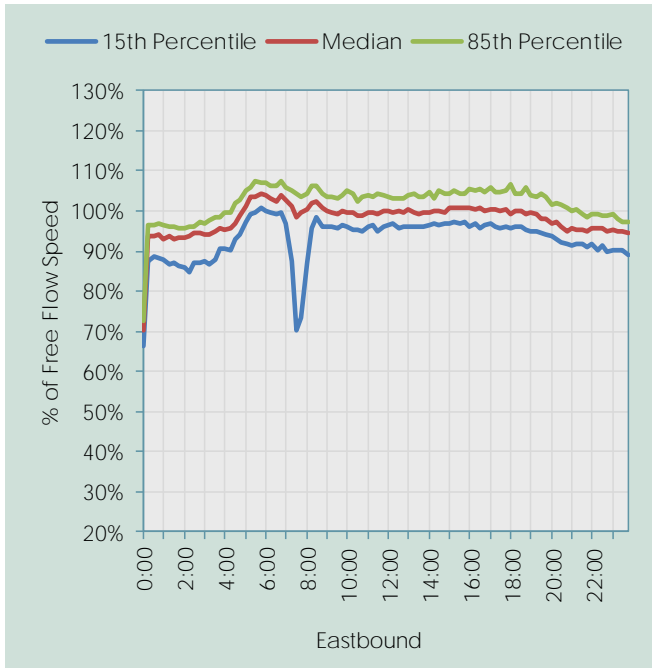
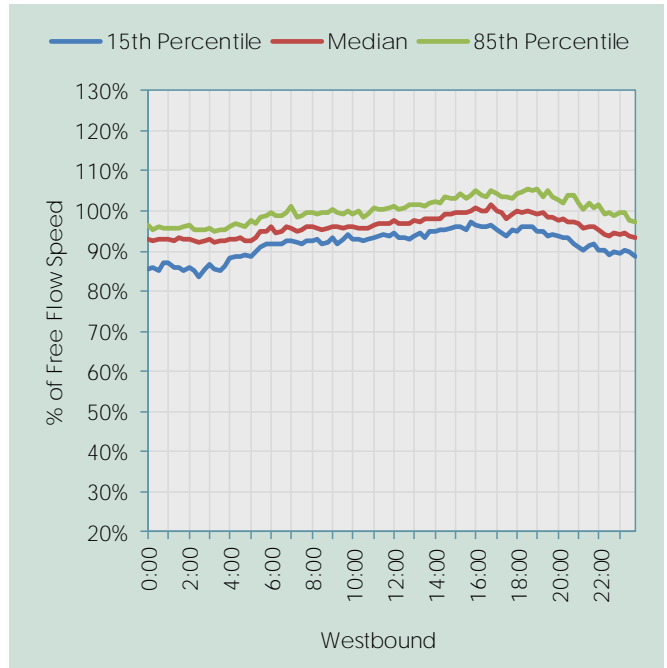
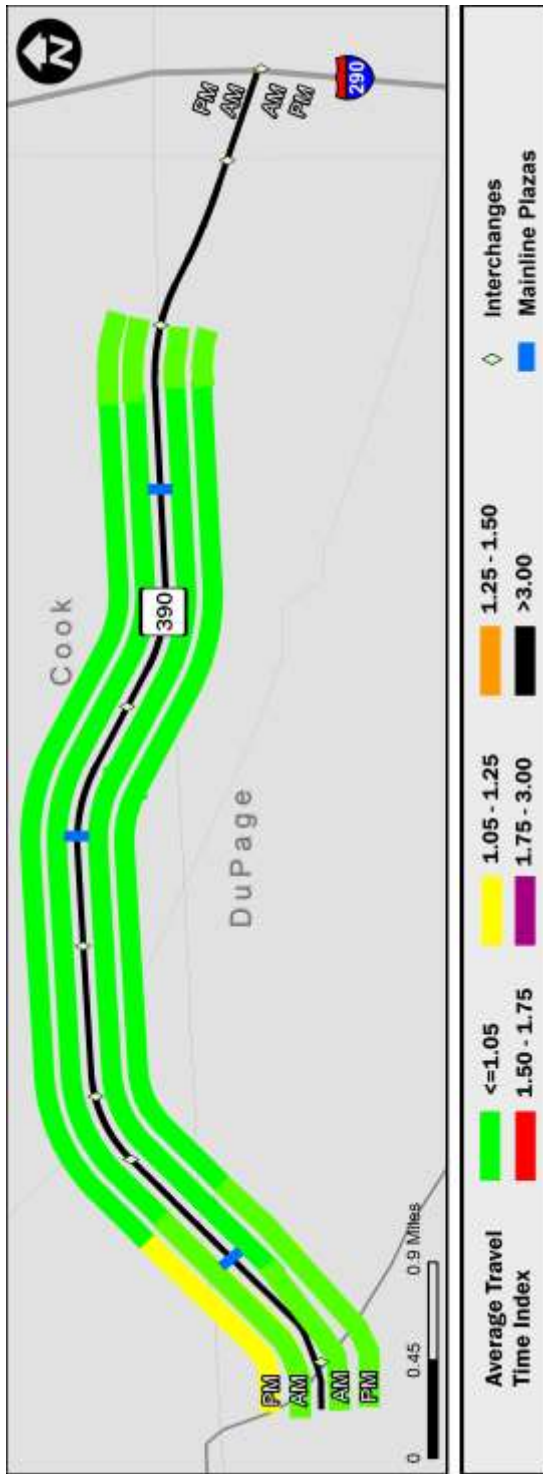

FIGURE 6-K





Quarter	Range	Average Speed (mph)		Average Travel Time Index		Planning Time Index		Total Delay (veh-hrs / 1000 VMT)		Average Daily Delay (veh-hrs)		Percent Congested Travel	
		AM	PM	AM	PM	AM	PM	AM	PM	AM	PM	AM	PM
1	January -March	N/A	N/A	N/A	N/A	N/A	N/A	N/A	N/A	N/A	N/A	N/A	N/A
2	April-June	N/A	N/A	N/A	N/A	N/A	N/A	N/A	N/A	N/A	N/A	N/A	N/A
3	July-September	59	61	1.02	0.98	1.15	1.02	0.9	0.3	57	22	42	24
4	October-December	59	60	1.01	1.00	1.08	1.03	0.8	0.4	47	29	39	35
Total	2016 Entire Year	59	61	1.02	0.99	1.11	1.03	0.8	0.4	52	26	41	29

IL 390 opened for revenue operations on July 5, 2016. Data source: INRIX. Roadway performance measures sections and terms are defined on pages 1-4 and 1-5.

FIGURE 6-L: ROADWAY PERFORMANCE MEASURES—WESTERN SECTION

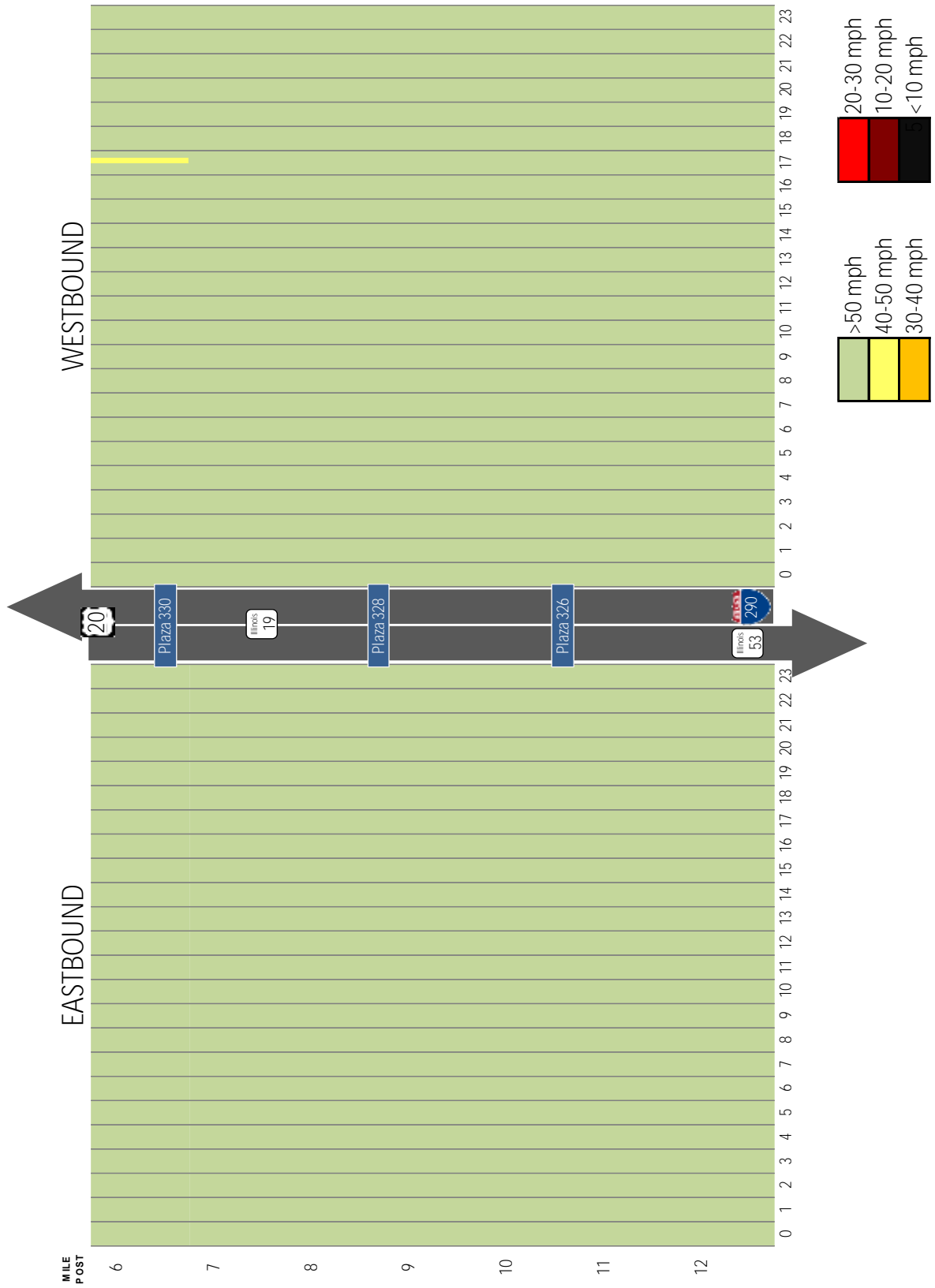

FIGURE 6-M: AVERAGE SPEED CONTOURS, MP 5.9 TO 12.5



SECTION 6

APPENDICES

PAGE NUMBERS FOR TOLLWAY SCHEMATICS, APPENDICES A TO C

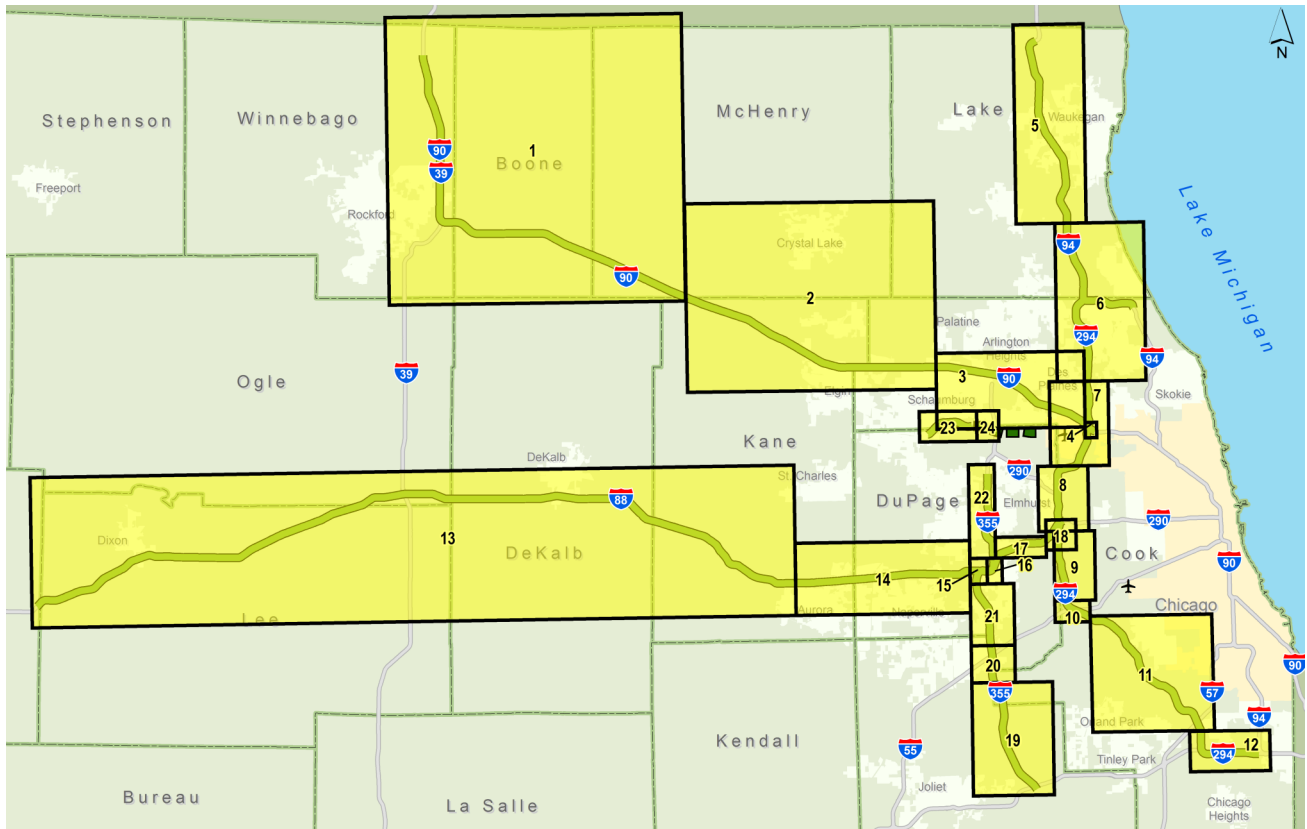

Jane Addams Memorial Tollway

- 1 – From Rockton Road to Marengo (Plaza 7)
- 2 – From U.S. Route 20, Marengo to Barrington Road
- 3 – From Roselle Road to Devon Avenue
- 4 – From Tri-State Tollway to Kennedy Expressway

Tri-State Tollway

- 5 – From Russell Road to Lake Forest Oasis
- 6 – From Town Line Road (Illinois 60) to Golf Road (Illinois 58) and Edens Spur
- 7 – From Dempster Street to O'Hare Oasis
- 8 – From North Avenue / Lake Street to Reagan Memorial Tollway (I-88)
- 9 – From Roosevelt Road to Hinsdale Oasis
- 10 – From Joliet Road (Plaza 37) to Willow Springs Road (Plaza 34)
- 11 – From Archer / La Grange / 79th Street to I-57
- 12 – From 159th Street (Plaza 40) to Bishop Ford / Kingery Expressway

Reagan Memorial Tollway

- 13 – From Illinois Route 26 to Orchard Road
- 14 – From Illinois Route 31 to Illinois Route 53
- 15 – Veterans Memorial Tollway West Interchange
- 16 – Veterans Memorial Tollway East Interchange
- 17 – From Highland Avenue to Harger Road
- 18 – From Roosevelt Road to Eisenhower Expressway (I-290)

Veterans Memorial Tollway

- 19 – From Interstate 80 to 127th Street
- 20 – At Interstate 55
- 21 – From Boughton Road To Maple Avenue
- 22 – From Ogden Avenue / West Interchange to Army Trail Road

Illinois Route 390 Tollway

- 23 – From Lake Street to Plum Grove Road (Plaza 326)
- 24 – From Plum Grove Road (Plaza 326) to Interstate 290



APPENDIX A

2016 SYSTEMWIDE ANNUAL AVERAGE DAILY TRAFFIC SCHEMATICS



2016 Annual Average Daily Traffic

On Jane Addams Memorial Tollway, from Rockton Road to Marengo (Plaza 7)

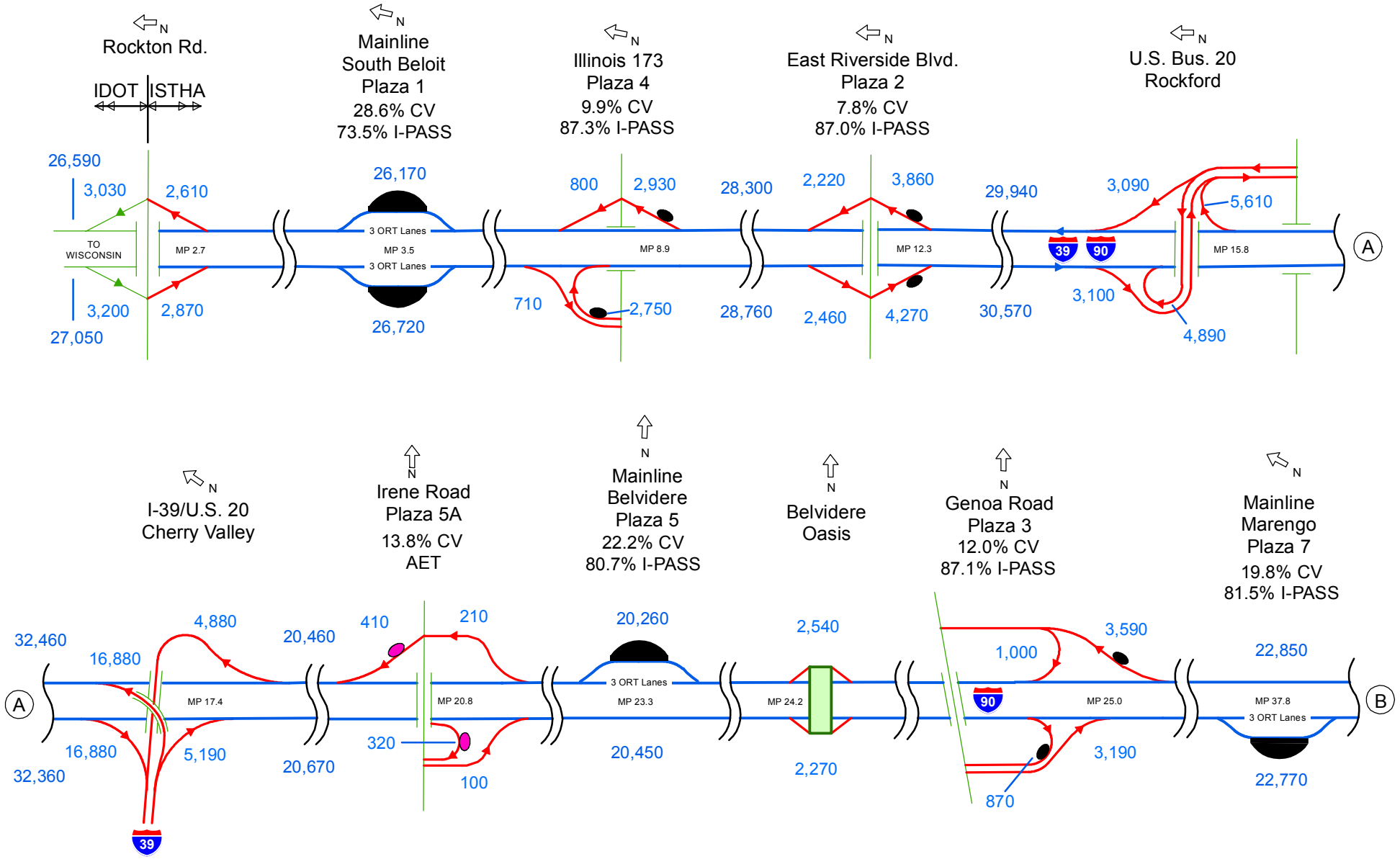

CV = Commercial Vehicles
 I-PASS = I-PASS Electronic Toll Collection
 ORT = Open Road Tolling Lanes
 AET = All Electronic Tolling





2016 Annual Average Daily Traffic

On Jane Addams Memorial Tollway, from U.S. 20, Marengo to Barrington Road

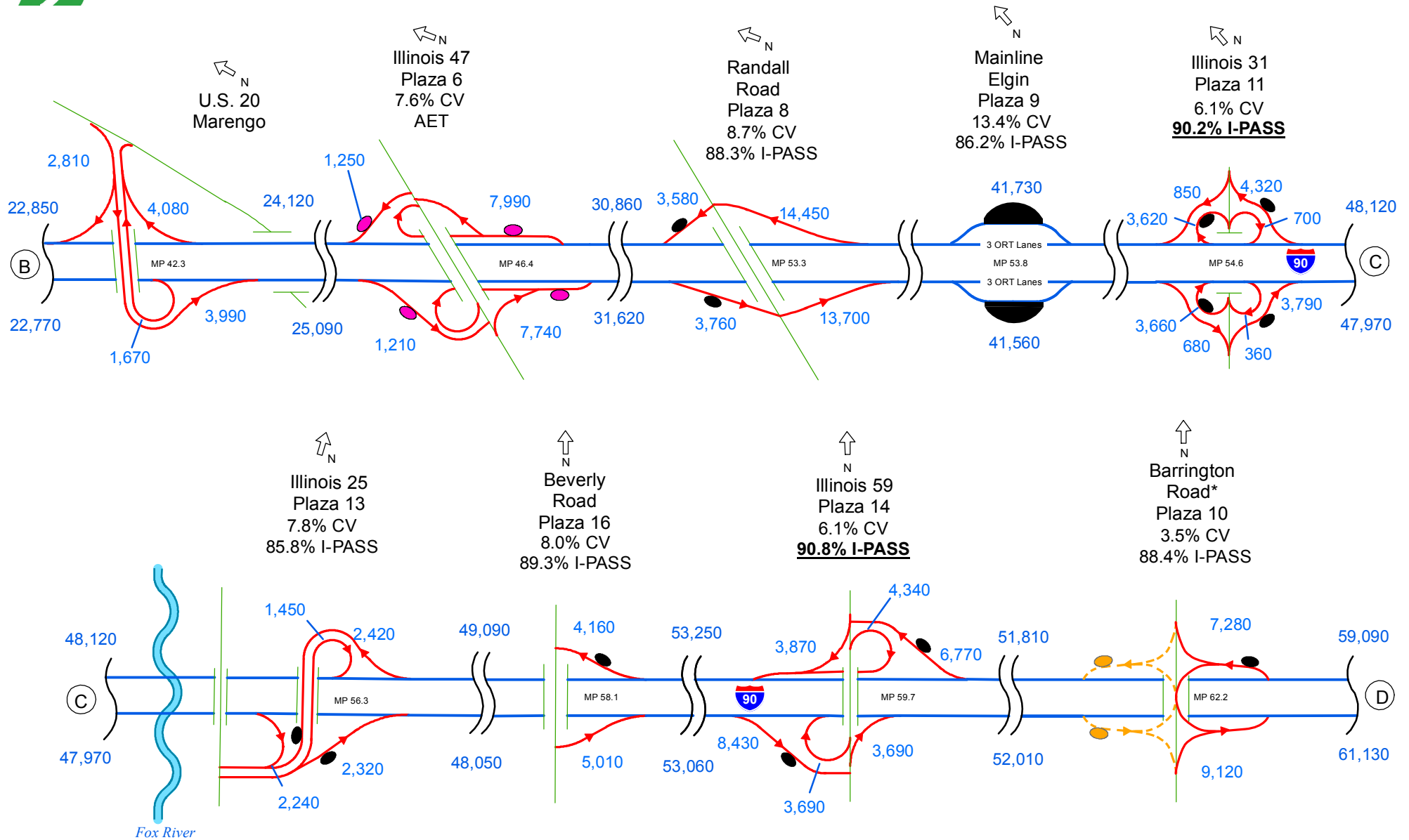

*New ramps at Barrington Road were under construction in 2016.

CV = Commercial Vehicles
 I-PASS = I-PASS Electronic Toll Collection
 ORT = Open Road Tolling Lanes
 AET = All Electronic Tolling





2016 Annual Average Daily Traffic

On Jane Addams Memorial Tollway, from Roselle Road to Devon Avenue

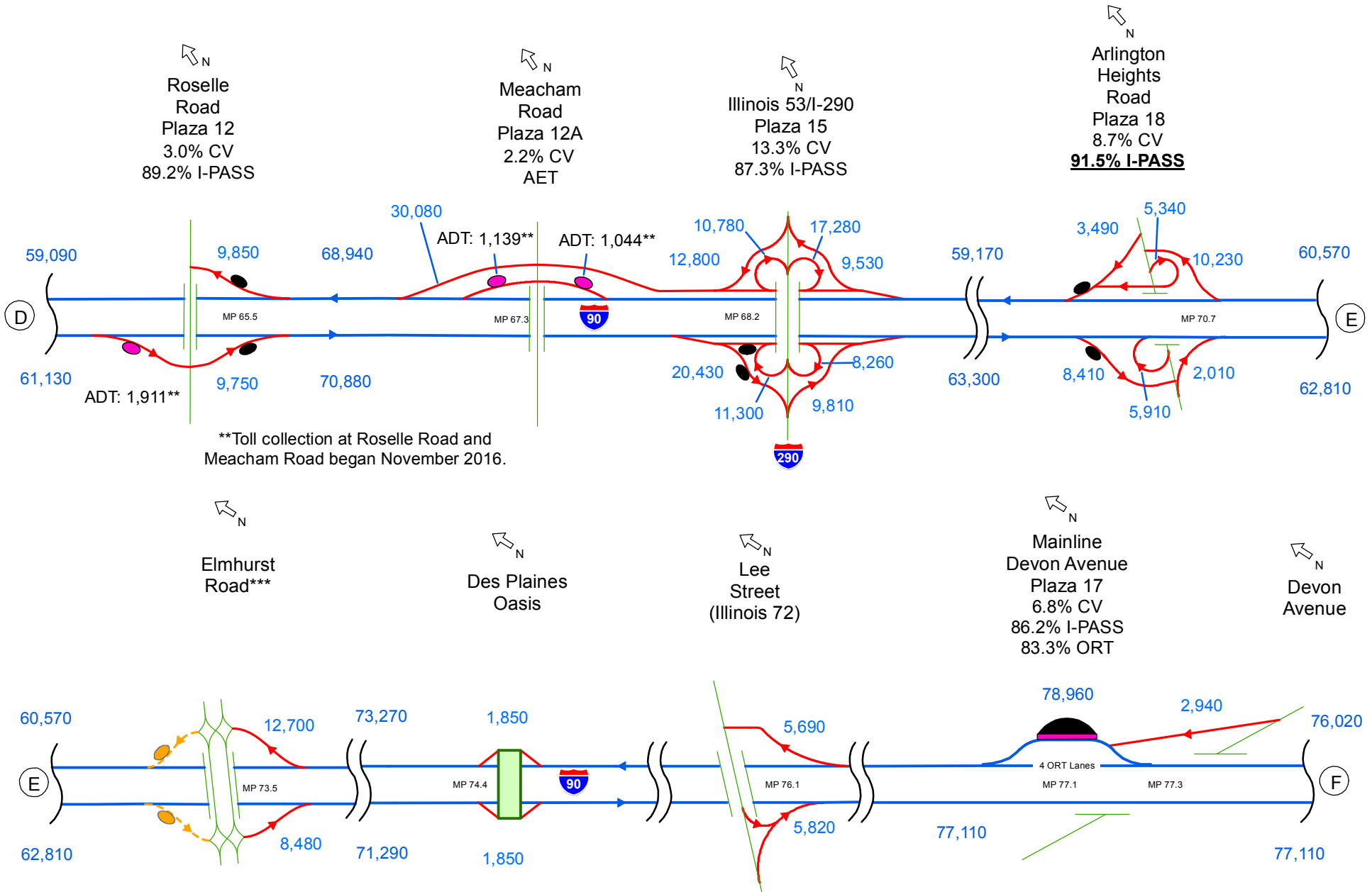

**Toll collection at Roselle Road and Meacham Road began November 2016.

CV = Commercial Vehicles
 I-PASS = I-PASS Electronic Toll Collection
 ORT = Open Road Tolling Lanes
 AET = All Electronic Tolling





2016 Annual Average Daily Traffic

On Jane Addams Memorial Tollway, from Tri-State Tollway to Kennedy Expressway

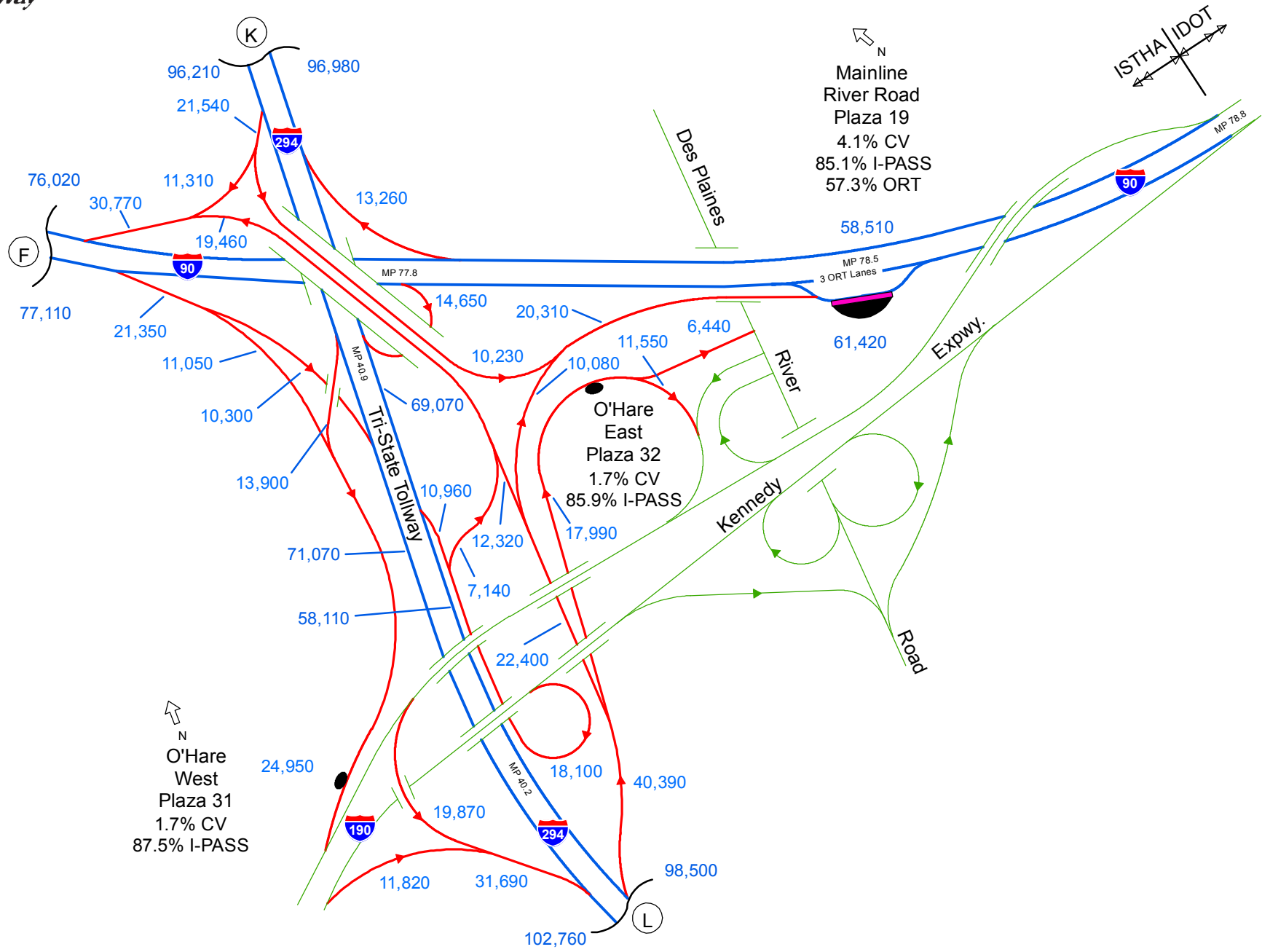

CV = Commercial Vehicles
 I-PASS = I-PASS Electronic Toll Collection
 ORT = Open Road Tolling Lanes
 AET = All Electronic Tolling





2016 Annual Average Daily Traffic

On Tri-State Tollway, from Russell Road to Lake Forest Oasis

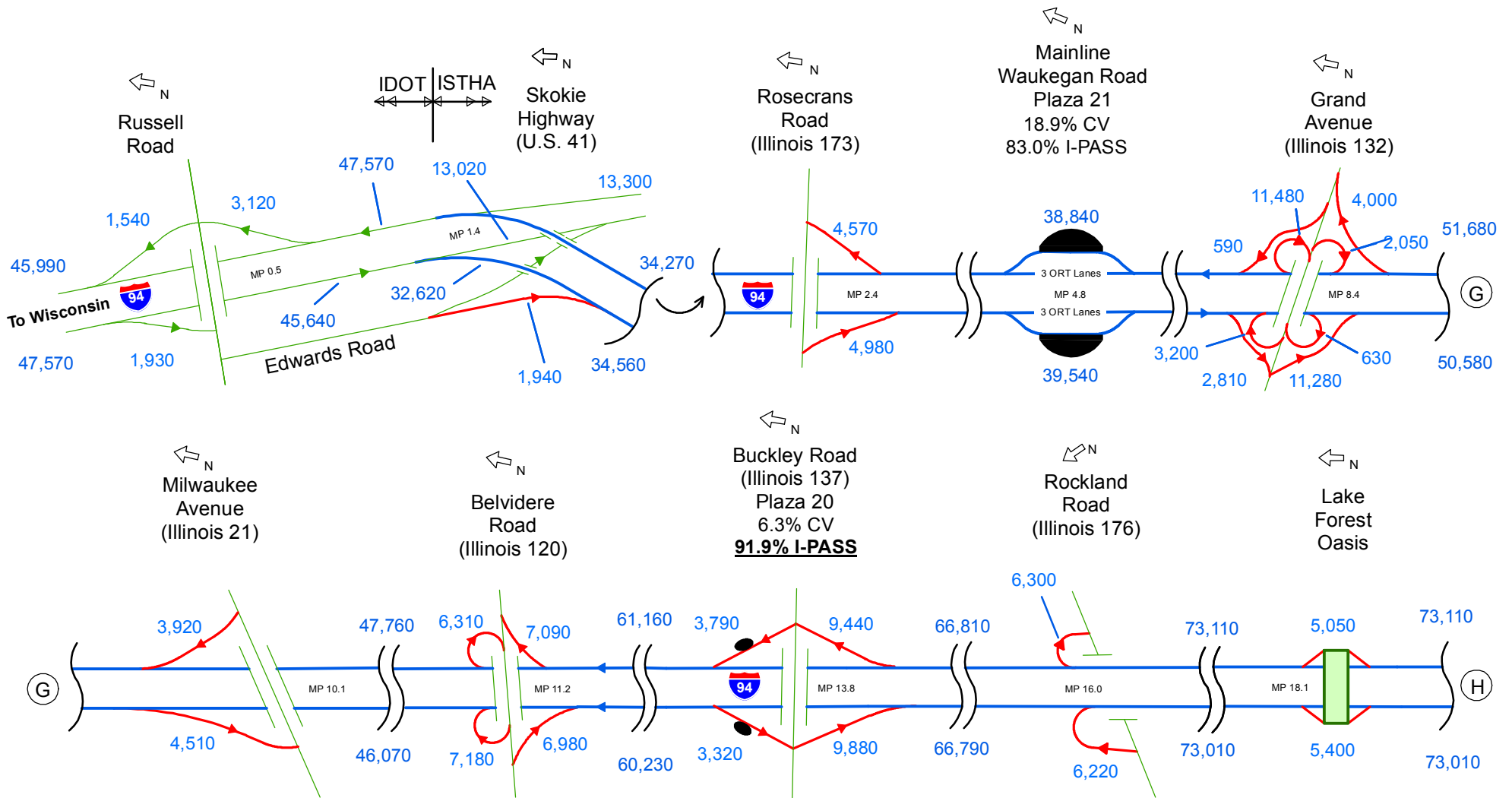

CV = Commercial Vehicles
 I-PASS = I-PASS Electronic Toll Collection
 ORT = Open Road Tolling Lanes
 AET = All Electronic Tolling





2016 Annual Average Daily Traffic

On Tri-State Tollway, from Town Line Road (Illinois 60) to Golf Road (Illinois 58) and Edens Spur

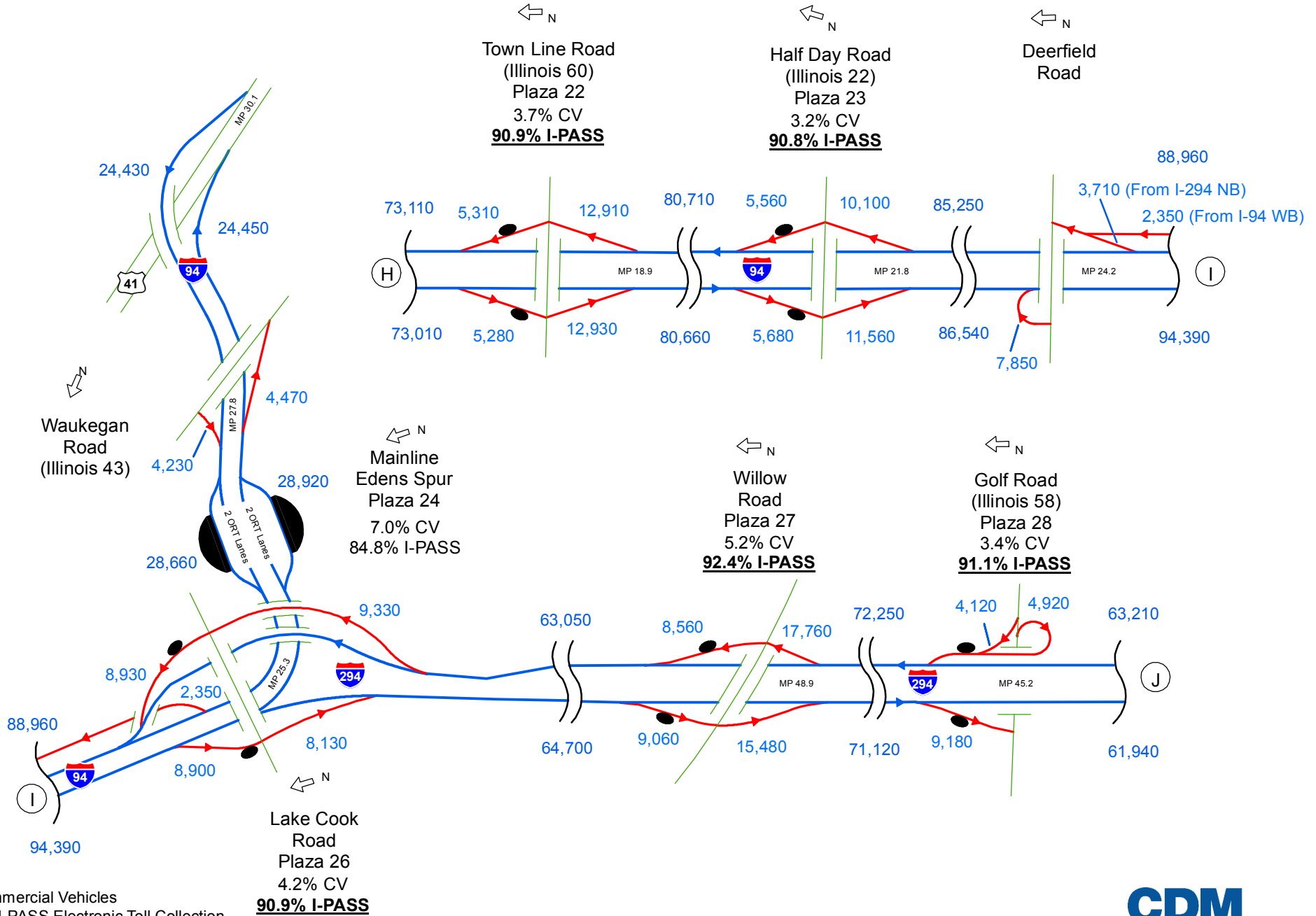

CV = Commercial Vehicles
I-PASS = I-PASS Electronic Toll Collection
ORT = Open Road Tolling Lanes
AET = All Electronic Tolling





2016 Annual Average Daily Traffic

On Tri-State Tollway, from Dempster Street to O'Hare Oasis

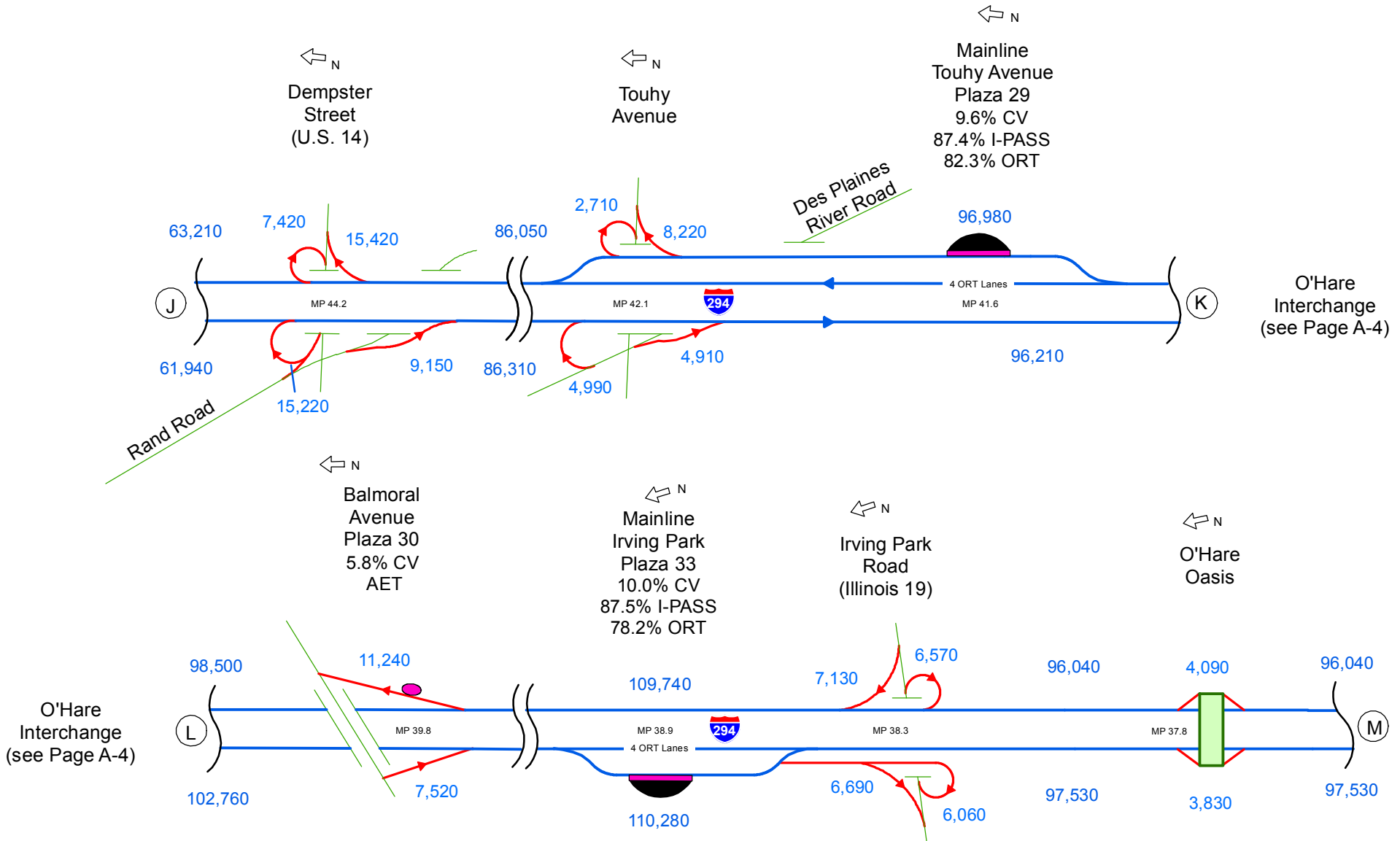

CV = Commercial Vehicles
 I-PASS = I-PASS Electronic Toll Collection
 ORT = Open Road Tolling Lanes
 AET = All Electronic Tolling





2016 Annual Average Daily Traffic

On Tri-State Tollway, from North Avenue / Lake Street to Reagan Memorial Tollway (I-88)

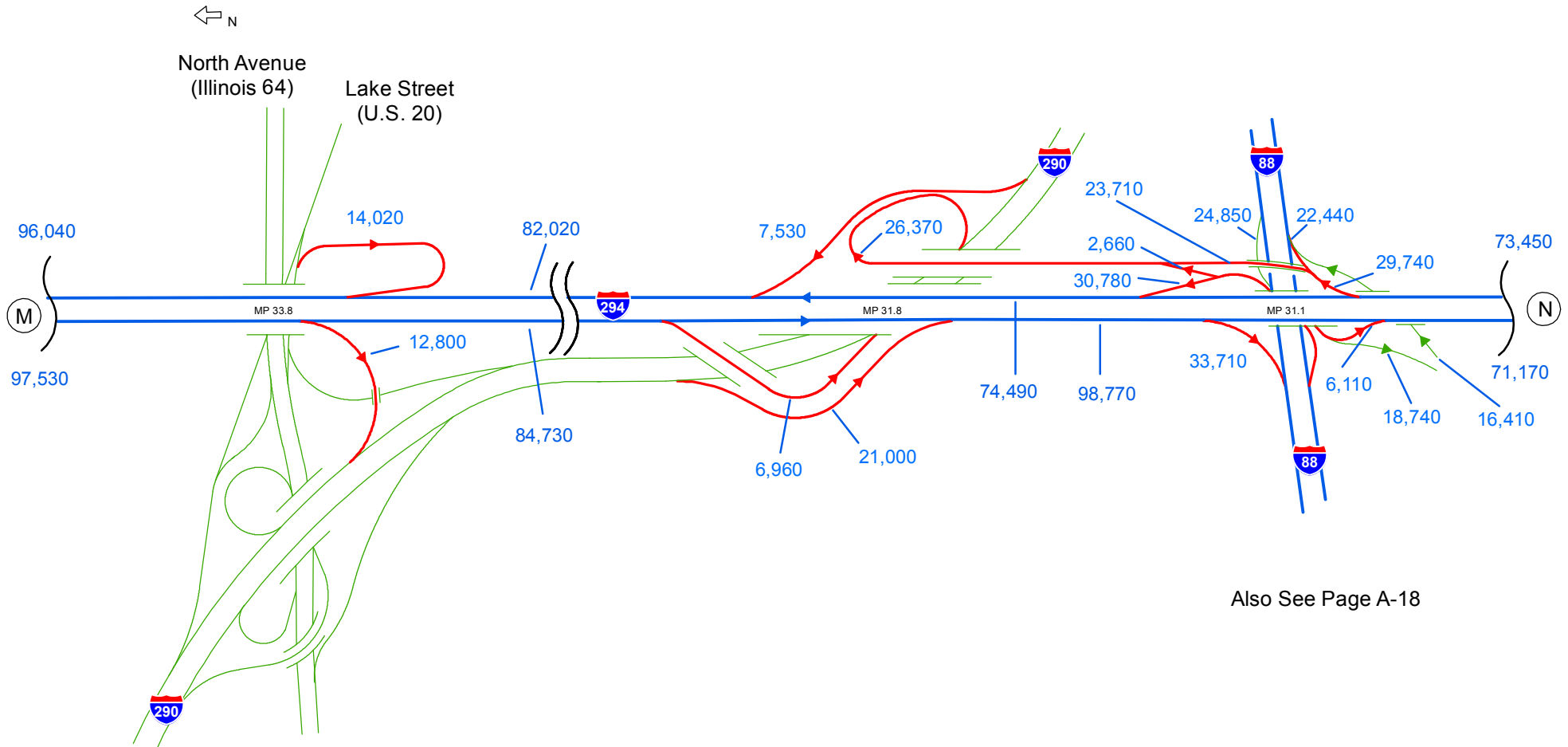

Also See Page A-18

CV = Commercial Vehicles
 I-PASS = I-PASS Electronic Toll Collection
 ORT = Open Road Tolling Lanes
 AET = All Electronic Tolling





2016 Annual Average Daily Traffic

On Tri-State Tollway, from Roosevelt Road to Hinsdale Oasis

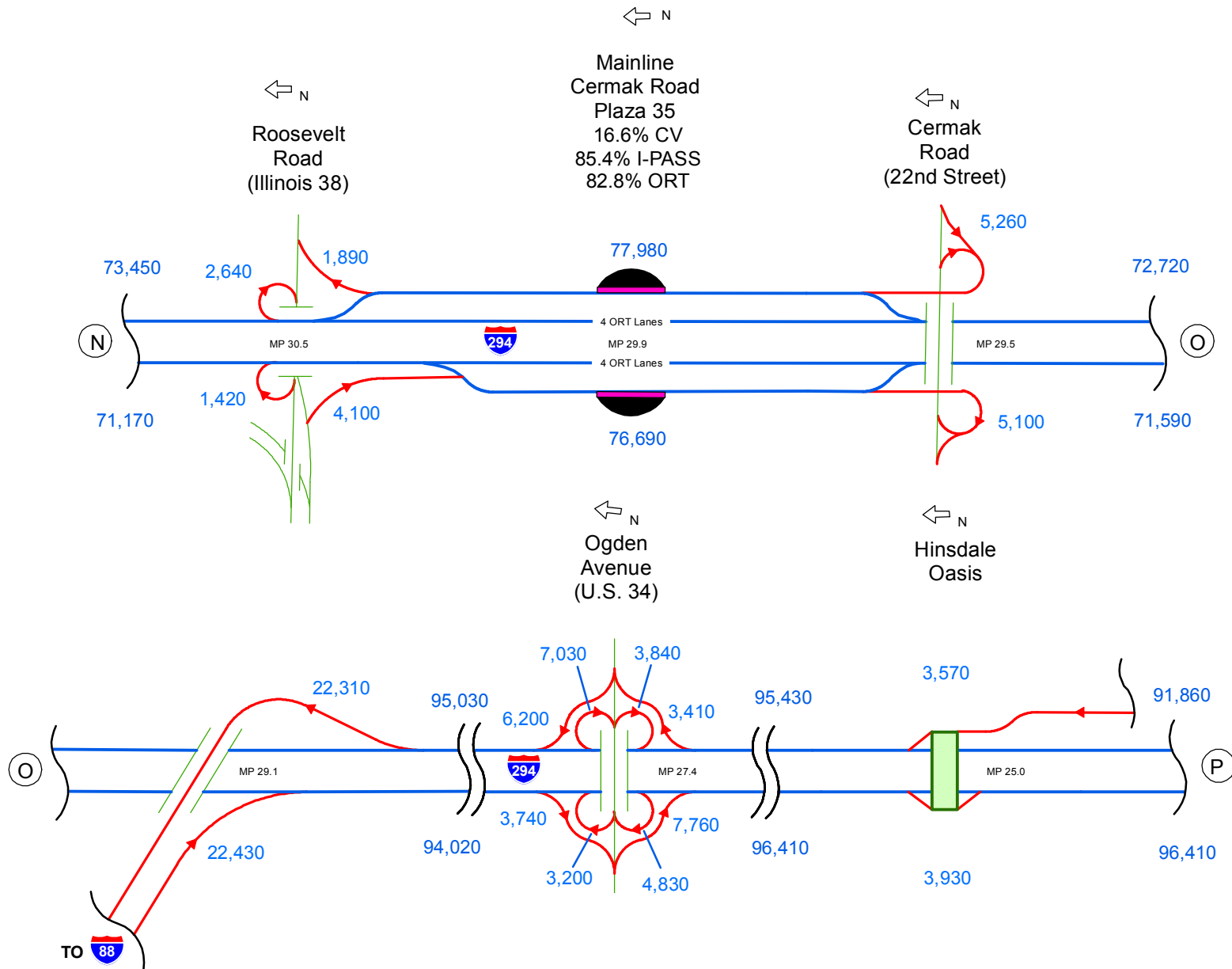

Also See Page A-17

CV = Commercial Vehicles
 I-PASS = I-PASS Electronic Toll Collection
 ORT = Open Road Tolling Lanes
 AET = All Electronic Tolling





2016 Annual Average Daily Traffic

On Tri-State Tollway, from Joliet Road (Plaza 37) to Willow Springs Road (Plaza 34)

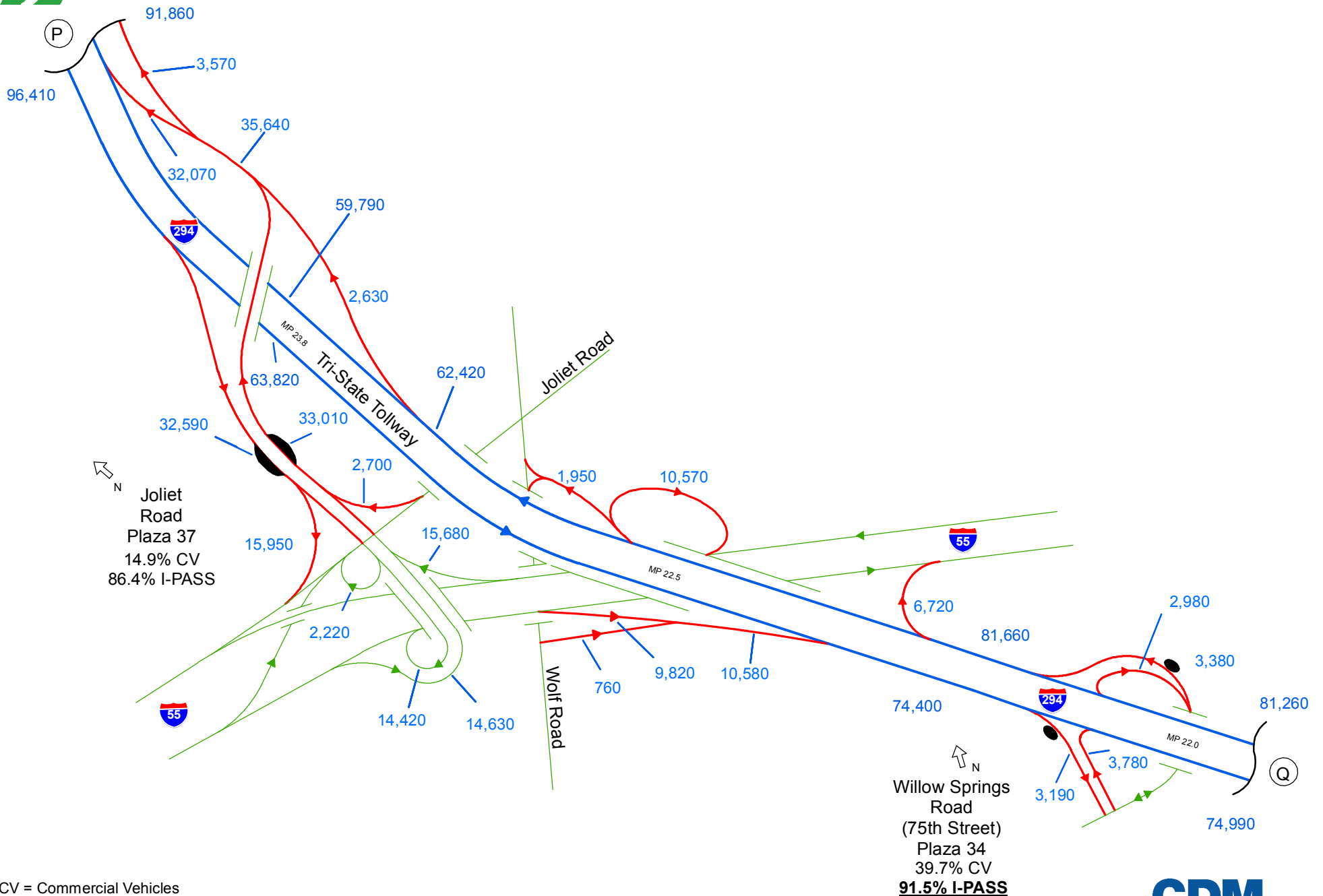

CV = Commercial Vehicles
 I-PASS = I-PASS Electronic Toll Collection
 ORT = Open Road Tolling Lanes
 AET = All Electronic Tolling





2016 Annual Average Daily Traffic

On Tri-State Tollway, from Archer / Lagrange / 79th Street to 147th Street (Plaza 42) / I-57

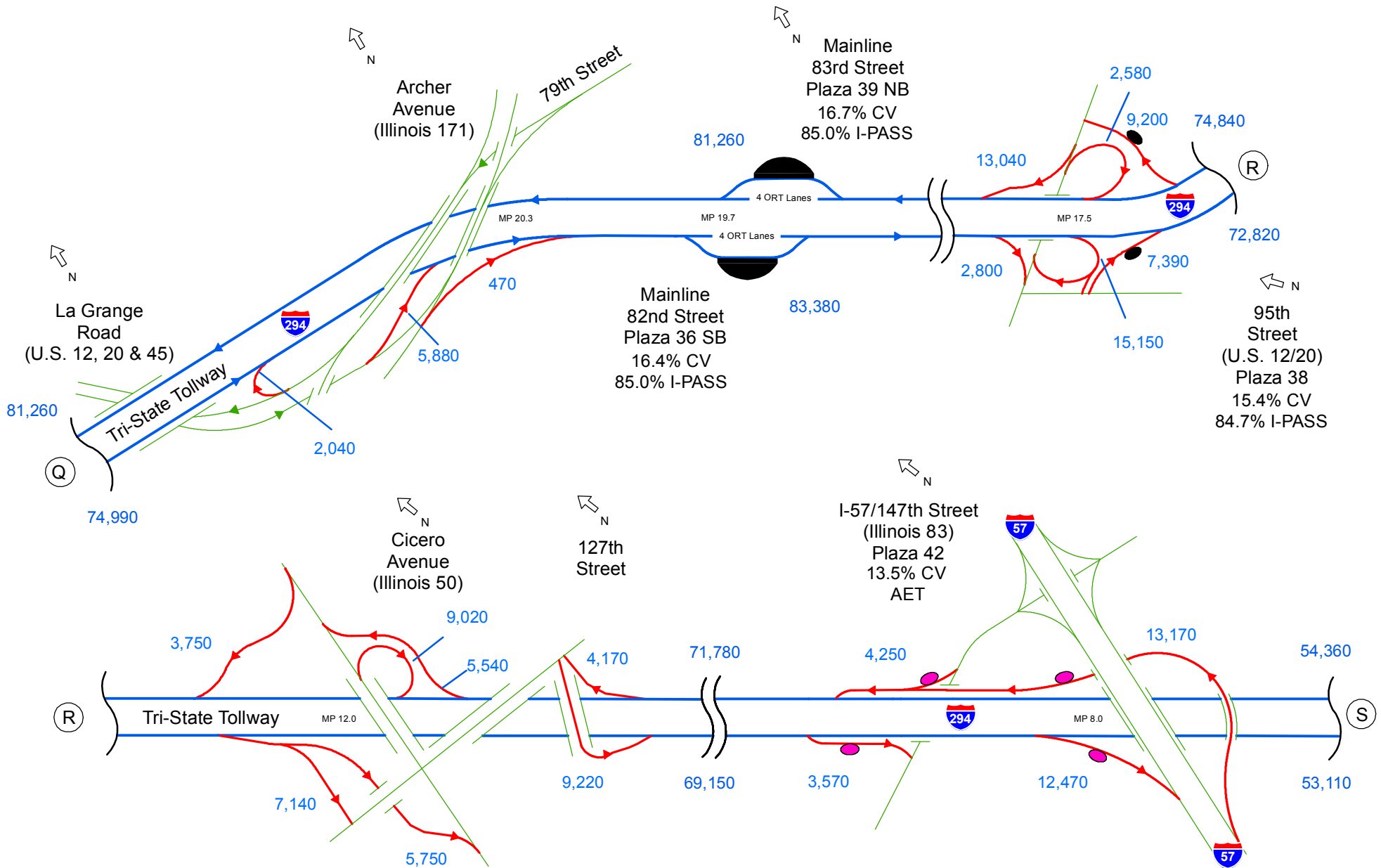

CV = Commercial Vehicles
 I-PASS = I-PASS Electronic Toll Collection
 ORT = Open Road Tolling Lanes
 AET = All Electronic Tolling





2016 Annual Average Daily Traffic

On Tri-State Tollway, from 159th Street (Plaza 40) to Bishop Ford / Kingery Expressway

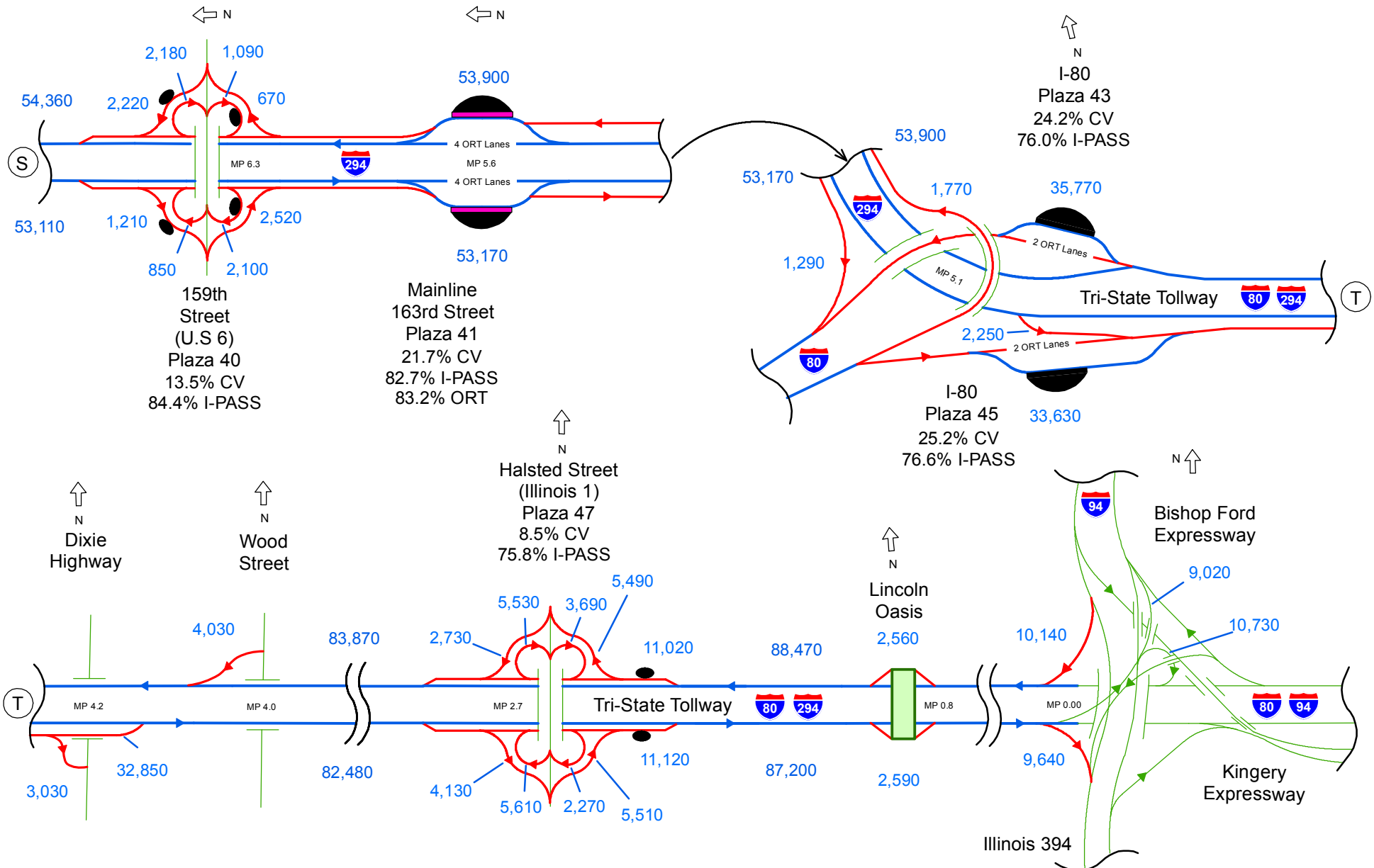

CV = Commercial Vehicles
 I-PASS = I-PASS Electronic Toll Collection
 ORT = Open Road Tolling Lanes
 AET = All Electronic Tolling



2016 Annual Average Daily Traffic

On Reagan Memorial Tollway, from Illinois 26 to Orchard Road

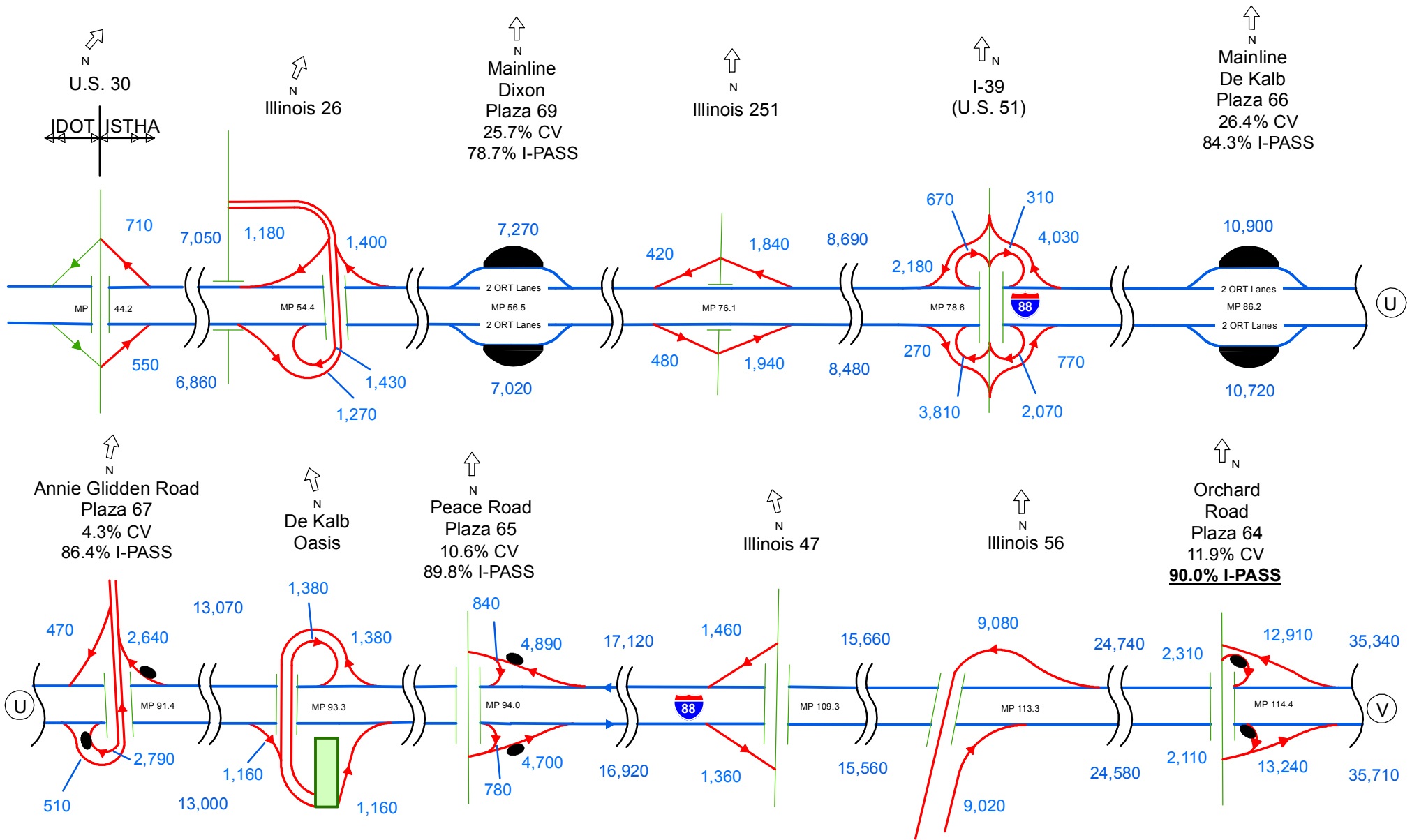

CV = Commercial Vehicles
 I-PASS = I-PASS Electronic Toll Collection
 ORT = Open Road Tolling Lanes
 AET = All Electronic Tolling





2016 Annual Average Daily Traffic

On Reagan Memorial Tollway, from Illinois 31 to Illinois 53

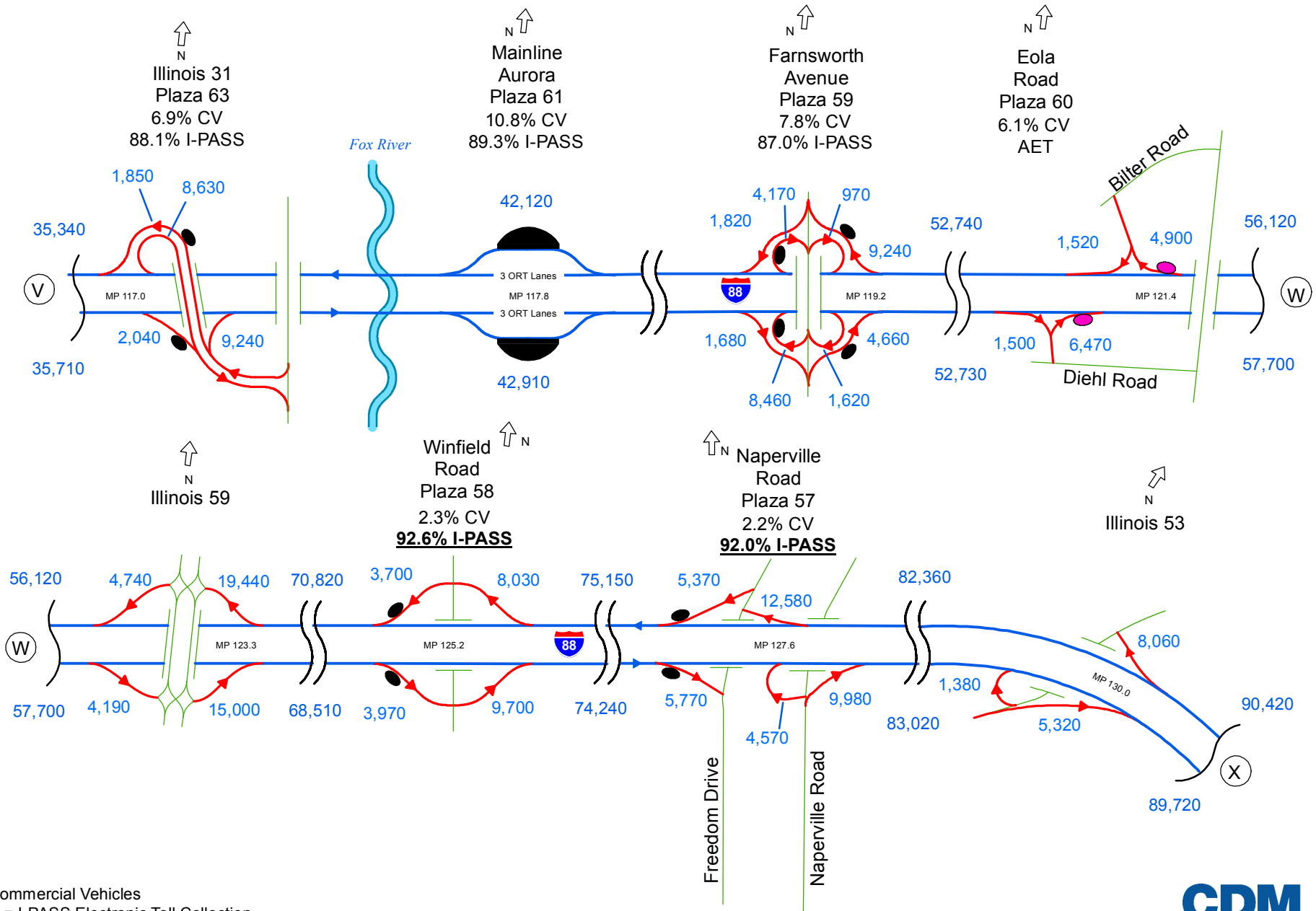

CV = Commercial Vehicles
 I-PASS = I-PASS Electronic Toll Collection
 ORT = Open Road Tolling Lanes
 AET = All Electronic Tolling





2016 Annual Average Daily Traffic

On Reagan Memorial Tollway, Veterans Memorial Tollway West Interchange

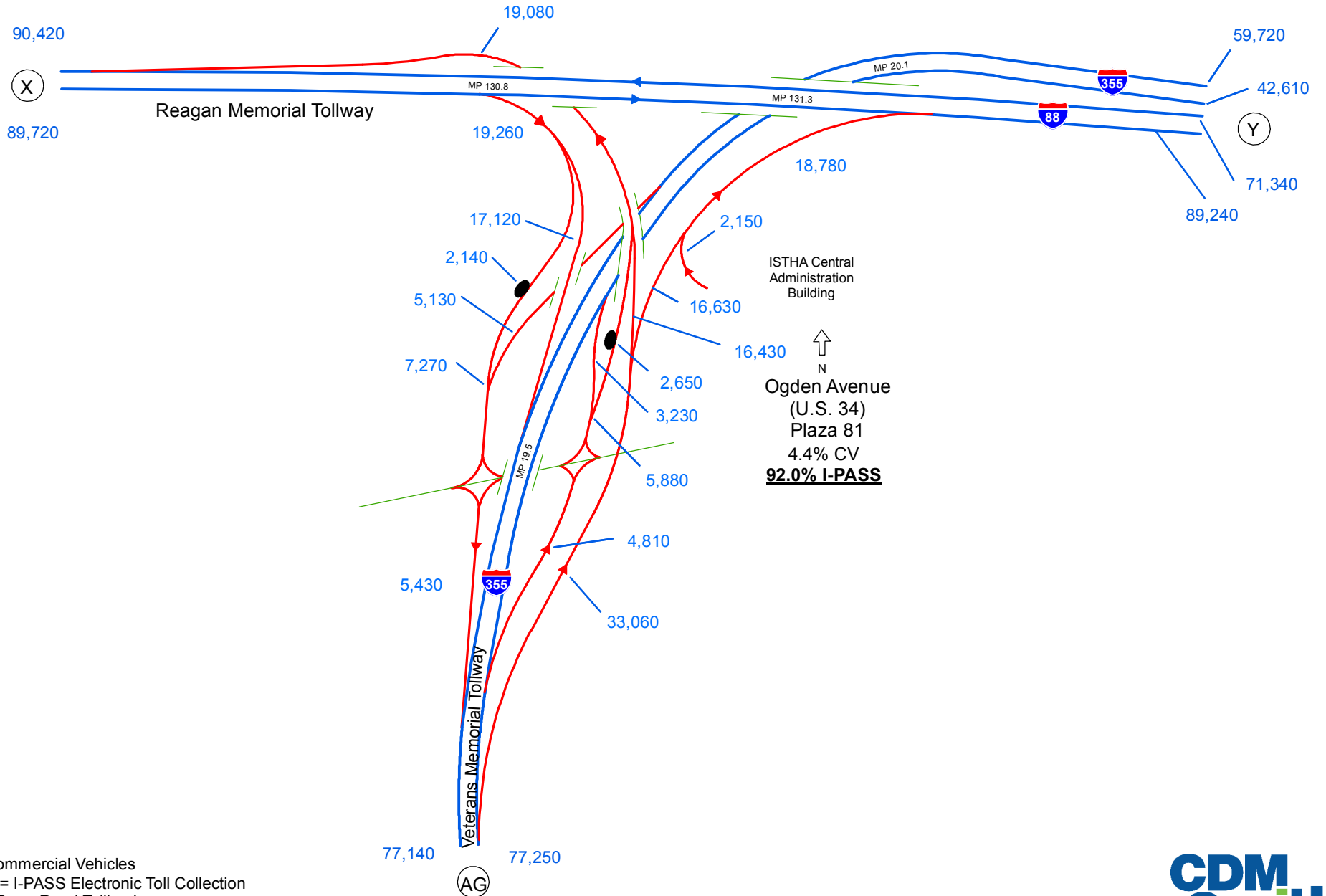

CV = Commercial Vehicles
 I-PASS = I-PASS Electronic Toll Collection
 ORT = Open Road Tolling Lanes
 AET = All Electronic Tolling





2016 Annual Average Daily Traffic

On Reagan Memorial Tollway, Veterans Memorial Tollway East Interchange

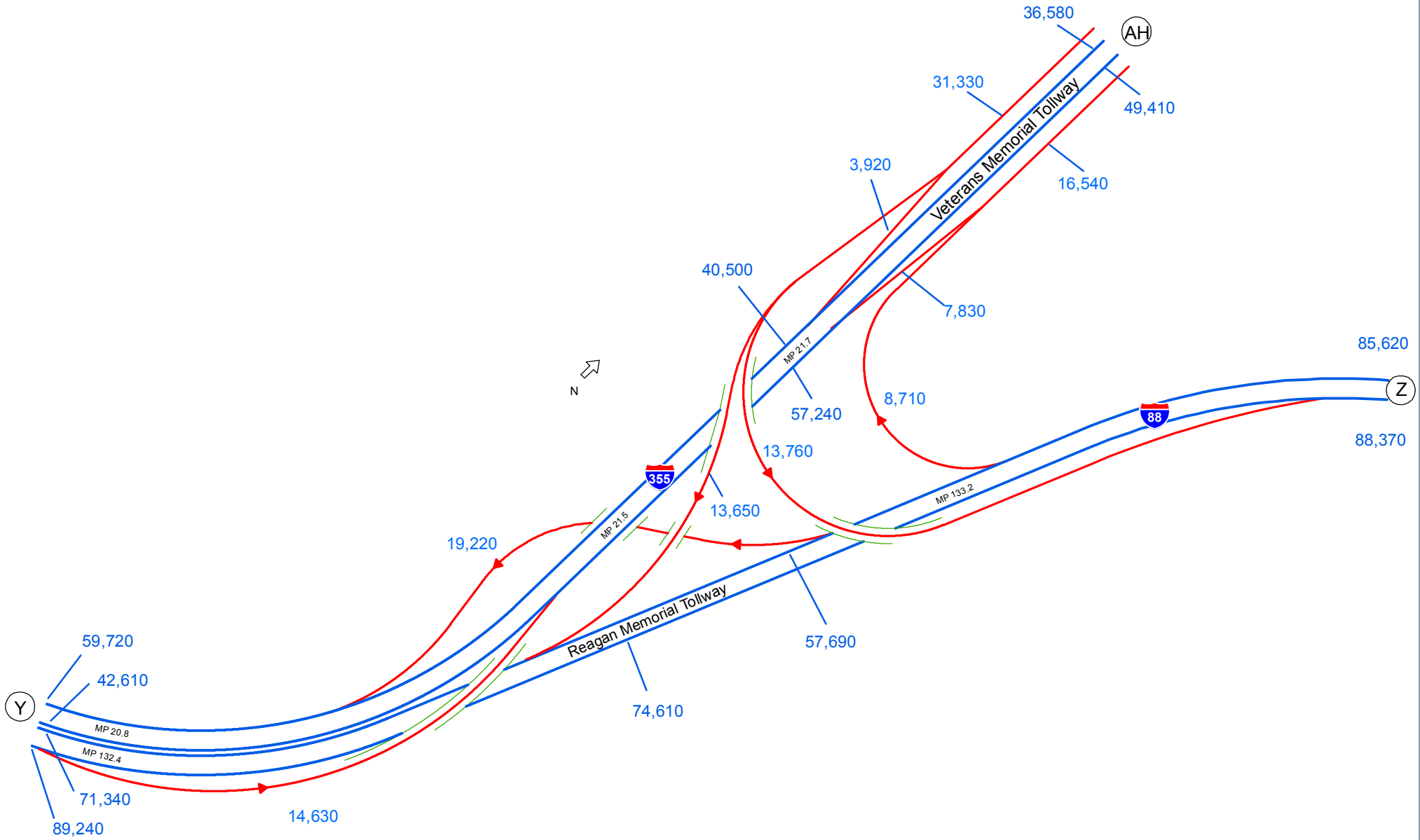

CV = Commercial Vehicles
 I-PASS = I-PASS Electronic Toll Collection
 ORT = Open Road Tolling Lanes
 AET = All Electronic Tolling





2016 Annual Average Daily Traffic

On Reagan Memorial Tollway, from Highland Avenue to Harger Road

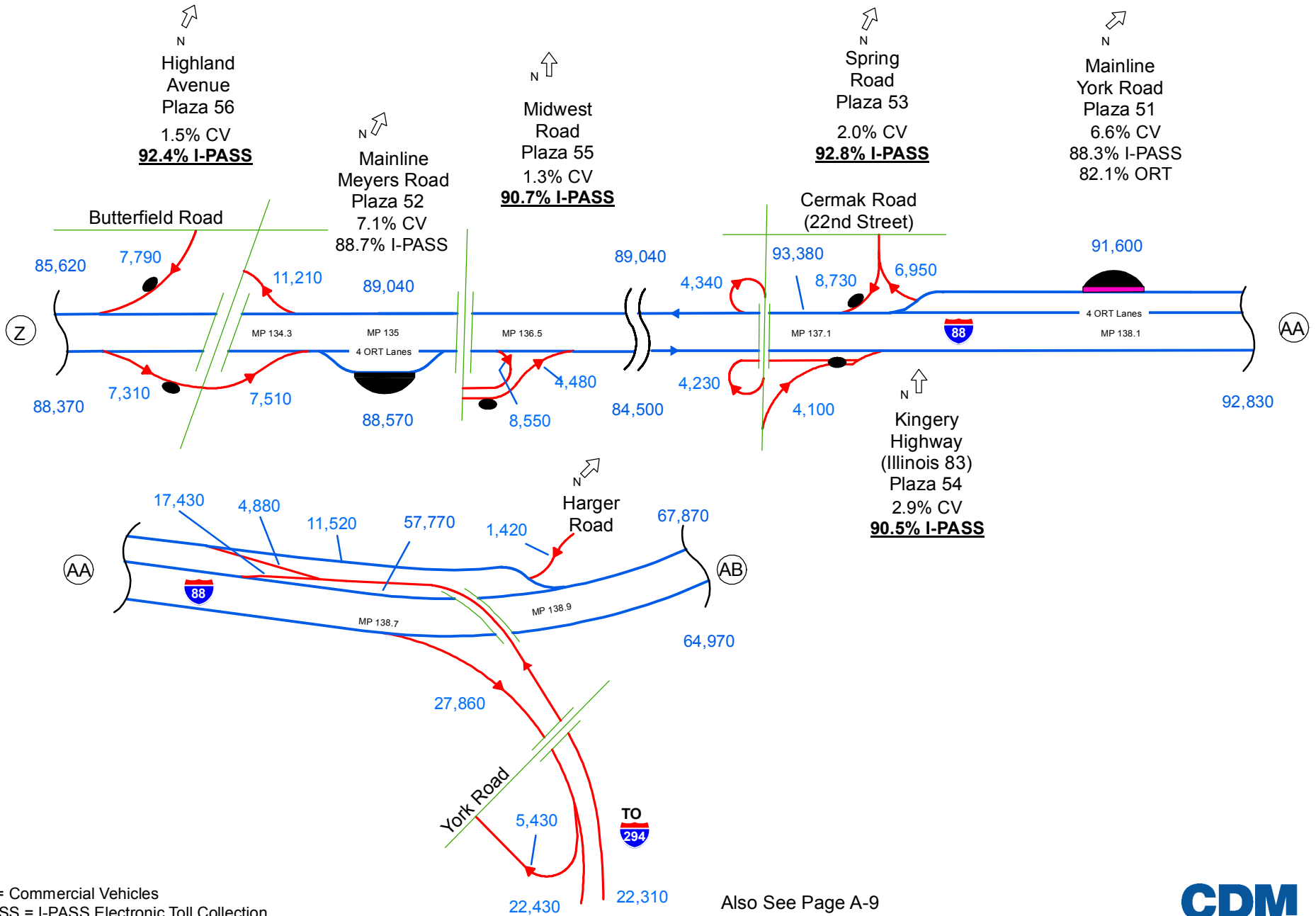

CV = Commercial Vehicles
 I-PASS = I-PASS Electronic Toll Collection
 ORT = Open Road Tolling Lanes
 AET = All Electronic Tolling

Also See Page A-9





2016 Annual Average Daily Traffic

On Reagan Memorial Tollway, from Roosevelt Road to Eisenhower Expressway (I-290)

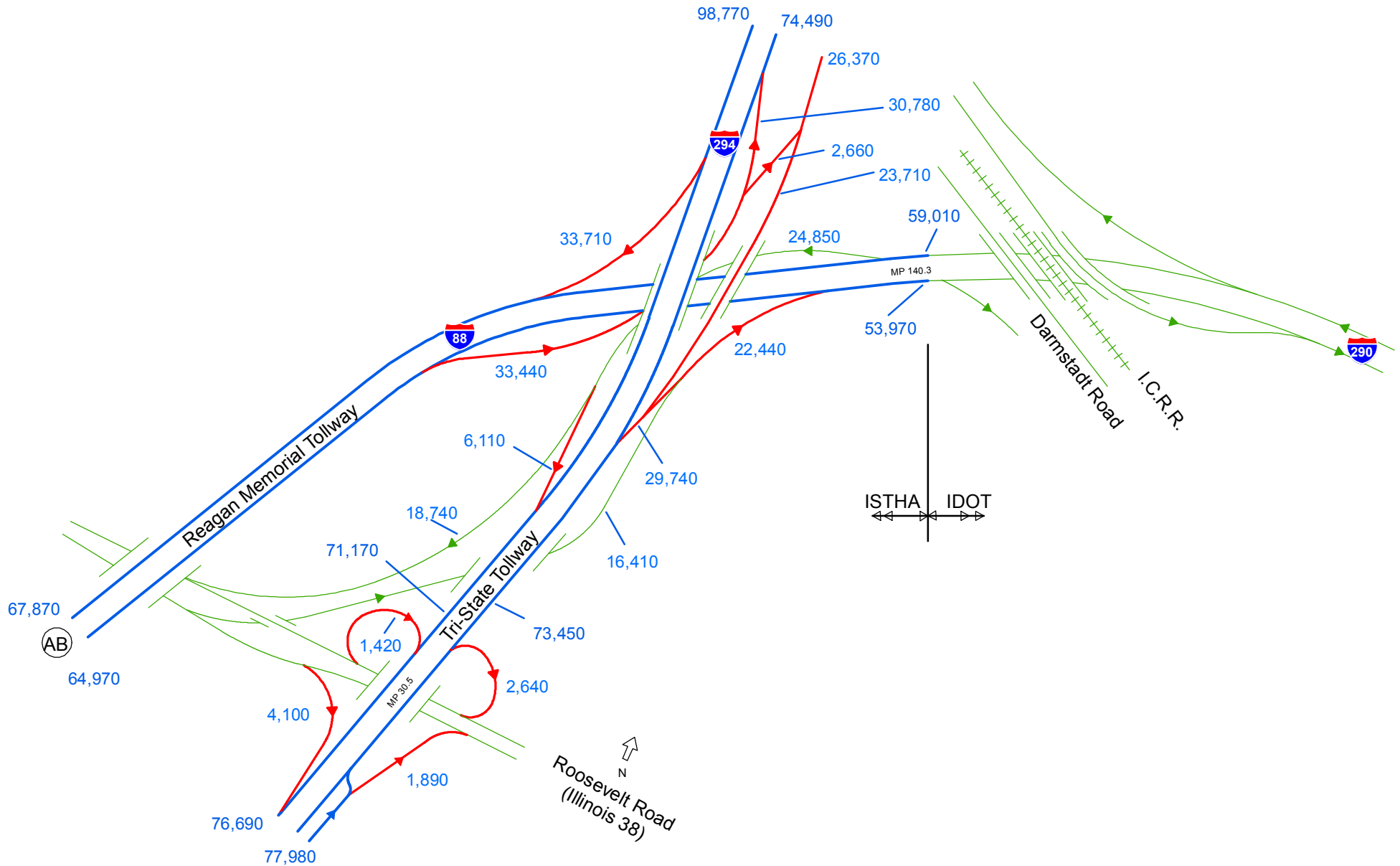

CV = Commercial Vehicles
 I-PASS = I-PASS Electronic Toll Collection
 ORT = Open Road Tolling Lanes
 AET = All Electronic Tolling





2016 Annual Average Daily Traffic

On Veterans Memorial Tollway, from Interstate 80 to 127th Street

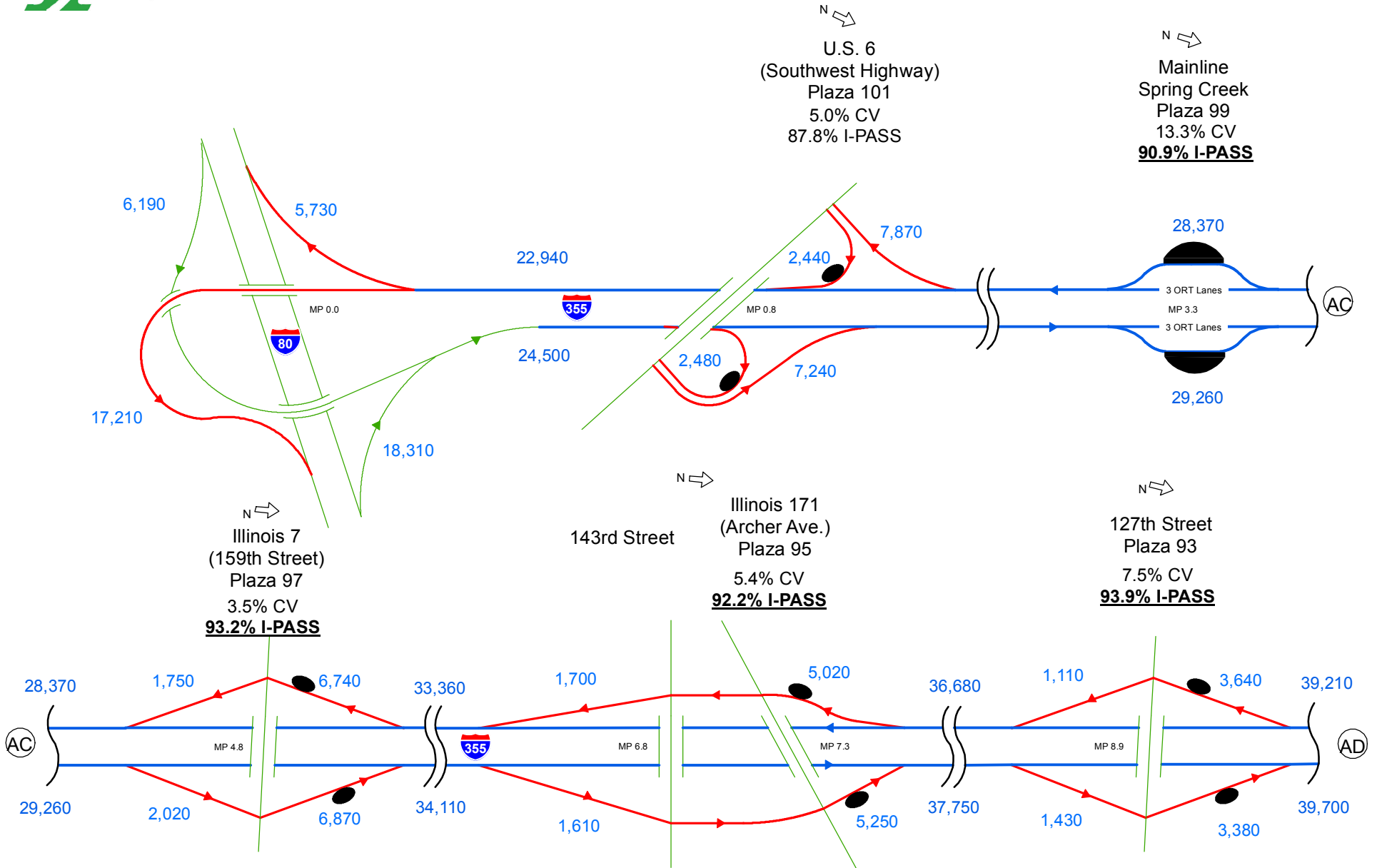

CV = Commercial Vehicles
 I-PASS = I-PASS Electronic Toll Collection
 ORT = Open Road Tolling Lanes
 AET = All Electronic Tolling





2016 Annual Average Daily Traffic

On Veterans Memorial Tollway, At Interstate 55

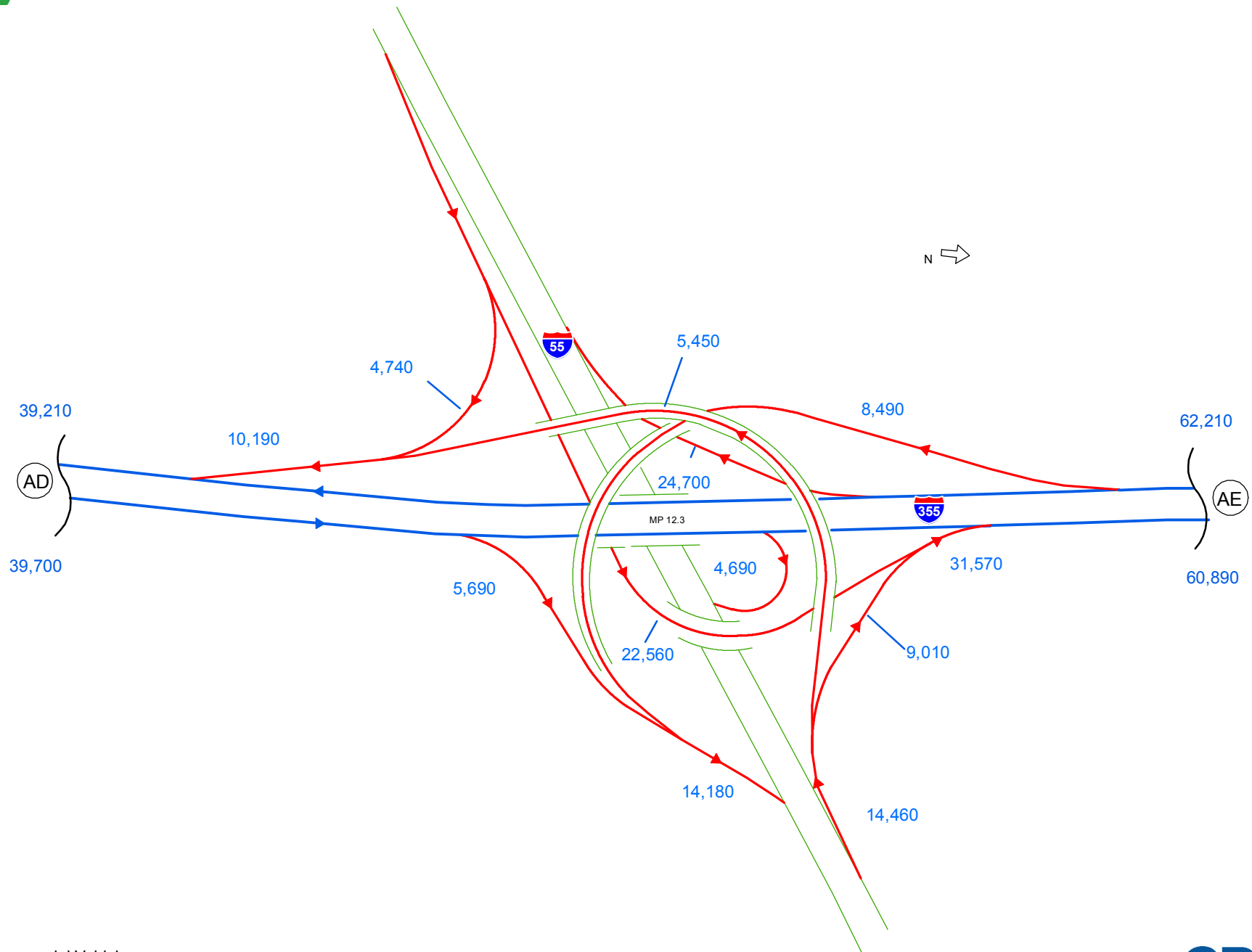

CV = Commercial Vehicles
I-PASS = I-PASS Electronic Toll Collection
ORT = Open Road Tolling Lanes
AET = All Electronic Tolling



2016 Annual Average Daily Traffic

On Veterans Memorial Tollway, from Boughton Road to Maple Avenue

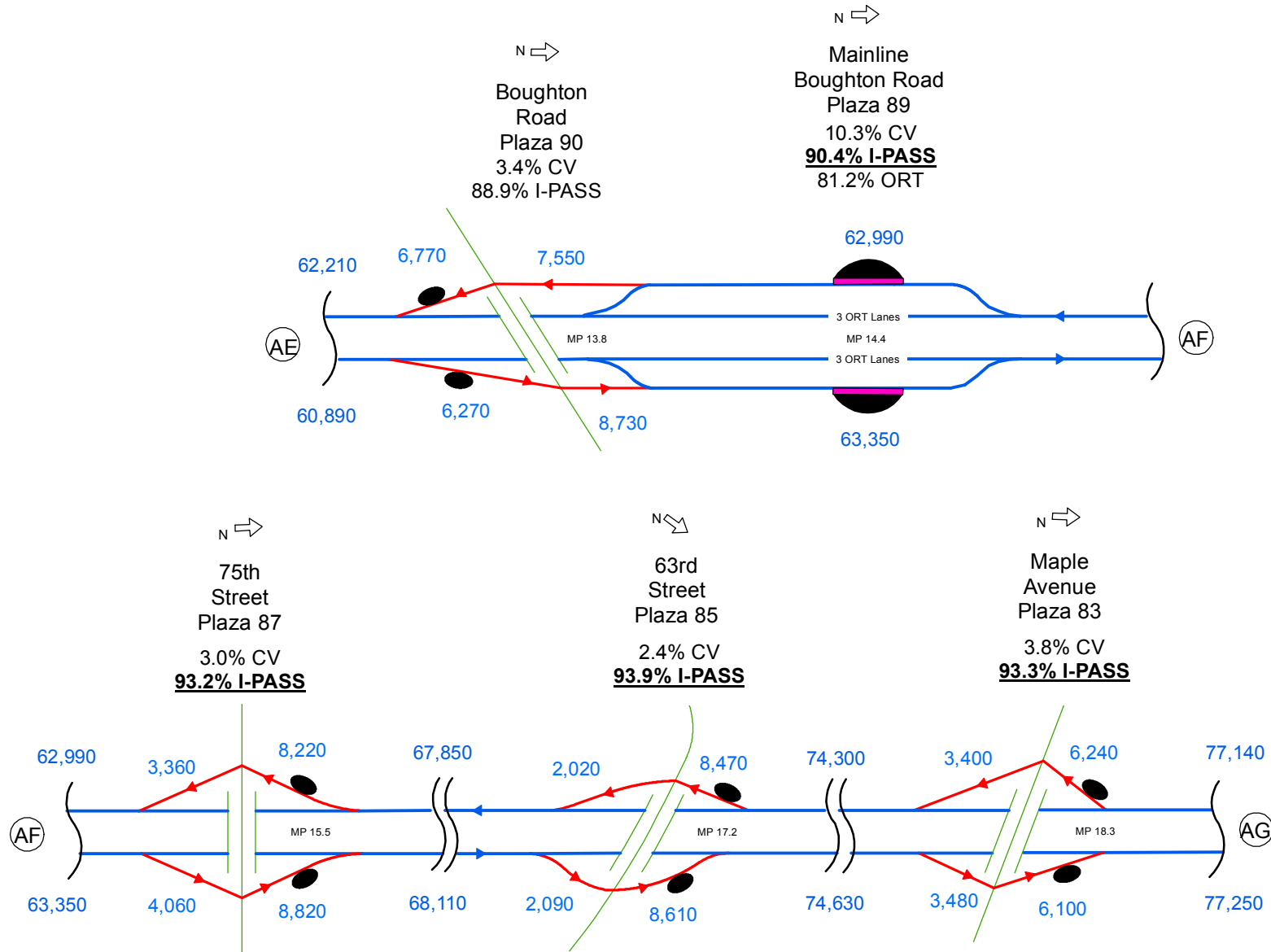

CV = Commercial Vehicles
 I-PASS = I-PASS Electronic Toll Collection
 ORT = Open Road Tolling Lanes
 AET = All Electronic Tolling





2016 Annual Average Daily Traffic

On Veterans Memorial Tollway, from Ogden Avenue / West Interchange to Army Trail Road

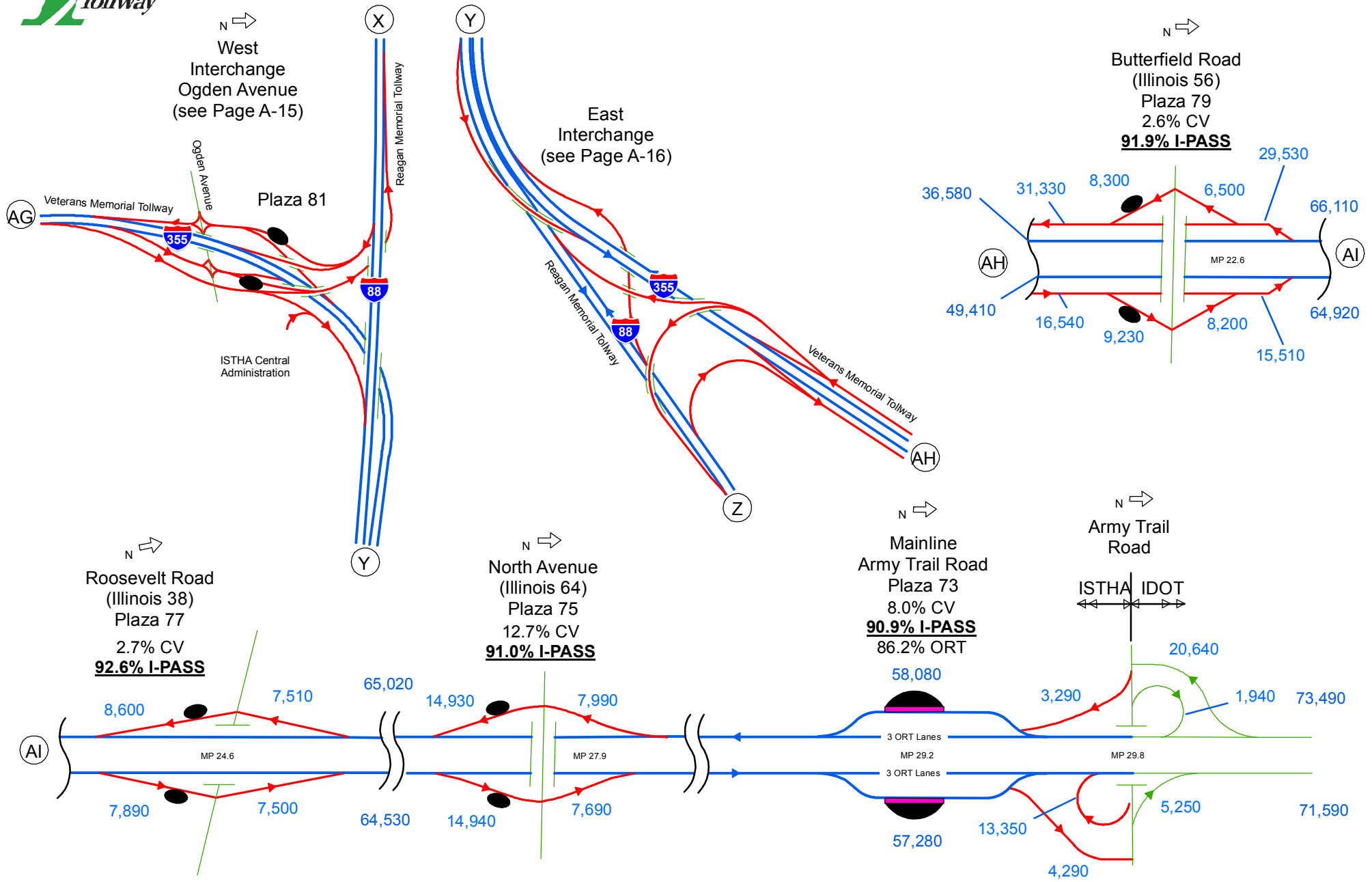

CV = Commercial Vehicles
 I-PASS = I-PASS Electronic Toll Collection
 ORT = Open Road Tolling Lanes
 AET = All Electronic Tolling





2016 Annual Average Daily Traffic

On IL 390, from Lake Street to Plum Grove Road (Plaza 326)

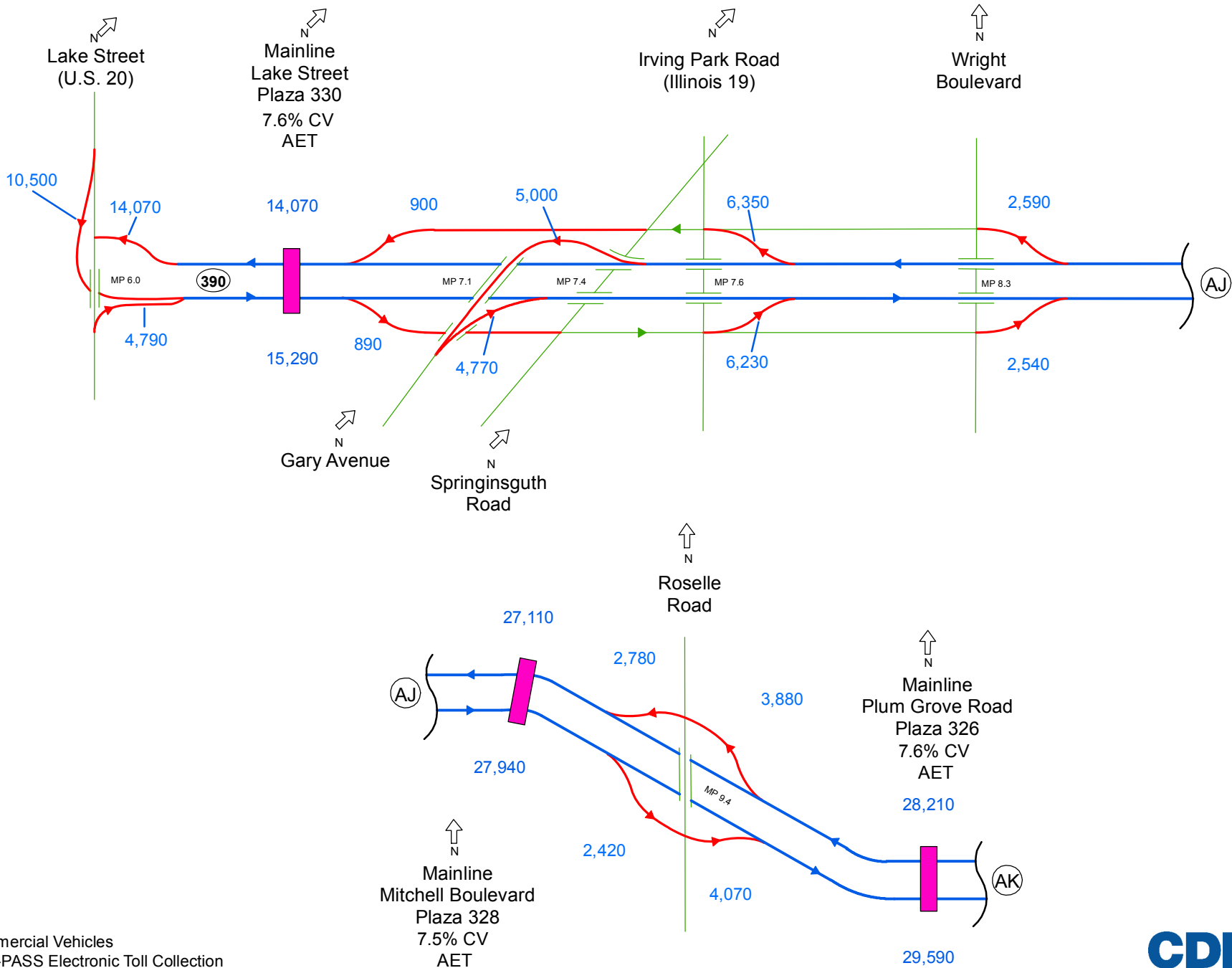

CV = Commercial Vehicles
 I-PASS = I-PASS Electronic Toll Collection
 ORT = Open Road Tolling Lanes
 AET = All Electronic Tolling





2016 Annual Average Daily Traffic

On IL 390, from Plum Grove Road (Plaza 326) to Interstate 290

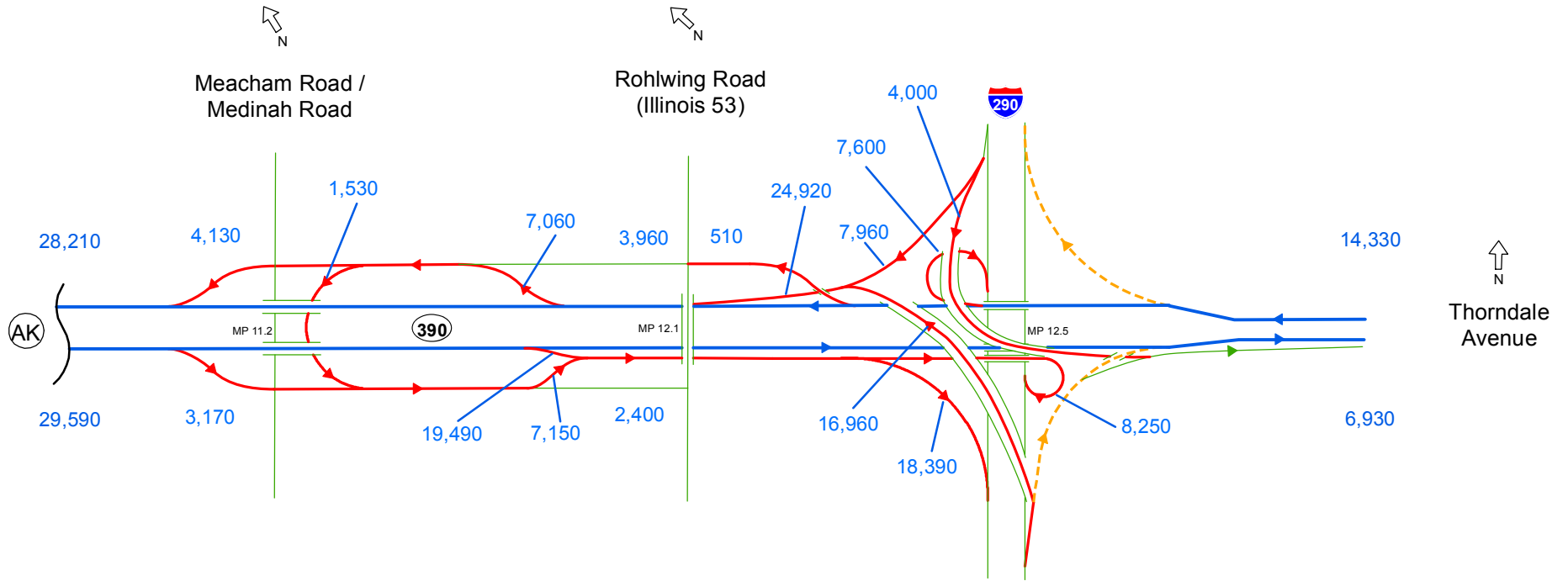

CV = Commercial Vehicles
 I-PASS = I-PASS Electronic Toll Collection
 ORT = Open Road Tolling Lanes
 AET = All Electronic Tolling





APPENDIX B

2016 SYSTEMWIDE A.M. AND P.M. PEAK HOUR TRAFFIC SCHEMATICS



2016 A.M. & P.M. Peak Hour Traffic

On Jane Addams Memorial Tollway, from Rockton Road to Marengo (Plaza 7)

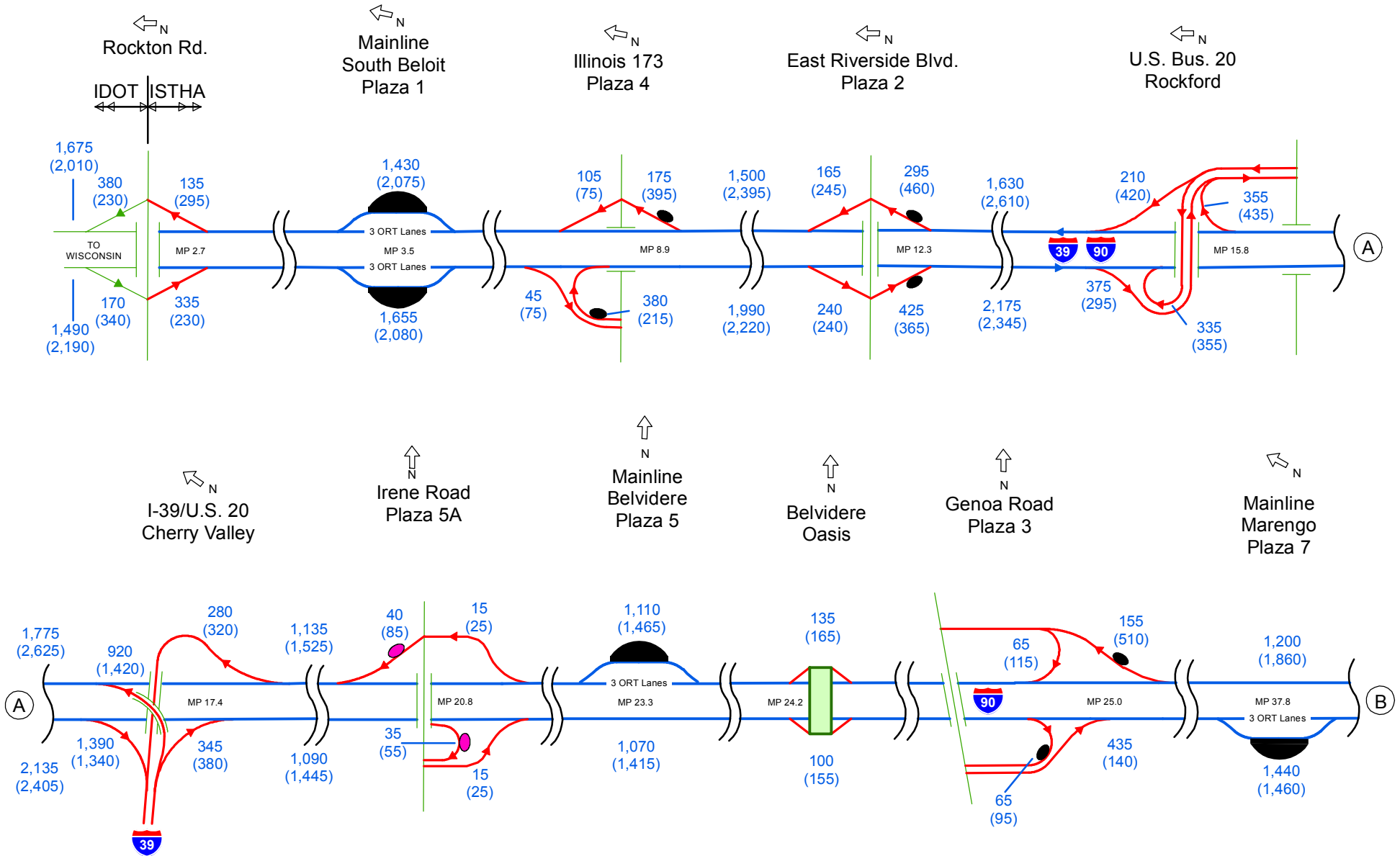

Note:
The 2016 AM & PM peak-hour volumes are defined as the 85th Percentile volumes occurring in the 6:00 to 8:00 AM and the 4:00 to 6:00 PM periods respectively. Peak-hour volumes are calculated from Monday through Thursday hourly traffic volume data only, and exclude holidays.





2016 A.M. & P.M. Peak Hour Traffic

On Jane Addams Memorial Tollway, from U.S. 20, Marengo to Barrington Road

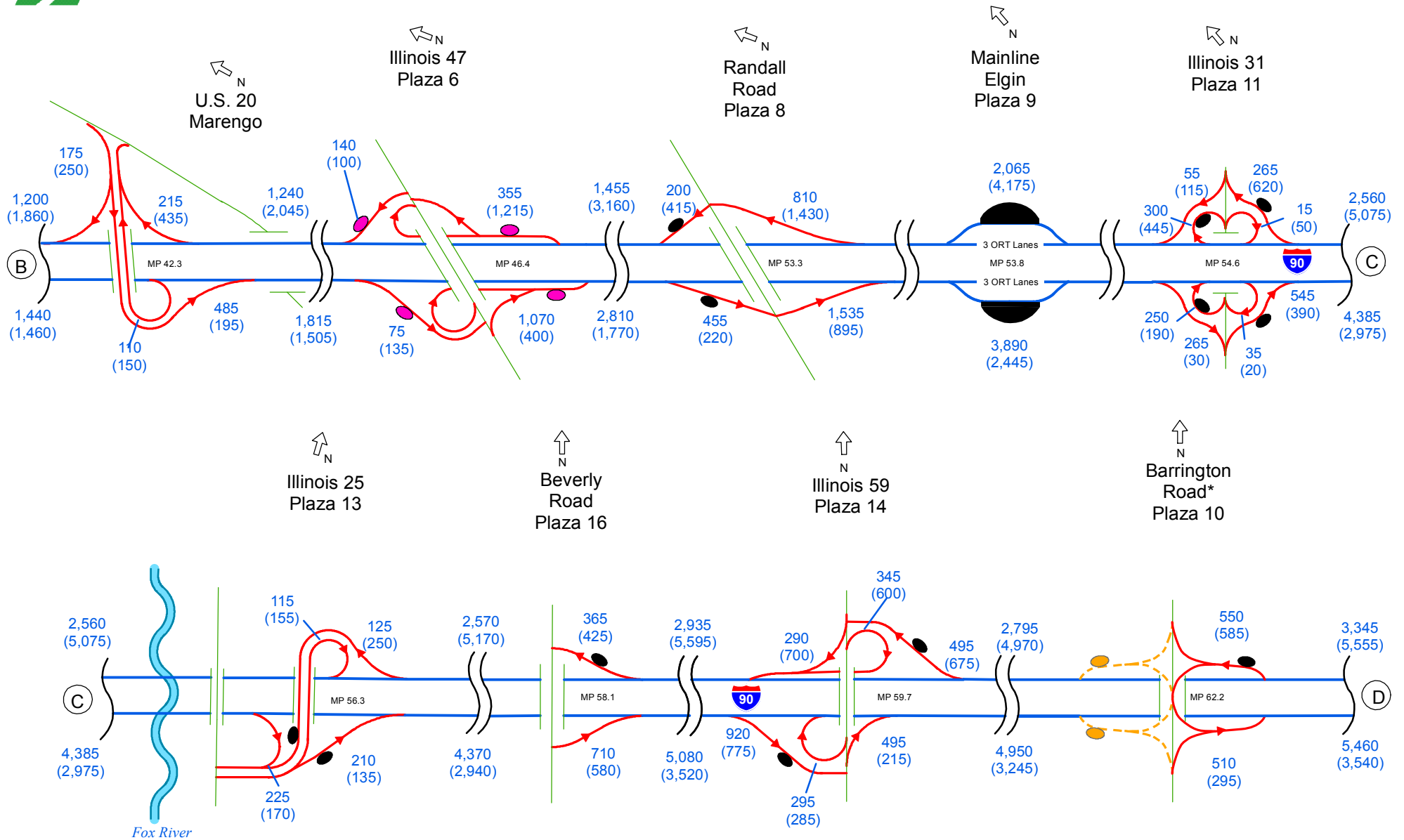

*New ramps at Barrington Road were under construction in 2016.

Note:
The 2016 AM & PM peak-hour volumes are defined as the 85th Percentile volumes occurring in the 6:00 to 8:00 AM and the 4:00 to 6:00 PM periods respectively. Peak-hour volumes are calculated from Monday through Thursday hourly traffic volume data only, and exclude holidays.





2016 A.M. & P.M. Peak Hour Traffic

On Jane Addams Memorial Tollway, from Roselle Road to Devon Avenue

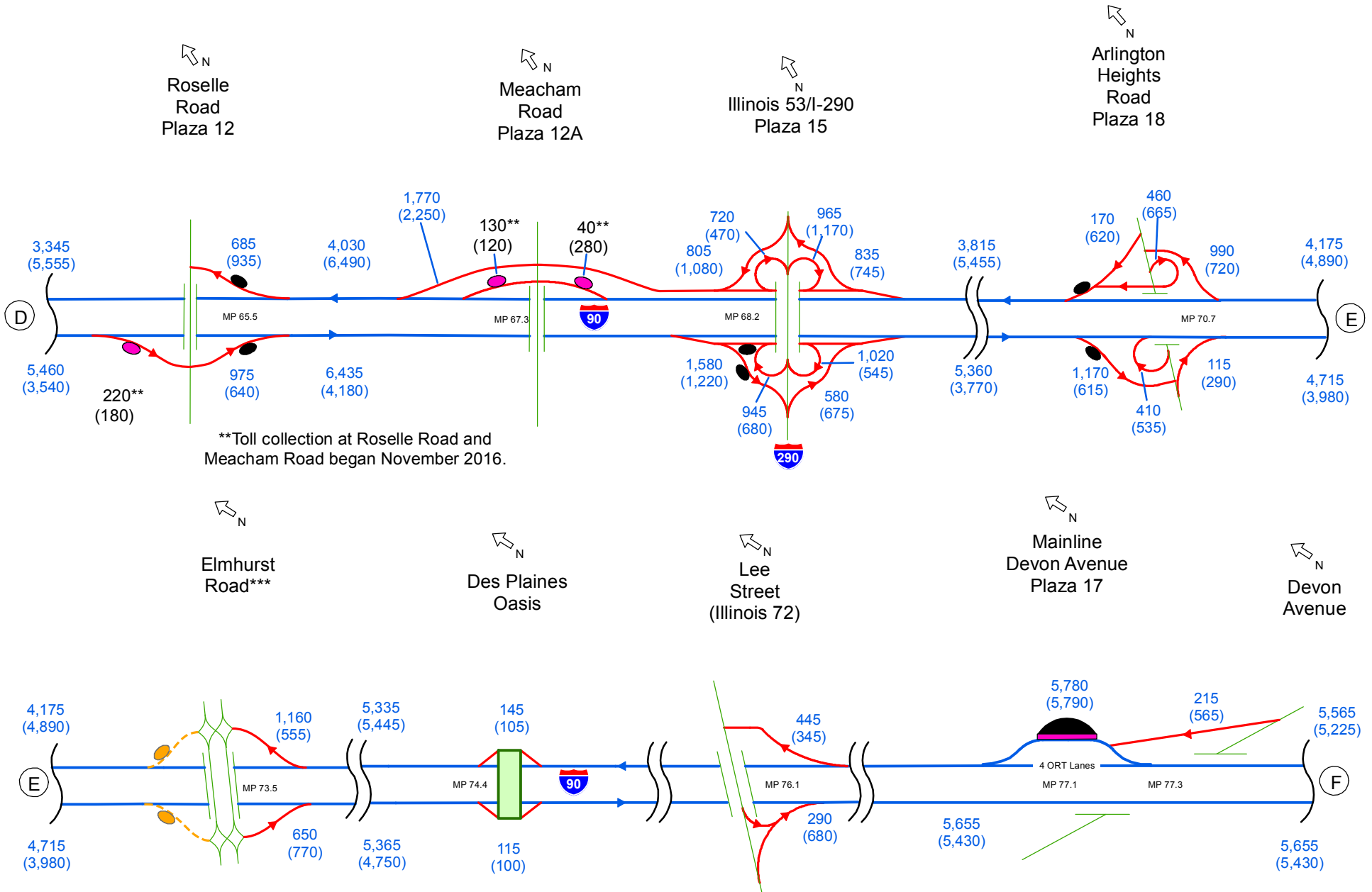

Note:
The 2016 AM & PM peak-hour volumes are defined as the 85th Percentile volumes occurring in the 6:00 to 8:00 AM and the 4:00 to 6:00 PM periods respectively. Peak-hour volumes are calculated from Monday through Thursday hourly traffic volume data only, and exclude holidays.



2016 A.M. & P.M. Peak Hour Traffic

On Jane Addams Memorial Tollway, from Tri-State Tollway to Kennedy Expressway

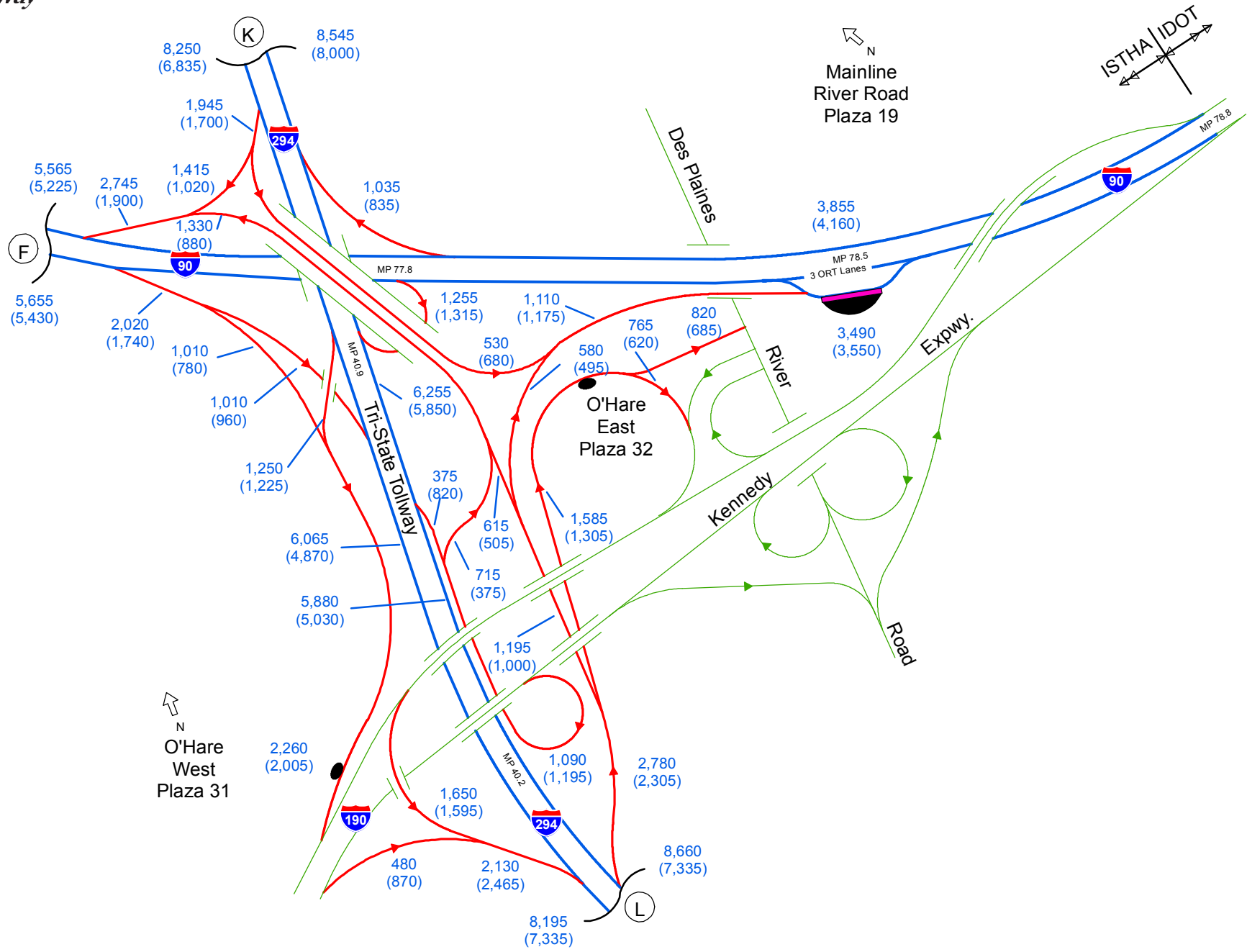

Note:
The 2016 AM & PM peak-hour volumes are defined as the 85th Percentile volumes occurring in the 6:00 to 8:00 AM and the 4:00 to 6:00 PM periods respectively. Peak-hour volumes are calculated from Monday through Thursday hourly traffic volume data only, and exclude holidays.

*,*** = A.M. Peak
(*,***) = P.M. Peak





2016 A.M. & P.M. Peak Hour Traffic

On Tri-State Tollway, from Russell Road to Lake Forest Oasis

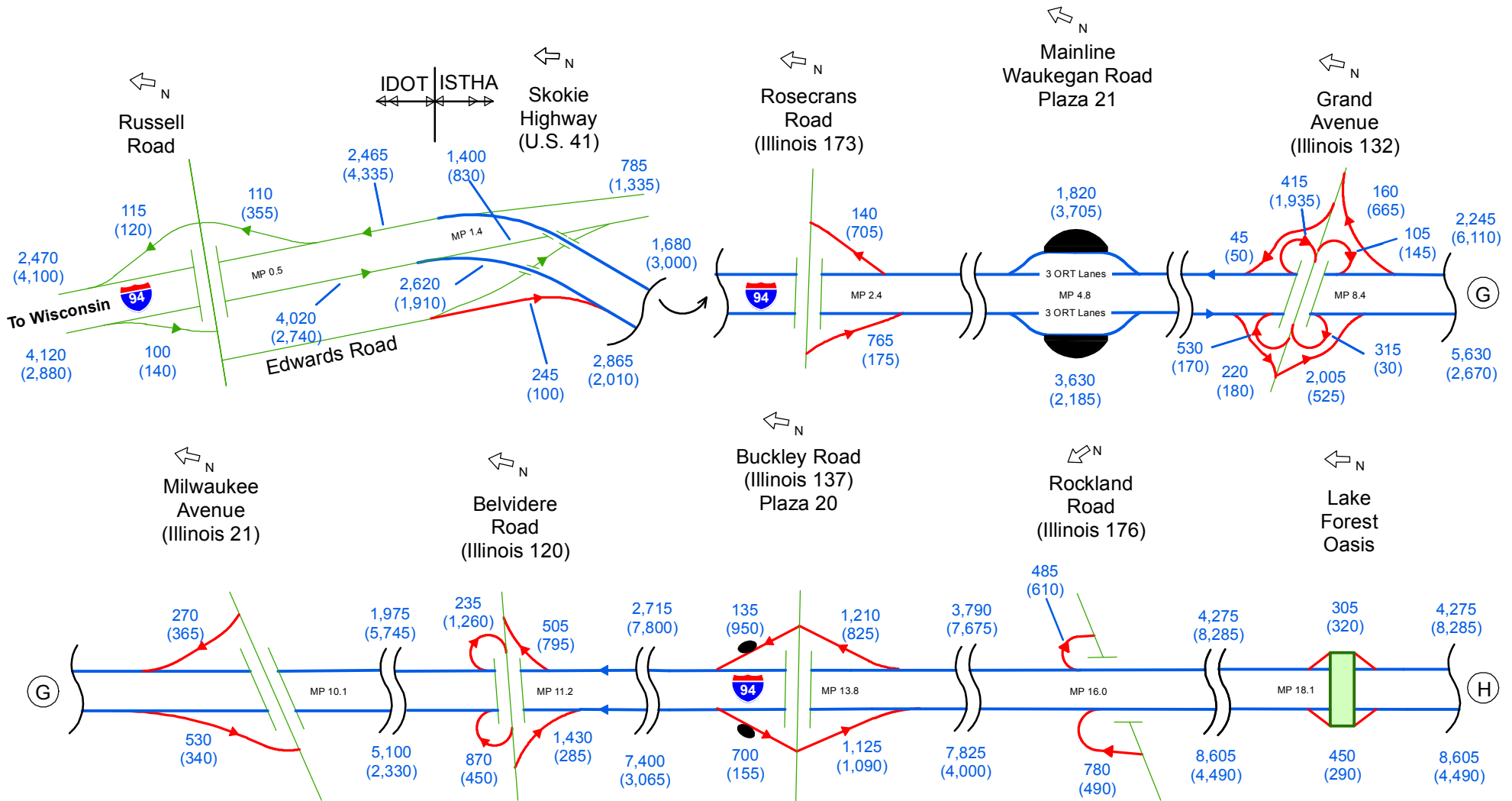

Note:
The 2016 AM & PM peak-hour volumes are defined as the 85th Percentile volumes occurring in the 6:00 to 8:00 AM and the 4:00 to 6:00 PM periods respectively. Peak-hour volumes are calculated from Monday through Thursday hourly traffic volume data only, and exclude holidays.



2016 A.M. & P.M. Peak Hour Traffic

On Tri-State Tollway, from Town Line Road (Illinois 60) to Golf Road (Illinois 58) and Edens Spur

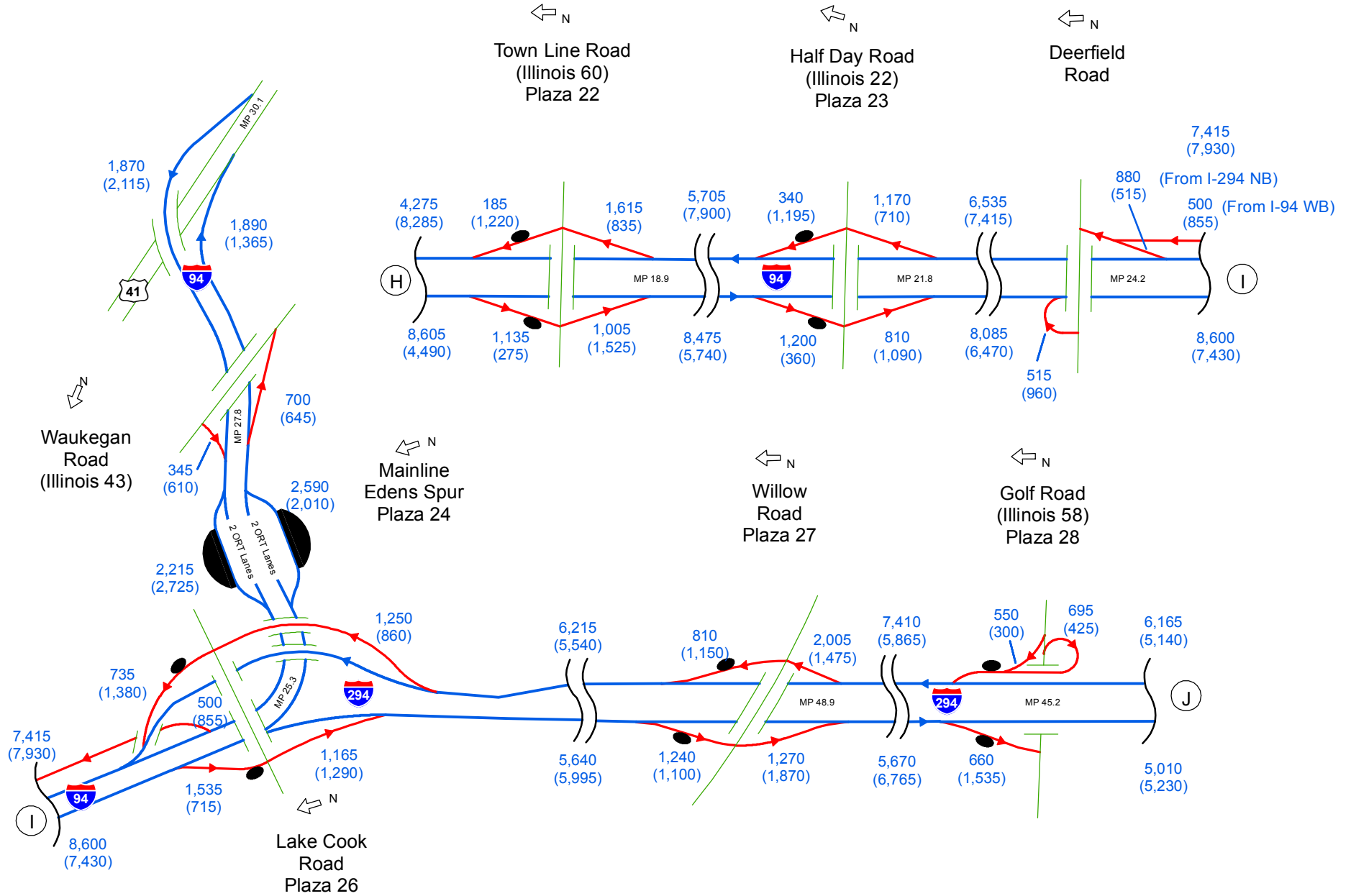

Note:
The 2016 AM & PM peak-hour volumes are defined as the 85th Percentile volumes occurring in the 6:00 to 8:00 AM and the 4:00 to 6:00 PM periods respectively. Peak-hour volumes are calculated from Monday through Thursday hourly traffic volume data only, and exclude holidays.



2016 A.M. & P.M. Peak Hour Traffic

On Tri-State Tollway, from Dempster Street to O'Hare Oasis

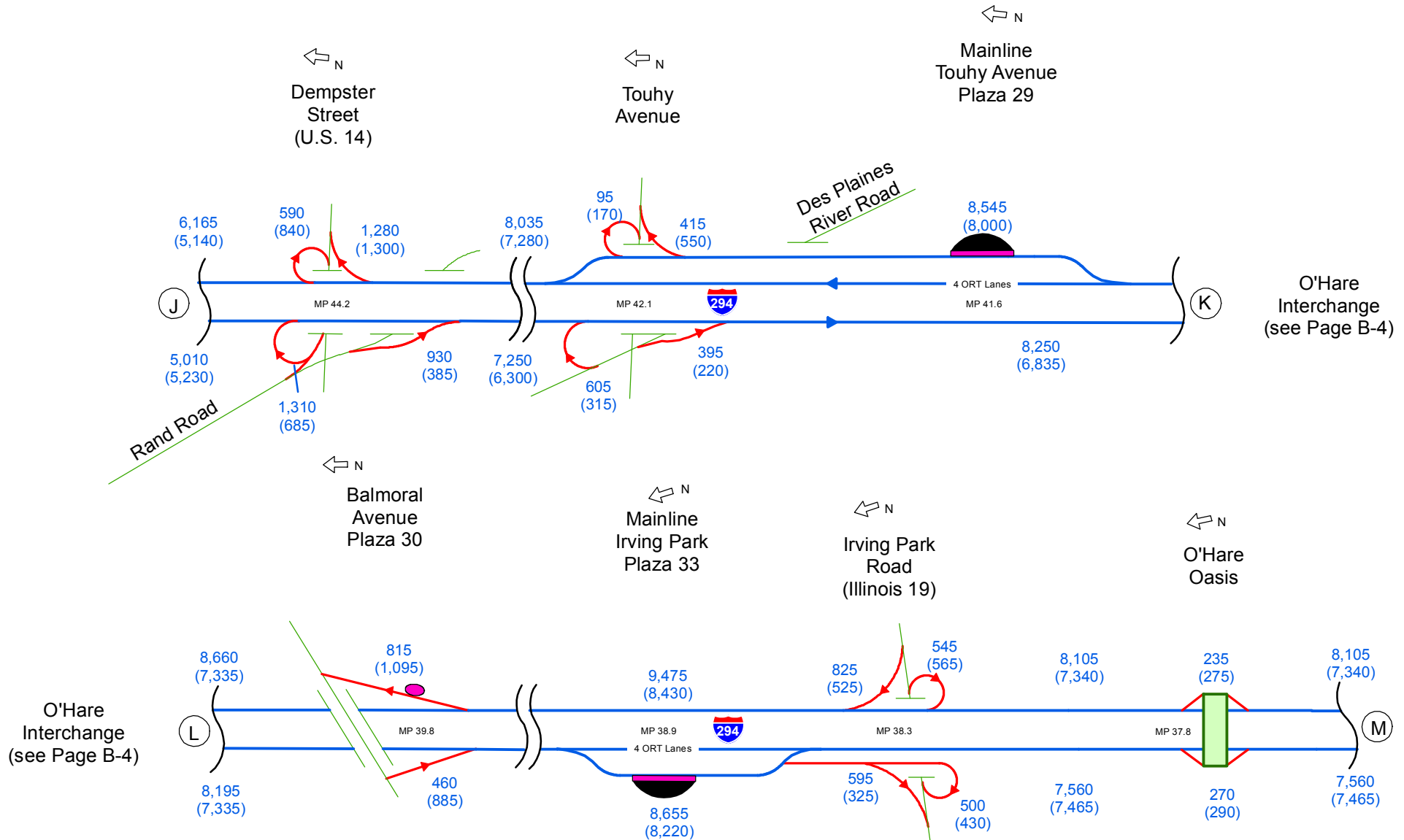

Note:
The 2016 AM & PM peak-hour volumes are defined as the 85th Percentile volumes occurring in the 6:00 to 8:00 AM and the 4:00 to 6:00 PM periods respectively. Peak-hour volumes are calculated from Monday through Thursday hourly traffic volume data only, and exclude holidays.



2016 A.M. & P.M. Peak Hour Traffic

On Tri-State Tollway, from North Avenue / Lake Street to Reagan Memorial Tollway (I-88)

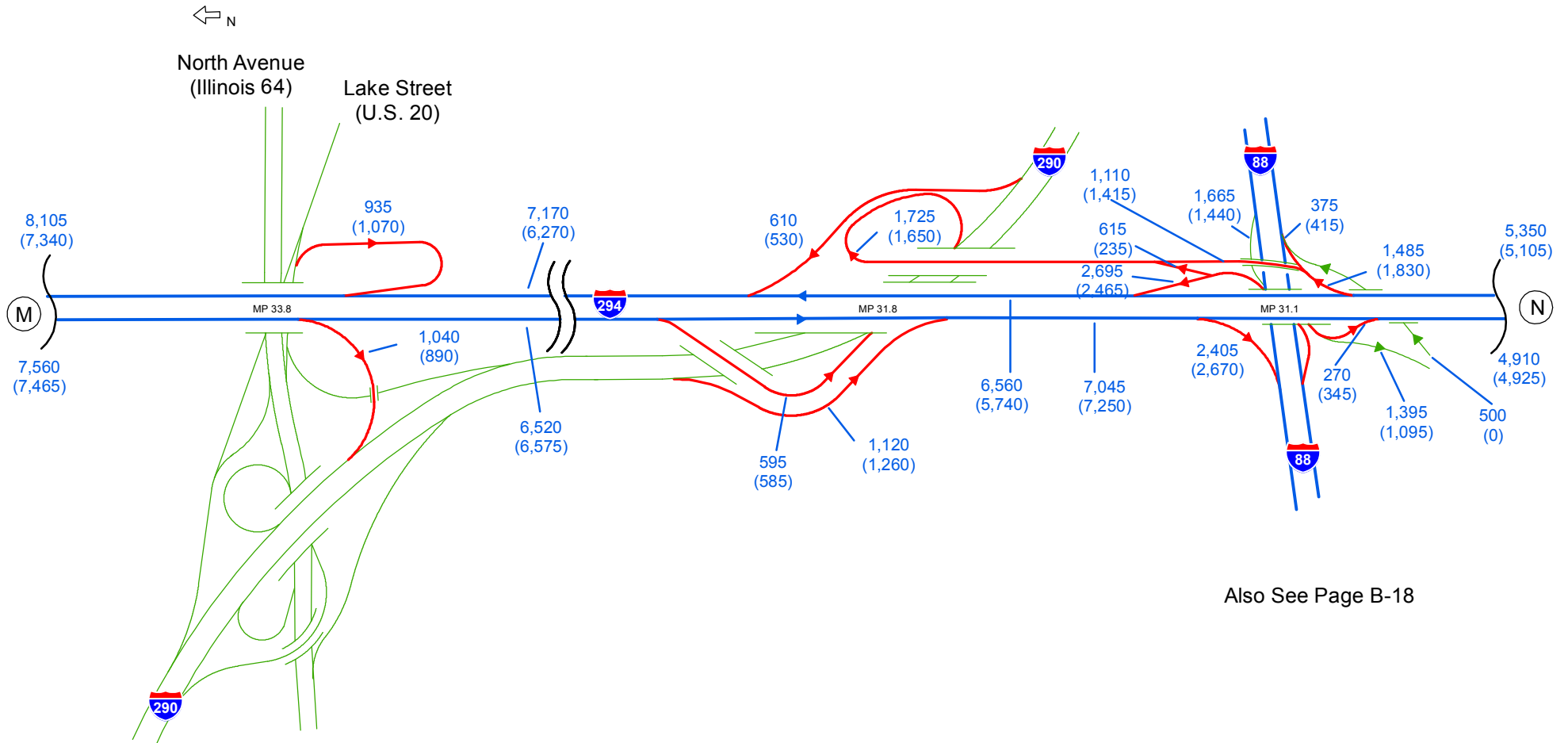

Also See Page B-18

Note:
The 2016 AM & PM peak-hour volumes are defined as the 85th Percentile volumes occurring in the 6:00 to 8:00 AM and the 4:00 to 6:00 PM periods respectively. Peak-hour volumes are calculated from Monday through Thursday hourly traffic volume data only, and exclude holidays.



2016 A.M. & P.M. Peak Hour Traffic

On Tri-State Tollway, from Roosevelt Road to Hinsdale Oasis

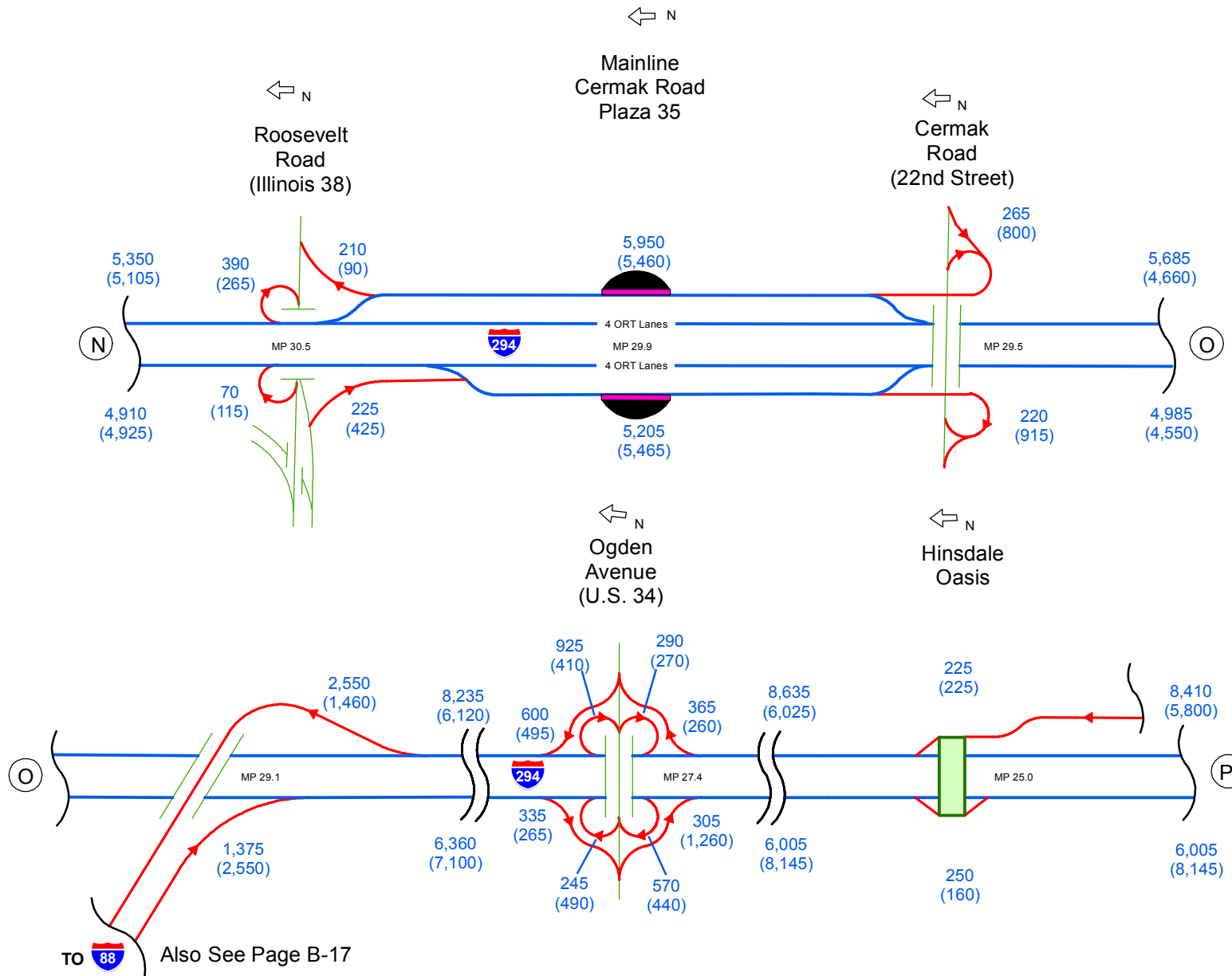

Note:
The 2016 AM & PM peak-hour volumes are defined as the 85th Percentile volumes occurring in the 6:00 to 8:00 AM and the 4:00 to 6:00 PM periods respectively. Peak-hour volumes are calculated from Monday through Thursday hourly traffic volume data only, and exclude holidays.



2016 A.M. & P.M. Peak Hour Traffic

On Tri-State Tollway, from Joliet Road (Plaza 37) to Willow Springs Road (Plaza 34)

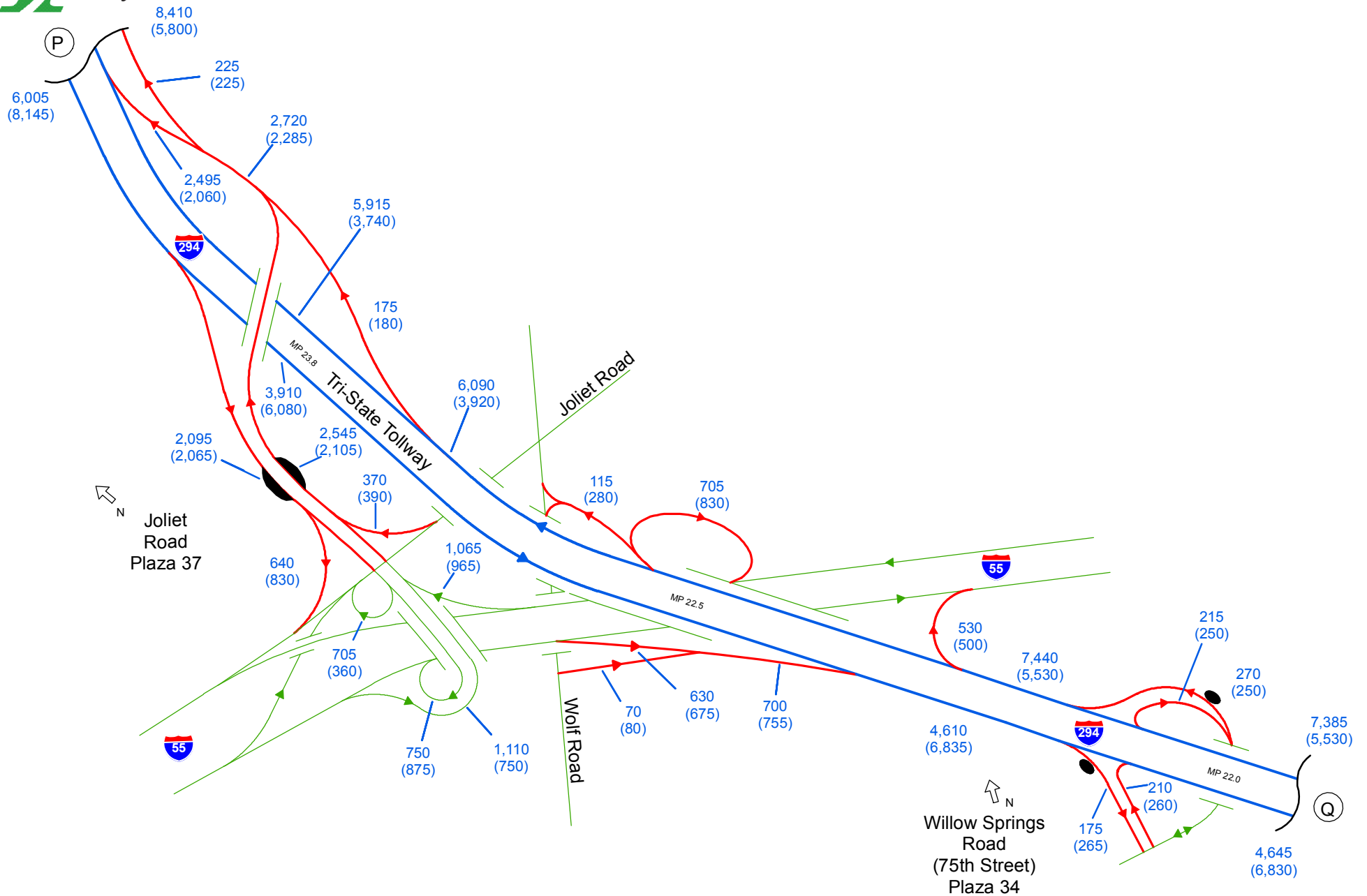

Note:
 The 2016 AM & PM peak-hour volumes are defined as the 85th Percentile volumes occurring in the 6:00 to 8:00 AM and the 4:00 to 6:00 PM periods respectively. Peak-hour volumes are calculated from Monday through Thursday hourly traffic volume data only, and exclude holidays.



2016 A.M. & P.M. Peak Hour Traffic

On Tri-State Tollway, from Archer / Lagrange / 79th Street to 147th Street (Plaza 42) / I-57

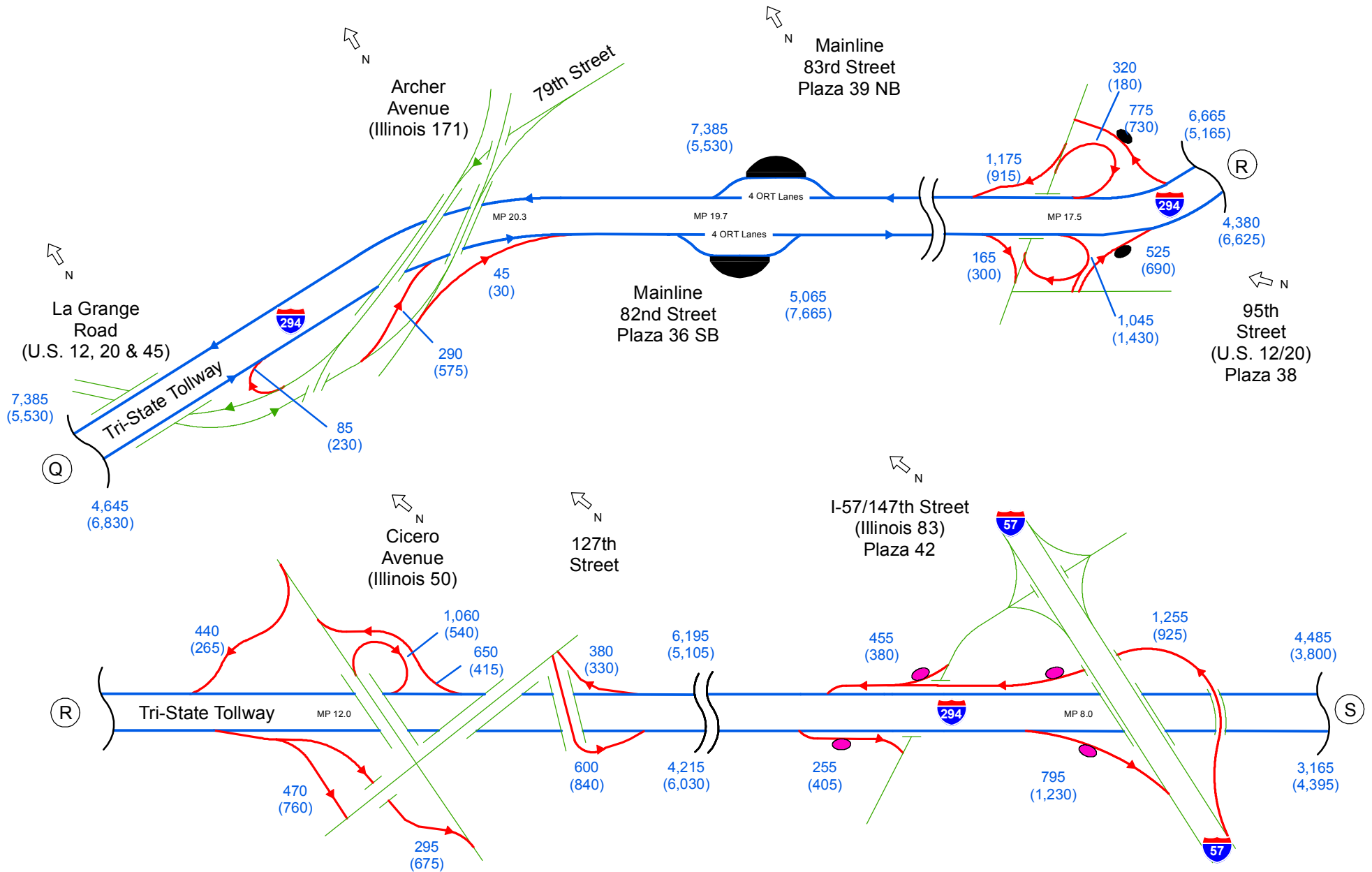

Note:
The 2016 AM & PM peak-hour volumes are defined as the 85th Percentile volumes occurring in the 6:00 to 8:00 AM and the 4:00 to 6:00 PM periods respectively. Peak-hour volumes are calculated from Monday through Thursday hourly traffic volume data only, and exclude holidays.

*** = A.M. Peak
(*,***) = P.M. Peak





2016 A.M. & P.M. Peak Hour Traffic

On Tri-State Tollway, from 159th Street (Plaza 40) to Bishop Ford / Kingery Expressway

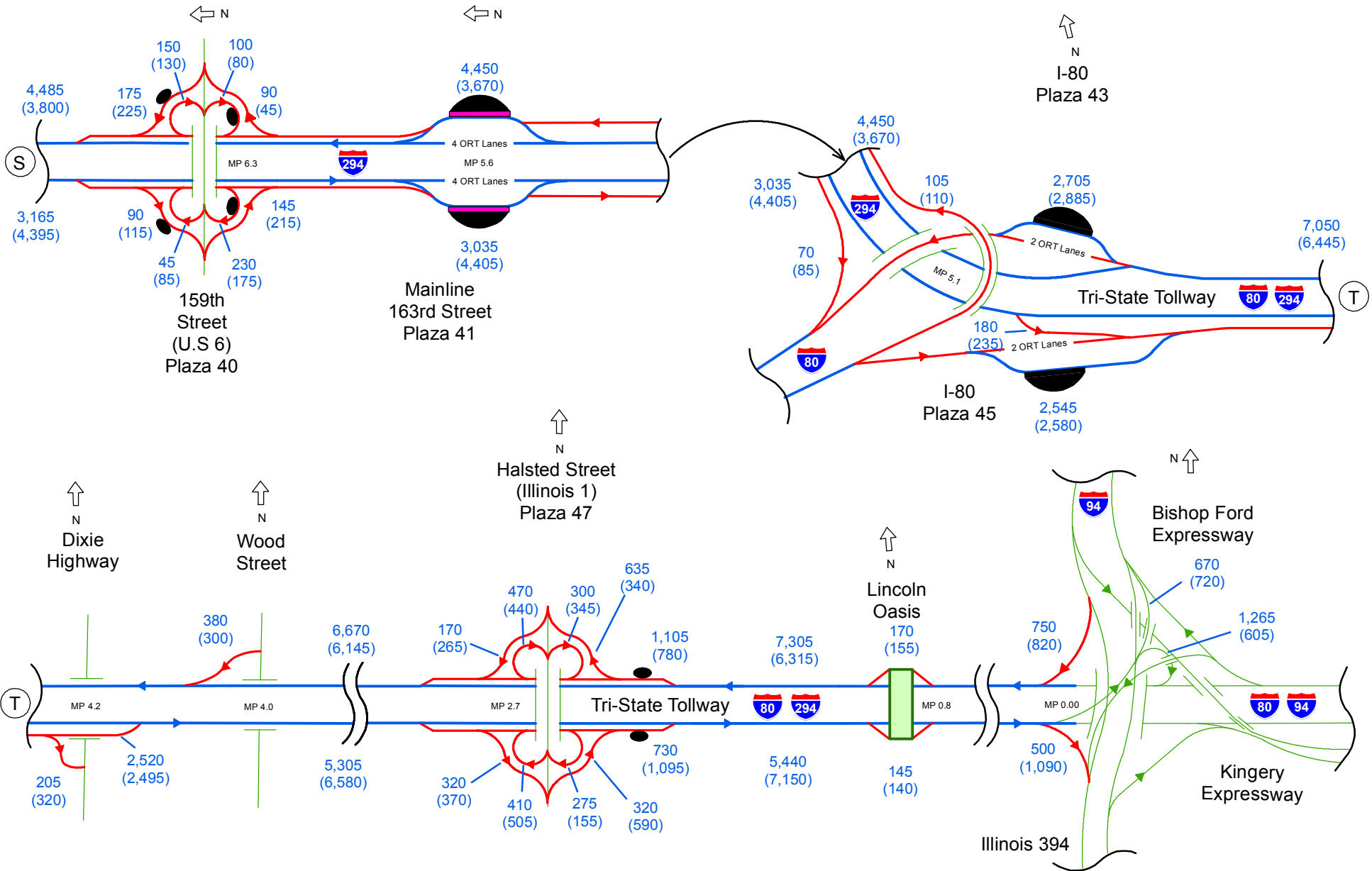

Note:
The 2016 AM & PM peak-hour volumes are defined as the 85th Percentile volumes occurring in the 6:00 to 8:00 AM and the 4:00 to 6:00 PM periods respectively. Peak-hour volumes are calculated from Monday through Thursday hourly traffic volume data only, and exclude holidays.

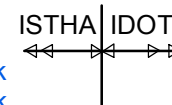



2016 A.M. & P.M. Peak Hour Traffic

On Reagan Memorial Tollway, from Illinois 26 to Orchard Road

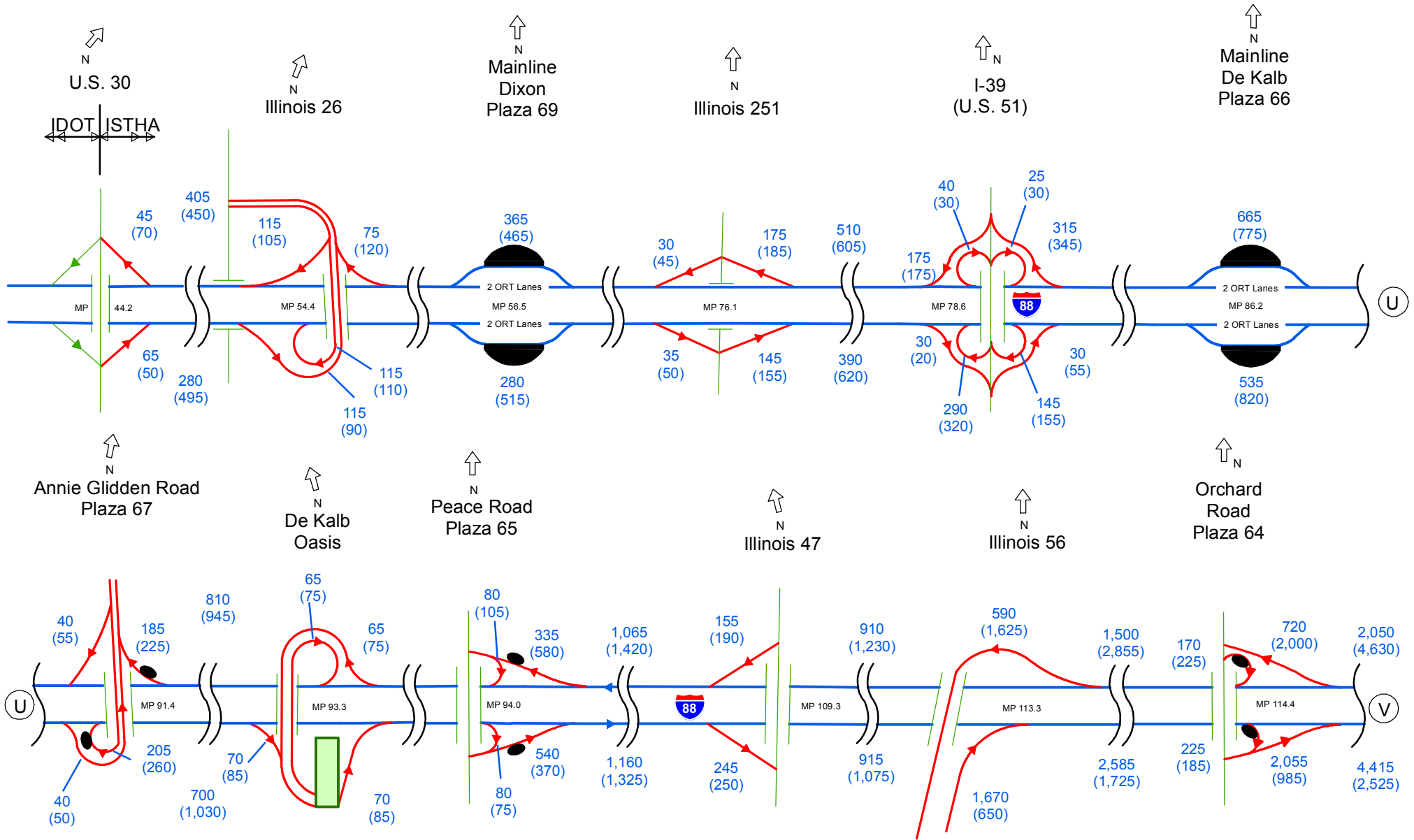

Note:
The 2016 AM & PM peak-hour volumes are defined as the 85th Percentile volumes occurring in the 6:00 to 8:00 AM and the 4:00 to 6:00 PM periods respectively. Peak-hour volumes are calculated from Monday through Thursday hourly traffic volume data only, and exclude holidays.



2016 A.M. & P.M. Peak Hour Traffic

On Reagan Memorial Tollway, from Illinois 31 to Illinois 53

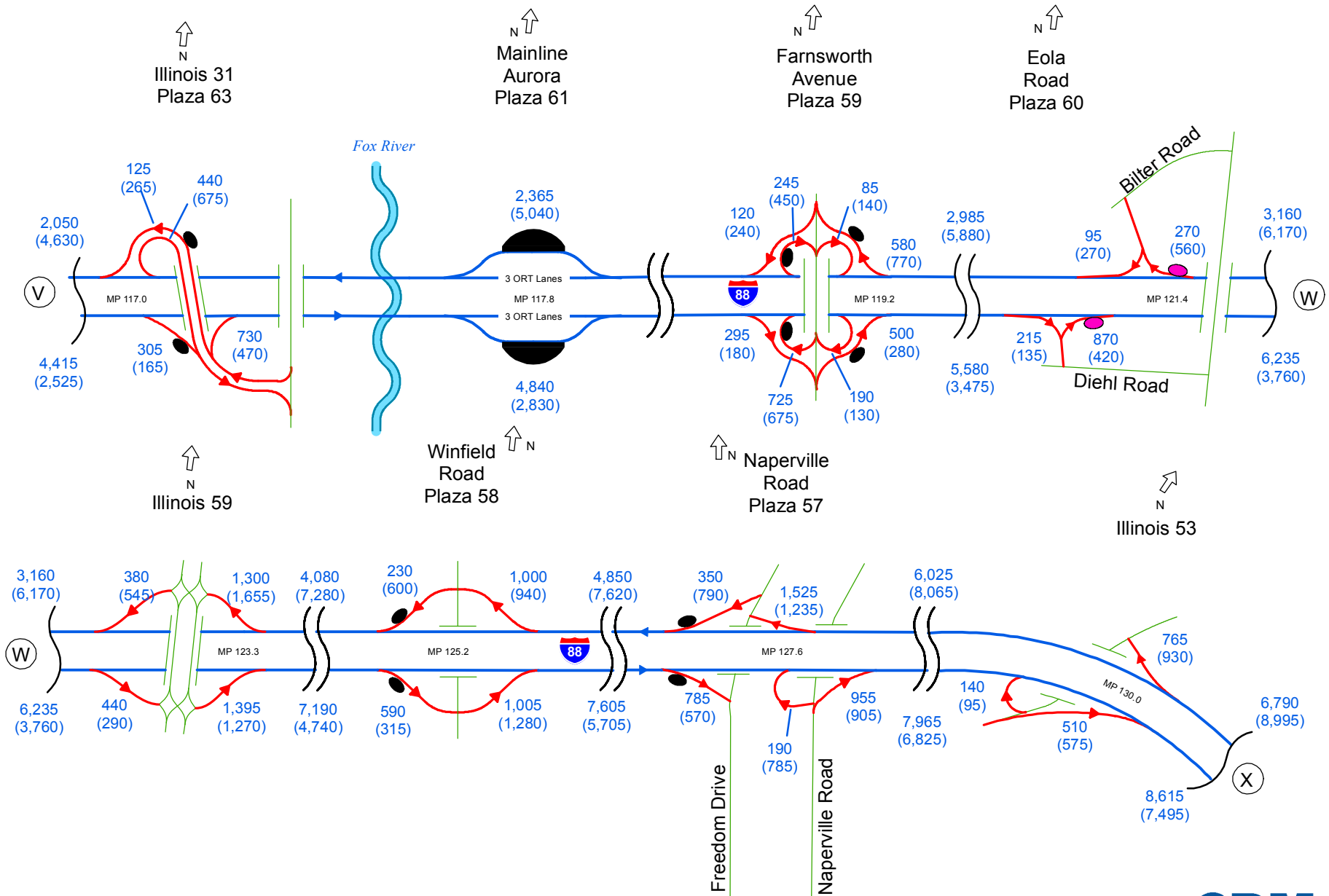

Note:
 The 2016 AM & PM peak-hour volumes are defined as the 85th Percentile volumes occurring in the 6:00 to 8:00 AM and the 4:00 to 6:00 PM periods respectively. Peak-hour volumes are calculated from Monday through Thursday hourly traffic volume data only, and exclude holidays.





2016 A.M. & P.M. Peak Hour Traffic

On Reagan Memorial Tollway, Veterans Memorial Tollway West Interchange

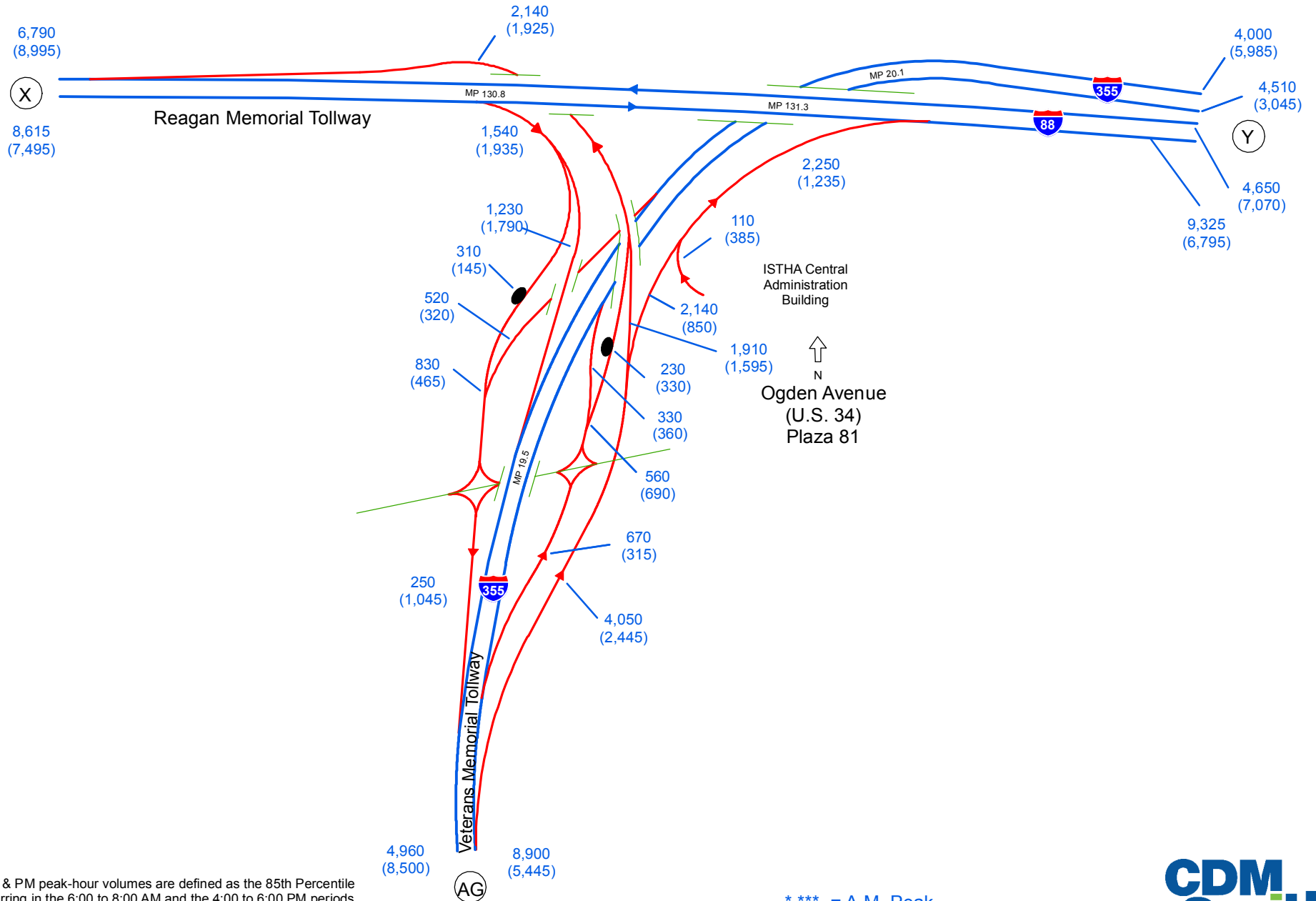

Note:
 The 2016 AM & PM peak-hour volumes are defined as the 85th Percentile volumes occurring in the 6:00 to 8:00 AM and the 4:00 to 6:00 PM periods respectively. Peak-hour volumes are calculated from Monday through Thursday hourly traffic volume data only, and exclude holidays.





2016 A.M. & P.M. Peak Hour Traffic

On Reagan Memorial Tollway, Veterans Memorial Tollway East Interchange

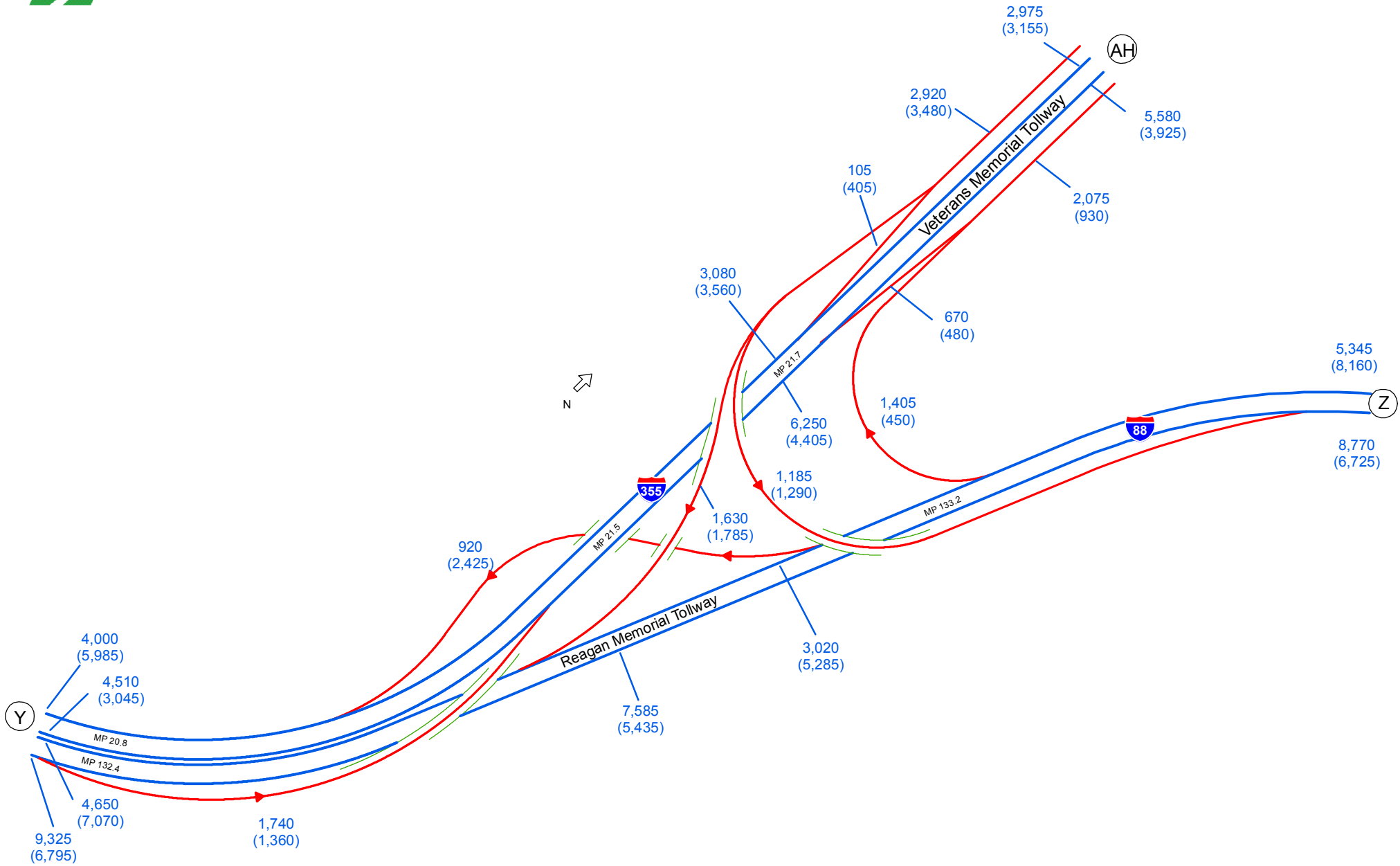

Note:
 The 2016 AM & PM peak-hour volumes are defined as the 85th Percentile volumes occurring in the 6:00 to 8:00 AM and the 4:00 to 6:00 PM periods respectively. Peak-hour volumes are calculated from Monday through Thursday hourly traffic volume data only, and exclude holidays.





2016 A.M. & P.M. Peak Hour Traffic

On Reagan Memorial Tollway, from Highland Avenue to Harger Road

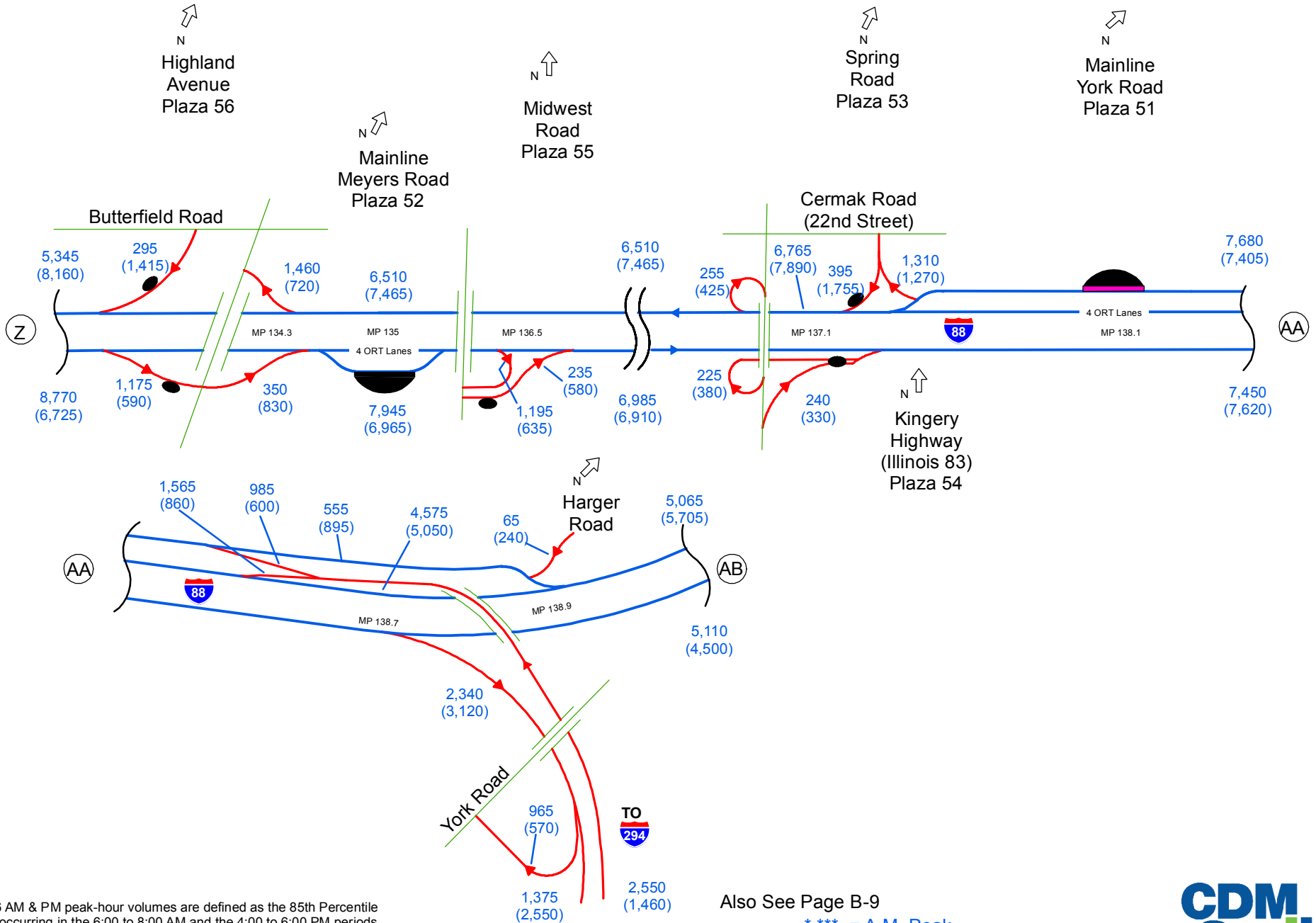

Note:
The 2016 AM & PM peak-hour volumes are defined as the 85th Percentile volumes occurring in the 6:00 to 8:00 AM and the 4:00 to 6:00 PM periods respectively. Peak-hour volumes are calculated from Monday through Thursday hourly traffic volume data only, and exclude holidays.

Also See Page B-9

*** = A.M. Peak
(*,***) = P.M. Peak





2016 A.M. & P.M. Peak Hour Traffic

On Reagan Memorial Tollway, from Roosevelt Road to Eisenhower Expressway (I-290)

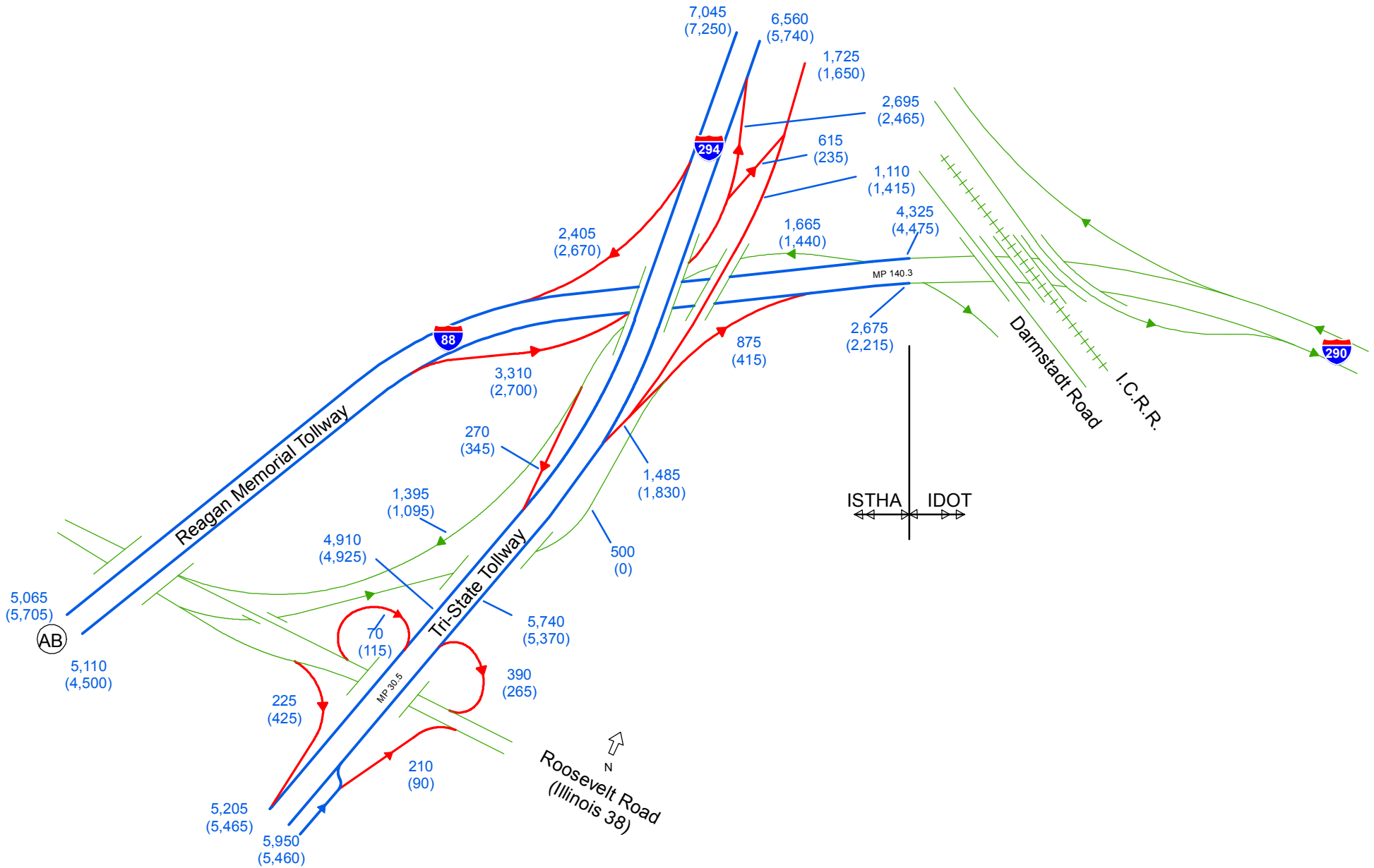

Note:
The 2016 AM & PM peak-hour volumes are defined as the 85th Percentile volumes occurring in the 6:00 to 8:00 AM and the 4:00 to 6:00 PM periods respectively. Peak-hour volumes are calculated from Monday through Thursday hourly traffic volume data only, and exclude holidays.





2016 A.M. & P.M. Peak Hour Traffic

On Veterans Memorial Tollway, from Interstate 80 to 127th Street

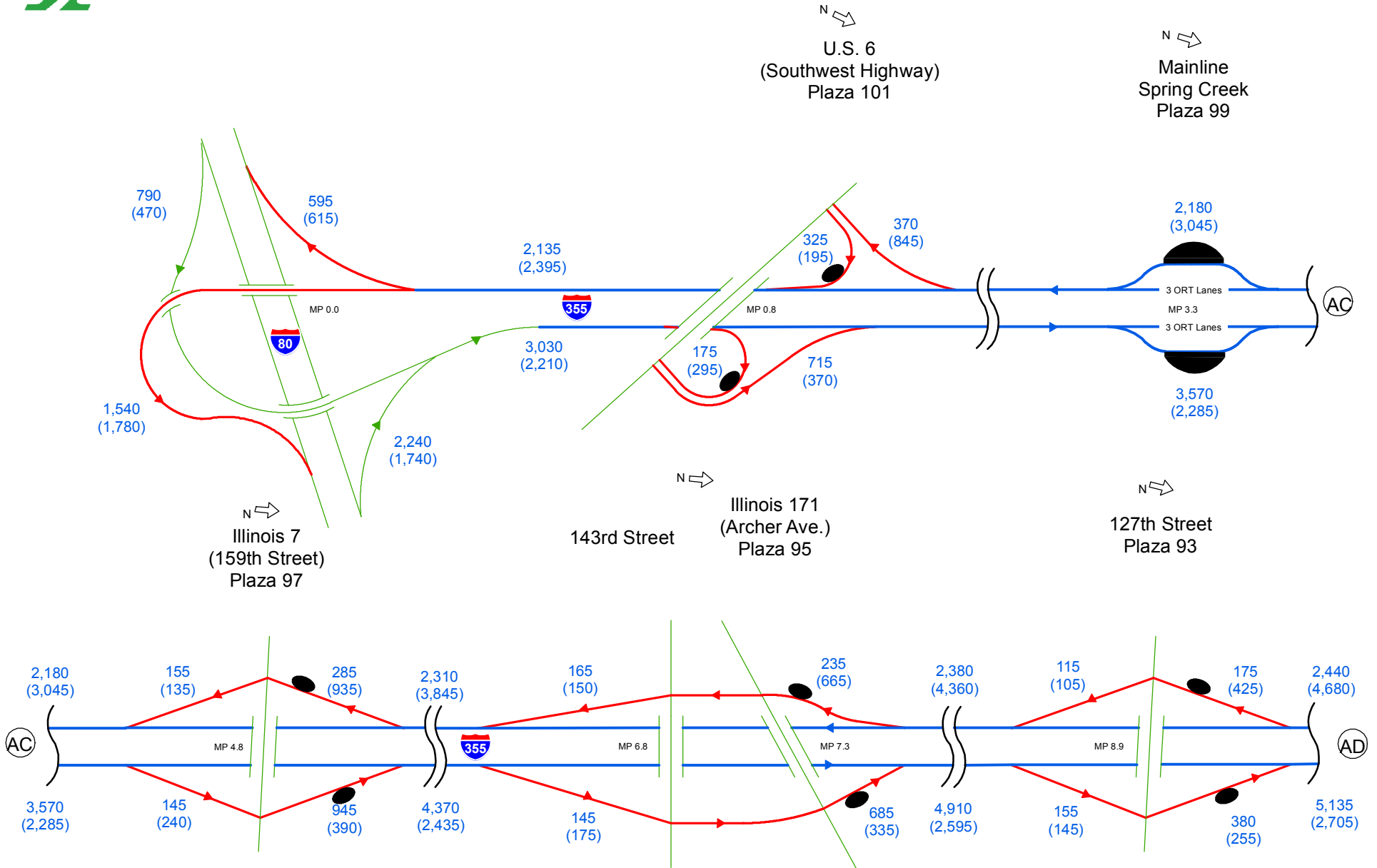

Note:
The 2016 AM & PM peak-hour volumes are defined as the 85th Percentile volumes occurring in the 6:00 to 8:00 AM and the 4:00 to 6:00 PM periods respectively. Peak-hour volumes are calculated from Monday through Thursday hourly traffic volume data only, and exclude holidays.



2016 A.M. & P.M. Peak Hour Traffic

On Veterans Memorial Tollway, At Interstate 55

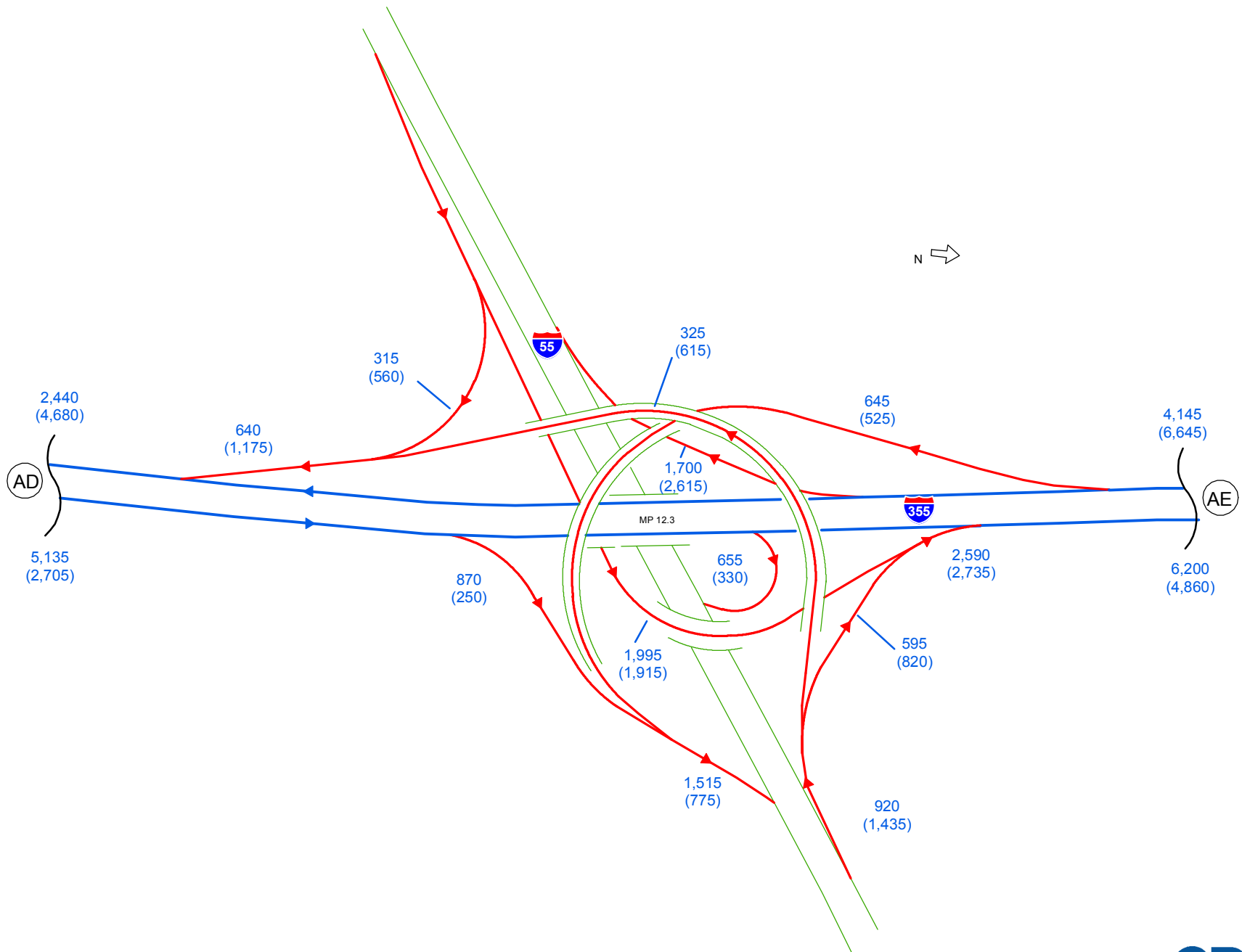

Note:
 The 2016 AM & PM peak-hour volumes are defined as the 85th Percentile volumes occurring in the 6:00 to 8:00 AM and the 4:00 to 6:00 PM periods respectively. Peak-hour volumes are calculated from Monday through Thursday hourly traffic volume data only, and exclude holidays.



2016 A.M. & P.M. Peak Hour Traffic

On Veterans Memorial Tollway, from Boughton Road to Maple Avenue

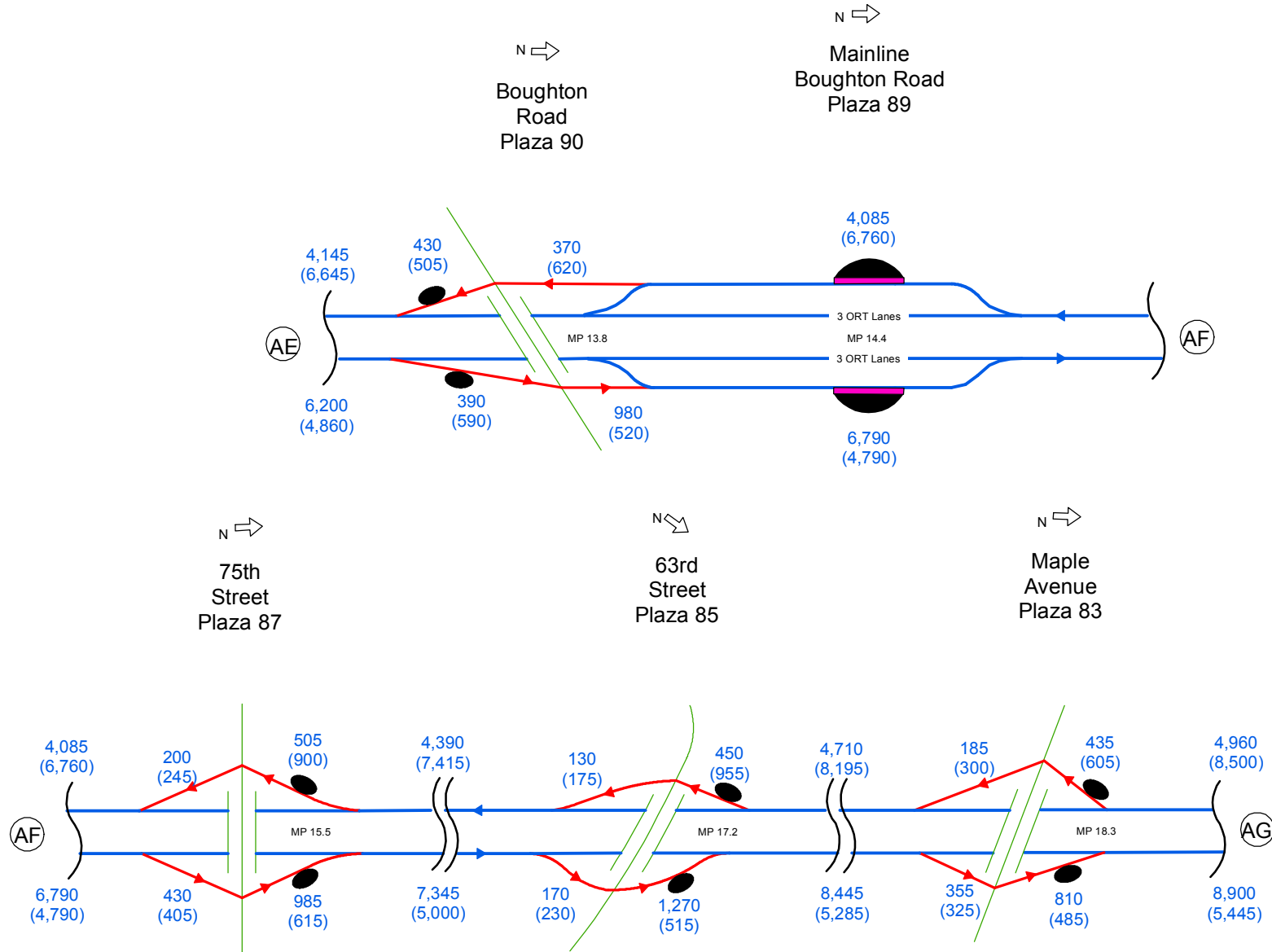

Note:
The 2016 AM & PM peak-hour volumes are defined as the 85th Percentile volumes occurring in the 6:00 to 8:00 AM and the 4:00 to 6:00 PM periods respectively. Peak-hour volumes are calculated from Monday through Thursday hourly traffic volume data only, and exclude holidays.



2016 A.M. & P.M. Peak Hour Traffic

On Veterans Memorial Tollway, from Ogden Avenue / West Interchange to Army Trail Road

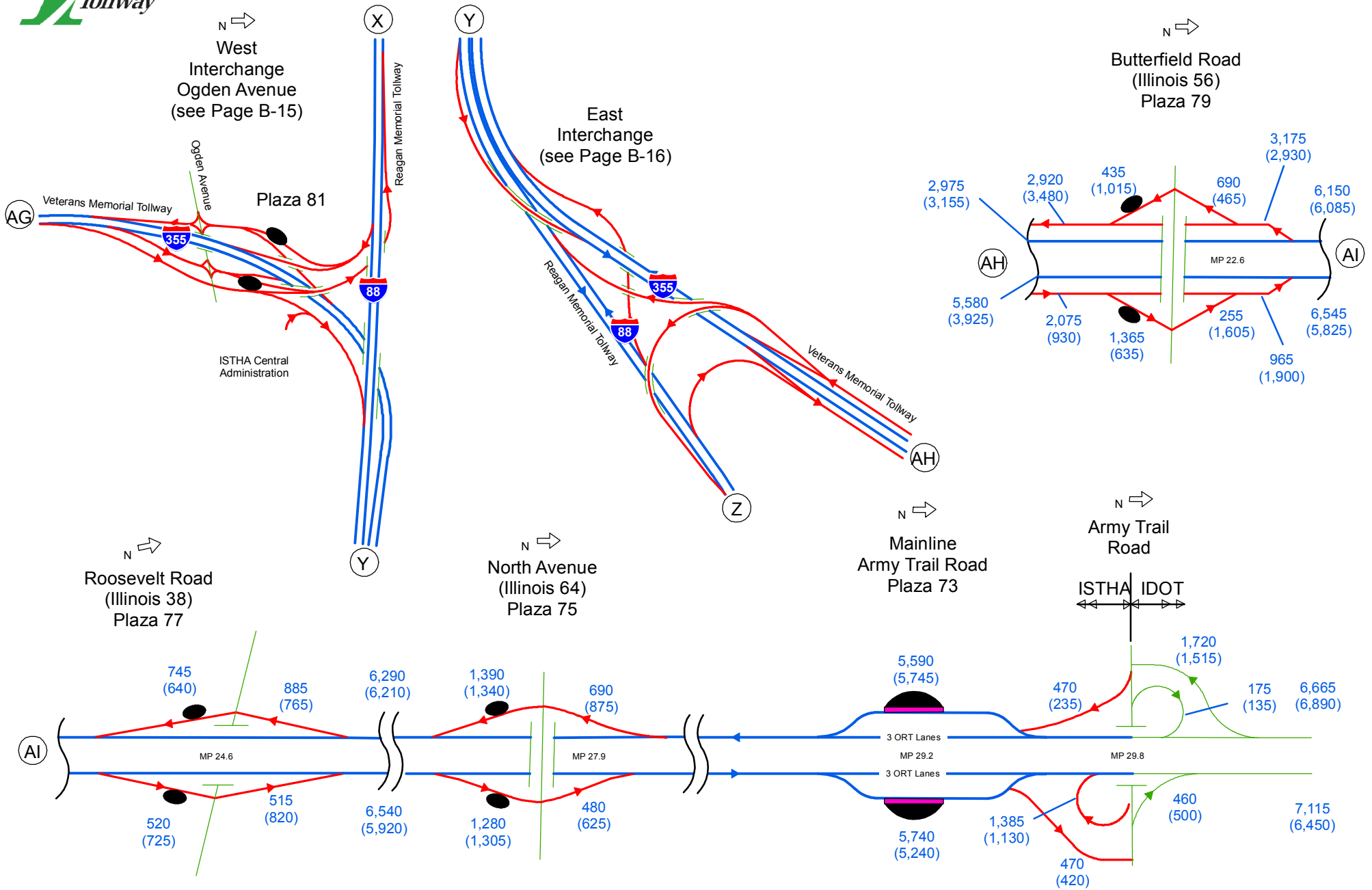

Note:
The 2016 AM & PM peak-hour volumes are defined as the 85th Percentile volumes occurring in the 6:00 to 8:00 AM and the 4:00 to 6:00 PM periods respectively. Peak-hour volumes are calculated from Monday through Thursday hourly traffic volume data only, and exclude holidays.



2016 A.M. & P.M. Peak Hour Traffic

On IL 390, from Lake Street to Plum Grove Road (Plaza 326)

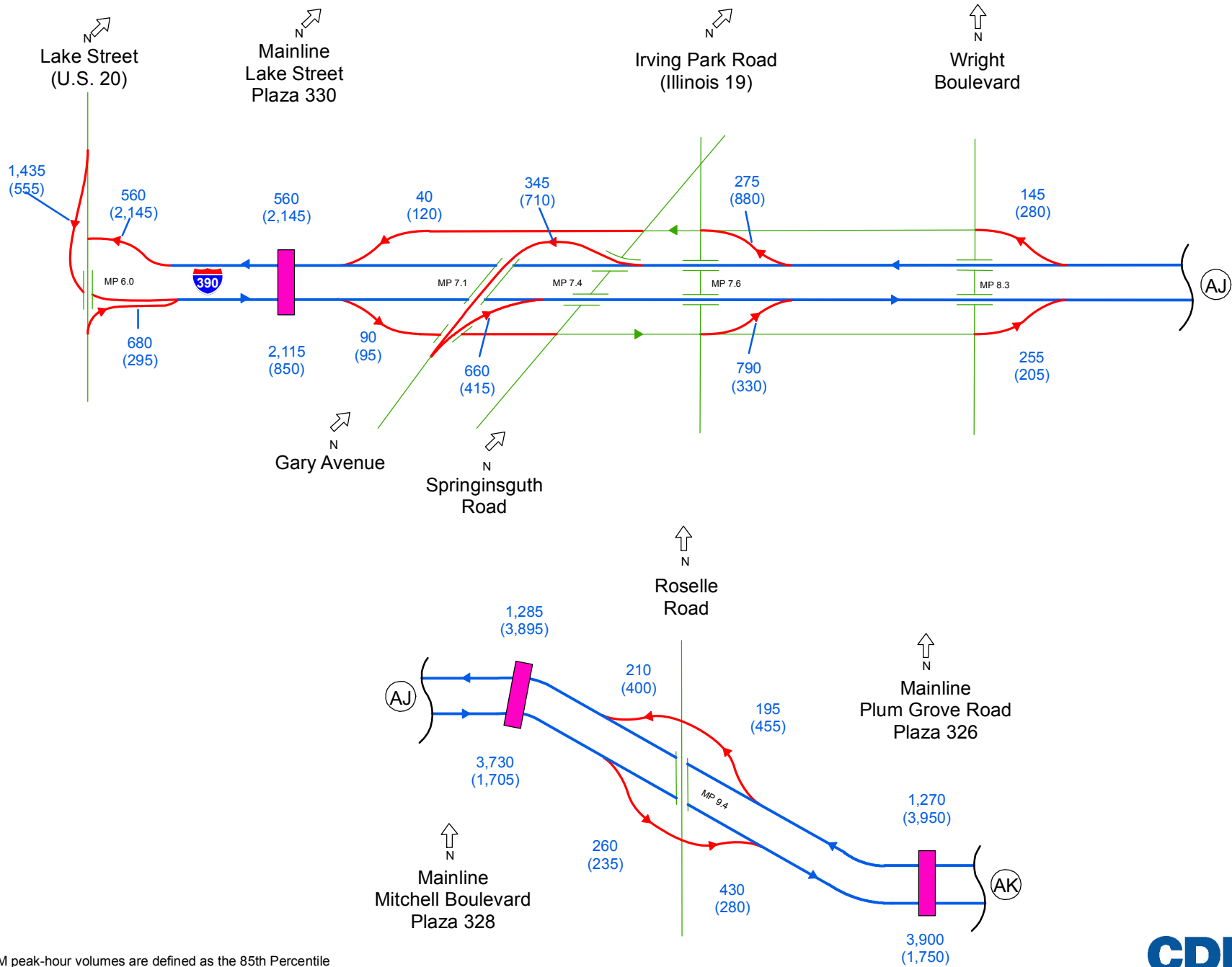

Note:
The 2016 AM & PM peak-hour volumes are defined as the 85th Percentile volumes occurring in the 6:00 to 8:00 AM and the 4:00 to 6:00 PM periods respectively. Peak-hour volumes are calculated from Monday through Thursday hourly traffic volume data only, and exclude holidays.



2016 A.M. & P.M. Peak Hour Traffic

On IL 390, from Plum Grove Road (Plaza 326) to Interstate 290

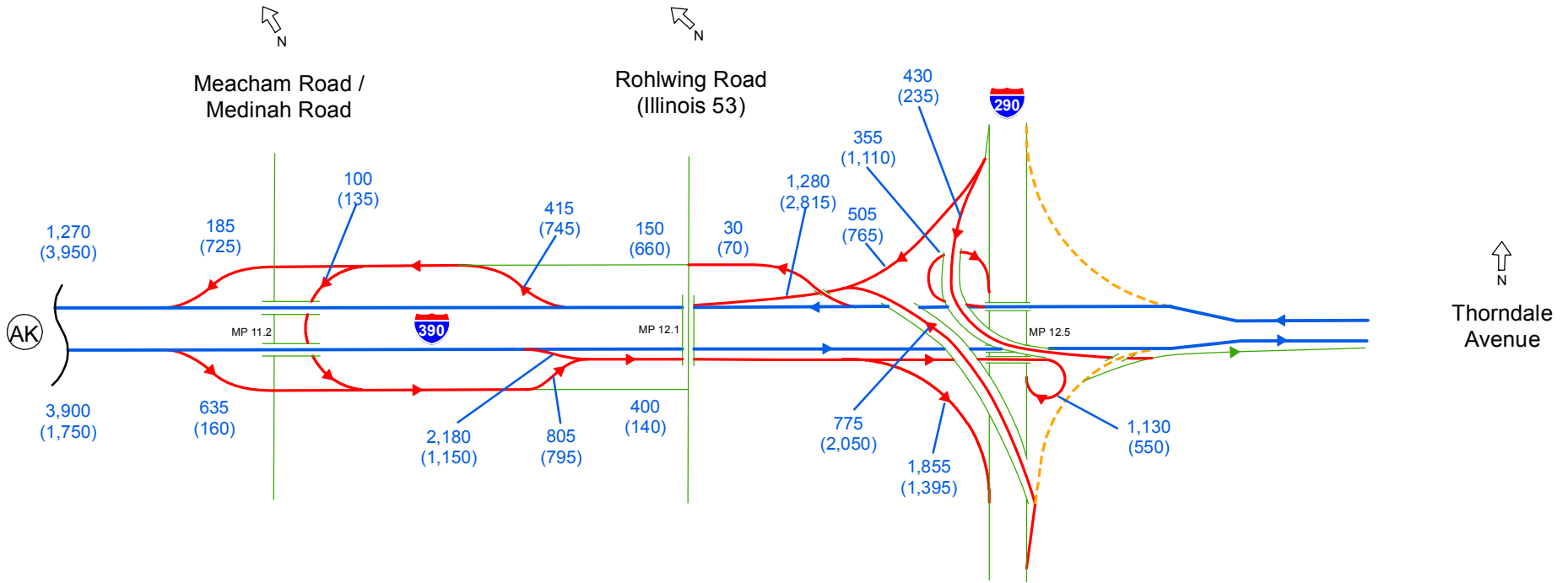

Note:
 The 2016 AM & PM peak-hour volumes are defined as the 85th Percentile volumes occurring in the 6:00 to 8:00 AM and the 4:00 to 6:00 PM periods respectively. Peak-hour volumes are calculated from Monday through Thursday hourly traffic volume data only, and exclude holidays.





APPENDIX C

2016 LANE CONFIGURATION SCHEMATICS



2016 CONSTRUCTION PROJECTS

Page #	Facility	Description	Milepost		Construction Schedule	
			Start	End	Start	End
Illinois Tollway						
C-2 to C-4	I-90	Rebuilding/Widening Elgin Toll Plaza to Tri-State Tollway	53.8	77.8	2014	2016
C-1	I-90	Bridge Reconstruction Tripp Road and Spring Center Road	24.6		03/2016	2016
C-2	I-90	Ramp Rehabilitation U.S. Route 20	42.3		Spring 2016	Summer 2016
C-2	I-90	Bridge Reconstruction Higgins Road (Illinois Route 72) in Gilberts	49.5		04/2015	2016
C-2	I-90	Ramp Rehabilitation Randall Road	53.3		05/2016	Summer 2016
C-2	I-90	Interchange Reconstruction Illinois Route 31	54.6		03/2015	12/2016
C-2	I-90	Bridge Reconstruction Fox River Bridge	55.6		2014	2016
C-2	I-90	Interchange Reconstruction Illinois Route 25	56.3		04/2014	12/2016
C-2	I-90	Bridge Reconstruction Higgins Road (Illinois Route 72)	61.3		Summer 2014	06/2016
C-2	I-90	Interchange Reconstruction Barrington Road	62.2		Summer 2015	Summer 2017
C-3	I-90	Interchange Reconstruction Roselle Road	65.5		Spring 2014	2017
C-3	I-90	New Interchange Construction Meacham Road	67.3		Spring 2014	11/2016
C-3	I-90	Interchange Construction Elmhurst Road	73.5		Summer 2014	2017
C-13	I-88	Roadway Resurfacing U.S. Route 30 to U.S. Route 52	44.2	55.1	2016	Spring 2017
C-13	I-88	Overhead Bridge Repairs between Illinois Route 251 and U.S. Route 52	46.3	64.6	03/2016	12/2016
C-13	I-88	Roadway Resurfacing U.S. Route 52 to Illinois Route 251	55.1	76.1	2015	Spring 2016
C-14	I-88	Bridge Reconstruction & Interchange Improvements Farnsworth Avenue	119.2		May 2016	2017



2016 CONSTRUCTION PROJECTS

Page #	Facility	Description	Milepost		Construction Schedule	
			Start	End	Start	End
Illinois Tollway						
C-21	I-355	Roadway Widening & Ramp Reconstruction SB I-355 between 71st Street and south of 75th Street	15.0	16.0	06/2016	12/2016
C-23 to C-24	IL 390	New Illinois Route 390 Construction Lake Street (U.S. Route 20) to Meacham Road	6.0	12.6	Fall 2013	July 2016
C-24	IL 390	Interchange Reconstruction I-290 at Illinois Route 390	12.5		Summer 2014	End 2017
C-24	IL 390	New Illinois Route 390 Construction I-290 to Illinois Route 83	12.6		2014	2017
IDOT Expressway System						
N/A	I-90	Add Lane and Cumberland Flyover I-190 to Harlem Avenue			10/2016	11/2018
N/A	I-90/94	Jane Byrne Interchange Project I-90/94 at I-290			2015	Summer 2017
N/A	I-55	Interchange Reconstruction U.S. Route 41 (Lake Shore Drive)			05/2015	07/2017
N/A	IL 171	Bridge Reconstruction Illinois Route 171 at I-55			Winter 2014	Fall 2016



2016 Lane Configuration

On Jane Addams Memorial Tollway, from Rockton Road to Marengo (Plaza 7)

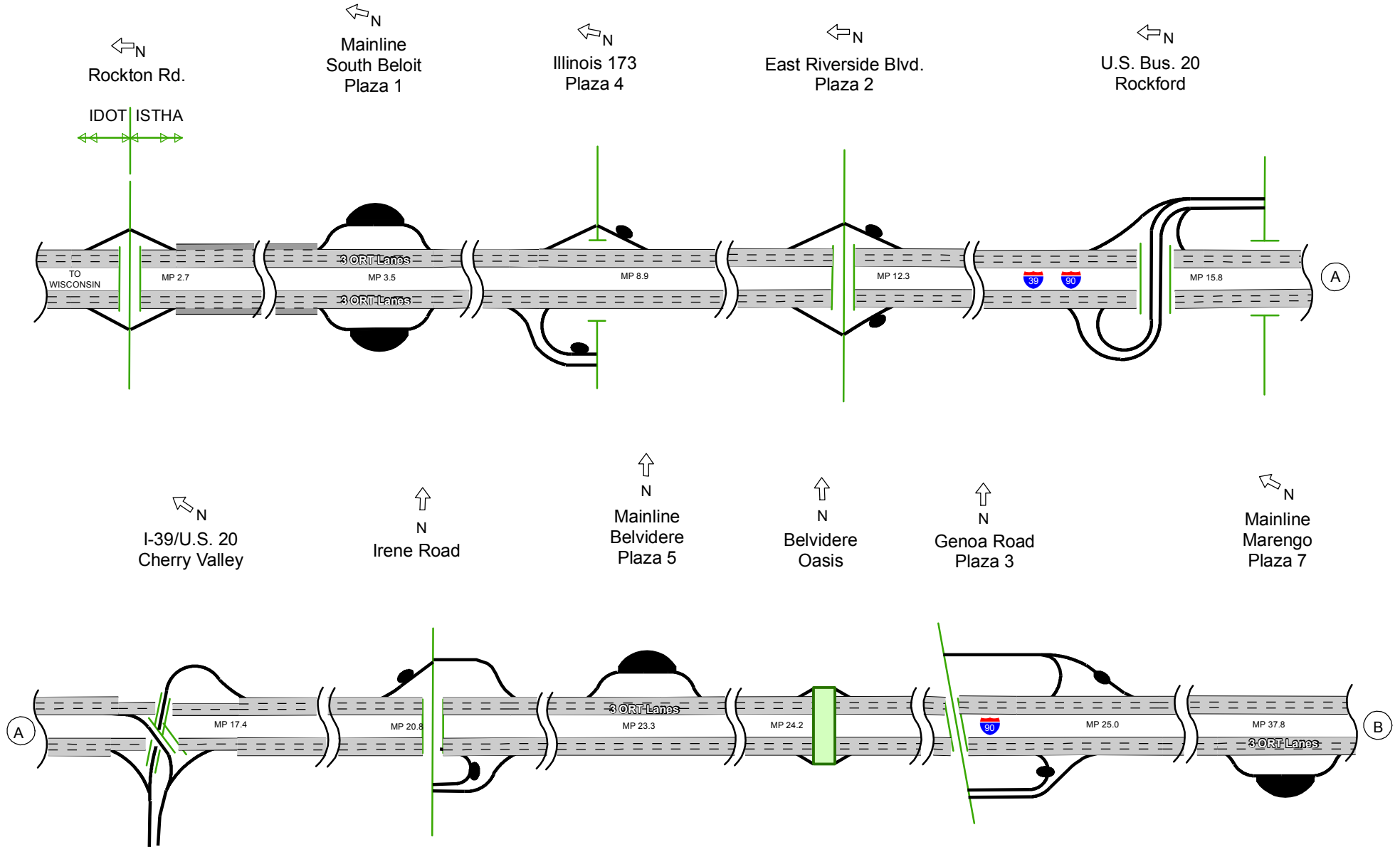

- Rehabilitation Project
- Off-System Rehabilitation
- Construction Project
- Off-System Construction





2016 Lane Configuration

On Jane Addams Memorial Tollway, from U.S. 20, Marengo to Barrington Road

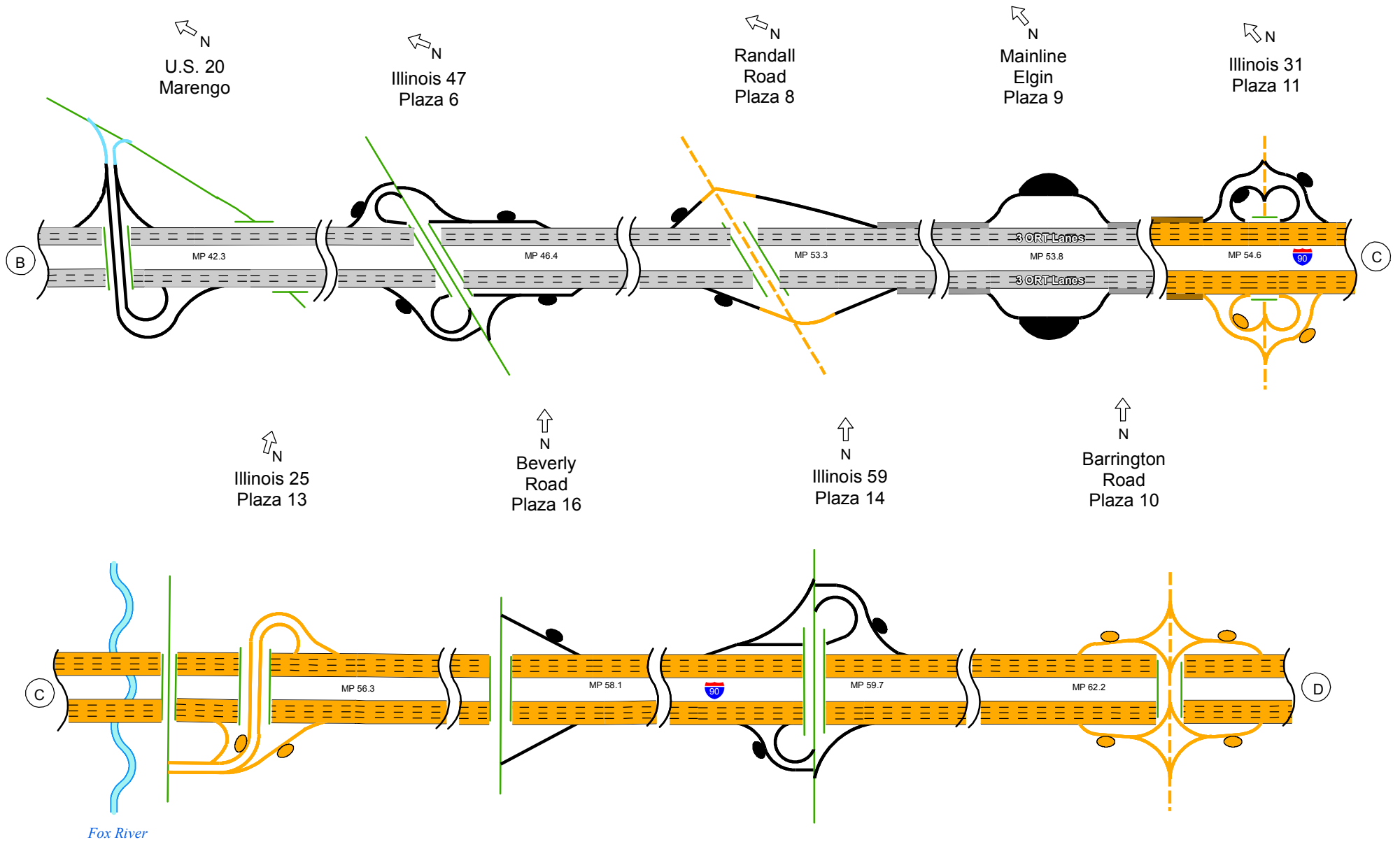



2016 Lane Configuration

On Jane Addams Memorial Tollway, from Roselle Road to Devon Avenue

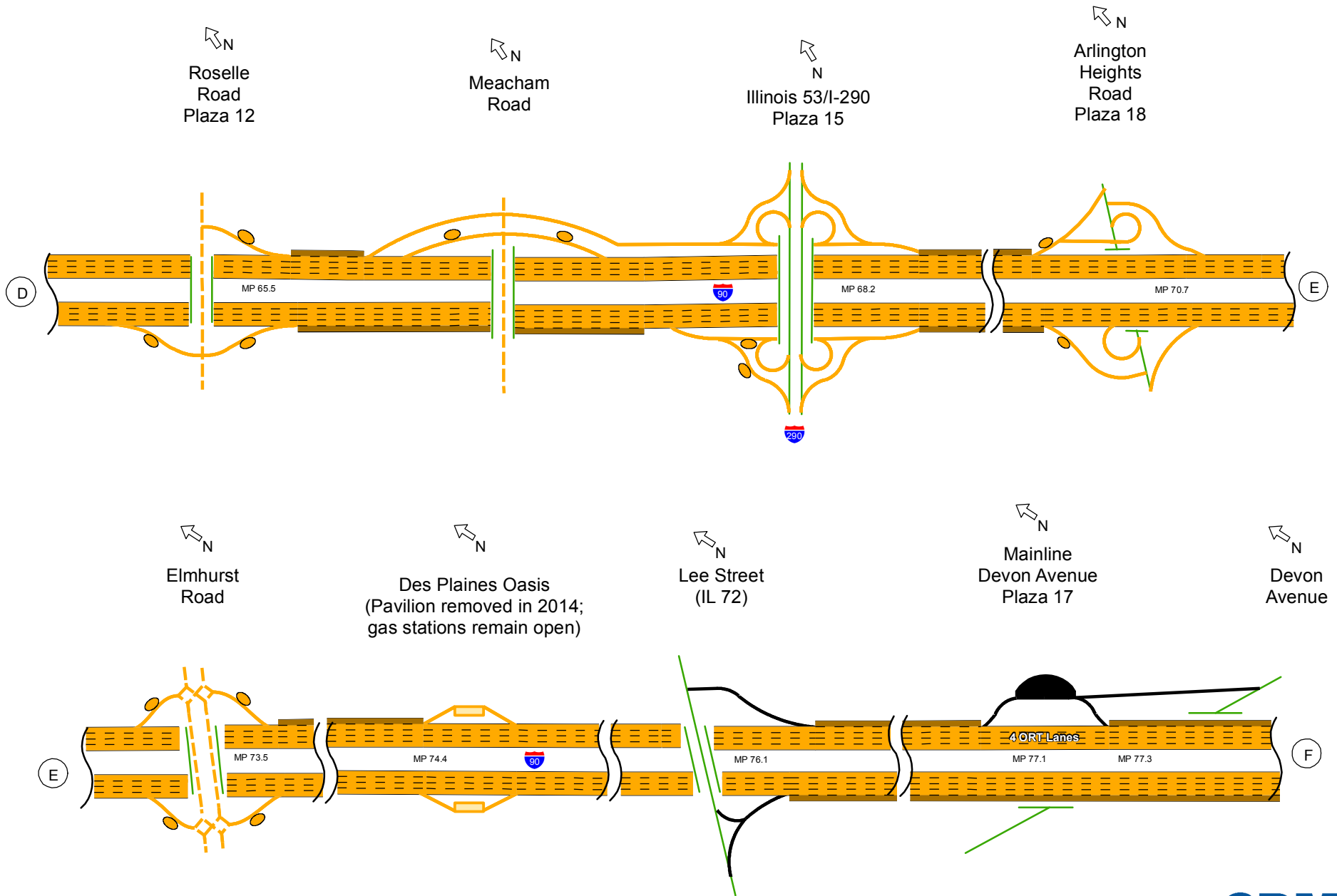

-  Rehabilitation Project
-  Construction Project
-  Off-System Rehabilitation
-  Off-System Construction





2016 Lane Configuration

On Jane Addams Memorial Tollway, from Tri-State Tollway to Kennedy Expressway

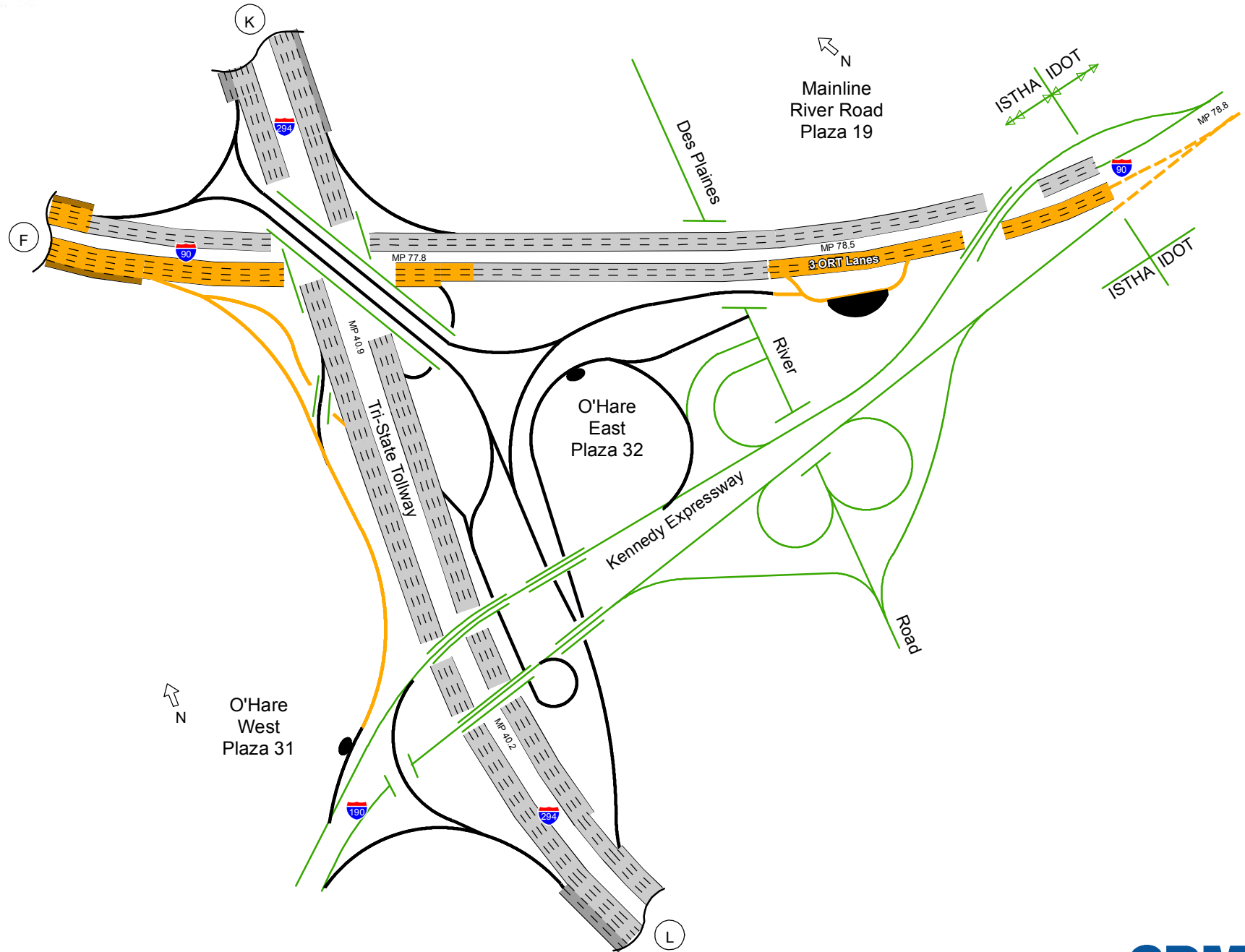

- Rehabilitation Project
- Off-System Rehabilitation
- Construction Project
- Off-System Construction





2016 Lane Configuration

On Tri-State Tollway, from Russell Road to Lake Forest Oasis

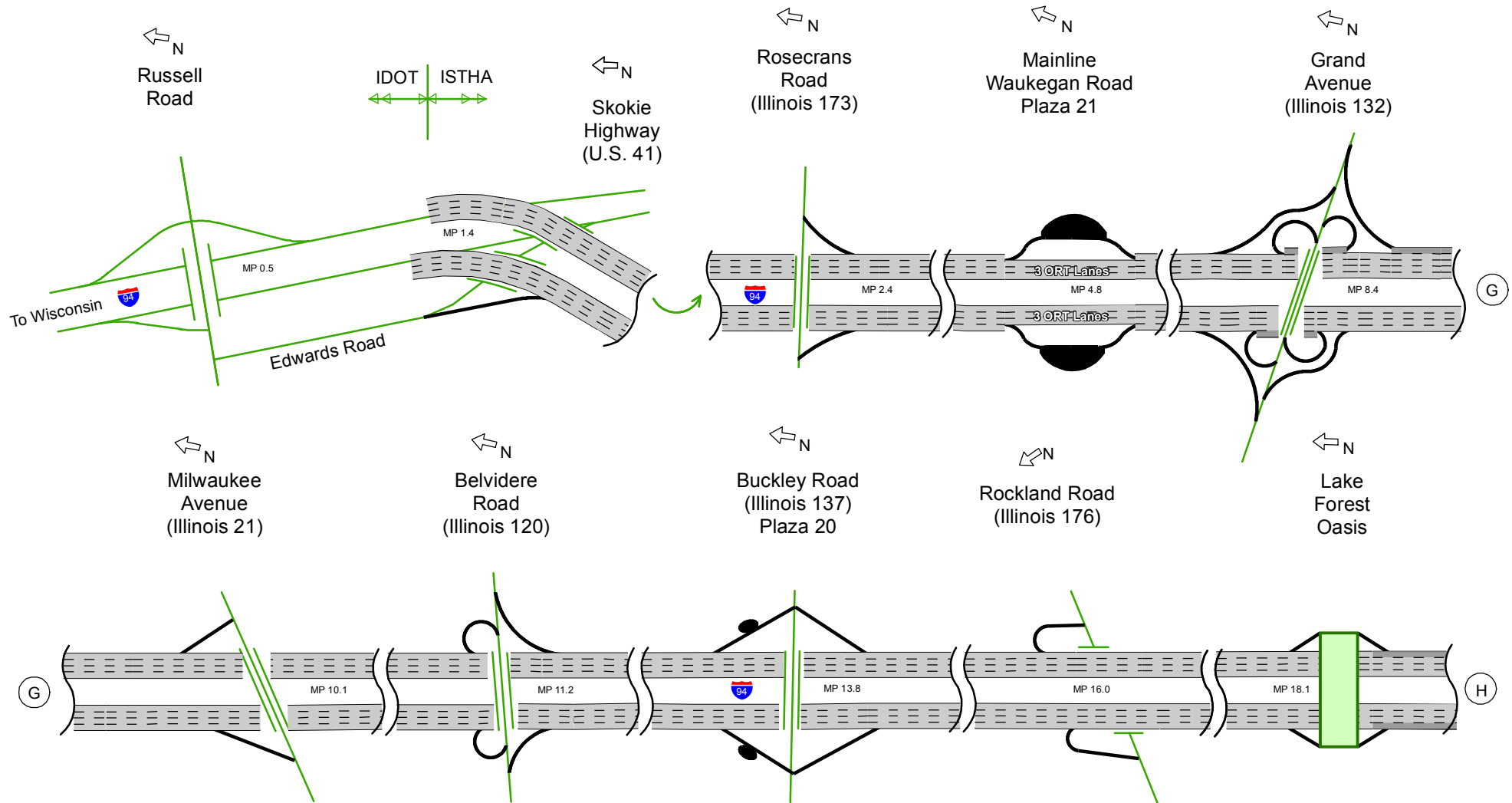

- Rehabilitation Project
- Off-System Rehabilitation
- Construction Project
- Off-System Construction





2016 Lane Configuration

On Tri-State Tollway, from Town Line Road (Illinois 60) to Golf Road (Illinois 58) and Edens Spur

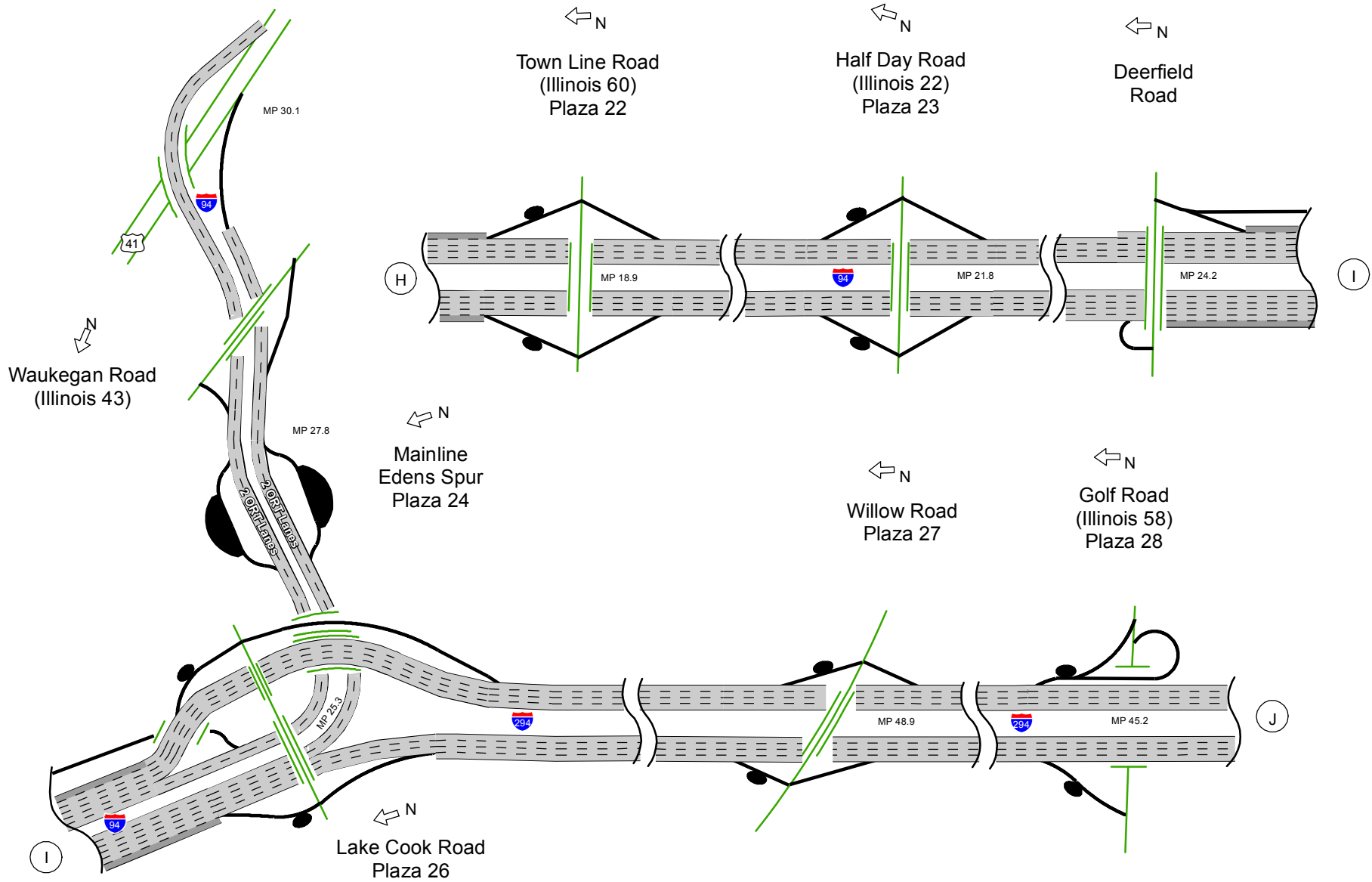

-  Rehabilitation Project
-  Off-System Rehabilitation
-  Construction Project
-  Off-System Construction





2016 Lane Configuration

On Tri-State Tollway, from Dempster Street to O'Hare Oasis

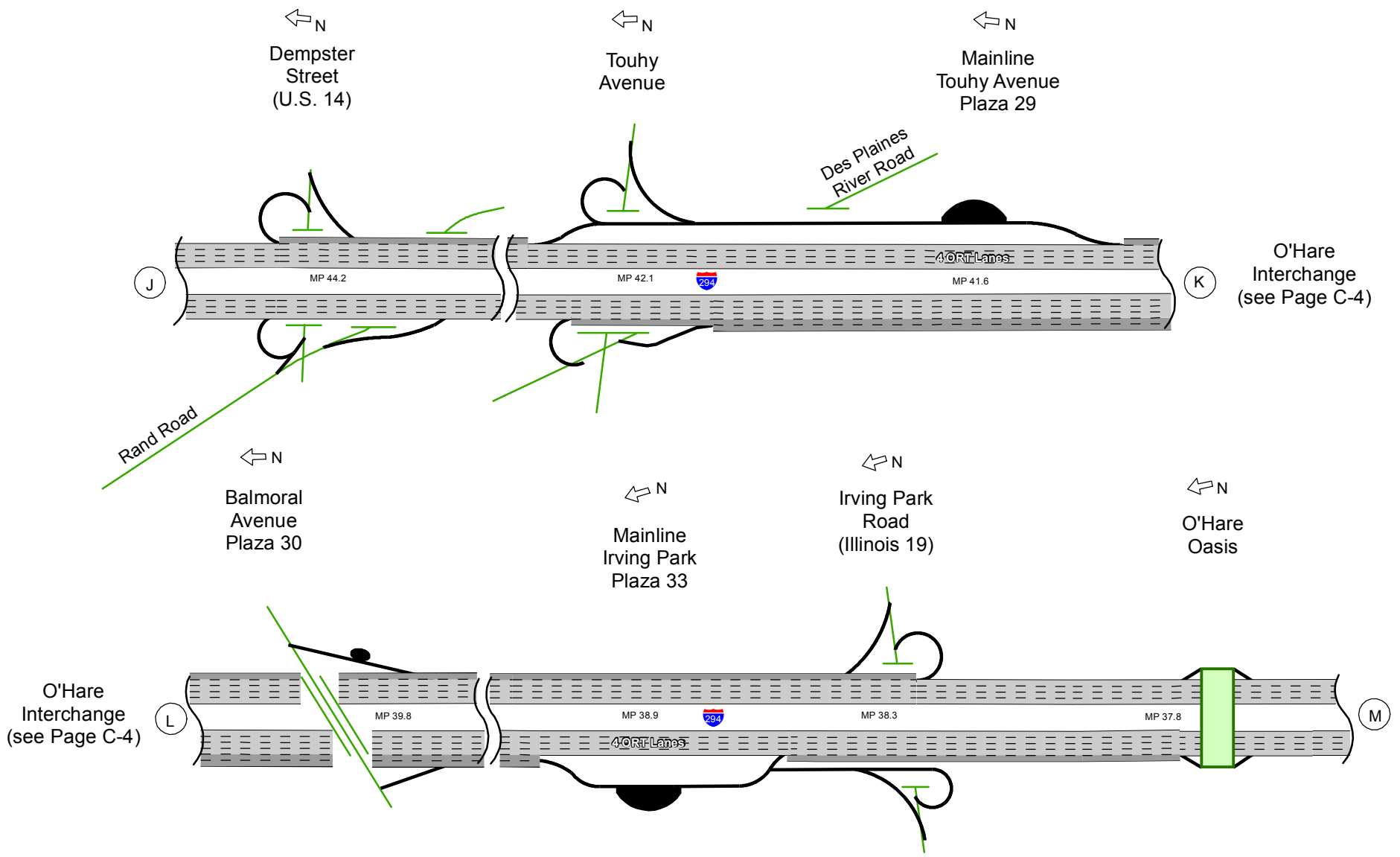

- Rehabilitation Project
- Construction Project
- Off-System Rehabilitation
- Off-System Construction





2016 Lane Configuration

On Tri-State Tollway, from North Avenue / Lake Street to Reagan Memorial Tollway (I-88)

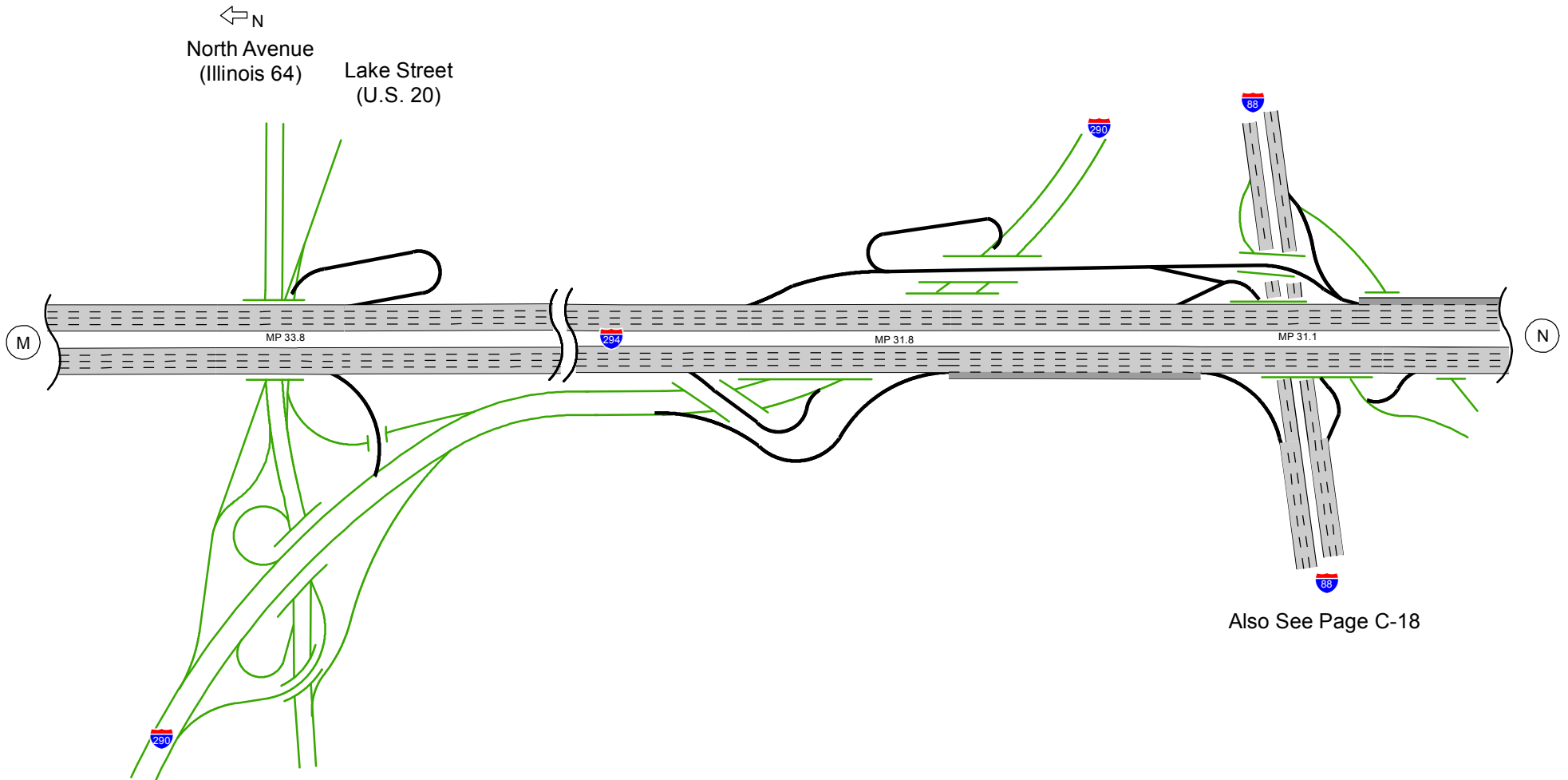

Also See Page C-18

- Rehabilitation Project
- Construction Project
- Off-System Rehabilitation
- Off-System Construction





2016 Lane Configuration

On Tri-State Tollway, from Roosevelt Road to Hinsdale Oasis

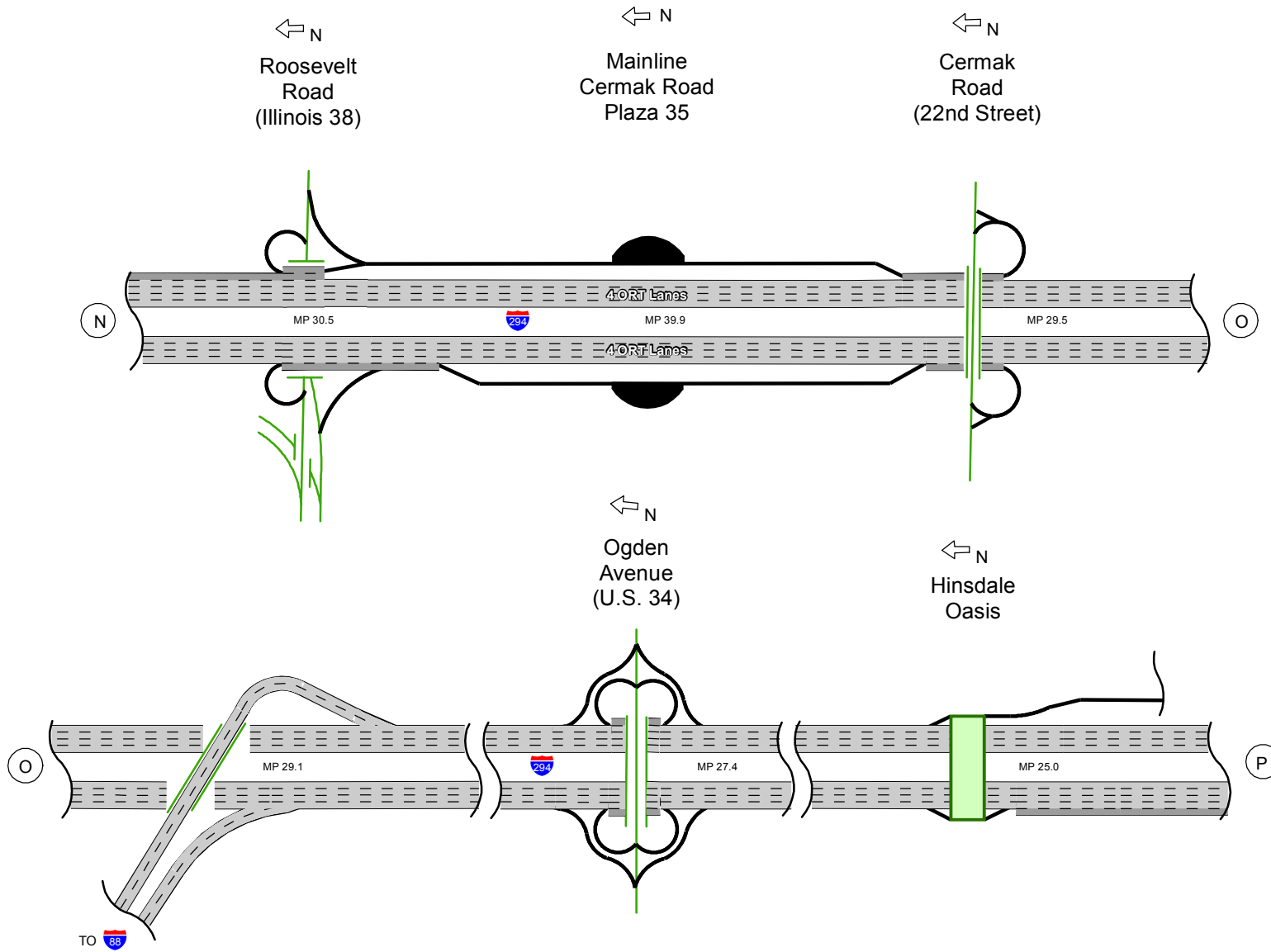

Also See Page C-17

- Rehabilitation Project
- Construction Project
- Off-System Rehabilitation
- Off-System Construction





2016 Lane Configuration

On Tri-State Tollway, from Joliet Road (Plaza 37) to Willow Springs Road (Plaza 34)

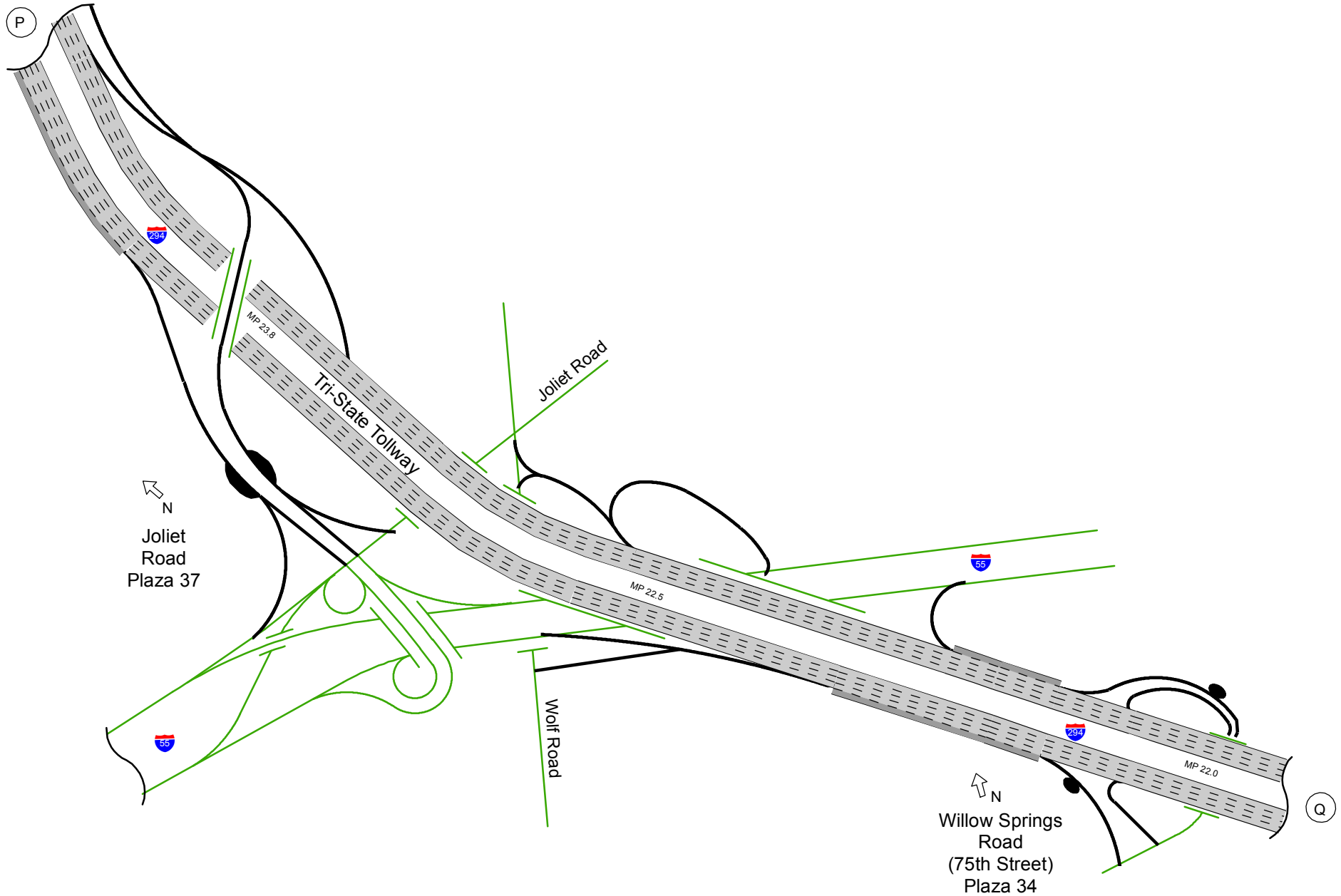

- Rehabilitation Project
- Off-System Rehabilitation
- Construction Project
- Off-System Construction





2016 Lane Configuration

On Tri-State Tollway, from Archer / Lagrange / 79th Street to 147th Street (Plaza 42) / I-57

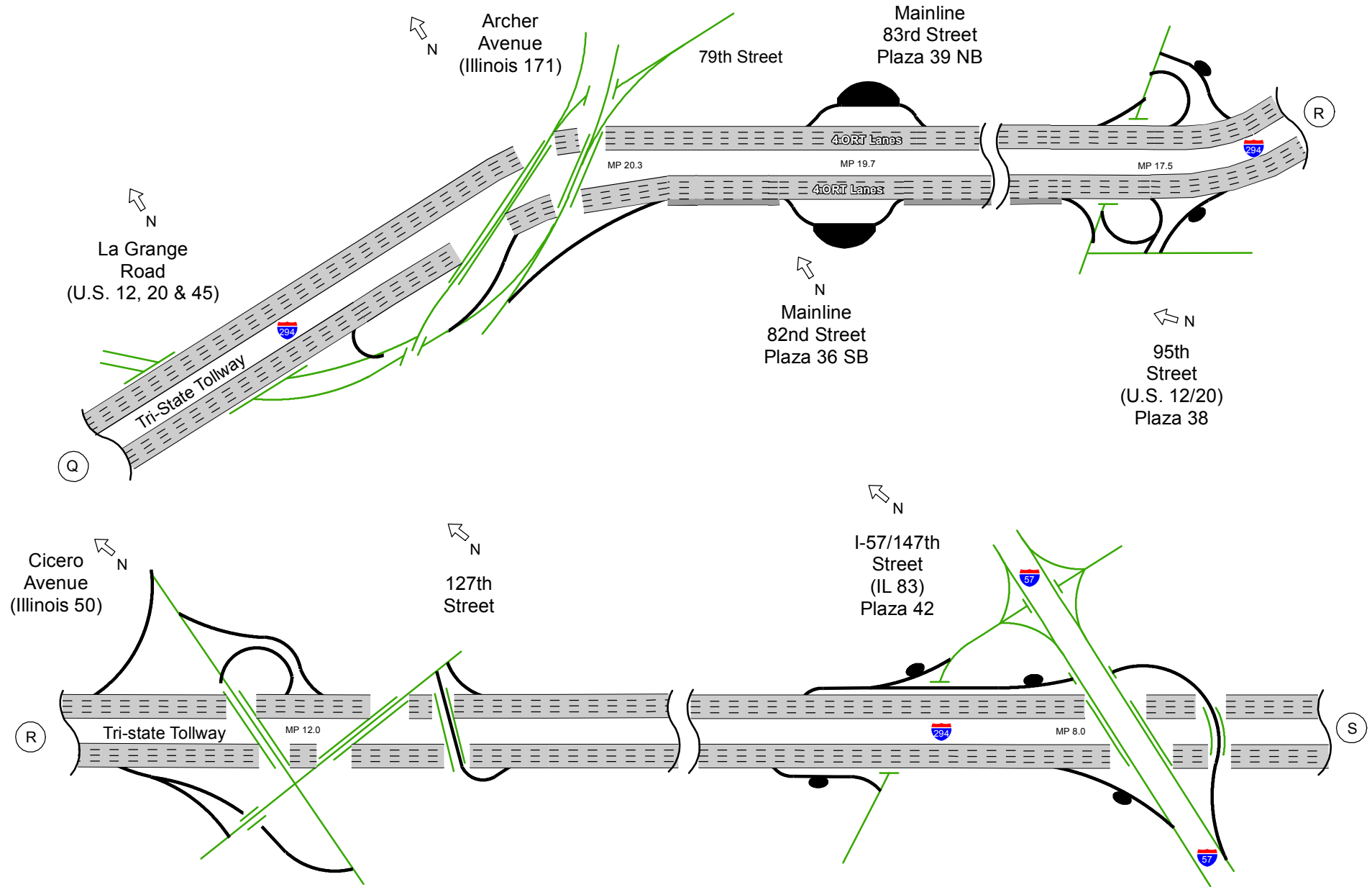

- Rehabilitation Project
- Construction Project
- Off-System Rehabilitation
- Off-System Construction





2016 Lane Configuration

On Tri-State Tollway, from 159th Street (Plaza 40) to Bishop Ford / Kingery Expressway

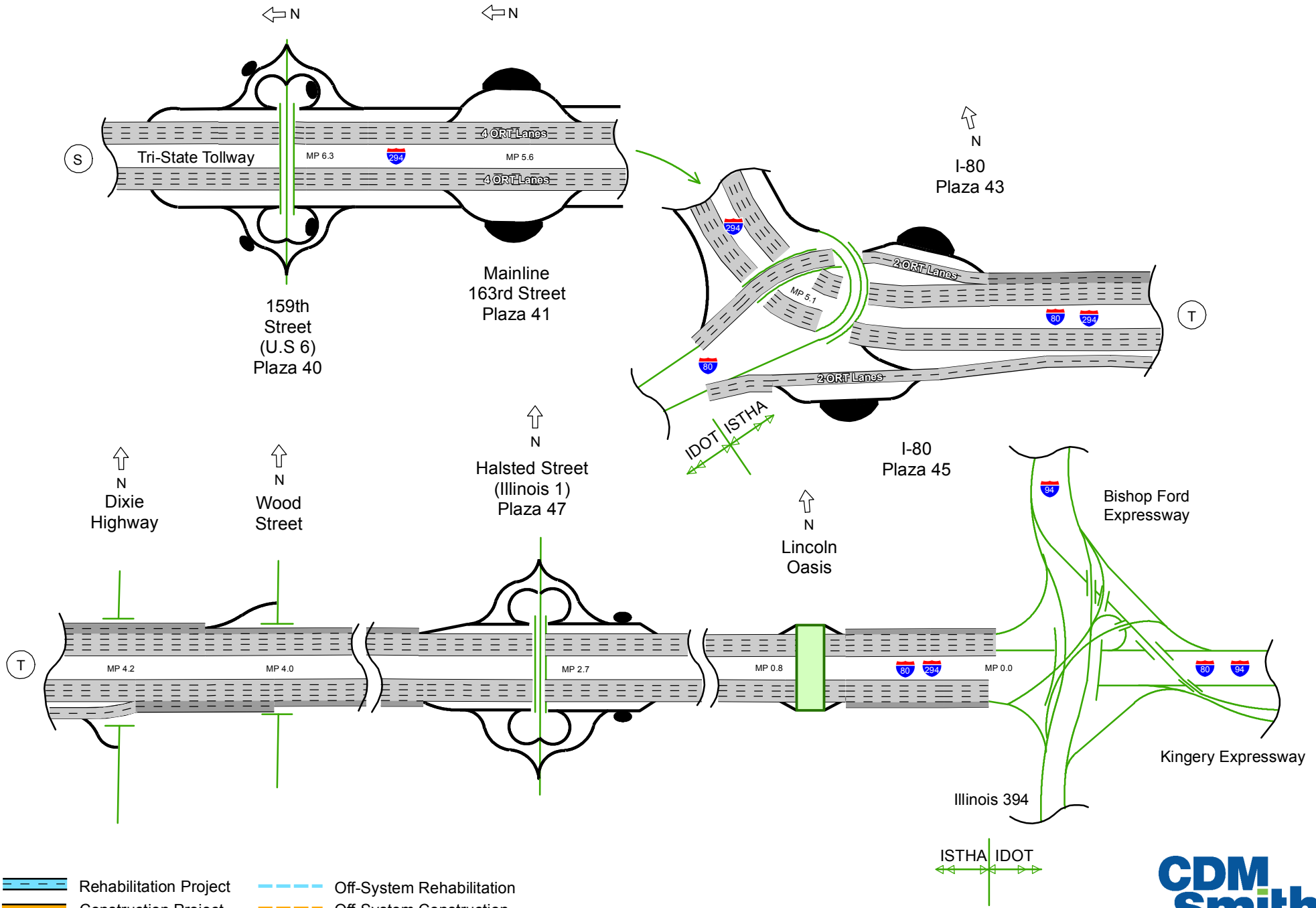

- Rehabilitation Project
- Construction Project
- Off-System Rehabilitation
- Off-System Construction





2016 Lane Configuration

On Reagan Memorial Tollway, from Illinois 26 to Orchard Road

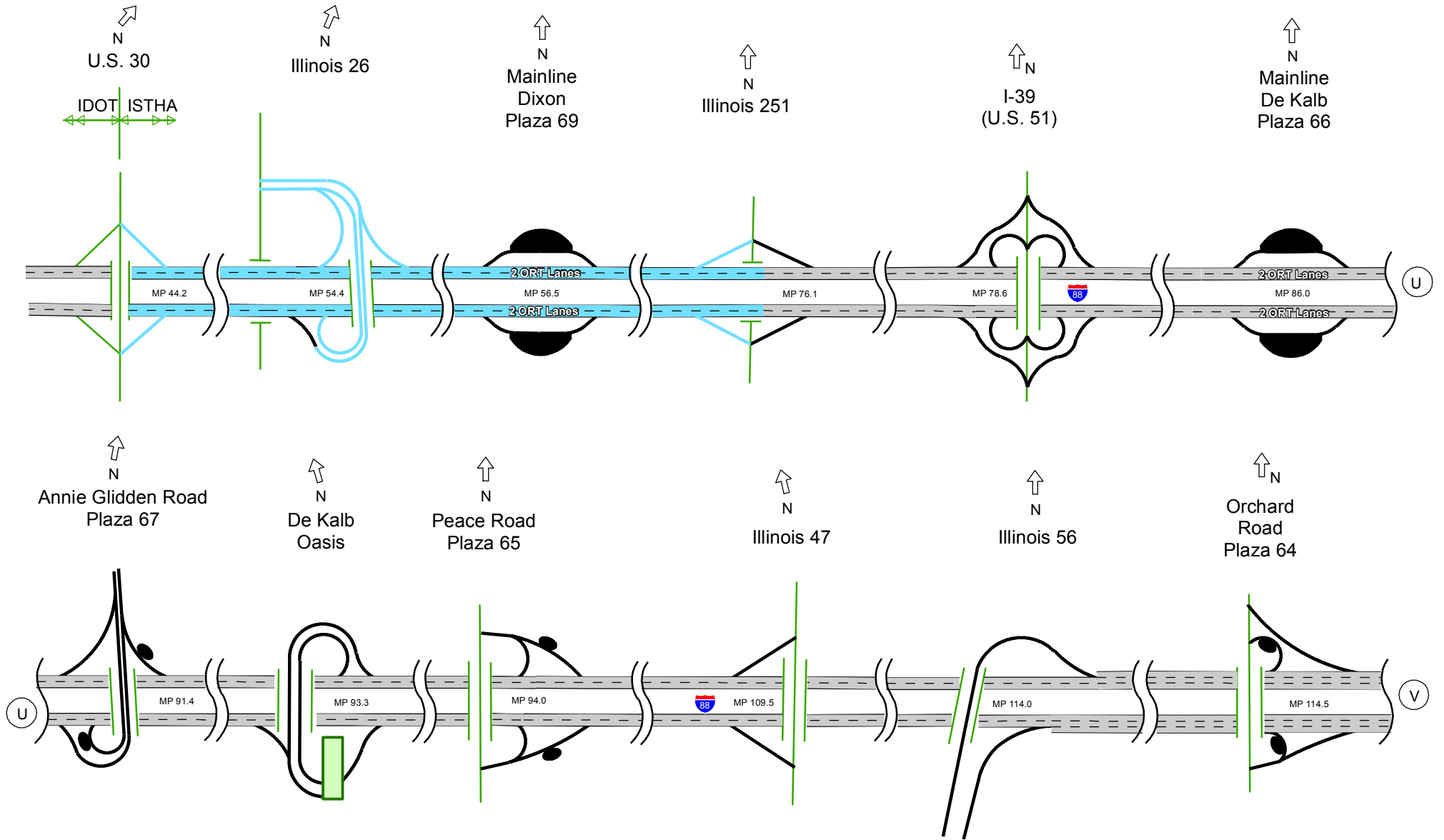



2016 Lane Configuration

On Reagan Memorial Tollway, from Illinois 31 to Illinois 53

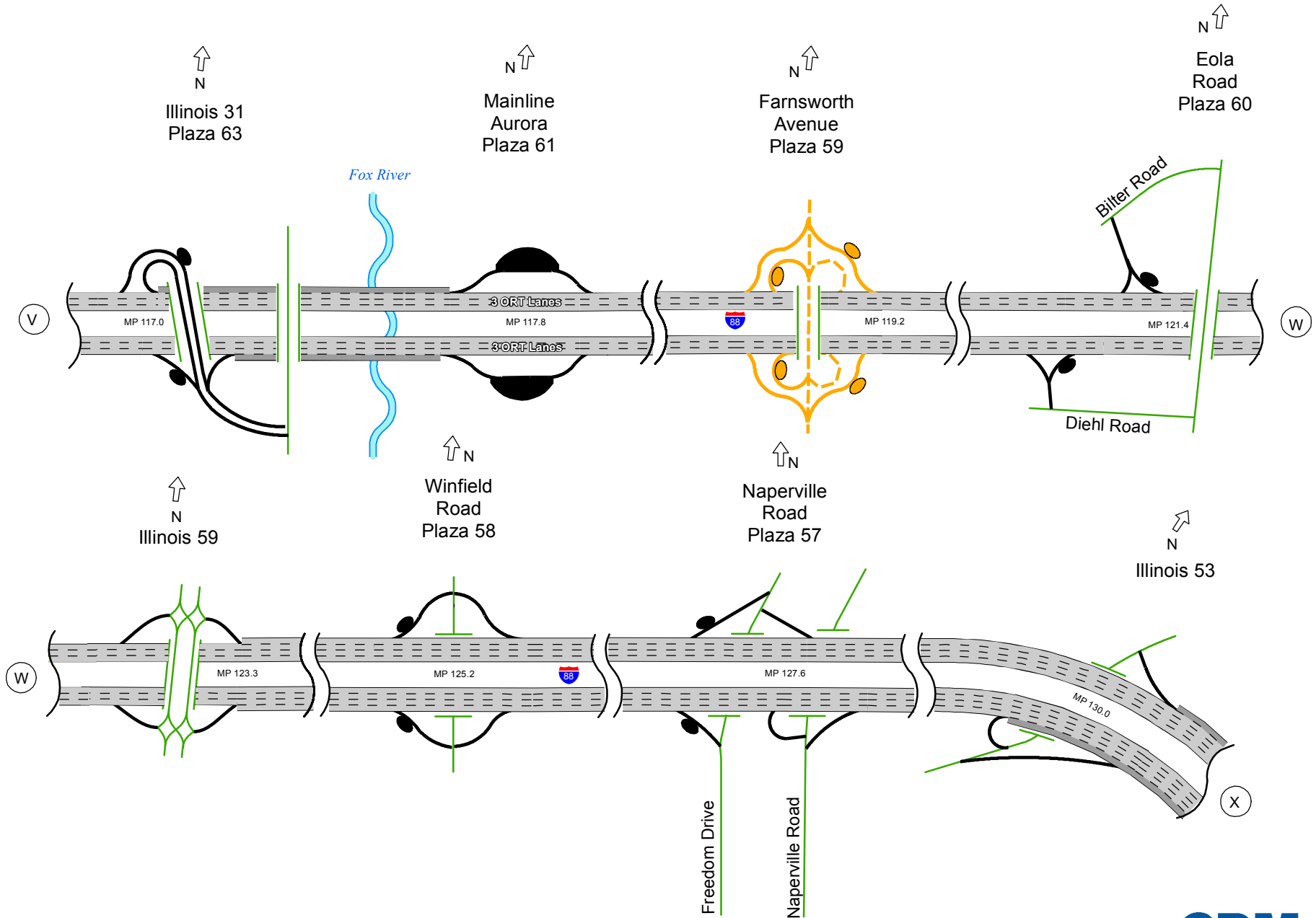

-  Rehabilitation Project
-  Off-System Rehabilitation
-  Construction Project
-  Off-System Construction





2016 Lane Configuration

On Reagan Memorial Tollway, Veterans Memorial Tollway West Interchange

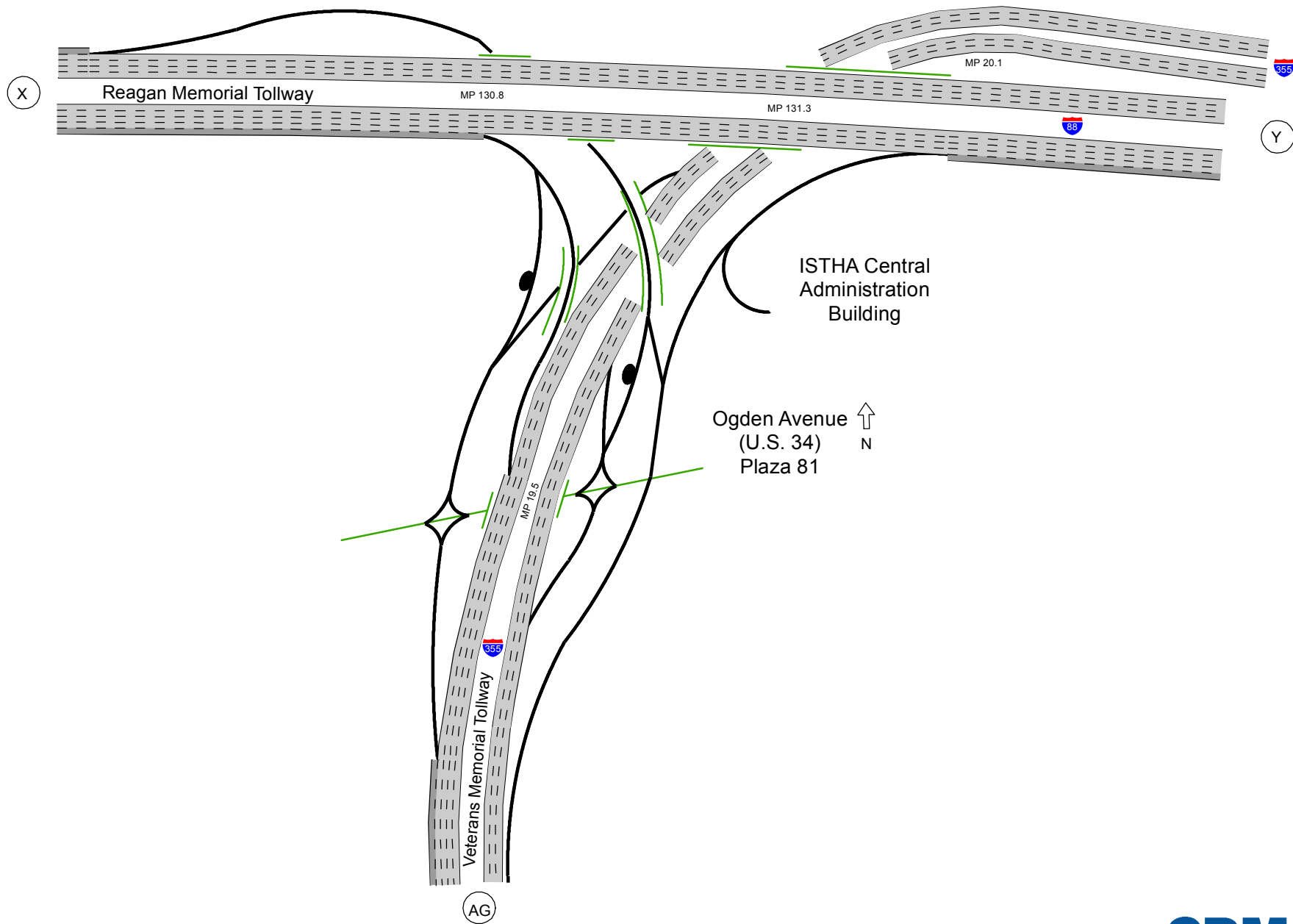

- Rehabilitation Project
- Construction Project
- Off-System Rehabilitation
- Off-System Construction





2016 Lane Configuration

On Reagan Memorial Tollway, Veterans Memorial Tollway East Interchange

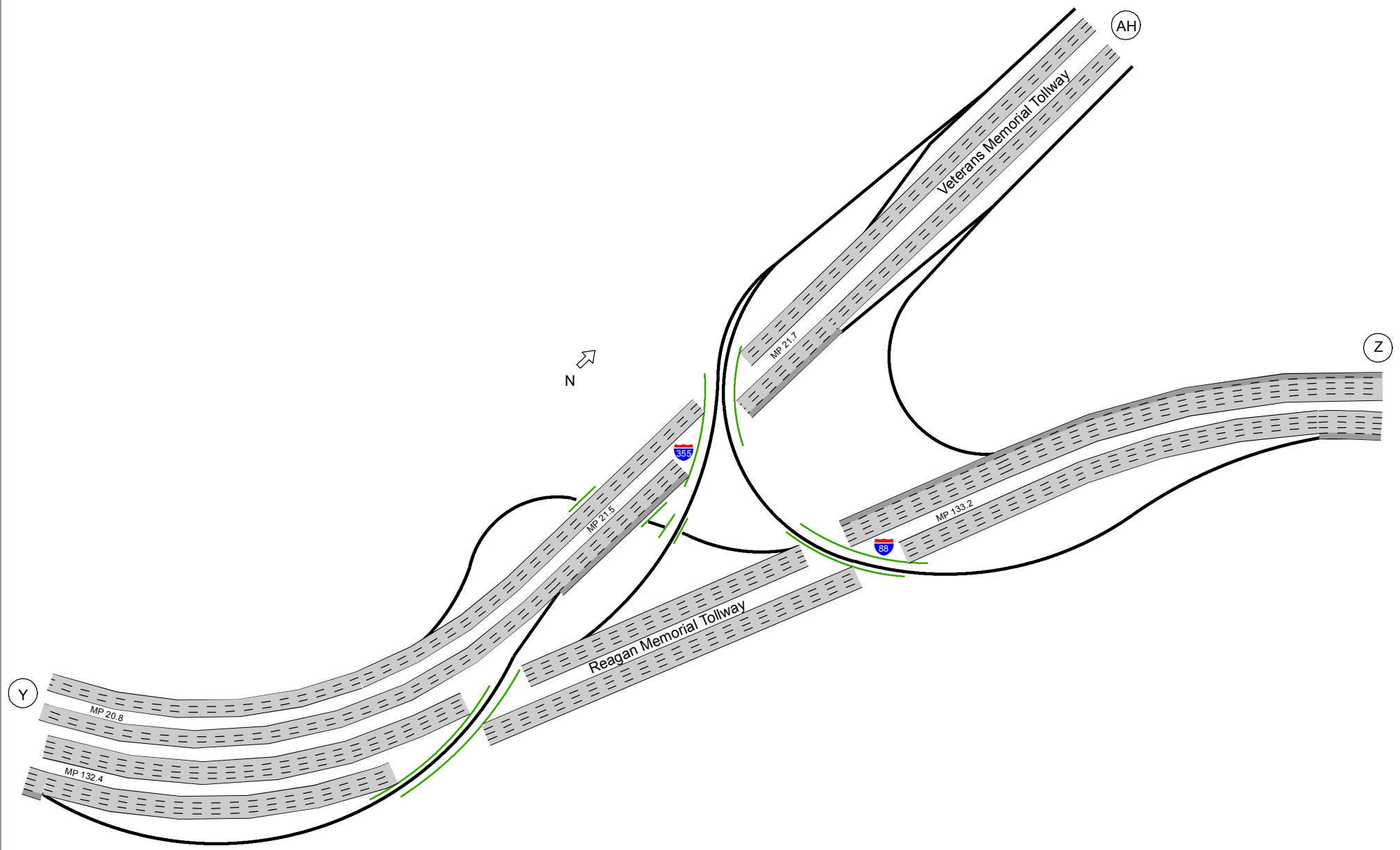

- Rehabilitation Project
- Construction Project
- Off-System Rehabilitation
- Off-System Construction





2016 Lane Configuration

On Reagan Memorial Tollway, from Highland Avenue to Harger Road

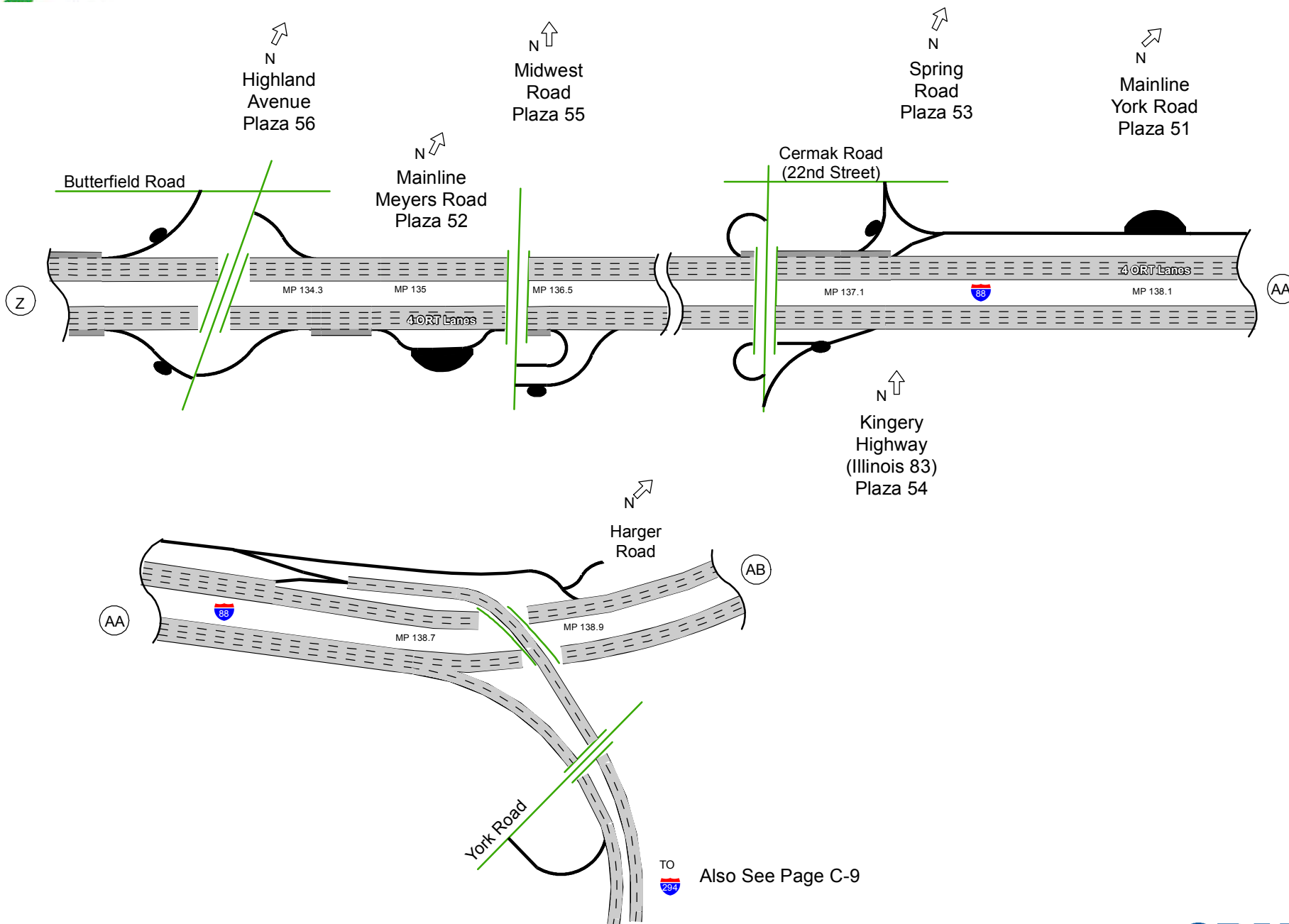

-  Rehabilitation Project
-  Off-System Rehabilitation
-  Construction Project
-  Off-System Construction

TO  Also See Page C-9





2016 Lane Configuration

On Reagan Memorial Tollway, from Roosevelt Road to Eisenhower Expressway (I-290)

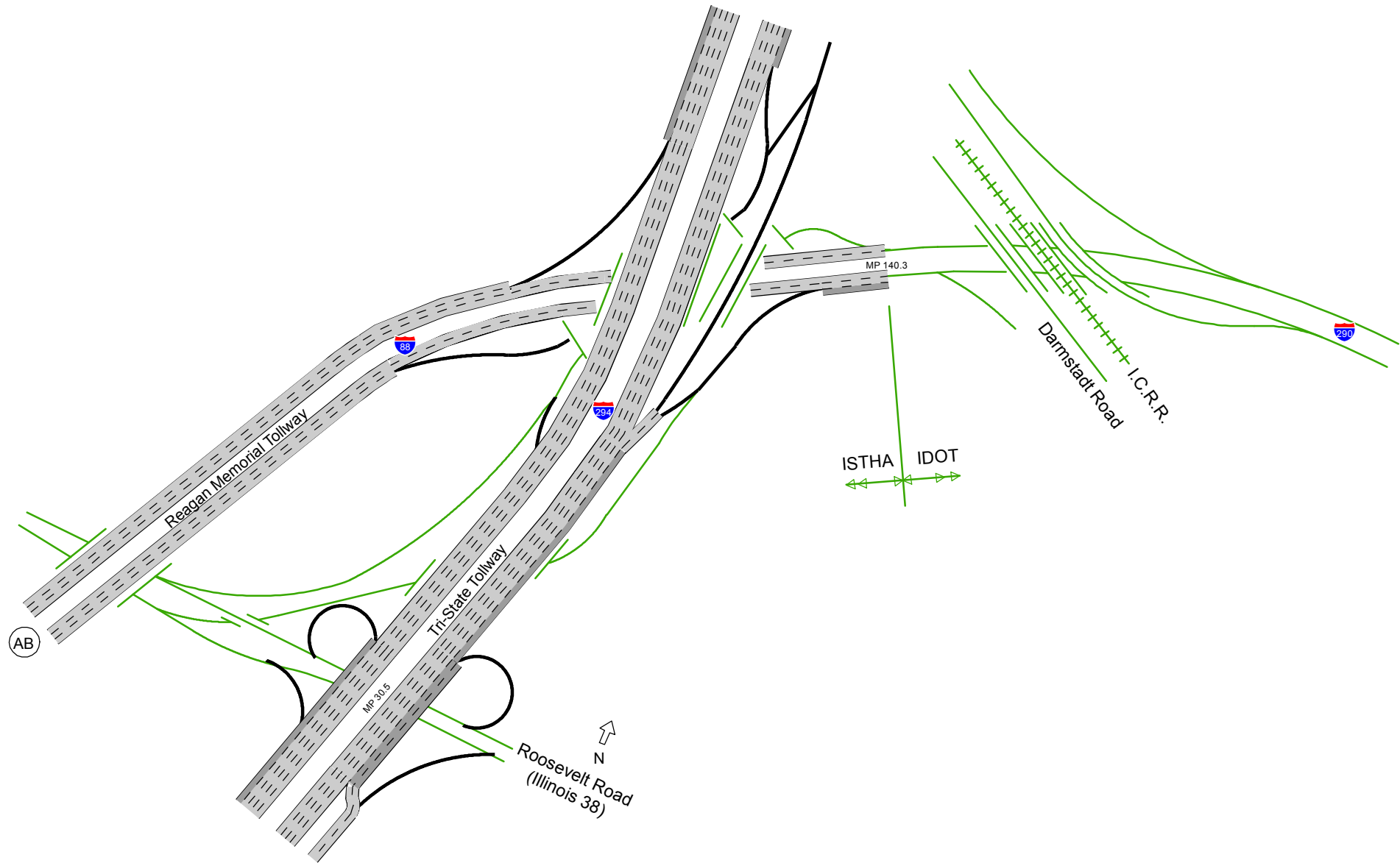

- Rehabilitation Project
- Construction Project
- Off-System Rehabilitation
- Off-System Construction





2016 Lane Configuration

On Veterans Memorial Tollway, from Interstate 80 to 127th Street

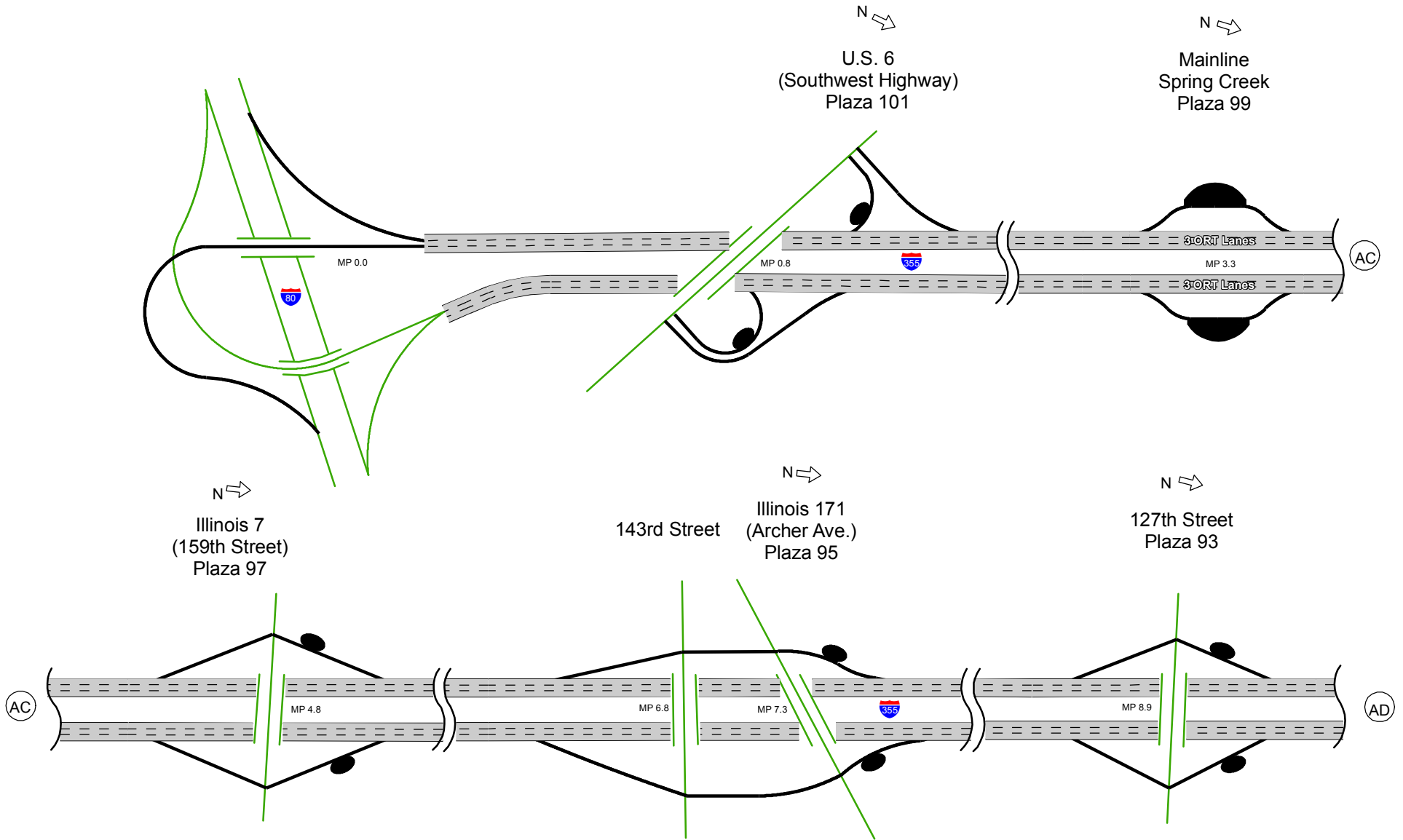

- Rehabilitation Project
- Construction Project
- - - - Off-System Rehabilitation
- - - - Off-System Construction





2016 Lane Configuration

On Veterans Memorial Tollway, At Interstate 55

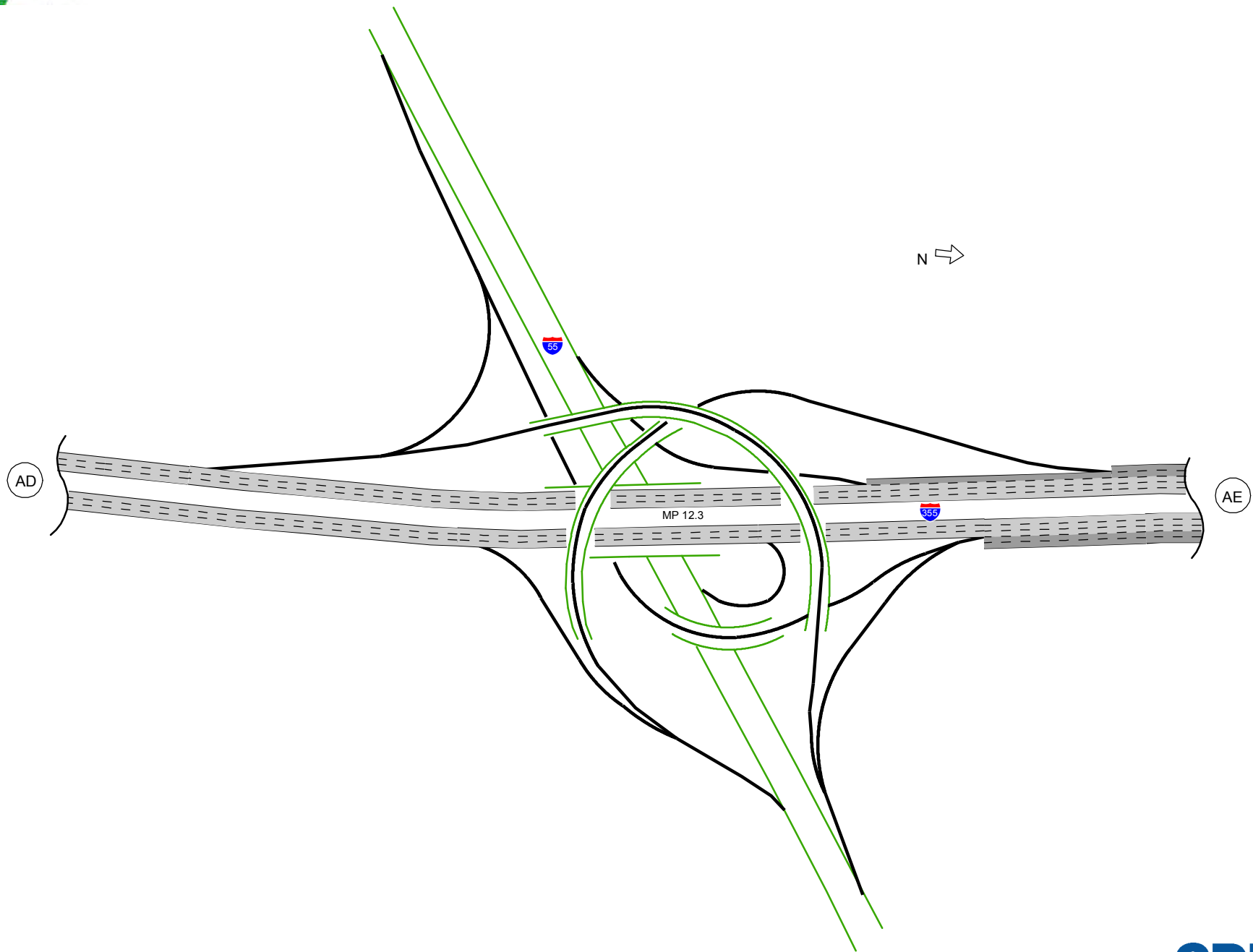

- Rehabilitation Project
- Construction Project
- Off-System Rehabilitation
- Off-System Construction





2016 Lane Configuration

On Veterans Memorial Tollway, from Boughton Road to Maple Avenue

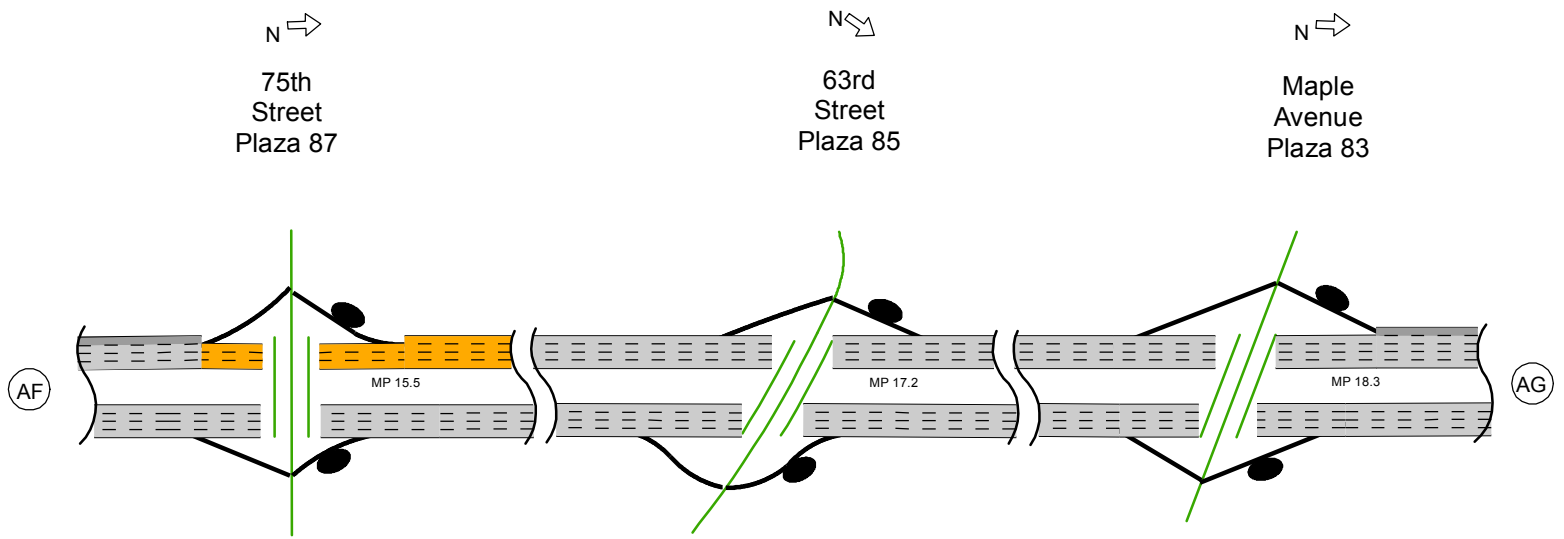
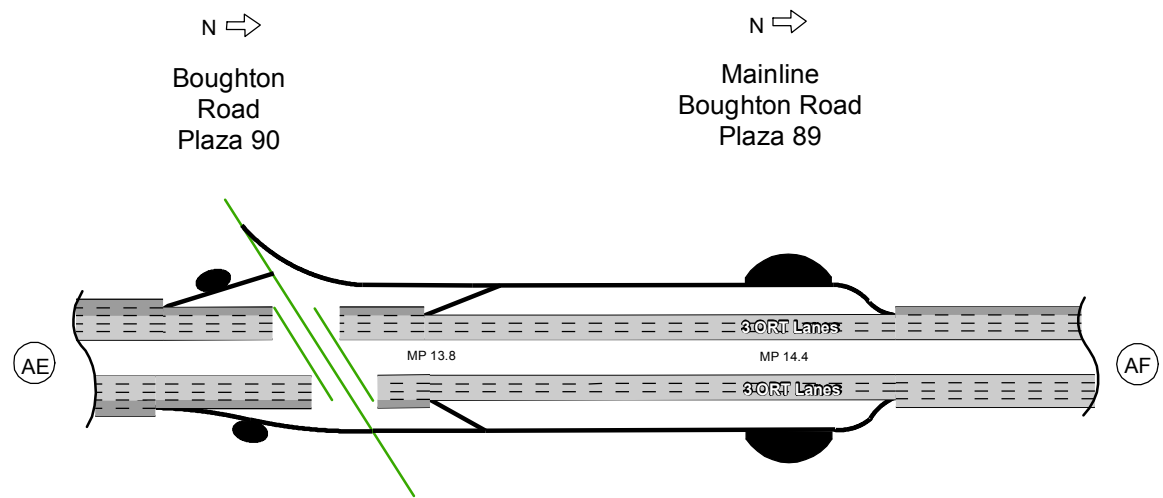

- Rehabilitation Project
- Construction Project
- Off-System Rehabilitation
- Off-System Construction





2016 Lane Configuration

On Veterans Memorial Tollway, from Ogden Avenue / West Interchange to Army Trail Road

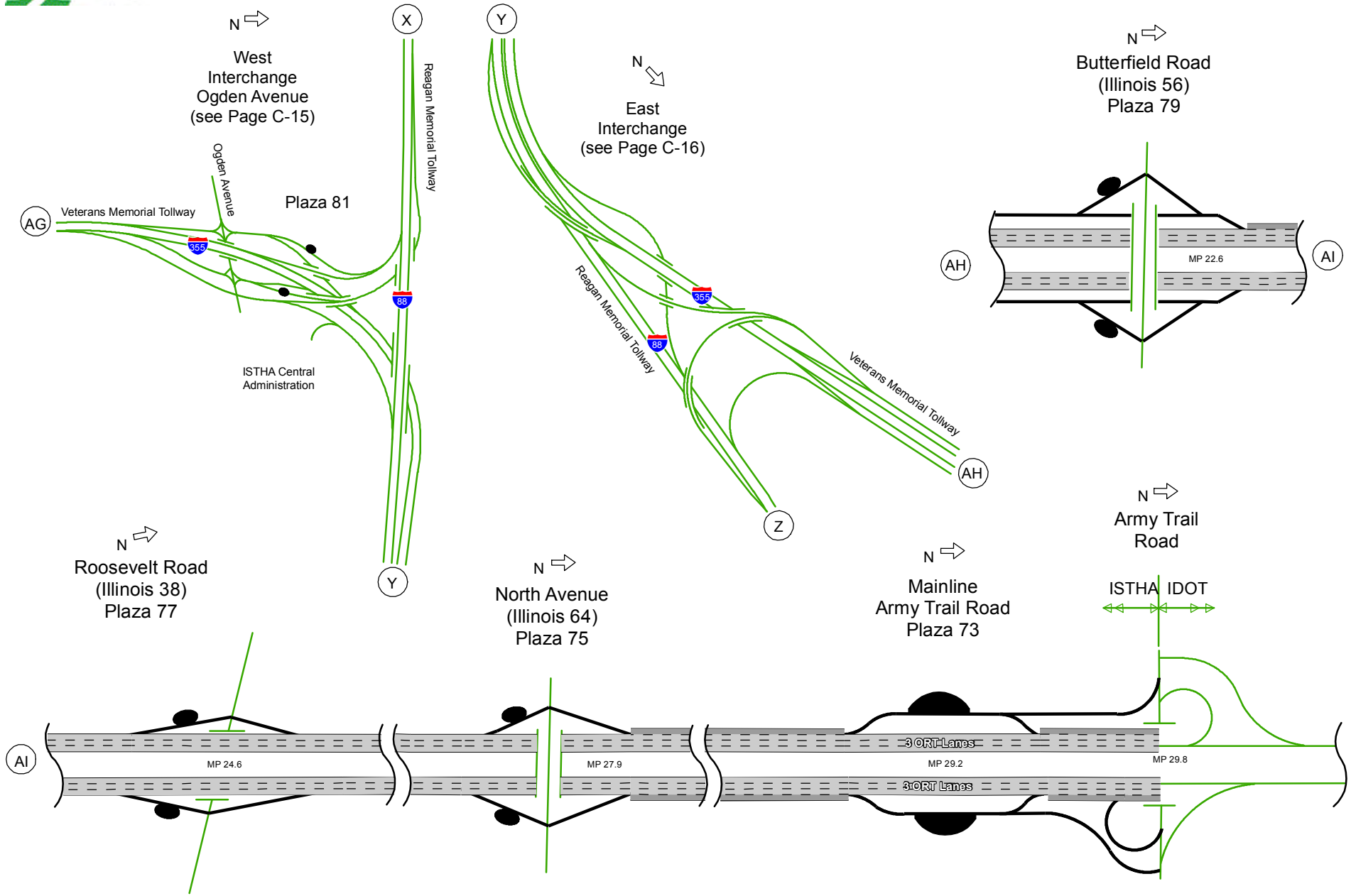

- Rehabilitation Project
- Construction Project
- Off-System Rehabilitation
- Off-System Construction





2016 Lane Configuration

On IL 390, from Lake Street to Plum Grove Road (Plaza 326)

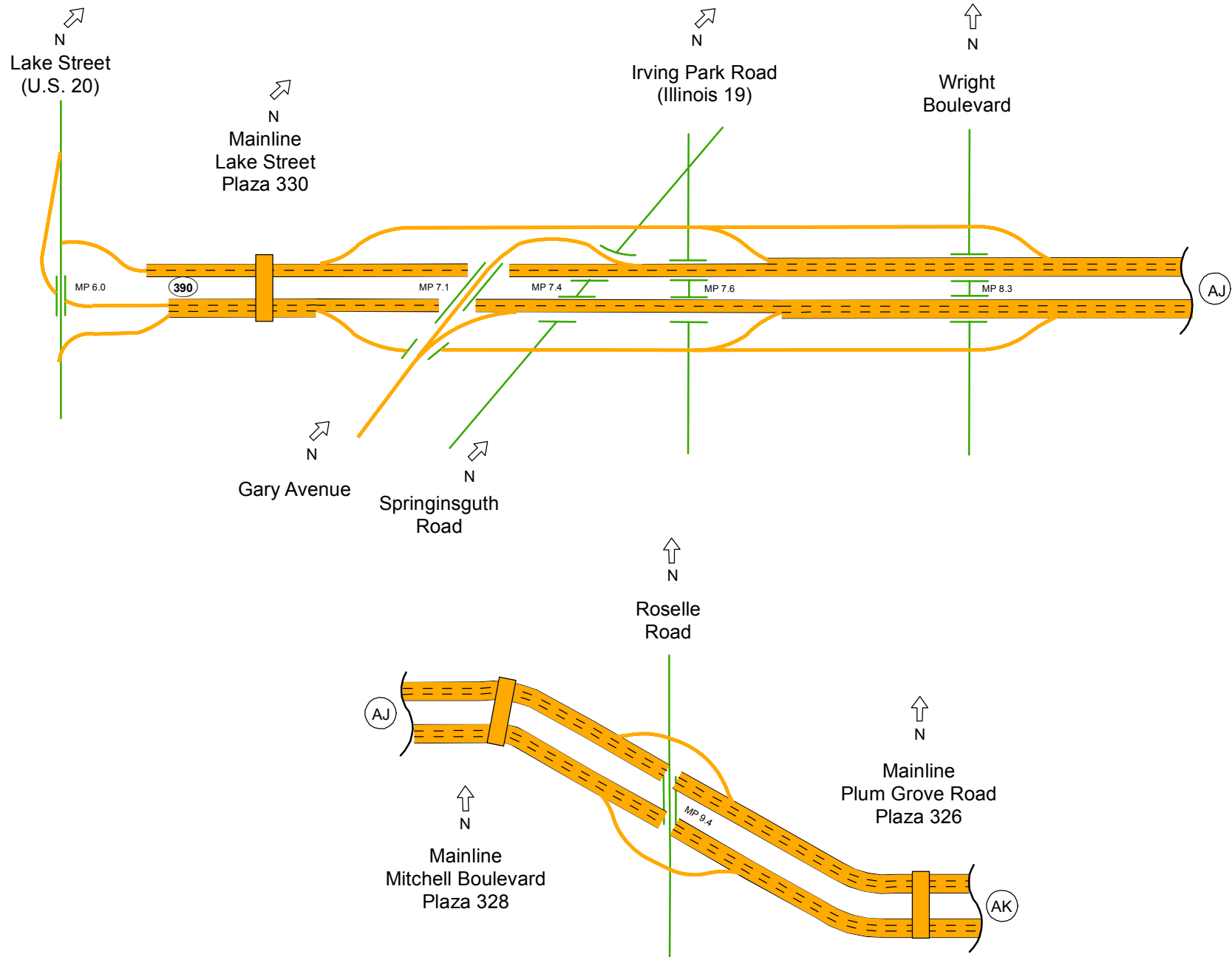

- Rehabilitation Project
- Off-System Rehabilitation
- Construction Project
- Off-System Construction





2016 Lane Configuration

On IL 390, from Plum Grove Road (Plaza 326) to Interstate 290

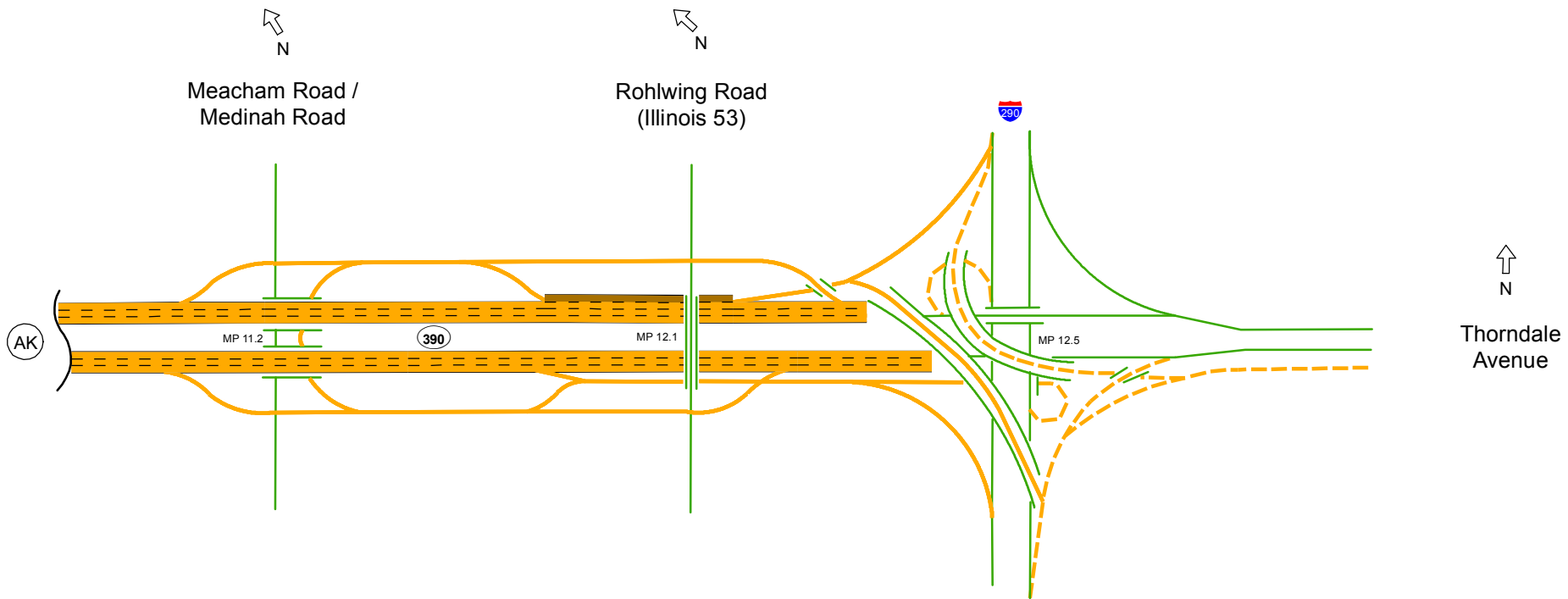

- Rehabilitation Project
- Construction Project
- Off-System Rehabilitation
- Off-System Construction





APPENDIX D

PLAZA LANE LISTING





JANE ADDAMS MEMORIAL TOLLWAY (I-90) PLAZA LANE CONFIGURATION AS OF 12-31-2016

No.	Name	Lane Number														Notes									
		EAST							WEST																
1	South Beloit	71	72	73	74	75	51	52	53	54	55	61	62	63	64	65	81	82	83	84	85	Plaza building on eastbound side			
5	Belvidere											55	54	53	52	51	73	72	71			Serves WB traffic only. Plaza building located on westbound side.			
7	Marengo-Hampshire	75	74		71	72	73	51	52	53	54	55										Serves EB only. Plaza building located on eastbound side between lanes 71 & 74. Lanes 74 & 75 are seasonal lanes.			
9	Elgin		85	84	83	82	81	65	64	63	62	61	55	54	53	52	51	75	74	73	72	71	Plaza building located on westbound side.		
17	Devon Avenue												56	55	54	53	52	51	76	75	74	73	72	71	Serves WB traffic only. Plaza building located on westbound side.
19	River Road	71	72	73	74	75	76																		Serves EB traffic only. Plaza building located on eastbound side.

No.	Name	Lane Number														Notes									
		EAST							WEST																
2	E. Riverside Boulevard																								Lanes 1 & 2 exit I-90 WB to East Riverside Blvd. Lane 1 is eastmost. Lanes 3 & 4 enter I-90 EB from East Riverside Blvd.
3	Genoa Rd																								Toll collection at Genoa Road began in September 2015.
4	Illinois Route 173																								Lanes 3 & 4 exit I-90 WB to IL 173. Lanes 1 & 2 enter I-90 EB from IL 173.
5A	Irene Road																								Irene Road tolled ramps opened December 2015. Toll collection began in 2016.
6	Illinois Route 47																								Lanes 54 & 55 enter I-90 WB. Lanes 51-53 exit I-90 WB to IL 47. Lanes 64 and 65 exit I-90 EB. Lanes 61-63 enter I-90 EB from IL 47.
8	Randall Road																								Lanes 1 & 2 exit I-90 EB to Randall Rd. Lanes 3 & 4 enter I-90 WB from Randall Rd.
10	Barrington Road																								Lanes exit I-90 WB to Barrington Rd. Lane 4 (closest to the mainline) was removed in 2014.
11	Illinois Route 31																								Lanes 1 & 5 exit I-90 WB to IL 31 NB. Lanes 2, 51 & 52 enter I-90 EB from IL 31 NB. Lane 3 enters I-90 EB from IL 31 SB. Lane 4 exits I-90 WB to IL 31 SB.
12	Roselle Road																								Lanes 1, 2 & 3 exit I-90 WB to Roselle Rd. Lanes 4, 54 & 55 enter I-90 EB from Roselle Rd. Lanes 51 & 52 exit I-90 EB to Roselle Rd. EB tolling began November 2016.
12A	Meacham Road																								Meacham Road tolled ramps opened November 2016. Lane 63 exits I-90 WB to Meacham Rd. Lane 61 enters I-90 WB from Meacham Rd.
13	Illinois Route 25																								Lanes 1 & 3 enter I-90 EB from IL 25. Lanes 2 & 4 exit I-90 WB to IL 25.
14	Illinois Route 59																								Lanes 4 - 6 exit I-90 EB to IL 59. Lane 4 is closest to mainline.
15	I-290, Illinois Route 53																								Lanes 1 & 2 exit I-90 EB to IL 53 NB. Lanes 4 - 7 exit I-90 EB to IL 53 SB. Lane 4 is closest to mainline.
16a	Illinois Route 59																								Lanes 7 - 9 exit I-90 WB to IL 59. Lane 9 closest to mainline. Signed as 14 on plaza canopy.
16b	Beverly Road																								Lanes 10 & 11 exit I-90 WB to Beverly Rd. Signed as 14A on plaza canopy. Lane 11 is closest to mainline.
18	Arlington Heights Road																								Lanes 1 - A1/A127 3 enter I-90 WB from Arlington Heights Rd. Lane 1 is northmost. Lanes 4 - 6 exit I-90 EB to Arlington Heights Rd.

	Count
Open Road/All Electronic Tolling (ORT/AET)	44
Manual Lane Toll (MLT)	35
Shoulder	21
I-PASS Only Lane (IPO)	28
Automatic Coin Machine Lane (ACM)	25
X = Closed During Construction	4
II = Center line/Main line	-
Λ = Change in Movement/Direction	-





TRI-STATE TOLLWAY (I-94/I-294) PLAZA LANE CONFIGURATION AS OF 12-31-2016

Mainline Plaza	Lane Number														Notes							
	SOUTH / EAST							NORTH / WEST														
No.	Name	85	84	83	82	81	65	64	63	62	61	55	54	53	52	51	74	73	72	71		
21	Waukegan										61	54	53	52	51		74	73	72	71	Plaza building located on east side.	
24	Edens Spur										54	62	63	64	81		82	83	84		Plaza building located on south side.	
29	Touhy Avenue											56	55	54	53	52	51	77	76	75	74	Serves NB traffic only. Plaza building located on east side.
33	Living Park Road										56	55	54	53	52	51	77	76	75	74	Serves SB traffic only. Plaza building located on west side.	
35	Cermak Road										61	56	55	54	53	52	51	77	76	75	74	Plaza building located on east side.
36	82nd Street										56	55	54	53	52	51	75	74	73	72	Serves SB traffic only. Plaza building located on west side.	
39	83rd Street										61	56	55	54	53	52	51	75	74	73	72	Serves NB traffic only. Plaza building located on east side.
41	163rd Street										61	56	55	54	53	52	51	76	74	73	72	Main plaza building located on east side.

Ramp Plaza	Lane Number														Notes									
	SOUTH / EAST							NORTH / WEST																
No.	Name	4	3	2	1			4	3	2	1			53	52	51								
20	Buckley Road							4	3	2	1											Lanes 1 & 2 enter I-94 NB. Lane 1 is eastmost. Lanes 3 & 4 exit I-94 SB. Lane 4 is westmost.		
22	Townline Road (IL 60)							4	3	2	1											Lanes 1 & 2 enter I-94 NB. Lane 1 is eastmost. Lanes 3 & 4 exit I-94 SB. Lane 4 is westmost.		
23	Half Day Road							4	3	2	1											Lanes 1 & 2 enter I-94 NB. Lane 1 is eastmost. Lanes 3 & 4 exit I-94 SB. Lane 4 is westmost.		
26	Lake Cook Road							7	8	9	10	11	12									Lanes 10 - 12 enter I-294 NB. Lane 12 is eastmost. Lanes 7 - 9 exit I-294 SB. Lane 7 westmost.		
27	Willow Road							14	13	12	11	10	9									Lanes 9 - 11 enter I-294 NB. Lane 9 is eastmost. Lanes 12 - 14 exit I-294 SB. Lane 14 is westmost.		
28	Golf Road							6	5	4	3	2	1									Lanes 1 - 3 enter I-294 NB. Lane 1 is eastmost. Lanes 4 - 6 exit I-294 SB. Lane 6 is westmost.		
30	Balmoral Avenue													53	52	51					Lanes 51-53 exit I-294 NB. Lane 53 is westmost.			
31	O'Hare West							1	2	3	4											Lane 1 is closest to the plaza building (northmost).		
32	O'Hare East													4	3	2	1					Lane 1 is closest to the plaza building (southmost).		
34	75th Street							1	2	3	4	5	6									Lanes 1 - 3 exit I-294 SB. Lanes 4 - 6 enter I-294 NB.		
37	I-55							1	2	3	4	5	6	7	8	9	10					Lanes 1 - 5 exit I-294 SB. Lane 1 is closest to the plaza building (westmost). Lanes 6 - 10 enter I-294 NB. Lane 10 is eastmost.		
38	95th Street													4	3	2	1					Lanes 1 & 2 exit I-294 NB. Lane 1 is eastmost. Lanes 3 & 4 enter I-294 SB. Lane 4 is westmost.		
40	159th Street							8	7	6	5	4	3	2	1						Lanes 1 & 2 enter NB I-294 from WB 159th St. Lanes 3 & 4 enter NB I-294 from EB 159th St. Lanes 5 & 6 exit SB I-294 to EB 159th St. Lanes 7 & 8 exit SB I-294 to WB 159th St.			
42	I-57 (interchange)							64	65	66	63	62	61	56	55	54	53	52	51					Lanes 52-53 enter NB I-294 from 147th Street. Lanes 55-56 enter NB I-294 from NB I-57. Lanes 61-62 exit SB I-294 to 147th Street. Lanes 65-66 exit SB I-294 to SB I-57.
43	I-80, Westbound																					Plaza to continue on I-80 WB from the southernmost portion of the Tri-State Tollway.		
45	I-80, Eastbound							71	72	73	74	51	52	53	54							Plaza to enter the southernmost portion of the Tri-State Tollway from I-80 EB.		
47	Halsted Street													6	5	4	3	2	1					Lanes 1 - 3 exit NB I-294 to Halsted St. Lane 1 is closest to the control building (northmost). Lanes 4 - 5 enter SB I-294 from Halsted St.

	Count
Open Road/All Electronic Tolling (ORT/AET)	56
Manual Lane Toll (MLT)	64
Shoulder	33
I-PASS Only Lane (IPO)	45
Automatic Coin Machine Lane (ACM)	34
Closed Lane/Other	3
II = Center line/Main line	-
Λ = Change in Movement/Direction	-





REAGAN MEMORIAL TOLLWAY (I-88) PLAZA LANE CONFIGURATION AS OF 12-31-2016

No.	Name	Mainline Plaza										Notes					
		EAST					WEST										
		Lane Number															
		II					II										
51	York Road						51	52	53	54	55	56	57	58	59	60	Serves WB traffic only. Plaza building located on north side.
52	Meyers Road	71	72	73	74	75	76	77	78	79	80	81	82	83	84	85	Serves EB traffic only. Plaza building located on south side.
61	Aurora	71	72	73	74	75	76	77	78	79	80	81	82	83	84	85	Plaza building located on south side
66	Dekalb	71	72	73	74	75	76	77	78	79	80	81	82	83	84	85	Plaza building located on south side
69	Dixon	83	82	81	80	79	78	77	76	75	74	73	72	71	70	69	Plaza building located on north side
		Lane Number															
		EAST					WEST										
		II					II										
53	Spring Road																All lanes enter I-88 WB from Spring Rd. Lane 1 is eastmost.
54	Illinois Route 83																All lanes enter I-88 EB from IL 83.
55	Midwest Road																All lanes enter I-88 EB from Midwest Rd.
56	Highland Avenue																Lanes 1 & 2 enter I-88 WB from Downiers Dr. Lane 1 is westmost. Lanes 3 & 4 exit I-88 EB to Highland Ave. Lane 4 is southmost.
57	Naperville Road																Lanes 4 & 5 enter I-88 WB from Naperville Rd. Lanes 2 & 3 exit I-88 EB to Naperville Rd.
58	Winfield Road																Lanes 5 & 6 exit I-88 EB to Winfield Rd. Lane 5 is southmost. Lanes 7 & 8 enter I-88 WB from Winfield Rd. Lane 8 is closest to mainline.
59	Farnsworth Avenue																Lanes 1 & 5 exit I-88 WB to NB Farnsworth Ave. Lane 2 enters I-88 EB from NB Farnsworth Ave. Lanes 3 & 7 enter I-88 EB from SB Farnsworth Ave. Lane 4 exits I-88 WB to SB Farnsworth Ave.
60	Eola Road																Lanes 52 & 53 exit I-88 WB to Blitter Rd. Lane 53 is westmost. Lanes 62 & 63 enter I-88 EB from Diehl Rd. Lane 63 is westmost.
63	Illinois Route 31																Lane 1 enters I-88 WB from IL 31. Lane 2 exits I-88 EB to IL 31.
64	Orchard Road																Lanes 1 & 2 enter I-88 WB from Orchard Rd. Lane 2 is northmost. Lanes 3 & 4 exit I-88 EB to Orchard Rd. Lane 4 is southmost.
65	Peace Road																Lanes 1 & 2 exit I-88 WB to Peace Rd. Lane 1 is northmost. Lanes 3 & 4 enter I-88 EB from Peace Rd. Lane 4 is southmost.
67	Annie Glidden Road																Lanes 3 & 4 exit I-88 WB to Annie Glidden Rd. Lanes 1 & 2 enter I-88 EB from Annie Glidden Rd.

	Count
Open Road/All Electronic Tolling (ORT/AET)	26
Manual Lane Toll (MLT)	28
Shoulder	17
I-PASS Only Lane (IPO)	19
Automatic Coin Machine Lane (ACM)	22
Closed Lane/Other	10
II = Center line/Main line	-
Λ = Change in Movement/Direction	-





VETERANS MEMORIAL TOLLWAY (I-355) PLAZA LANE CONFIGURATION AS OF 12-31-2016

Mainline Plaza		Lane Number														Notes								
No.	Name	SOUTH							NORTH															
73	Army Trail	71	72	73	74	75	76	51	52	53	54	55	II	61	62	63	64	65	81	82	83	84	85	Plaza building located on west side.
89	Boughton Road	71	72	73	74	75	76	51	52	53	54	55	II	61	62	63	64	65	81	82	83	84	85	Plaza building located on west side.
99	Spring Creek												II	55	54	53	52	51	73	72	71			Plaza building located on east side.
Ramp Plaza		Lane Number														Notes								
No.	Name	SOUTH						NORTH																
75	North Avenue							6	5	4	II	3	2	1										Lanes 1 - 3 exit I-355 NB to North Ave. Lane 1 is eastmost.
77	Roosevelt Road											1	2	II	3	4								Lanes 1 & 2 enter I-355 SB from Roosevelt Rd. Lane 1 is closest to control building (westmost). Lanes 3 & 4 exit I-355 NB to Roosevelt Rd. Lane 4 is eastmost.
79	Butterfield Road											1	2	II	3	4								Lanes 1 & 2 enter I-355 SB from Butterfield Rd. Lane 1 is closest to control building (westmost). Lanes 3 & 4 exit I-355 NB. Lane 4 is eastmost.
81	Ogden Avenue											1	2	II	3	4								Lanes 1 & 2 exit I-88 EB to Ogden Ave. Lane 1 is westmost. Lanes 3 & 4 enter I-88 WB from Ogden Ave. Lane 4 is eastmost.
83	Maple Avenue											1	2	3	II	4	5	6						Lanes 1 - 3 exit I-355 SB to Maple Ave. Lane 1 is westmost. Lanes 4 - 6 enter I-355 from Maple Ave. Lane 6 is eastmost.
85	63rd Street											6	5	4	II	3	2	1						Lanes 1 - 3 enter I-355 NB from 63rd St. Lane 1 is eastmost. Lanes 4 - 6 exit I-355 SB to 63rd St. Lane 6 is westmost.
87	75th Street											6	5	4	II	3	2	1						Lanes 1 - 3 enter I-355 NB from 75th St. Lane 1 is eastmost. Lanes 4 - 6 exit I-355 SB to 75th St. Lane 6 is westmost.
90	Boughton Road											1	2	II	3	4								Lanes 1 & 2 enter I-355 SB from Boughton Rd. Lanes 3 & 4 exit I-355 NB to Boughton Rd.
93	127th Street																							Lanes 3 & 4 enter I-355 NB from 127th St. Lanes 1 & 2 exit I-355 SB to 127th St.
95	Archer Avenue																							Lanes 3 & 4 enter I-355 NB from Archer Ave. Lanes 1 & 2 exit I-355 SB to Archer Ave.
97	159th Street																							Lanes 3 & 4 enter I-355 NB from IL 7. Lanes 1 & 2 exit I-355 SB to IL 7.
101	U.S. Route 6																							Lanes 3 & 4 enter I-355 SB from Route 6. Lanes 1 & 2 exit I-355 NB to US 6.

	Count
Open Road/All Electronic Tolling (ORT/AET)	18
Manual Lane Toll (MLT)	20
Shoulder	12
I-PASS Only Lane (IPO)	37
Automatic Coin Machine Lane (ACM)	24
Closed Lane/Other	4
II = Center line/Main line	-
Δ = Change in Movement/Direction	-





ILLINOIS ROUTE 390 TOLLWAY (IL 390) PLAZA LANE CONFIGURATION AS OF 12-31-2016

No.	Name	Lane Number												Notes
		EAST						WEST						
326	Plum Grove	51	52	53	54	55	II	61	62	63	64	65		
328	Michell Road	51	52	53	54	55	II	61	62	63	64	65		
330	Lake St	51	52	53	54	55	II	61	62	63	64	65		

	Count
Open Road/All Electronic Tolling (ORT/AET)	17
Manual Lane Toll (MLT)	0
Shoulder	13
I-PASS Only Lane (IPO)	0
Automatic Coin Machine Lane (ACM)	0
Closed Lane/Other	0
II = Center line/Main line	-
∧ = Change in Movement/Direction	-

