

2012 Traffic Data Report

for the Illinois Tollway System





2012 Traffic Data Report

For The Illinois Tollway System

Prepared for
Illinois State Highway Authority



Prepared by:

**CDM
Smith**





CONTENTS

SECTION 1:	THE ILLINOIS TOLLWAY SYSTEM
SECTION 2:	JANE ADDAMS MEMORIAL TOLLWAY
SECTION 3:	TRI-STATE TOLLWAY
SECTION 4:	REAGAN MEMORIAL TOLLWAY
SECTION 5:	VETERANS MEMORIAL TOLLWAY
APPENDICES:	
APPENDIX – A:	2012 SYSTEMWIDE ANNUAL AVERAGE DAILY TRAFFIC SCHEMATICS
APPENDIX – B:	2012 SYSTEMWIDE AM AND PM PEAK HOUR TRAFFIC SCHEMATICS
APPENDIX – C:	2012 LANE CONFIGURATION SCHEMATICS
APPENDIX – D:	PLAZA LANE SCHEMATICS

(Please refer to individual sections for detailed Table of Contents)



Section 1 Tab





SECTION 1

The Illinois Tollway System

General Information 1-1

TABULATIONS

TABLE

	PAGE
1-A Systemwide Average Daily Traffic	1-4
1-B Annual Traffic Totals	1-5
1-C Average Daily Traffic Totals	1-5
1-D Systemwide Monthly Factors	1-5
1-E Annual Transactions by Vehicle 2011-2012	1-6
1-F I-Pass Participation Rate 2011-2012	1-6
1-G History of Tollway Additions by Mileage 1959 - 2012	1-7
1-H History of Tollway Additions by Location 1960 - 2012	1-8
1-I Summary of Traffic Characteristics at Plazas (Annual Transactions)	1-13

ILLUSTRATIONS

FIGURE

	PAGE
1-A The Illinois Tollway System 2012	1-15
1-B Average Daily Traffic 2012	1-16
1-C Annual Average Percentage Change in Daily Traffic Volumes 2000 - 2012	1-17
1-D Major Tollway Construction Projects During 2012	1-18
1-E Major Off-Tollway Construction Projects During 2012	1-19



GENERAL INFORMATION

The 2012 Traffic Data Report is intended to provide a snapshot of the average traffic conditions throughout the Tollway system for the year 2012. The primary sources of information for the development of this report are:

- Toll plaza transaction data
- Non-tolled ramp sample traffic counts
- Physical configuration of the Tollway system and connections to other routes
- Historical traffic data for the Tollway system.

The traffic volumes presented in this report for each link of the system are primarily based on toll plaza transaction data. The data were extracted from the Electronic Transaction Consultants' Traffic Activity by Class Report and Hourly Traffic Volume Report run on January 24, 2013. Since transaction data is essentially continuous, accurate annual average daily traffic (AADT) and peak hour traffic volumes may be determined at mainline toll plazas and at tolled ramps. To obtain AADT and peak volumes in intermediate mainline segments and on non-tolled ramps, transaction data is supplemented by sample traffic counts conducted at non-tolled ramps. These sample counts are converted to AADT and peak volumes using seasonal adjustment factors and a balancing algorithm that adjusts non-toll ramp counts so that all mainline volumes are consistent with ramp exiting and entering volumes. The AADT and peak traffic estimates are then validated using historical trends and data.

Conditions influencing local traffic flow frequently cause traffic volumes to vary from historical trends. While major traffic incidents or weather events can have a significant impact on the traffic on a particular day, use of annual averages tends to diminish these types of impacts. On the other hand, some events can have an effect on typical traffic volumes on a long-term basis. One such event was the passenger car toll rate change that took effect in 2012.

In 2011, the Tollway approved the \$12 billion *Move Illinois* capital program. To fund the program, passenger car rates were increased 87.5 percent on January 1, 2012 for both cash and I-PASS users. This rate change increased the typical mainline toll from 40 cents to 75 cents for I-PASS customers, and from 80 cents to \$1.50 for cash customers. Systemwide, passenger car transactions declined 4.2 percent from 2011, largely due to the toll increase.

Any reconfiguration of the Tollway system, such as a new interchange or major capacity improvement, will have a permanent impact on traffic patterns. Additionally, major construction projects extend over many months and are likely to cause a reduction in average traffic volumes on that route and increases in volumes on parallel routes. The following sections of the Illinois Tollway were under construction during 2012:

- Tri-State Tollway (I-94/294/80)
 - Resurfacing – 95th Street to Balmoral Avenue
 - Bridge Reconstruction – NB I-294 to WB I-90 flyover ramp
 - Bridge Reconstruction/Widening – I-294 over 147th Street



- Reagan Memorial Tollway (I-88)
 - Reconstruction/Widening – IL 56 to Orchard Road
 - Resurfacing – IL 251 to IL 56
- Jane Addams Memorial Tollway (I-90/39)
 - Construction of EB Exit and WB Entrance ramps at IL 47
 - Shoulder/bridge widening between Sandwald Road and the Kishwaukee River.

Off-system construction projects in the Tollway service area, particularly those on the expressway system, can also have a significant impact on Tollway traffic volumes. During 2012, construction projects with the potential to impact traffic on the Tollway system included the following:

IDOT EXPRESSWAY SYSTEM

- I-94 – Interchange Reconstruction – Russell Road
- I-39/90 – Reconstruction/Widening – Rockton Road to Wisconsin state line
- I-80 – Add Lanes – US 30 to US 45
- I-55 – Interchange Reconfiguration – Arsenal Road

ARTERIALS

- IL 56 – Reconstruction/Widening – Naperville Road to IL 59, Warrenville
- IL 53 – Reconstruction/Widening – Army Trail Road to Elgin-O'Hare Expressway, Itasca
- IL 47 – Reconstruction/Widening – Reed Road to Kruetzer Road, Huntley
- US 30 – Reconstruction/Widening – IL 43 to William Street, New Lenox
- Rakow Road – Reconstruction/Widening – IL 31 to Ackman Road, Crystal Lake
- Belmont Road – Construction of underpass at BNSF railroad tracks, Downers Grove

The above projects may have caused variations in traffic patterns affecting Tollway traffic to varying degrees and may be positive or negative. These impacts are not individually quantified, but serve to illustrate the need for the reader to be cautious when using average daily or peak hour volumes from a single year.

DEFINITIONS AS USED HEREIN

Traffic volumes are balanced over the entire system so that mainline and ramp volumes are consistent along a route; therefore the listed volumes are a precise numerical average only in locations where there is a toll plaza and complete data is available. Three types of traffic volumes are provided in this report and are defined on the next page.



Annual Average Daily Traffic (AADT) Volume -- is an approximation of the numerical average daily traffic volume for each day of 2012.

AM Peak Hour Volume -- is an approximation of the 85th percentile hourly traffic volume in the highest AM hours (6:00-8:00 AM) on all Mondays through Thursdays in 2012, excluding holidays.

PM Peak Hour Volume -- is an approximation of the 85th percentile hourly traffic volume in the highest PM hours (4:00-6:00 PM) on all Mondays through Thursdays in 2012, excluding holidays.

Weekends – consist of Fridays, Saturdays, and Sundays that do not fall on holidays.

HOLIDAYS

Due to differing traffic patterns, major holidays are classified separately from weekdays and weekends. Additionally, the day immediately preceding some holidays are considered a holiday for the purpose of this Report. Below is a list of holidays and their dates in 2012.

New Years	Monday, January 2
Memorial Day	Friday, May 25
	Monday, May 28
Independence Day	Wednesday, July 4
Labor Day	Friday, August 31
	Monday, September 3
Thanksgiving	Wednesday, November 21
	Thursday, November 22
	Friday, November 23
Christmas	Monday, December 24
	Tuesday, December 25
New Years	Monday, December 31



TABLE 1-A: SYSTEM WIDE AVERAGE DAILY TRAFFIC DATA

Year	Average Daily Total			Average Trip
	Vehicles	Vehicle Miles	Transactions	Length (miles)
1959	62,321	1,753,465	117,637	28.14
1960	87,358	2,346,638	160,973	26.86
1961	109,731	2,659,991	194,577	24.24
1962	132,668	2,985,415	222,322	22.50
1963	134,818	2,878,143	211,939	21.35
1964	138,876	2,971,427	217,831	21.40
1965	158,170	3,303,069	247,469	20.88
1966	172,263	3,705,230	283,152	21.51
1967	186,379	3,973,250	313,648	21.32
1968	206,449	4,376,634	368,342	21.20
1969	238,245	4,821,981	440,997	20.24
1970	254,586	5,180,119	485,214	20.35
1971	279,326	5,669,283	533,241	20.30
1972	303,014	5,892,861	561,173	19.45
1973	342,322	6,353,650	621,905	18.56
1974	349,315	6,450,658	637,824	18.47
1975	369,435	6,780,810	666,002	18.35
1976	404,502	7,356,671	723,102	18.19
1977	431,215	7,850,792	770,872	18.21
1978	465,613	8,392,536	824,085	18.02
1979	479,525	8,685,523	851,116	18.11
1980	472,518	8,578,161	842,742	18.15
1981	493,226	8,846,114	866,299	17.94
1982	500,961	8,820,121	869,866	17.61
1983	527,505	9,273,782	906,308	17.58
1984	544,532	9,779,084	958,999	17.96
1985	587,614	10,283,396	1,008,812	17.50
1986	629,278	11,295,635	1,102,413	17.95
1987	672,160	11,689,569	1,172,861	17.39
1988	721,177	12,902,373	1,269,782	17.89
1989	745,381	13,323,423	1,307,767	17.87
1990	896,699	14,672,385	1,487,801	16.36
1991	946,112	14,913,846	1,547,094	15.76
1992	993,920	15,290,401	1,572,740	15.38
1993	1,034,054	15,612,752	1,607,475	15.10
1994	1,041,362	17,231,387	1,732,312	16.55
1995	1,088,510	18,271,480	1,827,959	16.79
1996	1,123,270	18,878,017	1,890,858	16.81
1997	1,193,230	19,316,298	1,941,011	16.19
1998	1,218,030	19,550,833	1,984,130	16.05
1999	1,247,410	20,374,456	1,972,261	16.33
2000	1,277,940	20,647,836	2,011,583	16.16
2001	1,322,130	21,431,414	2,088,631	16.21
2002	1,337,005	22,274,640	2,153,241	16.66
2003	1,363,990	22,791,808	2,196,240	16.71
2004	1,404,110	23,382,734	2,249,030	16.65
2005	1,344,410	22,381,137	2,138,209	16.65
2006	1,333,990	22,184,397	2,093,494	16.63
2007	1,412,430	22,775,523	2,159,704	16.13
2008	1,382,450	22,005,034	2,125,361	15.92
2009	1,381,050	21,951,844	2,124,254	15.90
2010	1,445,500	23,363,833	2,238,582	16.16
2011	1,464,450	23,713,815	2,287,292	16.19
2012	1,425,550	22,776,184	2,196,121	15.98



TABLE 1-B: ANNUAL TRAFFIC TOTALS

Tollway Route	Vehicles	Vehicle Miles			Transactions
		PC	CV	Total	
Jane Addams Memorial	113,009,820	1,825,352,884	302,550,986	2,127,903,870	166,961,815
Tri-State	230,089,560	3,157,715,257	549,270,725	3,706,985,982	344,330,297
Reagan Memorial	88,787,940	1,592,924,998	209,841,308	1,802,766,306	136,693,317
Veterans Memorial	89,863,980	955,874,146	85,725,986	1,041,600,132	155,794,902
Total	521,751,300	7,531,867,285	1,147,389,005	8,679,256,290	803,780,331

TABLE 1-C: AVERAGE DAILY TRAFFIC TOTALS

Tollway Route	Vehicles	Vehicle Miles			Transactions
		PC	CV	Total	
Jane Addams Memorial	308,770	4,987,303	826,642	5,813,945	456,180
Tri-State	628,660	8,627,637	1,500,740	10,128,377	940,793
Reagan Memorial	242,590	4,352,254	573,337	4,925,591	373,479
Veterans Memorial	245,530	2,611,678	234,224	2,845,902	425,669
Total	1,425,550	20,578,872	3,134,943	23,713,815	2,196,121

TABLE 1-D: SYSTEMWIDE MONTHLY FACTORS

Month	Factor
January	0.90
February	0.90
March	0.99
April	0.98
May	1.06
June	1.06
July	1.07
August	1.09
September	0.99
October	1.04
November	0.98
December	0.95



TABLE 1-E: ANNUAL TRANSACTIONS BY VEHICLE 2011-2012

Tollway Route	Passenger Vehicles		Commercial Vehicles		% CV	
	2011	2012	2011	2012	2011	2012
Jane Addams Memorial	152,736,239	147,485,627	18,493,846	19,476,188	10.8%	11.7%
Tri-State	308,635,040	294,934,707	49,086,535	49,395,590	13.7%	14.3%
Reagan Memorial	131,517,991	125,390,023	11,247,947	11,303,294	7.9%	8.3%
Veterans Memorial	150,305,754	143,870,062	10,804,328	11,924,840	6.7%	7.7%
Total	743,195,024	711,680,419	89,632,656	92,099,912	10.8%	11.5%

TABLE 1-F: I-PASS PARTICIPATION RATE* 2011-2012

Tollway Route	2011	2012	Change
Jane Addams Memorial	81.2%	83.6%	2.4%
Tri-State	81.7%	84.5%	1.3%
Reagan Memorial	86.3%	88.4%	2.1%
Veterans Memorial	89.2%	91.2%	2.0%
Total	83.9%	86.3%	2.4%

* Adjusted I-PASS participation rate as provided by the Illinois Tollway



TABLE 1-G: HISTORY OF TOLLWAY ADDITIONS BY MILEAGE 1959 — 2012

Year	Mainline Lane - Miles	Ramp Lane - Miles	Total Lane - Miles
1959	811	88	899
1960	812	88	900
1963	812	89	901
1966	822	92	914
1967	839	93	932
1970	839	94	933
1971	839	96	935
1972	840	97	937
1973	856	98	954
1974	1,154	109	1,263
1975	1,176	110	1,286
1976	1,200	110	1,310
1977	1,222	110	1,332
1979	1,235	110	1,345
1982	1,235	115	1,350
1983	1,235	115	1,350
1984	1,237	117	1,354
1986	1,237	118	1,355
1987	1,249	118	1,367
1988	1,249	119	1,368
1989	1,342	154	1,496
1990	1,342	156	1,498
1991	1,342	157	1,499
1992	1,354	159	1,513
1993	1,413	159	1,572
1994	1,417	164	1,581
1995	1,417	167	1,584
1996	1,427	169	1,596
1997	1,428	175	1,603
1998	1,444	179	1,623
1999	1,459	181	1,641
2000	1,467	183	1,649
2001	1,469	184	1,653
2002	1,470	184	1,654
2003	1,473	184	1,657
2004	1,477	185	1,662
2005	1,484	186	1,670
2006	1,501	186	1,687
2007	1,575	210	1,785
2008	1,599	267	1,866
2009	1,741	305	2,046
2010	1,741	305	2,046
2011	1,741	305	2,046
2012	1,743	305	2,048

Values taken from "Consulting Engineers Annual Report" by AECOM
Mileage for 2012 is estimated.



TABLE 1-H: HISTORY OF TOLLWAY ADDITIONS BY LOCATION 1960 — 2012

Year	Location	Mileage	Lane
1960	- Third Lane, between MP 40 & 41, NB TS	0.5	LM
	- Third Lane, vicinity MP 1, JA	0.5	LM
1963	- Willow Road, 2 Ramps, 2,200', TS	0.5	RLM
1966	- Third Lane, MP 0-5, SB TS	10.0	LM
	- I-80 Interchange Ramps, TS	3.0	RLM
1967	- Third Lane, MP 2.5-11, JA	17.0	LM
	- Lincoln Oasis, 4 Ramps, TS	1.0	RLM
1970	- Arlington Heights Ramps, 7100', JA	1.5	RLM
1971	- Joliet Road, Ramp Widening, TS	0.5	RLM
	- Willow Road Ramps, TS	1.5	RLM
1972	- Fourth Lane, MP 39-40, SB TS	1.0	LM
	- IL 47 Interchange Ramps, JA	0.5	RLM
1973	- Third Lane, MP 16-24, TS	16.0	LM
	- O'Hare East Ramps, TS	1.5	RLM
1974	- Third Lane, MP 44-49, TS	10.0	LM
	- Third Lane, MP 11-17, JA	12.0	LM
	- RM Tollway Extension, 69 Miles	276.0	LM
	- RM Tollway Extension Ramps	11.3	RLM
1975	- Third Lane, MP 5-16, TS	22.0	LM
	- Barrington Road Ramps, JA	1.0	RLM
1976	- Third Lane, MP 49-53, TS	8.0	LM
	- Third Lane, MP 62.5-70.5, TS	16.0	LM
1977	- Third Lane, MP 145-156, RM	22.0	LM
1979	- Third Lane, MP 70.5-77, TS	13.0	LM
1982	- US 51 Cloverleaf Interchange Ramps, RM	2.0	RLM
	- IL 59 Interchange, 2 Additional Ramps, RM	0.5	RLM
	- Hinsdale Oasis, 1 Additional Ramp, TS	0.5	RLM
	- Joliet Road, Extended & Widened Ramp, TS	1.5	RLM
1983	- Highland Avenue, 2 Additional Ramps, RM	0.5	RLM
	- Willow Road, Changed 2 Ramps, TS	--	--

(cont'd)



TABLE 1-H: HISTORY OF TOLLWAY ADDITIONS BY LOCATION 1960 — 2012

Year	Location	Mileage	Lane
1984	- Roselle Road, 2 Additional Ramps, JA	2.0	RLM
	- Fourth Lane, MP 41.5-42.5, NB TS	1.0	LM
	- Fourth Lane, MP 1.5-2.5, WB JA	1.0	LM
1986	- Naperville Road, 1 Additional Ramp, RM	0.5	RLM
1987	- East Riverside Boulevard Ramps, JA	0.5	RLM
	- Third Lane, MP 139-145, RM	12.0	LM
1988	- Orchard Road Ramps, RM	1.0	RLM
1989	- 95th Street, 2 Additional Ramps, TS	1.0	RLM
	- East Riverside Boulevard, 2 Additional Ramps, JA	1.0	RLM
	- IL 60 Interchange, 2 Additional Ramps, TS	1.0	RLM
	- VM Tollway, 17.5 Miles	93.0	LM
	- VM Tollway, 48 Ramps	32.0	RLM
1990	- Lake Cook Road, 2 Additional Ramps, TS	1.0	RLM
	- Randall Road, 2 Additional Ramps, JA	0.5	RLM
1991	- 159th Street, 4 Additional Ramps, TS	1.5	RLM
1992	- IL 59 Interchange, 4 Additional Ramps, JA	1.5	RLM
	- JA Tollway Widening, Barrington Road to Fox River	12.0	LM
	- Open access from Plaza 32 to River Road		
1993	- TS Tollway Widening, 95th Street to I-190	58.5	LM
	- Balmoral Avenue, 1 Additional Ramp, TS	0.5	RLM
1994	- 75th Street, 4 Additional Ramps, TS	1.7	RLM
	- VM Tollway Widening, Maple Avenue to Boughton Rd	4.0	LM
	- Winfield Road, 4 Additional Ramps, RM	1.6	RLM
	- Beverly Road, 2 Additional Ramps, JA	2.0	RLM
1995	- Lake Cook Road, 1 Additional Ramp, TS	0.3	RLM
	- Rockton Road, 2 Additional Ramps, JA	0.6	RLM
	- IL 137 Interchange, 2 Additional Ramps, TS	2.1	RLM
1996	- VM Tollway Widening, M.P. 22 - 28	10.1	LM
	- Arlington Heights Road Ramps, JA	1.5	RLM
	- Golf Road Ramp, TS	0.2	RLM
	- I-290 / 294 Interchange Ramp, TS	0.2	RLM

(cont'd)



TABLE 1-H: HISTORY OF TOLLWAY ADDITIONS BY LOCATION 1960 — 2012

Year	Location	Mileage	Lane	
1997	- Randall Road, 2 Additional Ramps, JA	1.5	RLM	
	- Orchard Road, 2 Additional Ramps, RM	1.2	RLM	
	- IL 137 Interchange, 2 Additional Ramps, TS	1.8	RLM	
	- JA Tollway, Auxiliary Lane, I-290 to Roselle Road	1.6	LM	
	- Barrington & Roselle Roads Interchange Plazas, JA	1.5	RLM	
1998	- RM Tollway Widening, Plaza 61 to Route 59	9.6	LM	
	- TS Tollway, Edens Spur/Plaza 24	2.2	LM	
	- JA Tollway, I-PASS at Plaza 9, River Bridge Widening	3.5	LM	
	- Peace Road Interchange, RM	1.1	RLM	
	- Route 20 Bypass, JA	0.5	RLM	
	- Willow Road Interchange, TS	1.2	RLM	
	- Golf Road Interchange, TS	0.7	RLM	
	- Ogden and 63rd Street, Ramp Widening, JA	0.2	RLM	
	1999	- Army Trail Road Plaza, VM	5.6	LM
		- I-90/I-290 Interchange and Plaza 15 Improvements, JA	0.6	LM
- I-90/I-290 Interchange and Plaza 15 Improvements, JA		0.8	RLM	
- Boughton Road Interchange and Plaza Improvements, VM		7.0	LM	
- Boughton Road Interchange and Plaza Improvements, VM		1.2	RLM	
- Additional Northbound Tri-State Lane open from Deerfield Road to Half Day Road, TS		2.7	LM	
2000	- Plaza 41/163rd Street, I-Pass only lanes and increased ramp tapers to 159th Street Interchange, TS Milepost 5.0 to 6.5	1.5	LM	
	- Aurora/Plaza 61 I-Pass Express Expansion, RM Milepost 117.6 to 118.2	0.6	LM	
	- Additional Tri-State southbound lanes from Half-Day Road to Edens Spur Split and additional southbound exit ramp length to Lake Cook Road, TS Milepost 52.9 to 56.4	3.5	LM	
2001	- Deerfield Road Northbound exit from Edens Spur and Northbound entry from Lake Cook Road, TS Milepost 52.9	0.8	RLM	
	- Grand Avenue Ramp Widening, TS Milepost 69.8	0.5	RLM	
	- Additional lane between Plaza 36 to 95th Street, TS Milepost 19.8 to 18.0	1.8	LM	
2002	- Additional I-PASS Express Lane EB at Aurora Plaza 61, EB Milepost 117.6 to 118.2, RM	0.6	LM	
	- Additional I-PASS Only Lane NB at Touhy Plaza 29, TS Milepost 41.8	0.4	LM	

(cont'd)



TABLE 1-H: HISTORY OF TOLLWAY ADDITIONS BY LOCATION 1960 — 2012

Year	Location	Mileage	Lane
2003	- Additional I-PASS Only Lanes WB at River Road Plaza 19, Milepost 0.6, JA	0.7	LM
	- Additional I-PASS Only Lanes WB at Devon Avenue Plaza 17, Milepost 1.7, JA	1.5	LM
	- Convert shoulder to increase I-PASS Only Lane taper at WB York Road Plaza 51, Milepost 138.2, RM	1.5	LM
2004	- Additional lane on ramp at Route 31 Plaza 11, Milepost 24.1, JA	0.2	RLM
	- Additional lane on ramp at Farnworth Avenue Plaza 59, Milepost 19.3, RM	1	RLM
	- Additional lane on southbound exit to southbound I-55, VM Milepost 12.3	0.5	LM
	- Additional lane in both directions at Elgin Plaza 9, Milepost 25.0, JA	1.6	LM
	- Additional lane northbound from Maple Avenue to Ogden Avenue, Milepost 18.3 to Milepost 19.5, VM	0.3	LM
	- Convert shoulder eastbound on both sides of York Road Plaza 51, Milepost 138.2, RM	1.6	LM
2005	- Additional lane in both directions at IL 59 to Washington Street, Milepost 123.3 to Milepost 126.7, RM	3.4	LM
	- Additional lane on ramp at WB Randall Road, Milepost 26.6, JA	0.4	RLM
2006	- Additional lane in both direction at Tri-State terminus to Halsted Street, Milepost 0 to Milepost 5.39, TS	10.8	LM
2007	- I-355 South Extension mainline added, VM	73.8	LM
	- I-355 South Extension ramps added, VM	21.1	RLM
	- IL 173 ramps added at Milepost 79.3, JA	3	RLM
2008	- Additional lane in both directions at Stearns School Road to IL 173, Milepost 70.8 to Milepost 75.7, TS	9.8	LM
	- Additional lane in Northbound at 75th Street to Ogden Avenue, Milepost 19.5 to Milepost 15.5, VN	4	LM
	- Additional lane in both directions at Washington Street to Finley Road, Milepost 126.6 to Milepost 132.0, RM	10.8	LM

(cont'd)



TABLE 1-H: HISTORY OF TOLLWAY ADDITIONS BY LOCATION 1960 — 2012

Year	Location	Mileage	Lane
2009	- Additional lane in SB direction at 75th Street to Ogden Ave Milepost 15.5 to 19.5, VM	4	LM
	- Additional lane in both directions at Finley Road to IL-83 Milepost 132.0 to 137.1, RM	10.2	LM
	- Additional lane in both directions at 163rd Street to 95th Street Milepost 6.0 to 17.6, TS	23.2	LM
	- Additional lane in both directions at Balmoral Avenue to Stearns School Road Milepost 40.0 to 70.8, TS	61.6	LM
	- Additional lane in both directions at Newburg Road to Rockton Road Milepost 61.4 to 75.5, JA	28.2	LM
	- Additional ramp at Irene Road, Milepost 58, JA	0.4	RLM
	- New interchange at Eola Road, Milepost 121.4, RM	2.7	RLM
2010	- Additional payment lane on Entrance Ramp from Southbound Farnsworth Avenue to Eastbound I-88 (Plaza 59), Milepost 119.2.	0.1	RLM
2011	- New NB exit ramp at I-294 and Balmoral Ave.	0.5	RLM
2012	- Additional lane in both directions at IL 56 to Orchard Road Milepost 113.3 to 114.3, RM	2	LM

NOTES :

- LM—Roadway Lane Miles
- RLM—Ramp Lane Miles
- JA—Jane Addams Memorial Tollway
- RM—Reagan Memorial Tollway
- VM—Veterans Memorial Tollway
- TS—Tri-State Tollway

Data for this table was taken from “Consulting Engineers Annual Report” by AECOM
Mileage for 2012 is estimated.



TABLE 1-I: SUMMARY OF TRAFFIC CHARACTERISTICS AT PLAZAS (Annual Transactions)

JANE ADDAMS MEMORIAL TOLLWAY

Plaza	Traffic			I-PASS Usage ¹			
	Total (000s)	PC%	CV%	Total (000s)	Total% ²	PC%	CV%
1	17,039	71.4%	28.6%	11,839	69.5%	66.6%	76.7%
2	2,687	90.1%	9.9%	2,335	86.9%	87.7%	79.5%
4	1,656	89.0%	11.0%	1,426	86.1%	86.9%	80.1%
5	6,812	76.3%	23.7%	5,375	78.9%	77.1%	84.6%
7	8,047	79.1%	20.9%	6,413	79.7%	78.2%	85.3%
8	2,662	90.9%	9.1%	2,342	88.0%	88.8%	79.7%
9	31,232	86.3%	13.7%	26,574	85.1%	85.0%	85.7%
10	3,203	95.2%	4.8%	2,799	87.4%	89.5%	44.7%
11	6,785	93.8%	6.2%	6,058	89.3%	90.2%	74.7%
12	3,860	96.0%	4.0%	3,432	88.9%	90.9%	41.8%
13	1,988	92.9%	7.1%	1,656	83.3%	84.4%	68.4%
14	3,020	95.2%	4.8%	2,735	90.6%	90.5%	92.7%
15	12,676	89.1%	10.9%	11,032	87.0%	86.8%	89.3%
16	4,281	92.9%	7.1%	3,759	87.8%	89.7%	63.4%
17	30,007	93.6%	6.4%	25,489	84.9%	84.8%	87.6%
18	7,018	91.0%	9.0%	6,446	91.9%	93.0%	80.2%
19	23,989	95.5%	4.5%	19,921	83.0%	83.0%	83.7%
Jane Addams Memorial Total	166,962	88.3%	11.7%	139,632	83.6%	83.9%	81.9%

TRI-STATE TOLLWAY

20	2,467	93.0%	7.0%	2,244	90.9%	92.7%	67.5%
21	23,494	80.7%	19.3%	18,975	80.8%	79.2%	87.4%
22	3,670	94.5%	5.5%	3,286	89.5%	91.8%	50.2%
23	3,629	94.9%	5.1%	3,191	87.9%	90.4%	41.8%
24	19,128	91.6%	8.4%	15,708	82.1%	82.2%	81.0%
26	5,649	96.1%	3.9%	5,114	90.5%	90.4%	92.9%
27	5,624	95.3%	4.7%	5,120	91.0%	91.0%	91.9%
28	5,763	97.2%	2.8%	5,204	90.3%	90.3%	90.6%
29	31,786	91.0%	9.0%	27,685	87.1%	86.8%	90.4%
30	1,883	93.6%	6.4%	1,790	95.0%	95.1%	94.2%
31	7,844	98.2%	1.8%	6,816	86.9%	86.8%	93.1%
32	6,169	97.1%	2.9%	5,321	86.3%	86.1%	90.8%
33	33,723	90.3%	9.7%	29,611	87.8%	87.5%	90.2%
34	2,041	63.4%	36.6%	1,885	92.3%	92.2%	92.7%
35	47,305	83.2%	16.8%	40,899	86.5%	86.0%	88.9%
36	24,101	83.2%	16.8%	20,648	85.7%	85.0%	89.0%
37	20,572	84.7%	15.3%	17,755	86.3%	85.3%	92.0%
38	4,849	82.4%	17.6%	3,993	82.4%	82.9%	79.8%
39	23,851	83.0%	17.0%	20,417	85.6%	85.0%	88.7%
40	3,117	83.4%	16.6%	2,680	86.0%	84.7%	92.3%
41	35,735	78.1%	21.9%	29,534	82.6%	81.0%	88.4%
43	12,323	76.5%	23.5%	8,975	72.8%	72.8%	72.8%
45	11,999	76.8%	23.2%	8,779	73.2%	73.2%	73.0%
47	7,603	91.5%	8.5%	5,325	70.0%	68.2%	90.1%
Tri-State Total	344,330	85.7%	14.3%	290,954	84.5%	84.2%	86.6%

¹ Adjusted I-PASS percentage provided by Illinois Tollway

² Percent of total traffic

(cont'd)



TABLE 1-I: SUMMARY OF TRAFFIC CHARACTERISTICS AT PLAZAS (Annual Transactions)

REAGAN MEMORIAL TOLLWAY

Plaza	Traffic			I-PASS Usage ¹			
	Total (000s)	PC%	CV%	Total (000s)	Total% ²	PC%	CV%
51	29,467	94.1%	5.9%	25,943	88.0%	87.9%	90.9%
52	28,293	93.6%	6.4%	25,116	88.8%	88.6%	91.4%
53	2,979	98.1%	1.9%	2,777	93.2%	93.2%	93.2%
54	2,866	97.4%	2.6%	2,540	88.6%	88.6%	91.8%
55	1,262	98.5%	1.5%	1,156	91.6%	91.6%	93.9%
56	5,523	98.1%	1.9%	5,144	93.1%	93.7%	62.7%
57	3,987	97.9%	2.1%	3,677	92.2%	92.2%	94.4%
58	2,765	97.8%	2.2%	2,575	93.1%	93.2%	91.6%
59	9,805	91.4%	8.6%	8,467	86.4%	87.6%	73.1%
60	3,154	95.2%	4.8%	3,030	96.1%	96.1%	95.5%
61	27,737	90.0%	10.0%	24,765	89.3%	89.1%	90.7%
63	1,026	90.7%	9.3%	902	87.9%	89.4%	73.5%
64	1,399	86.0%	14.0%	1,249	89.3%	90.6%	81.5%
65	3,201	88.1%	11.9%	2,865	89.5%	88.8%	94.6%
66	6,359	75.7%	24.3%	5,202	81.8%	79.5%	89.0%
67	1,767	95.5%	4.5%	1,556	88.1%	87.8%	94.5%
69	5,104	74.5%	25.5%	3,927	76.9%	73.7%	86.4%
Reagan Memorial Total	136,693	91.7%	8.3%	120,891	88.4%	88.4%	88.5%

VETERANS MEMORIAL TOLLWAY

73	40,510	92.4%	7.6%	36,769	90.8%	90.8%	90.3%
75	9,927	87.7%	12.3%	9,143	92.1%	91.9%	93.5%
77	5,526	97.2%	2.8%	5,111	92.5%	92.5%	93.3%
79	6,174	97.4%	2.6%	5,665	91.8%	91.7%	94.1%
81	1,602	96.3%	3.7%	1,475	92.0%	92.0%	93.0%
83	4,498	96.7%	3.3%	4,245	94.4%	94.4%	94.9%
85	6,239	98.1%	1.9%	5,888	94.4%	94.4%	93.2%
87	5,923	97.6%	2.4%	5,527	93.3%	93.3%	93.2%
89	42,195	90.1%	9.9%	38,032	90.1%	90.1%	90.6%
90	4,519	97.4%	2.6%	3,966	87.8%	87.7%	92.5%
93	2,295	92.7%	7.3%	2,176	94.8%	94.8%	95.5%
95	2,890	95.9%	4.1%	2,680	92.7%	92.7%	92.8%
97	4,723	97.0%	3.0%	4,443	94.1%	94.0%	94.4%
99	17,428	88.0%	12.0%	15,790	90.6%	90.5%	91.4%
101	1,346	96.5%	3.5%	1,179	87.6%	87.5%	91.0%
Veterans Memorial Total	155,795	92.3%	7.7%	142,088	91.2%	91.2%	91.3%
Tollway Total	803,780	88.5%	11.5%	693,564	86.3%	86.3%	86.4%

¹ Adjusted I-PASS percentage provided by Illinois Tollway

² Percent of total traffic

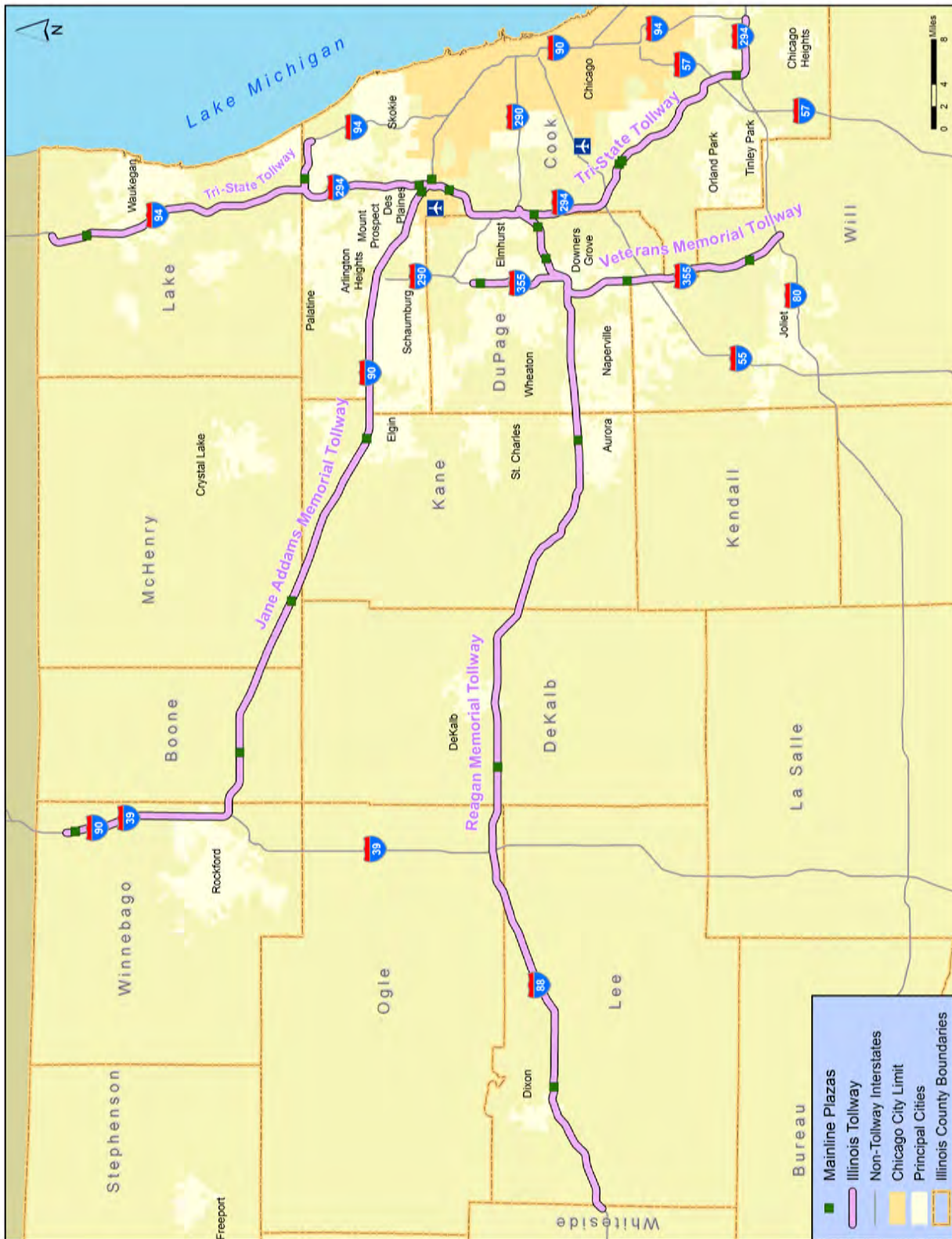

FIGURE 1-A: THE ILLINOIS TOLLWAY SYSTEM 2012



FIGURE 1-B: AVERAGE DAILY TRAFFIC 2012



FIGURE 1-C: ANNUAL AVERAGE PERCENTAGE CHANGE IN DAILY TRAFFIC VOLUMES 2000-2012

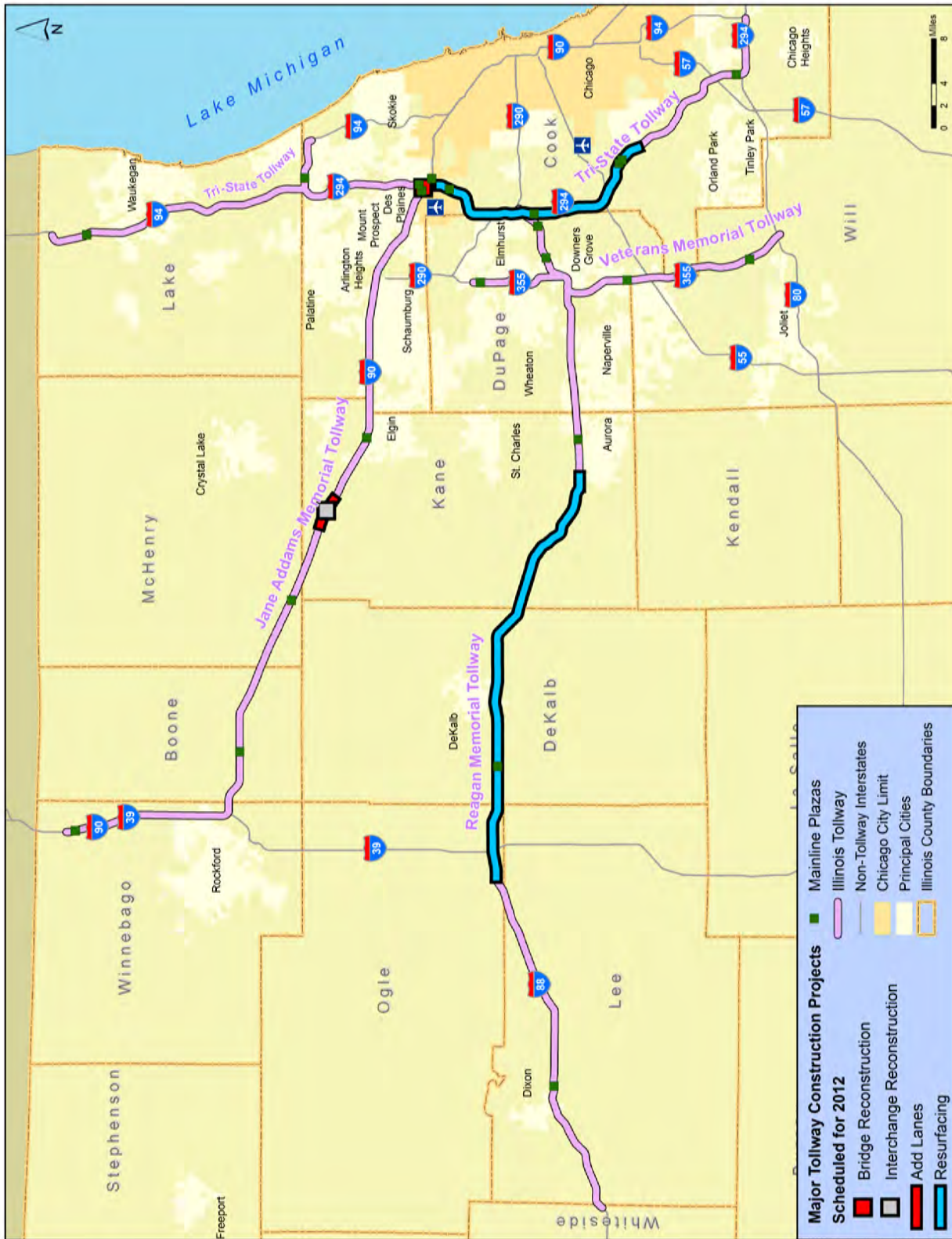

FIGURE 1-D: MAJOR TOLLWAY CONSTRUCTION PROJECTS DURING 2012

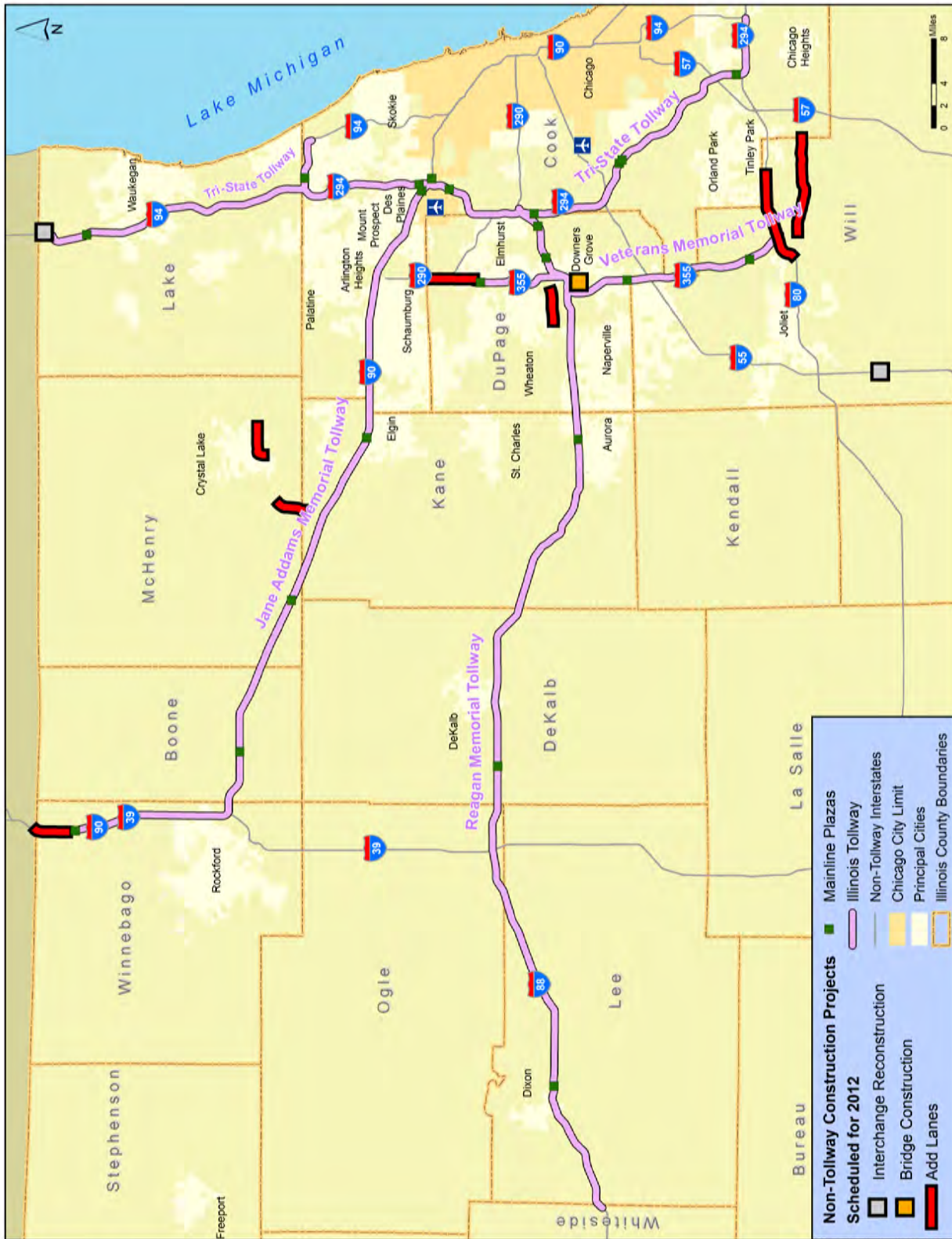

FIGURE 1-E: MAJOR OFF TOLLWAY CONSTRUCTION PROJECTS DURING 2012

Section 2 Tab





SECTION 2

Jane Addams Memorial Tollway

TABULATIONS TABLE

	PAGE
2-A Average Daily Traffic Volumes Between Interchanges 1980 – 2012 (Westbound)	2-4
2-B Average Daily Vehicle Miles Traveled Between Interchanges 1980 – 2012 (Westbound)	2-5
2-C Average Daily Traffic Volumes Between Interchanges 1980 – 2012 (Eastbound)	2-6
2-D Average Daily Vehicle Miles Traveled Between Interchanges 1980 – 2012 (Eastbound)	2-7
2-E General Statistics for Mainline Plazas	2-8
2-F Indexed Monthly Variation by Mainline Plaza	2-10
2-G Indexed Daily Variation by Mainline Plaza	2-10
2-H Annual Total Transactions by Toll Plaza	2-11
2-I Average Daily Traffic Data	2-12

ILLUSTRATIONS FIGURE

	PAGE
2-A Mainline Plaza Highest Hourly Volume Plaza 1 EB	2-13
2-B Mainline Plaza Highest Hourly Volume Plaza 1 WB	2-13
2-C Mainline Plaza Highest Hourly Volume Plaza 5 WB	2-13
2-D Mainline Plaza Highest Hourly Volume Plaza 7 EB	2-13
2-E Mainline Plaza Highest Hourly Volume Plaza 9 EB	2-14
2-F Mainline Plaza Highest Hourly Volume Plaza 9 WB	2-14
2-G Mainline Plaza Highest Hourly Volume Plaza 17 WB	2-14
2-H Mainline Plaza Highest Hourly Volume Plaza 19 EB	2-14
2-I Average Daily Traffic Trends Plaza 1 South Beloit	2-15
2-J Average Daily Traffic Trends Plaza 2 East Riverside Boulevard	2-15
2-K Average Daily Traffic Trends Plaza 3 South Rockford	2-15
2-L Average Daily Traffic Trends Plaza 4 Illinois 173	2-16



SECTION 2 Jane Addams Memorial Tollway

ILLUSTRATIONS (CONTINUED) FIGURE

PAGE

2-M	Average Daily Traffic Trends Plaza 5 Belvidere	2-16
2-N	Average Daily Traffic Trends Plaza 7 Marengo-Hampshire	2-16
2-O	Average Daily Traffic Trends Plaza 8 Randall Road	2-17
2-P	Average Daily Traffic Trends Plaza 9 Elgin	2-17
2-Q	Average Daily Traffic Trends Plaza 10 Barrington Road	2-17
2-R	Average Daily Traffic Trends Plaza 11 Illinois 31	2-18
2-S	Average Daily Traffic Trends Plaza 12 Roselle Road	2-18
2-T	Average Daily Traffic Trends Plaza 13 Illinois 25	2-18
2-U	Average Daily Traffic Trends Plaza 14 Illinois 59	2-19
2-V	Average Daily Traffic Trends Plaza 15 I-290, Illinois 53	2-19
2-W	Average Daily Traffic Trends Plaza 16 Beverly Road	2-19
2-X	Average Daily Traffic Trends Plaza 17 Devon Avenue	2-20
2-Y	Average Daily Traffic Trends Plaza 18 Arlington Heights Road	2-20
2-Z	Average Daily Traffic Trends Plaza 19 River Road	2-20



This Page Is Intentionally Left Blank



TABLE 2-A: AVERAGE DAILY TRAFFIC VOLUMES BETWEEN INTERCHANGES 1980-2012 (WESTBOUND)

Location	Mile Post	Miles Btwn. Int.	ADT 1980	Average Annual Percent Change	ADT 1990	Average Annual Percent Change	ADT 2000	Average Annual Percent Change	ADT 2010	Average Annual Percent Change	ADT 2012
Kennedy Expressway	78.6										
		0.8	39,270	4.0	58,040	1.4	66,420	-0.5	62,870	-2.5	59,720
Tri-State Interchange	77.8										
		0.5	51,310	3.7	73,590	1.5	85,520	-0.2	83,420	-3.5	77,640
Devon Ave.	77.3										
Plaza 17	77.3	1.2	56,160	3.7	80,790	1.4	93,190	-0.4	89,150	-4.1	81,990
Lee St.	76.1										
		1.7	52,730	3.5	74,740	1.6	87,610	-0.5	83,390	-4.3	76,330
Des Plaines Oasis	74.4										
		0.9	52,730	3.5	74,740	1.6	87,610	-0.5	83,390	-4.3	76,330
Elmhurst Rd.	73.5										
		2.8	40,790	3.8	59,510	1.8	70,910	-0.1	70,530	-5.0	63,680
Arlington Heights Rd. (PL18)	70.7										
		2.5	34,440	3.8	50,010	3.9	73,120	-0.2	71,440	-5.8	63,340
IL53/I-290	68.2										
		2.7	29,360	5.9	51,970	3.2	71,530	1.2	80,270	-4.6	73,120
Roselle Rd. (PL12)	65.5										
		3.3	29,360	3.9	43,100	3.6	61,490	1.2	69,090	-4.8	62,570
Barrington Rd. (PL10)	62.2										
		2.5	17,070	4.5	26,580	6.4	49,640	1.8	59,410	-4.8	53,820
IL 59 (PL14)	59.7										
		1.6	18,470	4.9	29,780	4.9	48,160	2.4	61,340	-4.1	56,400
Beverly Rd. (PL16)	58.1										
		1.8	18,470	4.9	29,780	3.8	43,120	2.7	56,220	-3.9	51,900
IL25 (PL13)	56.3										
		1.7	16,330	4.9	26,350	4.7	41,520	2.7	54,370	-3.5	50,580
IL31 (PL11)	54.6										
Plaza 9	53.8	2.5	11,340	4.2	17,090	6.6	32,270	3.5	45,660	-3.4	42,650
Randall Rd. (PL8)	52.1										
		5.7	11,340	2.9	15,020	5.6	25,780	2.4	32,800	-3.3	30,660
IL47	46.4										
		4.5	10,130	2.0	12,380	5.4	20,870	1.8	25,040	-3.2	23,480
Marengo Rd. (US20)	41.9										
		16.6	9,340	2.5	12,000	4.9	19,320	1.9	23,390	-2.6	22,210
Genoa Rd.	25.3										
		1.1	8,490	2.5	10,860	4.1	16,300	1.8	19,420	-2.1	18,630
Belvidere Oasis	24.2										
Plaza 5	23.3	3.4	8,490	2.5	10,860	4.1	16,300	1.8	19,420	-2.1	18,630
Irene Road	20.8										
		3.4	8,490	2.5	10,860	4.1	16,300	1.7	19,200	-2.0	18,440
I-39/US20 (Cherry Valley)	17.4										
		2.2	9,160	4.6	14,330	3.9	21,010	3.1	28,380	0.2	28,470
US Business 20	15.2										
		2.9	8,270	5.2	13,750	4.8	22,060	1.7	26,060	0.7	26,430
E. Riverside Blvd. (PL2)	12.3										
		3.4	8,270	4.8	13,180	4.7	20,840	1.5	24,300	0.9	24,740
IL 173 (PL4)	8.9										
Plaza 1	3.5	6.2	8,270	4.8	13,180	4.7	20,840	0.9	22,800	0.4	23,000
West Terminus	2.7										
Grand Total		75.9	558,080	4.0	822,490	3.1	1,111,730	0.9	1,211,360	-0.6	1,124,760



TABLE 2-B: AVERAGE DAILY VEHICLE MILES TRAVELED BETWEEN INTERCHANGES 1980-2012 (WESTBOUND)

Location	Mile Post	Miles Btwn. Int.	Daily Vehicle Miles				
			1980	1990	2000	2010	2012
Kennedy Expressway	78.6	0.8	31,416	46,432	53,136	50,296	47,776
Tri-State Interchange	77.8	0.5	25,655	36,795	42,760	41,710	38,820
Devon Ave. Plaza 17	77.3	1.2	67,392	96,948	111,828	106,980	98,388
Lee St.	76.1	1.7	89,641	127,058	148,937	141,763	129,761
Des Plaines Oasis	74.4	0.9	47,457	67,266	78,849	75,051	68,697
Elmhurst Rd.	73.5	2.8	114,212	166,628	198,548	197,484	178,304
Arlington Heights Rd. (PL18)	70.7	2.5	86,100	125,025	182,800	178,600	158,350
IL53/I-290	68.2	2.7	79,272	140,319	193,131	216,729	197,424
Roselle Rd. (PL12)	65.5	3.3	96,888	142,230	202,917	227,997	206,481
Barrington Rd. (PL10)	62.2	2.5	42,675	66,450	124,100	148,525	134,550
IL 59 (PL14)	59.7	1.6	29,552	47,648	77,056	98,144	90,240
Beverly Rd. (PL16)	58.1	1.8	33,246	53,604	77,616	101,196	93,420
IL25 (PL13)	56.3	1.7	27,761	44,795	70,584	92,429	85,986
IL31 (PL11)	54.6	2.5	28,350	42,725	80,675	114,150	106,625
Plaza 9	53.8	5.7	64,638	85,614	146,946	186,960	174,762
Randall Rd. (PL8)	52.1	4.5	45,585	55,710	93,915	112,680	105,660
IL47	46.4	16.6	155,044	199,200	320,712	388,274	368,686
Marengo Rd. (US20)	41.9	1.1	9,339	11,946	17,930	21,362	20,493
Genoa Rd.	25.3	3.4	28,866	36,924	55,420	66,028	63,342
Belvidere Oasis	24.2	3.4	28,866	36,924	55,420	65,280	62,696
Plaza 5	23.3	2.2	20,152	31,526	46,222	62,436	62,634
Irene Road	20.8	2.9	23,983	39,875	63,974	75,574	76,647
I-39/US20 (Cherry Valley)	17.4	3.4	28,118	44,812	70,856	82,620	84,116
US Business 20	15.2	8.9	51,274	81,716	129,208	141,360	142,600
E. Riverside Blvd. (PL2)	12.3	6.2	51,274	81,716	129,208	141,360	142,600
IL 173 (PL4)	8.9	2.7					
Plaza 1	3.5						
West Terminus	2.7						
Grand Total		75.9	1,255,482	1,828,170	2,643,540	2,993,628	2,796,458



TABLE 2-C: AVERAGE DAILY TRAFFIC VOLUMES BETWEEN INTERCHANGES 1980-2012 (EASTBOUND)

Location	Mile Post	Miles Btwn. Int.	ADT 1980	Average Annual Percent Change	ADT 1990	Average Annual Percent Change	ADT 2000	Average Annual Percent Change	ADT 2010	Average Annual Percent Change	ADT 2012
Kennedy Expressway	78.6										
Plaza 19	78.5	0.8	48,260	3.3	67,020	1.3	76,300	-0.9	69,600	-2.9	65,560
Tri-State Interchange	77.8										
		0.5	55,550	3.4	77,830	2.5	99,340	-1.7	83,980	-2.2	80,310
Devon Ave.	77.3										
	77.3	1.2	55,550	3.4	77,830	2.5	99,340	-1.7	83,980	-2.2	80,310
Lee St.	76.1										
		1.7	52,110	3.3	71,920	2.4	91,250	-1.6	77,640	-2.3	74,180
Des Plaines Oasis	74.4										
		0.9	52,110	3.3	71,920	2.4	91,250	-1.6	77,640	-2.3	74,180
Elmhurst Rd.	73.5										
		2.8	40,200	3.6	57,210	2.3	72,090	-0.5	68,390	-2.3	65,240
Arlington Heights Rd. (PL18)	70.7										
		2.5	33,800	3.6	48,150	4.3	73,360	-0.4	70,680	-3.2	66,230
IL53/I-290 (PL 15)	68.2										
		2.7	29,110	5.8	50,930	4.2	77,040	0.7	82,430	-2.3	78,620
Roselle Rd.	65.5										
		3.3	29,110	3.9	42,540	4.8	68,280	0.4	70,850	-2.5	67,420
Barrington Rd.	62.2										
		2.5	16,770	4.6	26,250	7.5	54,030	0.9	59,150	-2.6	56,100
IL59 (PL14)	59.7										
		1.6	18,090	5.0	29,480	5.5	50,150	1.9	60,830	-3.6	56,580
Beverly Rd.	58.1										
		1.8	18,090	5.0	29,480	4.3	44,840	2.1	55,370	-3.7	51,300
IL25 (PL13)	56.3										
		1.7	15,860	5.1	26,180	5.1	43,030	2.3	54,220	-3.3	50,750
IL31 (PL11)	54.6										
Plaza 9	53.8	2.5	11,660	4.1	17,360	6.6	32,790	3.3	45,350	-3.0	42,690
Randall Rd. (PL8)	52.1										
		5.7	11,660	2.7	15,290	5.5	26,180	2.5	33,500	-3.1	31,450
IL47	46.4										
		4.5	10,360	2.0	12,620	5.1	20,770	2.5	26,520	-3.1	24,910
Marengo Rd. (US 20)	41.9										
Plaza 7		16.6	9,290	2.6	12,000	4.7	19,010	2.0	23,220	-2.7	21,990
Genoa Rd.	25.3										
		1.1	8,720	2.3	10,990	4.1	16,430	2.2	20,470	-2.3	19,520
Belvidere Oasis	24.2										
		3.4	8,720	2.3	10,990	4.1	16,430	2.2	20,470	-2.3	19,520
Irene Road	20.8										
		3.4	8,720	2.3	10,990	4.1	16,430	2.2	20,470	-2.3	19,520
I-39/US20 (Cherry Valley)	17.4										
		2.2	9,490	4.6	14,920	3.5	20,960	2.9	27,820	0.2	27,940
US Business 20	15.2										
		2.9	8,430	5.2	14,000	4.3	21,370	2.2	26,690	0.7	27,040
E. Riverside Blvd (PL2)	12.3										
		3.4	8,430	4.8	13,450	4.1	20,100	2.1	24,680	0.7	25,050
IL 173 (PL4)	8.9										
Plaza 1	3.5	6.2	8,430	4.8	13,450	4.1	20,100	1.5	23,420	0.3	23,560
North Terminus	2.7										
Grand Total		75.9	568,520	3.8	822,800	3.6	1,170,870	0.3	1,207,370	-2.4	1,149,970



TABLE 2-D: AVERAGE DAILY VEHICLE MILES TRAVELED BETWEEN INTERCHANGES 1980-2012 (EASTBOUND)

Location	Mile Post	Miles Btwn. Int.	Daily Vehicle Miles				
			1980	1990	2000	2010	2012
Kennedy Expressway	78.6						
Plaza 19	78.5	0.8	38,608	53,616	61,040	55,680	52,448
Tri-State Interchange	77.8						
		0.5	27,775	38,915	49,670	41,990	40,155
Devon Ave.	77.3						
	77.3	1.2	66,660	93,396	119,208	100,776	96,372
Lee St.	76.1						
		1.7	88,587	122,264	155,125	131,988	126,106
Des Plaines Oasis	74.4						
		0.9	46,899	64,728	82,125	69,876	66,762
Elmhurst Rd.	73.5						
		2.8	112,560	160,188	201,852	191,492	182,672
Arlington Heights Rd. (PL18)	70.7						
		2.5	84,500	120,375	183,400	176,700	165,575
IL53/I-290 (PL 15)	68.2						
		2.7	78,597	137,511	208,008	222,561	212,274
Roselle Rd.	65.5						
		3.3	96,063	140,382	225,324	233,805	222,486
Barrington Rd.	62.2						
		2.5	41,925	65,625	135,075	147,875	140,250
IL59 (PL14)	59.7						
		1.6	28,944	47,168	80,240	97,328	90,528
Beverly Rd.	58.1						
		1.8	32,562	53,064	80,712	99,666	92,340
IL25 (PL13)	56.3						
		1.7	26,962	44,506	73,151	92,174	86,275
IL31 (PL11)	54.6						
Plaza 9	53.8	2.5	29,150	43,400	81,975	113,375	106,725
Randall Rd. (PL8)	52.1						
		5.7	66,462	87,153	149,226	190,950	179,265
IL47	46.4						
		4.5	46,620	56,790	93,465	119,340	112,095
Marengo Rd. (US 20)	41.9						
Plaza 7		16.6	154,214	199,200	315,566	385,452	365,034
Genoa Rd.	25.3						
		1.1	9,592	12,089	18,073	22,517	21,472
Belvidere Oasis	24.2						
		3.4	29,648	37,366	55,862	69,598	66,368
Irene Road	20.8						
		3.4	29,648	37,366	55,862	69,598	66,368
I-39/US20 (Cherry Valley)	17.4						
		2.2	20,878	32,824	46,112	61,204	61,468
US Business 20	15.2						
		2.9	24,447	40,600	61,973	77,401	78,416
E. Riverside Blvd (PL2)	12.3						
		3.4	28,662	45,730	68,340	83,912	85,170
IL 173 (PL4)	8.9						
Plaza 1	3.5	6.2	52,266	83,390	124,620	145,204	146,072
North Terminus	2.7						
Grand Total		75.9	1,262,229	1,817,646	2,726,004	3,000,462	2,862,696



**TABLE 2-E: GENERAL STATISTICS FOR MAINLINE PLAZAS
(Vehicles/Hour)**

Mainline Plaza	Dir.	30th HV	Period	Mean	Med.	Max.	Min.	Std. Dev.	85th %
1 South Beloit	EB	2,985	AM Peak	1,231	1,127	1,622	673	229	1,486
			PM Peak	1,570	1,557	2,246	487	207	1,780
			OFF Peak	1,159	1,200	2,356	229	361	1,505
			Weekend	1,012	956	3,203	66	682	1,780
			Holidays	1,070	907	3,153	66	815	1,980
	WB	2,754	AM Peak	963	961	1,372	519	185	1,174
			PM Peak	1,632	1,611	2,276	724	207	1,816
			OFF Peak	1,121	1,114	2,333	287	353	1,482
			Weekend	1,004	950	3,162	76	660	1,750
			Holidays	1,011	842	3,251	45	766	1,774
5 Belvidere	WB	2,140	AM Peak	816	823	1,165	463	159	987
			PM Peak	1,191	1,177	1,736	620	155	1,339
			OFF Peak	883	897	1,919	255	280	1,155
			Weekend	839	835	2,855	68	526	1,417
			Holidays	833	747	2,641	51	605	1,401
7 Marengo-Hampshire	EB	2,723	AM Peak	1,391	1,400	1,557	918	87	1,473
			PM Peak	1,258	1,238	2,080	565	167	1,424
			OFF Peak	1,042	1,071	1,979	277	263	1,278
			Weekend	963	985	2,963	76	613	1,586
			Holidays	1,006	974	2,959	81	713	1,673
9 Elgin	EB	4,277	AM Peak	4,003	4,048	4,442	2,451	243	4,208
			PM Peak	2,435	2,435	3,327	1,574	212	2,644
			OFF Peak	2,092	2,142	3,568	587	626	2,703
			Weekend	1,733	1,861	4,300	146	1,040	2,827
			Holidays	1,746	1,775	3,888	134	1,090	2,932
	WB	4,583	AM Peak	1,886	1,853	2,395	1,203	255	2,169
			PM Peak	4,187	4,219	4,652	2,897	218	4,371
			OFF Peak	2,140	2,014	4,211	722	695	2,935
			Weekend	1,732	1,777	4,858	176	1,049	2,741
			Holidays	1,674	1,608	4,867	103	1,131	2,725

(cont'd)



**TABLE 2-E: GENERAL STATISTICS FOR MAINLINE PLAZAS
(Vehicles/Hour)**

Mainline Plaza	Dir.	30th HV	Period	Mean	Med.	Max.	Min.	Std. Dev.	85th %
17 Devon Avenue	WB	6,648	AM Peak	5,358	5,132	6,650	3,306	759	6,283
			PM Peak	6,176	6,202	6,797	3,952	336	6,488
			OFF Peak	4,277	4,325	6,831	1,912	1,006	5,428
			Weekend	3,239	3,375	6,773	409	1,664	4,940
			Holidays	2,935	3,036	6,624	412	1,660	4,677
19 River Road	EB	4,670	AM Peak	4,022	4,053	4,741	2,862	327	4,365
			PM Peak	3,403	3,421	4,329	1,360	434	3,903
			OFF Peak	3,447	3,443	4,858	1,620	541	4,036
			Weekend	2,742	3,206	5,065	295	1,381	4,117
			Holidays	2,542	2,866	5,157	198	1,380	3,985

AM Peak = Weekday 6:00 AM To 8:00 AM Except Fridays
 PM Peak = Weekday 4:00 PM To 6:00 PM Except Fridays
 OFF Peak = Weekday 5:00 AM To 10:00 PM Except AM and PM Peak Periods
 Weekend = Fridays, Saturdays, and Sundays
 Holidays = See Page 1-4 for list of Holidays.



TABLE 2-F: INDEXED MONTHLY VARIATION BY MAINLINE PLAZA

Month	South Beloit	Belvidere	Marengo	Elgin	Devon Avenue	River Road
January	0.80	0.80	0.83	0.86	0.93	0.92
February	0.85	0.86	0.88	0.92	0.99	0.98
March	0.92	0.93	0.93	0.96	0.98	1.01
April	0.96	0.97	0.98	0.99	0.95	1.02
May	1.03	1.06	1.04	1.04	0.97	1.01
June	1.16	1.19	1.13	1.10	1.02	1.04
July	1.22	1.21	1.19	1.09	1.04	1.03
August	1.20	1.21	1.18	1.11	1.08	1.04
September	1.03	1.01	1.03	1.01	1.03	1.00
October	0.99	0.95	0.97	1.00	1.04	0.99
November	0.95	0.92	0.94	0.98	1.01	0.98
December	0.88	0.89	0.89	0.93	0.97	0.97

TABLE 2-G: INDEXED DAILY VARIATION BY MAINLINE PLAZA

Month	Day	South Beloit	Belvidere	Marengo	Elgin	Devon Avenue	River Road
August	Monday	1.16	1.17	1.14	1.09	1.07	1.01
	Tuesday	1.13	1.14	1.14	1.08	1.06	1.04
	Wednesday	1.14	1.15	1.15	1.08	1.07	1.04
	Thursday	1.17	1.19	1.15	1.08	1.06	1.03
	Friday	1.21	1.27	1.15	1.11	1.07	1.05
	Saturday	1.21	1.21	1.20	1.12	1.06	1.02
	Sunday	1.30	1.21	1.32	1.18	1.08	1.05
December	Monday	0.83	0.87	0.85	0.92	0.96	0.99
	Tuesday	0.90	0.93	0.95	0.97	0.94	0.97
	Wednesday	1.01	0.99	0.99	0.99	1.00	0.99
	Thursday	0.85	0.86	0.87	0.93	0.97	0.96
	Friday	0.89	0.83	0.92	0.94	1.00	0.99
	Saturday	0.95	0.92	0.95	0.96	1.00	0.96
	Sunday	0.80	0.87	0.74	0.87	0.96	0.92

Table 2-G includes Monthly Variation



TABLE 2-H: ANNUAL TOTAL TRANSACTIONS BY TOLL PLAZA

Plaza	Plaza Code*	2011	2012	Percentage Change
1 South Beloit	M	17,108,319	17,039,465	-0.4%
2 E. Riverside Boulevard	R	2,833,739	2,686,977	-5.2%
4 Illinois 173	R	1,669,748	1,655,635	-0.8%
5 Belvidere	M1	6,863,166	6,812,234	-0.7%
7 Marengo-Hampshire	M1	8,053,802	8,047,102	-0.1%
8 Randall Road	R	2,827,268	2,661,948	-5.8%
9 Elgin	M	31,586,836	31,231,707	-1.1%
10 Barrington Road	R	3,352,991	3,202,748	-4.5%
11 Illinois 31	R	6,846,674	6,785,346	-0.9%
12 Roselle Road	R	4,217,589	3,859,533	-8.5%
13 Illinois 25	R	2,110,301	1,988,380	-5.8%
14 Illinois 59	R	3,222,248	3,019,768	-6.3%
15 I-290, Illinois 53	R	12,728,998	12,676,268	-0.4%
16 Beverly Road	R	4,321,469	4,280,500	-0.9%
17 Devon Avenue	M1	31,703,310	30,006,967	-5.4%
18 Arlington Heights Road	R	7,610,318	7,017,808	-7.8%
19 River Road	M1	24,173,309	23,989,429	-0.8%
Jane Addams Total		171,230,085	166,961,815	-2.5%

* M=Mainline / R=Ramp / A=Attended Ramp Plaza / E=Electronic Toll Collection Only Ramp
1=Toll Collected in One Direction Only



TABLE 2-I: AVERAGE DAILY TRAFFIC DATA

Year	Average Daily Total			Average Trip
	Vehicles	Vehicle Miles	Transactions	Length (Miles)
1959	10,937	513,839	16,852	46.98
1960	21,417	720,403	29,637	33.64
1961	30,379	893,740	41,601	29.42
1962	35,337	978,261	48,297	27.68
1963	36,384	1,060,625	52,810	29.15
1964	38,704	1,130,304	55,528	29.20
1965	44,034	1,239,411	62,735	28.15
1966	49,418	1,348,751	68,336	27.29
1967	53,402	1,397,288	73,035	26.17
1968	59,443	1,535,620	81,811	25.83
1969	66,752	1,637,427	118,986	24.53
1970	75,218	1,757,108	138,024	23.36
1971	81,517	1,867,136	146,198	22.90
1972	87,416	1,929,076	156,403	22.07
1973	102,262	2,070,220	175,930	20.24
1974	101,814	2,001,520	171,108	19.66
1975	110,185	2,141,250	184,352	19.43
1976	118,923	2,301,465	199,710	19.35
1977	126,388	2,435,431	212,020	19.27
1978	134,830	2,502,453	220,878	18.56
1979	139,786	2,606,029	228,180	18.64
1980	140,928	2,536,515	227,729	18.00
1981	143,284	2,619,176	230,868	18.28
1982	146,090	2,634,806	234,034	18.04
1983	152,561	2,770,933	247,674	18.16
1984	144,728	2,666,506	238,152	18.42
1985	164,771	2,861,454	257,366	17.37
1986	175,655	3,134,635	281,112	17.85
1987	191,936	3,392,046	307,469	17.67
1988	205,510	3,558,352	329,391	17.31
1989	213,965	3,643,665	336,575	17.03
1990	225,655	3,669,541	347,884	16.26
1991	222,370	3,673,993	365,120	16.52
1992	234,074	4,081,095	375,921	17.44
1993	253,304	4,279,655	389,127	16.90
1994	260,359	4,533,228	412,288	17.41
1995	269,680	4,774,725	432,373	17.71
1996	275,020	4,912,102	439,095	17.86
1997	282,900	5,105,618	454,622	18.05
1998	284,860	5,125,064	480,098	17.99
1999	294,050	5,567,182	512,810	18.93
2000	294,850	5,402,466	507,784	18.32
2001	309,100	5,828,988	541,479	18.86
2002	296,870	5,773,234	532,658	19.45
2003	304,510	5,857,387	541,345	19.24
2004	323,450	6,158,090	556,501	19.04
2005	312,300	6,002,609	530,257	19.22
2006	312,990	5,918,699	478,556	18.91
2007	318,420	6,120,967	492,225	19.22
2008	313,550	5,853,800	479,141	18.67
2009	308,050	5,744,595	473,015	18.65
2010	335,170	5,994,090	484,642	17.88
2011	317,070	5,813,945	470,237	18.34
2012	308,770	5,659,154	456,180	18.33



FIGURE 2-B

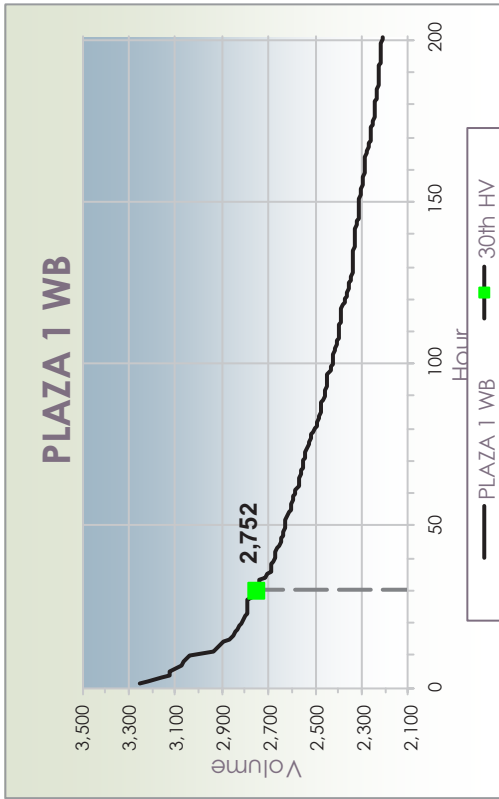

FIGURE 2-D

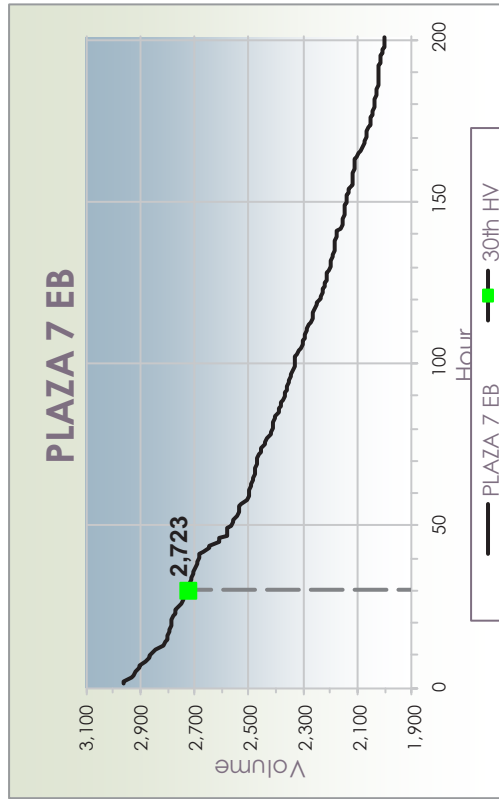

FIGURE 2-A

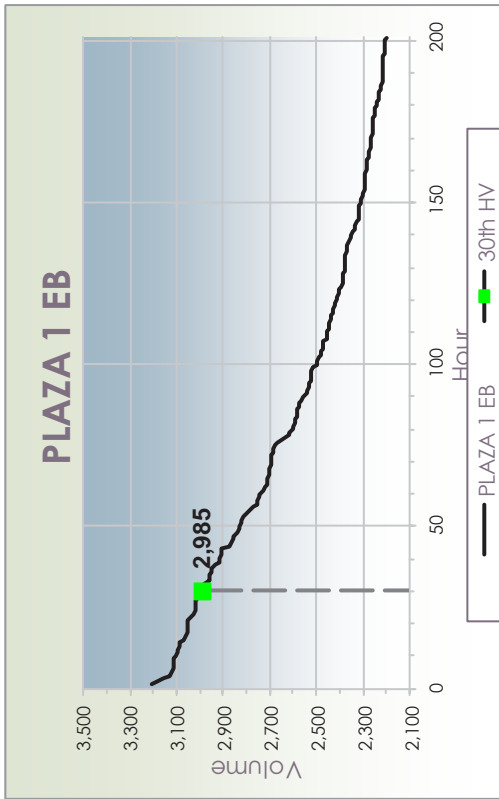
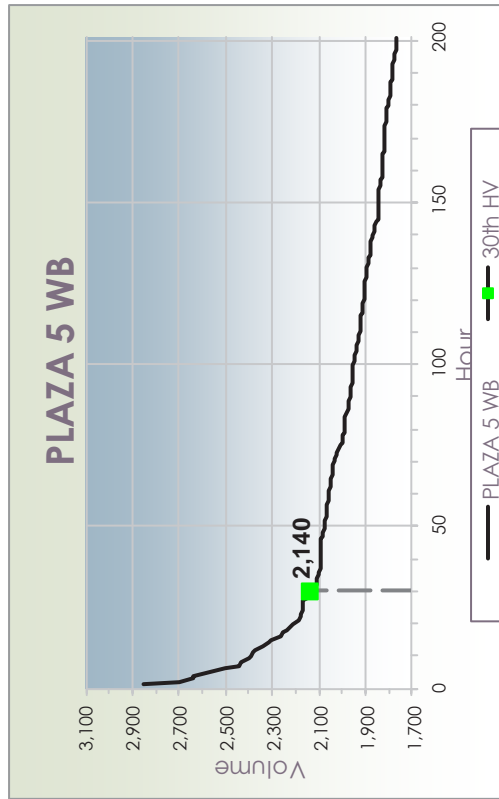

FIGURE 2-C



MAINLINE PLAZA HIGHEST HOURLY VOLUME



FIGURE 2-F

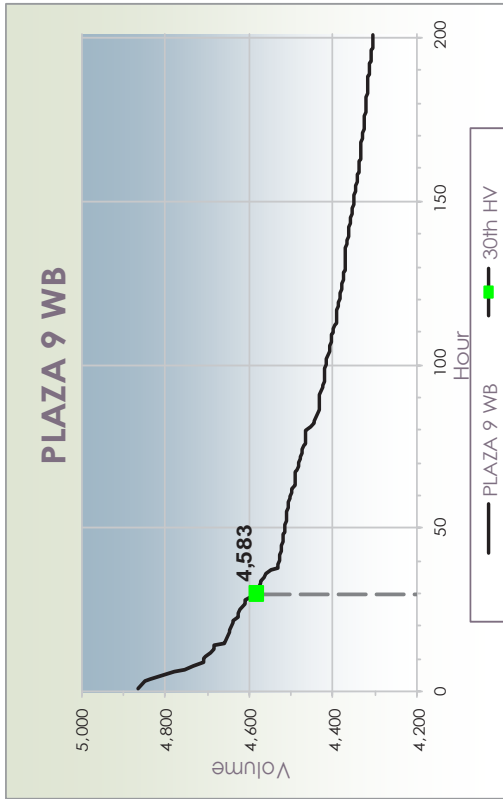

FIGURE 2-H

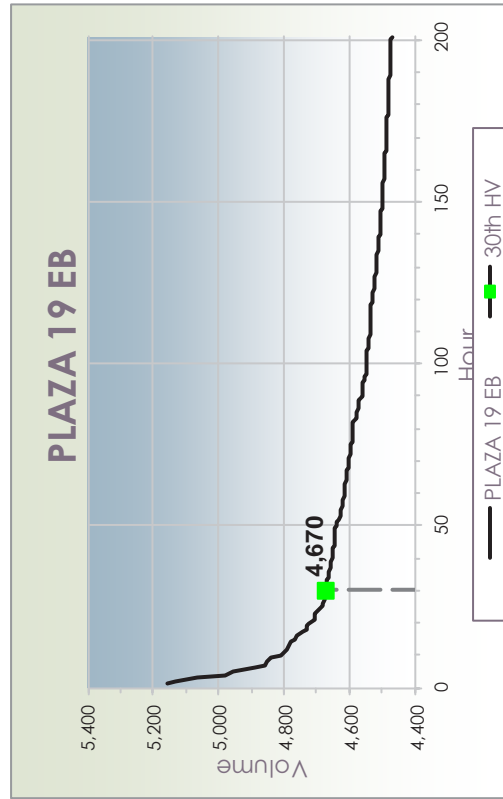

FIGURE 2-E

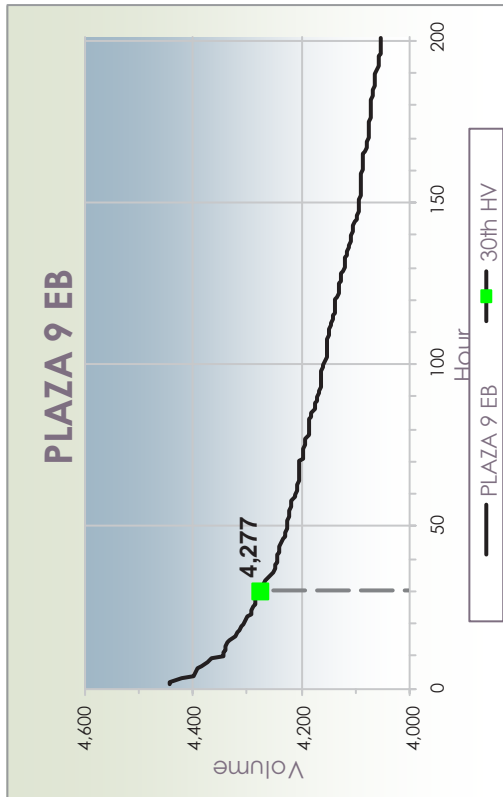
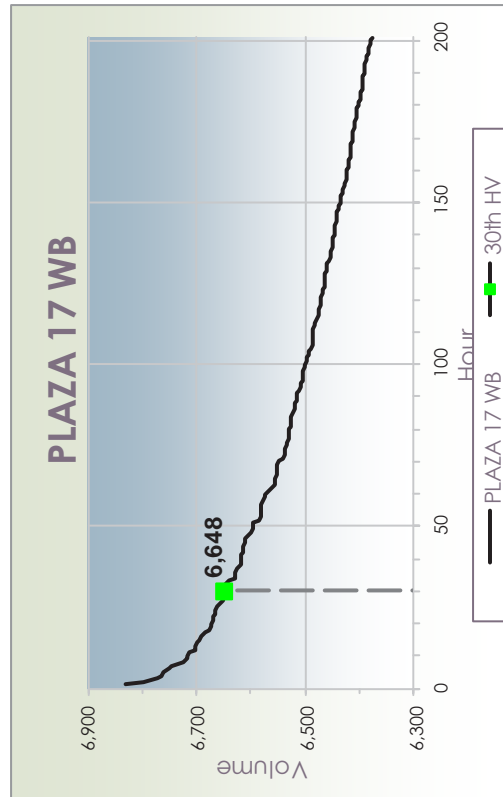

FIGURE 2-G



MAINLINE PLAZA HIGHEST HOURLY VOLUME



FIGURE 2-I

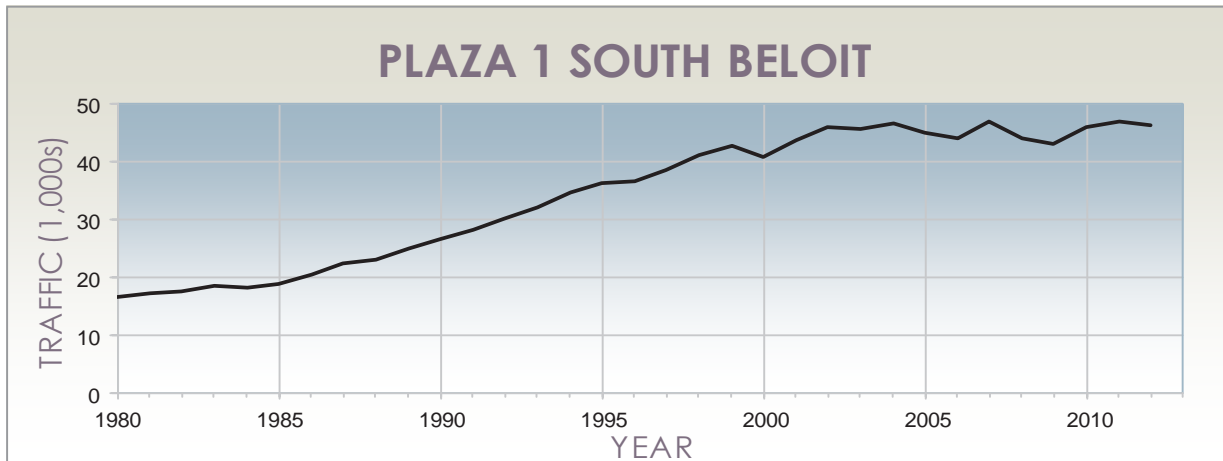

FIGURE 2-J

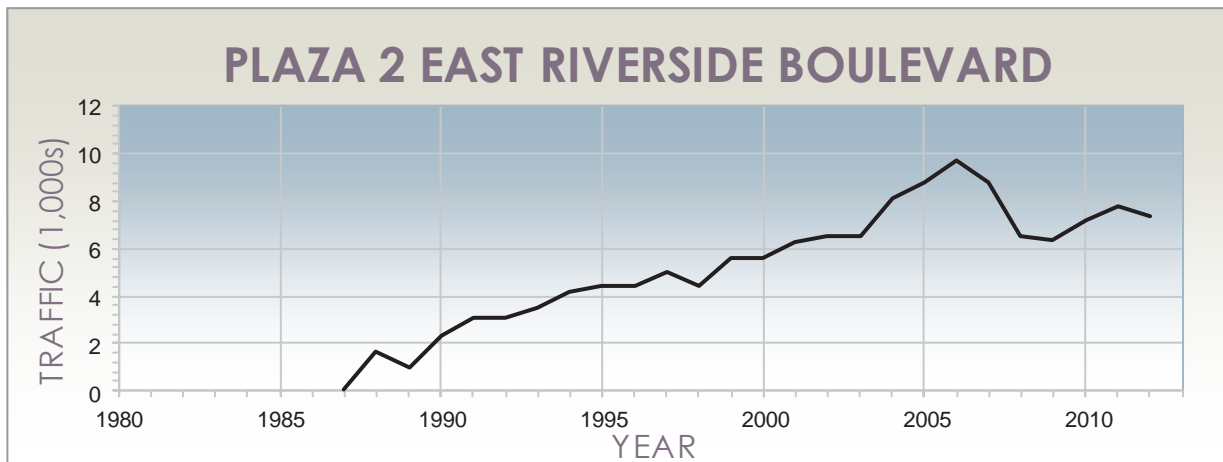
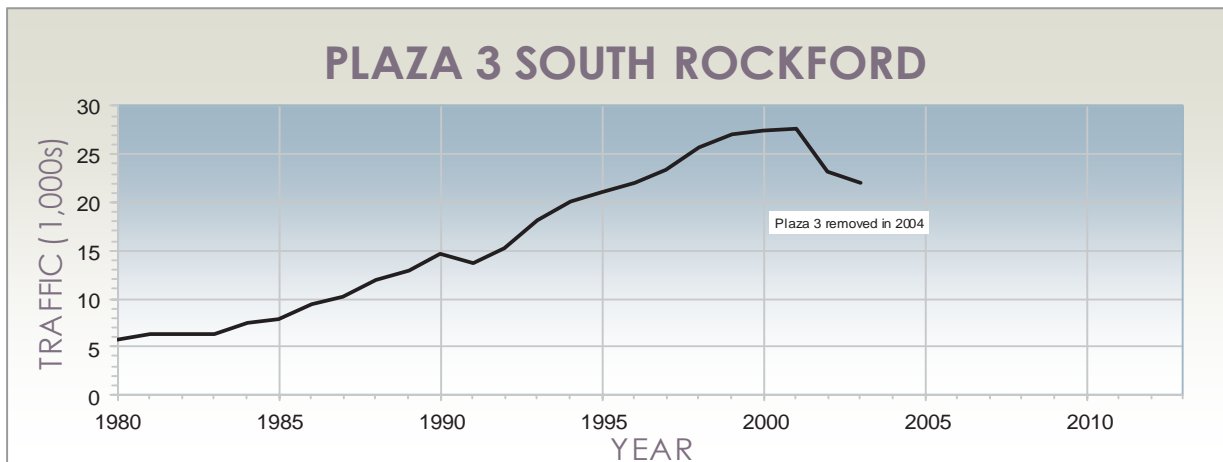

FIGURE 2-K



AVERAGE DAILY TRAFFIC TRENDS



FIGURE 2-L

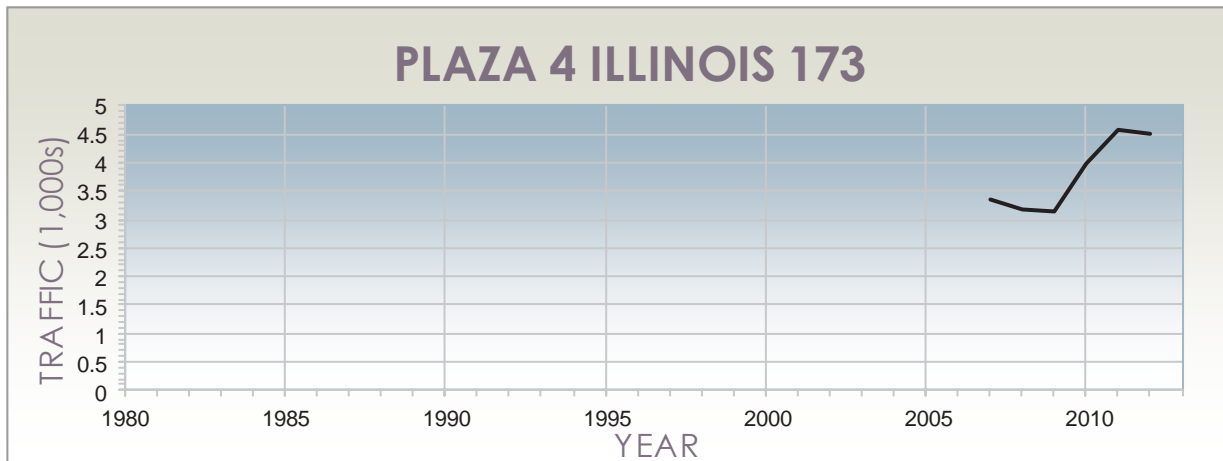

FIGURE 2-M

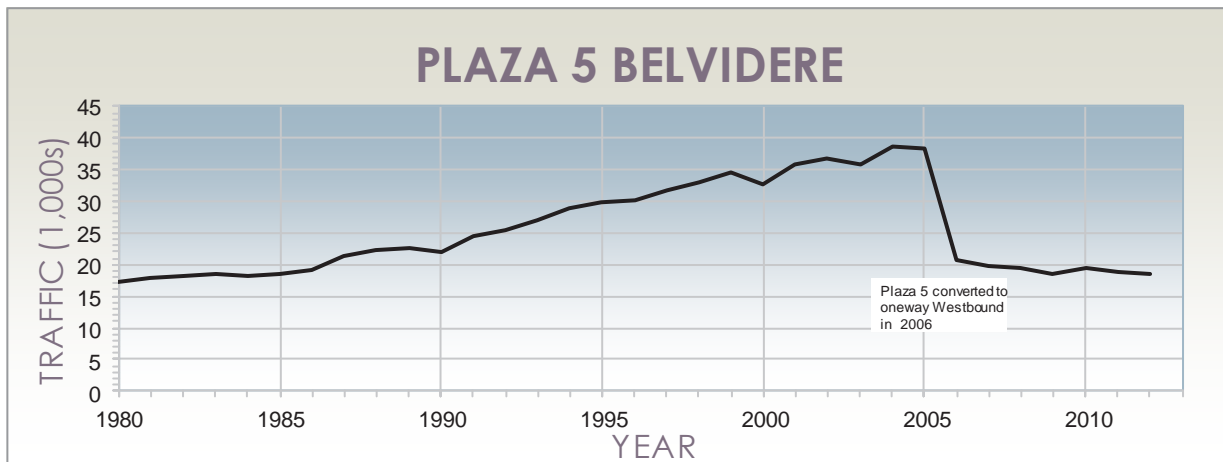
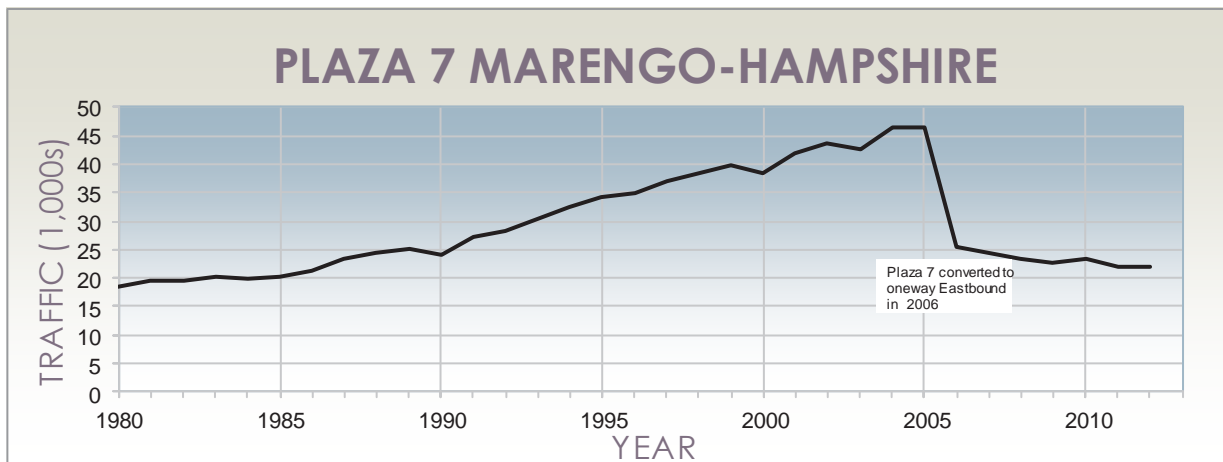

FIGURE 2-N



AVERAGE DAILY TRAFFIC TRENDS



FIGURE 2-O

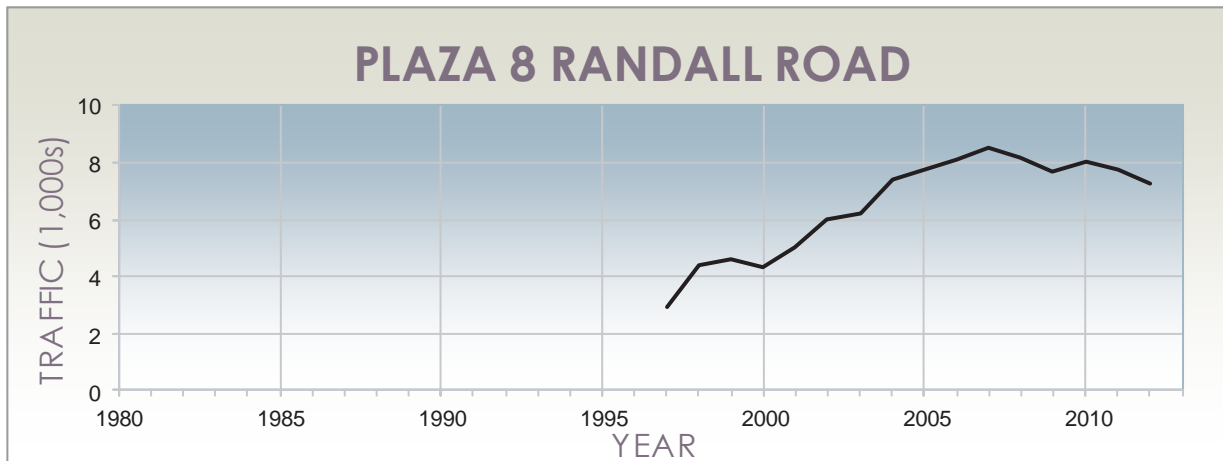

FIGURE 2-P

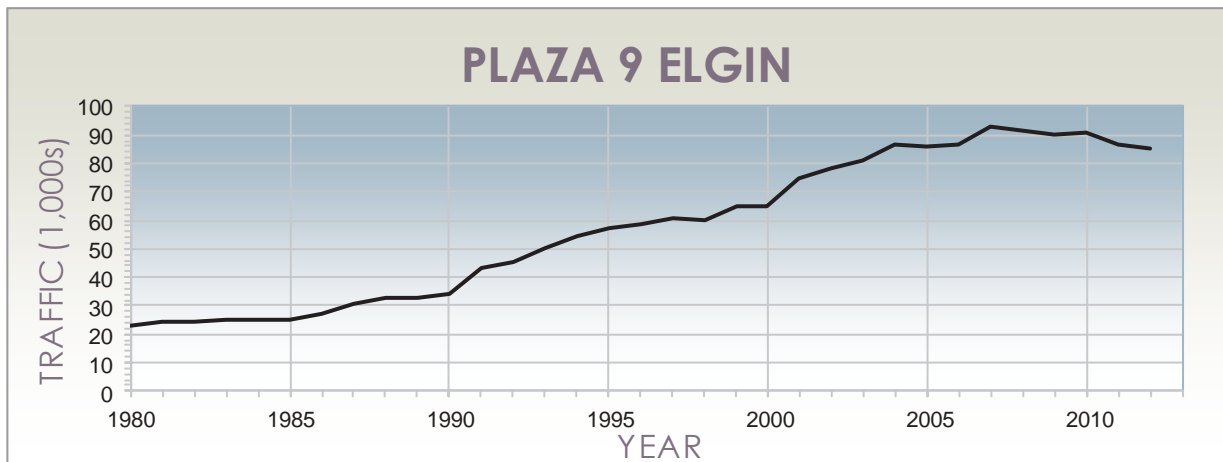
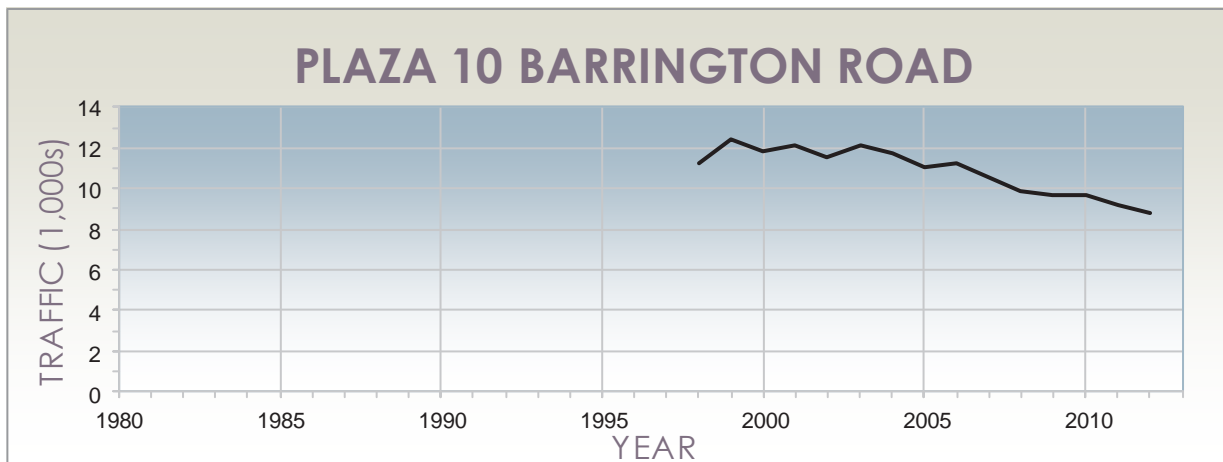

FIGURE 2-Q



AVERAGE DAILY TRAFFIC TRENDS



FIGURE 2-R

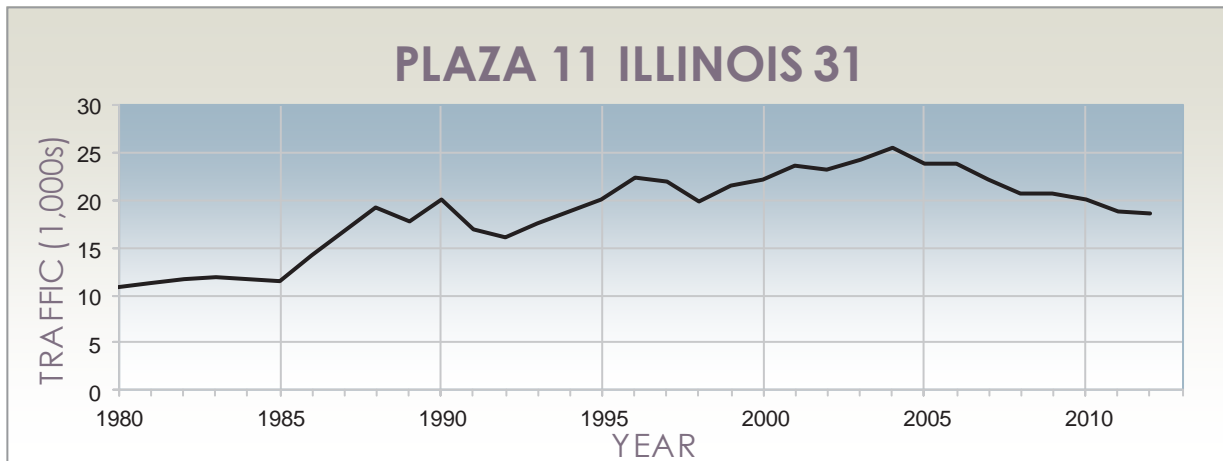

FIGURE 2-S

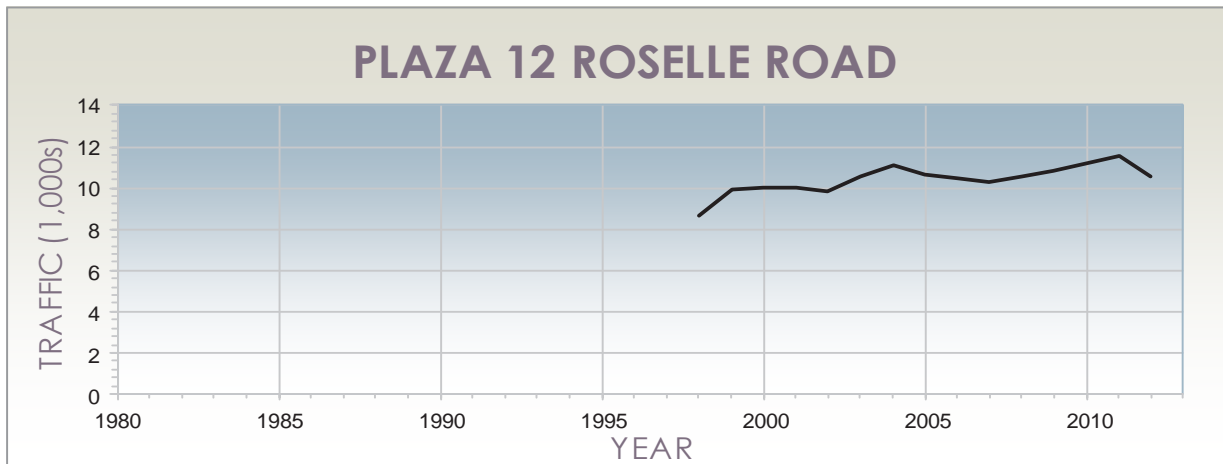
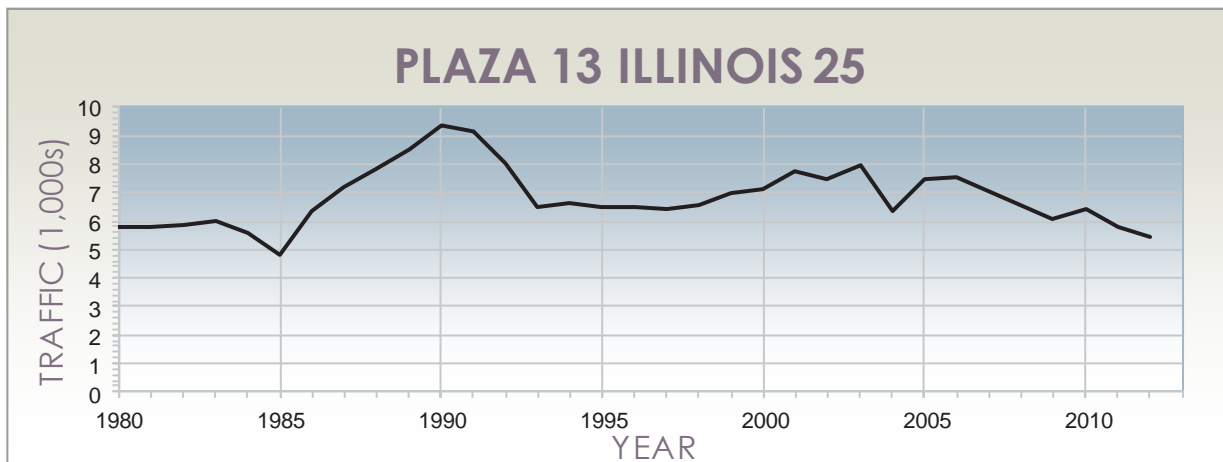

FIGURE 2-T



AVERAGE DAILY TRAFFIC TRENDS



FIGURE 2-U

Note: The Plaza 14 graph shows transactions at the EB I-90 to Route 59 collection point only. Transactions for the WB I-90 to Route 59 collection point are included with the Plaza 16 graph.

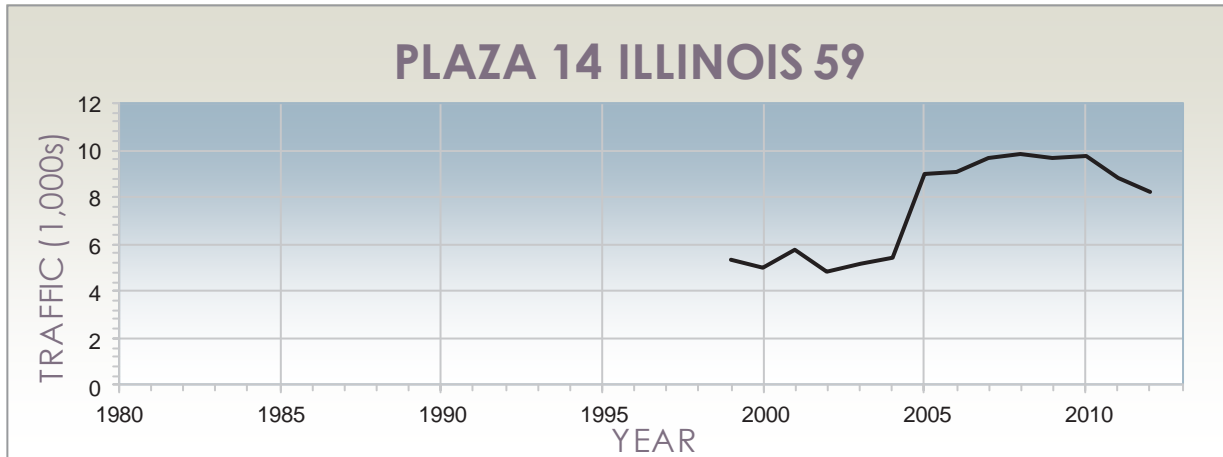

FIGURE 2-V

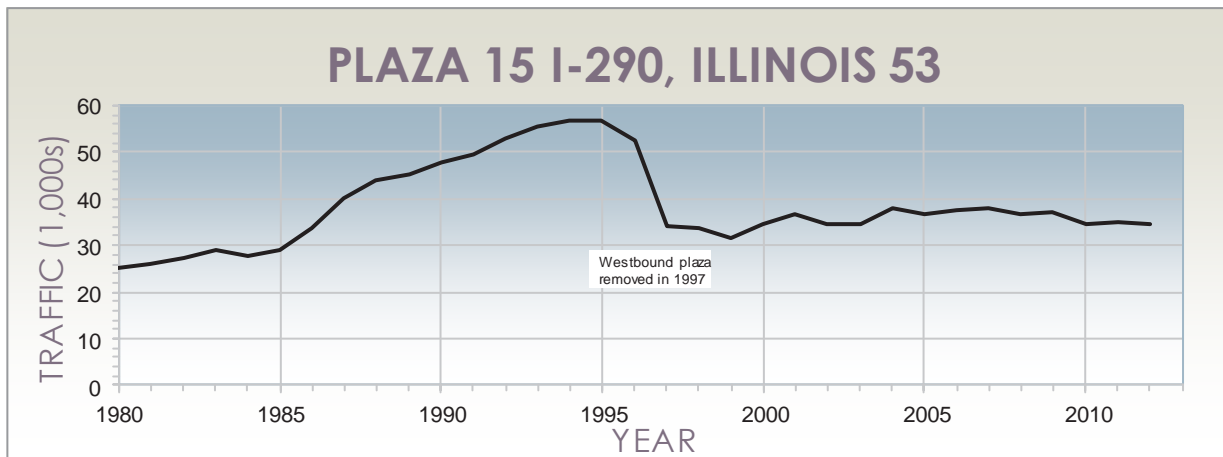
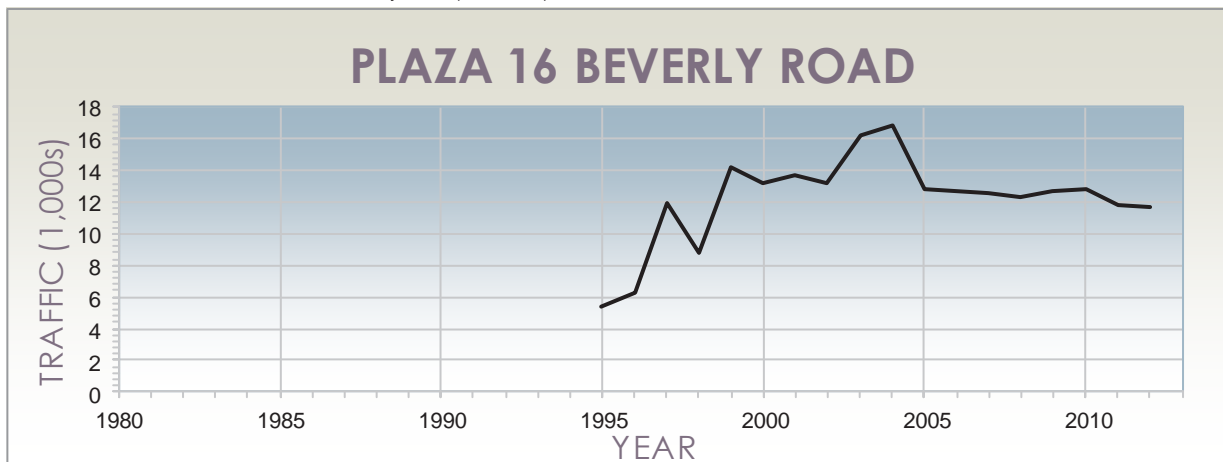

FIGURE 2-W

Note: The Plaza 16 graph shows transactions from two collection points: (1) WB I-90 to Route 59 (Plaza 16a) and (2) WB I-90 to Beverly Road (Plaza 16b).



AVERAGE DAILY TRAFFIC TRENDS



FIGURE 2-X

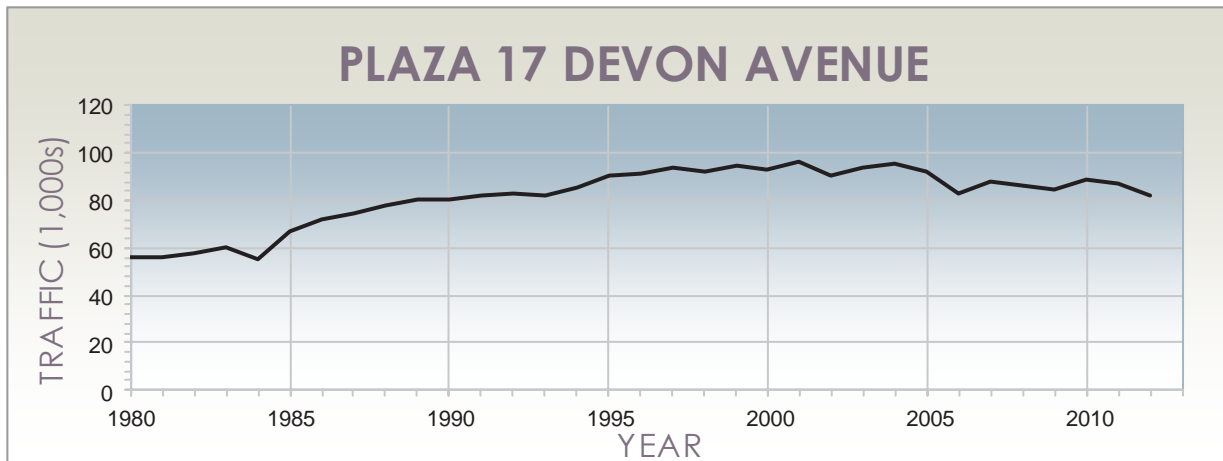

FIGURE 2-Y

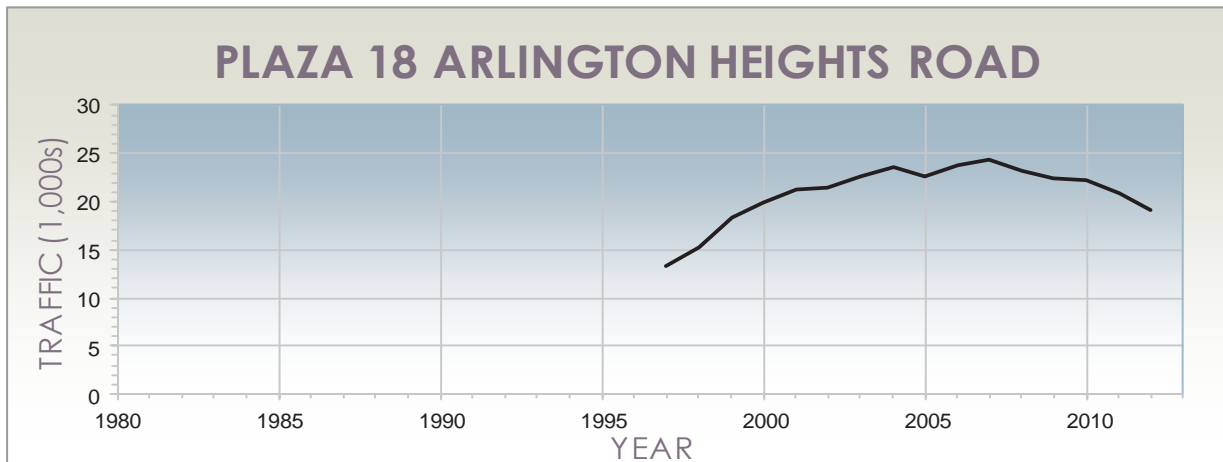
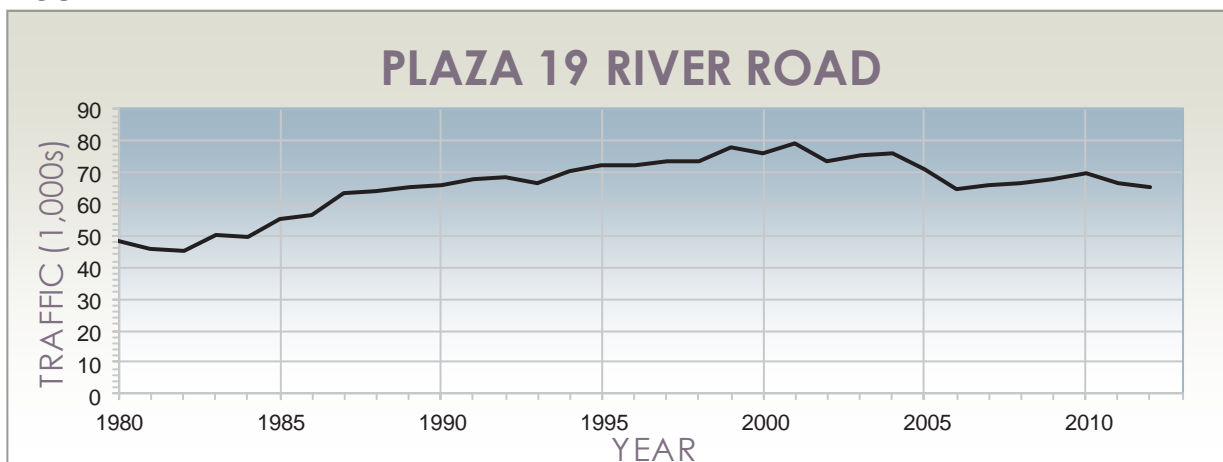

FIGURE 2-Z



AVERAGE DAILY TRAFFIC TRENDS

Section 3 Tab





SECTION 3

Tri-State Tollway

TABULATIONS TABLE

	PAGE
3-A1 Average Daily Traffic Volumes Between Interchanges 1980 – 2012 (Northbound-1)	3-4
3-B1 Average Daily Vehicle Miles Traveled Between Interchanges 1980 – 2012 (Northbound-1)	3-5
3-A2 Average Daily Traffic Volumes Between Interchanges 1980 – 2012 (Northbound-2)	3-6
3-B2 Average Daily Vehicle Miles Traveled Between Interchanges 1980 – 2012 (Northbound-2)	3-7
3-C1 Average Daily Traffic Volumes Between Interchanges 1980 – 2012 (Southbound-1)	3-8
3-D1 Average Daily Vehicle Miles Traveled Between Interchanges 1980 – 2012 (Southbound-1)	3-9
3-C2 Average Daily Traffic Volumes Between Interchanges 1980 – 2012 (Southbound-2)	3-10
3-D2 Average Daily Vehicle Miles Traveled Between Interchanges 1980 – 2012 (Southbound-2)	3-11
3-E General Statistics for Mainline Plazas	3-12
3-F Indexed Monthly Variation by Mainline Plaza	3-14
3-G Indexed Daily Variation by Mainline Plaza	3-14
3-H Annual Total Transactions by Toll Plaza	3-15
3-I Average Daily Traffic Data	3-16

ILLUSTRATIONS FIGURE

	PAGE
3-A Mainline Plaza Highest Hourly Volume Plaza 21 NB	3-17
3-B Mainline Plaza Highest Hourly Volume Plaza 21 SB	3-17
3-C Mainline Plaza Highest Hourly Volume Plaza 24 EB	3-17
3-D Mainline Plaza Highest Hourly Volume Plaza 24 WB	3-17
3-D Mainline Plaza Highest Hourly Volume Plaza 24 WB	3-17
3-E Mainline Plaza Highest Hourly Volume Plaza 29 NB	3-18
3-F Mainline Plaza Highest Hourly Volume Plaza 33 SB	3-18



SECTION 3

Tri-State Tollway

ILLUSTRATIONS FIGURE

PAGE

3-G	Mainline Plaza Highest Hourly Volume Plaza 35 NB	3-18
3-H	Mainline Plaza Highest Hourly Volume Plaza 35 SB	3-18
3-I	Mainline Plaza Highest Hourly Volume Plaza 36 SB	3-19
3-J	Mainline Plaza Highest Hourly Volume Plaza 39 NB	3-19
3-K	Mainline Plaza Highest Hourly Volume Plaza 41 NB	3-19
3-L	Mainline Plaza Highest Hourly Volume Plaza 41 SB	3-19
3-N	Average Daily Traffic Trends Plaza 21 Waukegan	3-20
3-O	Average Daily Traffic Trends Plaza 22 Townline Road	3-20
3-P	Average Daily Traffic Trends Plaza 23 Half Day Road	3-21
3-Q	Average Daily Traffic Trends Plaza 24 Edens Spur	3-21
3-R	Average Daily Traffic Trends Plaza 25 Deerfield Road	3-21
3-S	Average Daily Traffic Trends Plaza 26 Lake Cook Road	3-22
3-T	Average Daily Traffic Trends Plaza 27 Willow Road	3-22
3-U	Average Daily Traffic Trends Plaza 28 Golf Road	3-22
3-V	Average Daily Traffic Trends Plaza 29 Touhy Avenue	3-23
3-W	Average Daily Traffic Trends Plaza 30 Balmoral Avenue	3-23
3-X	Average Daily Traffic Trends Plaza 31 O'Hare West	3-23
3-Y	Average Daily Traffic Trends Plaza 32 O'Hare East	3-24
3-Z	Average Daily Traffic Trends Plaza 33 Irving Park Road	3-24
3-AA	Average Daily Traffic Trends Plaza 34 Willow Springs Road	3-24
3-AB	Average Daily Traffic Trends Plaza 35 Cermak Road	3-25
3-AC	Average Daily Traffic Trends Plaza 37 I-55	3-25
3-AD	Average Daily Traffic Trends Plaza 38 95th Street	3-25
3-AE	Average Daily Traffic Trends Plaza 36 & 39 (82nd Street & 83rd Street)	3-26
3-AF	Average Daily Traffic Trends Plaza 40 159th Street	3-26
3-AG	Average Daily Traffic Trends Plaza 41 163rd Street	3-26
3-AH	Average Daily Traffic Trends Plaza 43 & 45 I-80	3-27
3-AI	Average Daily Traffic Trends Plaza 47 Halsted Street	3-27



This Page Is Intentionally Left Blank



TABLE 3-A1: AVERAGE DAILY TRAFFIC VOLUMES BETWEEN INTERCHANGES 1980-2012 (NORTHBOUND-1)

Location	Mile Post	Miles Btwn. Int.	ADT 1980	Average Annual Percent Change	ADT 1990	Average Annual Percent Change	ADT 2000	Average Annual Percent Change	ADT 2010	Average Annual Percent Change	ADT 2012
Bishop Ford Fwy/Calumet Expy	0.0										
		0.8	32,090	5.0	52,400	1.4	60,000	2.2	74,800	0.8	75,990
Lincoln Oasis	0.8										
		1.9	32,090	5.0	52,400	1.4	60,000	2.2	74,800	0.8	75,990
Halsted St. (PL47)	2.7										
		1.3	30,070	5.1	49,550	1.2	55,610	2.8	73,290	0.0	73,290
Wood St.	4.0										
		0.2	32,700	5.1	53,610	0.8	57,980	2.8	76,610	0.0	76,680
Dixie Highway	4.2										
		0.9	32,700	5.1	53,610	0.8	57,980	2.8	76,610	0.0	76,680
I-80 (PL43 & 45)	5.1										
Plaza 41	5.6	1.2	25,440	4.9	40,940	-0.4	39,520	2.4	49,880	-0.7	49,200
159th St. (PL40)	6.3										
		5.7	24,250	4.9	39,250	1.6	45,790	1.0	50,740	-0.2	50,530
Cicero Ave. (IL50)	12.0										
		5.5	26,970	4.9	43,610	2.9	58,210	-0.3	56,490	-0.6	55,860
95th St. (PL38)	17.5										
Plaza 39	19.5	2.8	35,890	4.2	53,970	2.8	70,920	-0.7	66,260	-0.8	65,200
79th St./Archer Ave.	20.3										
		1.7	33,380	4.2	50,370	3.5	70,920	-0.7	66,260	-0.8	65,200
Willow Springs Rd. (PL34)	22.0										
		1.1	33,380	4.2	50,370	3.5	71,300	-0.7	66,630	-1.1	65,190
I-55 EB	23.1										
		0.2	31,230	4.2	47,190	3.4	65,740	-0.4	63,070	-1.0	61,780
Wolf Rd. & I-55 WB	23.3										
		0.8	28,380	3.8	41,260	2.8	54,250	0.2	55,330	-0.9	54,360
PL 37 (I-55)	24.1										
		0.9	45,400	3.3	62,620	2.0	76,420	0.8	83,150	-2.4	79,150
Hinsdale Oasis	25.0										
		2.4	45,400	3.3	62,620	2.4	79,570	0.8	86,270	-2.4	82,110
Ogden Ave. (US34)	27.4										
		1.6	44,710	3.5	62,980	2.1	77,300	1.0	85,260	-2.1	81,750
Reagan Mem. Twy. Connector	29.0										
		0.5	37,610	2.8	49,760	2.2	62,050	0.6	66,010	-2.1	63,290
Cermak Rd.	29.5										
Plaza 35	29.9	1.0	39,360	2.9	52,420	2.4	66,410	0.3	68,280	-3.0	64,260
Roosevelt Rd. (IL38)	30.5										
		0.6	37,590	2.9	49,900	2.1	61,270	0.6	64,930	-2.7	61,460
Reagan Memorial Twy (I-88)	31.1										
		0.5	44,050	0.8	47,710	1.2	53,500	1.9	64,820	-0.4	64,350
Eisenhower Expy (I-290)	31.6										
		2.0	40,130	2.5	51,370	1.7	60,900	1.3	69,560	-0.1	69,420
IL64 & US20	33.6										
		4.2	47,320	2.6	61,300	1.9	74,020	1.0	81,990	0.4	82,710
O'Hare Oasis	37.8										
		0.5	47,320	2.6	61,300	1.9	74,020	1.0	81,990	0.4	82,710
Irving Park Rd. (IL19)	38.3										
Plaza 33	38.9	1.5	53,050	3.1	71,830	1.7	85,080	1.0	93,650	0.1	93,930
Balmoral Ave.	39.8										



TABLE 3-B1: AVERAGE DAILY VEHICLE MILES TRAVELED BETWEEN INTERCHANGES 1980-2012 (NORTHBOUND-1)

Location	Mile Post	Miles Btwn. Int.	Daily Vehicle Miles				
			1980	1990	2000	2010	2012
Bishop Ford Fwy/Calumet Expy	0.0	0.8	25,672	41,920	48,000	59,840	60,792
Lincoln Oasis	0.8	1.9	60,971	99,560	114,000	142,120	144,381
Halsted St. (PL47)	2.7	1.3	39,091	64,415	72,293	95,277	95,277
Wood St.	4.0	0.2	6,540	10,722	11,596	15,322	15,336
Dixie Highway	4.2	0.9	29,430	48,249	52,182	68,949	69,012
I-80 (PL43 & 45)	5.1	5.7	138,225	223,725	261,003	289,218	288,021
Plaza 41	5.6	1.2	30,528	49,128	47,424	59,856	59,040
159th St. (PL40)	6.3	5.5	148,335	239,855	320,155	310,695	307,230
Cicero Ave. (IL50)	12.0	2.8	100,492	151,116	198,576	185,528	182,560
95th St. (PL38)	17.5	1.7	56,746	85,629	120,564	112,642	110,840
Plaza 39	19.5	1.1	36,718	55,407	78,430	73,293	71,709
79th St./Archer Ave.	20.3	0.2	6,246	9,438	13,148	12,614	12,356
Willow Springs Rd. (PL34)	22.0	0.8	22,704	33,008	43,400	44,264	43,488
I-55 EB	23.1	0.9	40,860	56,358	68,778	74,835	71,235
Wolf Rd. & I-55 WB	23.3	2.4	108,960	150,288	190,968	207,048	197,064
PL 37 (I-55)	24.1	1.6	71,536	100,768	123,680	136,416	130,800
Hinsdale Oasis	25.0	0.5	18,805	24,880	31,025	33,005	31,645
Ogden Ave. (US34)	27.4	1.0	39,360	52,420	66,410	68,280	64,260
Reagan Mem. Twy. Connector	29.0	0.6	22,554	29,940	36,762	38,958	36,876
Cermak Rd.	29.5	0.5	22,025	23,855	26,750	32,410	32,175
Plaza 35	29.9	2.0	80,260	102,740	121,800	139,120	138,840
Roosevelt Rd. (IL38)	30.5	4.2	198,744	257,460	310,884	344,358	347,382
Reagan Memorial Twy (I-88)	31.1	0.5	23,660	30,650	37,010	40,995	41,355
Eisenhower Expy (I-290)	31.6	1.5	79,575	107,745	127,620	140,475	140,895
IL64 & US20	33.6	0.5	23,660	30,650	37,010	40,995	41,355
O'Hare Oasis	37.8	0.5	23,660	30,650	37,010	40,995	41,355
Irving Park Rd. (IL19)	38.3	1.5	79,575	107,745	127,620	140,475	140,895
Plaza 33	38.9	1.5	79,575	107,745	127,620	140,475	140,895
Balmoral Ave.	39.8						



TABLE 3-A2: AVERAGE DAILY TRAFFIC VOLUMES BETWEEN INTERCHANGES 1980-2012 (NORTHBOUND-2)

Location	Mile Post	Miles Btwn. Int.	ADT 1980	Average Annual Percent Change	ADT 1990	Average Annual Percent Change	ADT 2000	Average Annual Percent Change	ADT 2010	Average Annual Percent Change	ADT 2012
Balmoral Ave.	39.8										
Kennedy Expy (I-190)	40.5	1.1	53,050	3.1	71,830	1.7	85,080	1.0	93,650	-2.6	88,780
Jane Addams Interchange	40.9										
Plaza 29	41.6	1.2	45,770	4.1	68,690	2.0	83,800	-0.1	82,840	-4.3	75,940
Touhy Ave.	42.1										
		2.1	39,730	4.3	60,690	2.1	74,390	0.3	76,590	-5.6	68,290
Demoster St. (US14)	44.2										
		1.0	29,250	4.0	43,230	2.4	55,050	0.1	55,450	8.4	65,190
Golf Rd. (IL58)	45.2										
		3.7	33,080	4.3	50,550	2.3	63,640	0.0	63,340	-5.2	56,890
Willow Rd. (PL27)	48.9										
		3.9	21,750	6.6	41,210	2.9	55,010	0.1	55,480	-6.9	48,040
Lake Cook Rd	52.8										
Edens Spur	30.0										
		2.3	8,120	8.5	18,300	2.3	22,880	-0.7	21,420	2.6	22,560
Waukegan Rd.	27.7										
		2.5	10,350	7.2	20,760	1.9	25,010	-0.3	24,280	2.7	25,590
Tri-State Tollway	25.2										
Lake Cook Road / I-94 / I-294	25.2										
		1.0	32,100	6.0	57,460	2.0	69,970	0.9	76,390	0.1	76,610
Deerfield Rd.	24.2										
		2.4	29,180	5.6	50,360	2.3	63,280	1.4	72,870	-0.2	72,550
Half Day Rd. (IL22/PL 23)	21.8										
		2.9	28,600	5.5	48,980	2.5	62,960	0.8	68,200	0.0	68,180
Town Line Rd. (IL60/PL22)	18.9										
		0.8	26,050	5.8	45,830	2.9	61,020	0.2	62,510	0.2	62,790
Lake Forest Oasis	18.1										
		2.1	26,050	5.8	45,830	2.9	61,020	0.2	62,510	0.2	62,790
Rockland Ave. (IL176)	16.0										
		2.2	24,220	5.6	41,940	3.1	56,670	0.3	58,280	0.2	58,570
Buckley Rd. (IL137)	13.8										
		2.6	22,310	5.5	38,070	3.3	52,860	0.3	54,570	-0.4	54,180
Belvidere Rd. (IL120)	11.2										
		1.1	18,840	5.1	31,010	3.2	42,380	0.5	44,450	-0.4	44,090
Milwaukee Ave. (IL21)	10.1										
		1.7	19,580	5.2	32,400	3.3	44,640	0.6	47,290	-0.4	46,940
Grand Ave. (IL132)	8.4										
Plaza 21	4.8	6.0	13,440	5.6	23,220	2.8	30,650	0.4	31,920	-0.5	31,620
Rosecrans Rd. (IL173)	2.4										
		1.2	12,580	5.4	21,250	2.6	27,590	0.3	28,340	-1.2	27,690
Mill Creek Rd.	1.2										
		0.4	12,580	5.4	21,250	2.6	27,590	0.3	28,340	-1.2	27,690
Skokie Hwy (US41)	0.8										
I-294 Subtotal		52.8	1,103,140	3.8	1,598,540	2.0	1,955,730	0.8	2,124,030	-0.5	2,009,960
Edens Spur Subtotal		4.8	18,470	7.8	39,060	2.1	47,890	-0.5	45,700	0.4	48,150
I-94 Subtotal		24.4	265,530	5.6	457,600	2.8	600,630	0.6	635,670	0.0	633,700
Tri-State Grand Total		82.0	1,387,140	4.2	2,095,200	2.2	2,604,250	0.7	2,805,400	-0.4	2,691,810



TABLE 3-B2: AVERAGE DAILY VEHICLE MILES TRAVELED BETWEEN INTERCHANGES 1980-2012 (NORTHBOUND-2)

Location	Mile Post	Miles Btwn. Int.	Daily Vehicle Miles				
			1980	1990	2000	2010	2012
Balmoral Ave.	39.8						
Kennedy Expy (I-190)	40.5	1.1	58,355	79,013	93,588	103,015	97,658
Jane Addams Interchange	40.9						
Plaza 29	41.6	1.2	54,924	82,428	100,560	99,408	91,128
Touhy Ave.	42.1						
		2.1	83,433	127,449	156,219	160,839	143,409
Demoster St. (US14)	44.2						
		1.0	29,250	43,230	55,050	55,450	65,190
Golf Rd. (IL58)	45.2						
		3.7	122,396	187,035	235,468	234,358	210,493
Willow Rd. (PL27)	48.9						
		3.9	84,825	160,719	214,539	216,372	187,356
Lake Cook Rd	52.8						
Edens Spur	30.0						
		2.3	18,676	42,090	52,624	49,266	51,888
Waukegan Rd.	27.7						
		2.5	25,875	51,900	62,525	60,700	63,975
Tri-State Tollway	25.2						
Lake Cook Road / I-94 / I-294	25.2						
		1.0	32,100	57,460	69,970	76,390	76,610
Deerfield Rd.	24.2						
		2.4	70,032	120,864	151,872	174,888	174,120
Half Day Rd. (IL22/PL 23)	21.8						
		2.9	82,940	142,042	182,584	197,780	197,722
Town Line Rd. (IL60/PI22)	18.9						
		0.8	20,840	36,664	48,816	50,008	50,232
Lake Forest Oasis	18.1						
		2.1	54,705	96,243	128,142	131,271	131,859
Rockland Ave. (IL176)	16.0						
		2.2	53,284	92,268	124,674	128,216	128,854
Buckley Rd. (IL137)	13.8						
		2.6	58,006	98,982	137,436	141,882	140,868
Belvidere Rd. (IL120)	11.2						
		1.1	20,724	34,111	46,618	48,895	48,499
Milwaukee Ave. (IL21)	10.1						
		1.7	33,286	55,080	75,888	80,393	79,798
Grand Ave. (IL132)	8.4						
Plaza 21	4.8	6.0	80,640	139,320	183,900	191,520	189,720
Rosecrans Rd. (IL173)	2.4						
		1.2	15,096	25,500	33,108	34,008	33,228
Mill Creek Rd.	1.2						
		0.4	5,032	8,500	11,036	11,336	11,076
Skokie Hwy (US41)	0.8						
I-294 Subtotal		52.8	1,841,220	2,729,150	3,377,882	3,594,960	3,423,543
Edens Spur Subtotal		4.8	44,551	93,990	115,149	109,966	115,863
I-94 Subtotal		24.4	526,685	907,034	1,194,044	1,266,587	1,262,586
Tri-State Grand Total		82.0	2,412,456	3,730,174	4,687,075	4,971,513	4,801,992



TABLE 3-C1: AVERAGE DAILY TRAFFIC VOLUMES BETWEEN INTERCHANGES 1980-2012 (SOUTHBOUND-1)

Location	Mile Post	Miles Btwn. Int.	ADT 1980	Average Annual Percent Change	ADT 1990	Average Annual Percent Change	ADT 2000	Average Annual Percent Change	ADT 2010	Average Annual Percent Change	ADT 2012
Calumet Expy (IL394)	0.0										
		0.8	32,160	4.9	51,770	0.9	56,630	2.9	75,700	-1.0	74,210
Lincoln Oasis	0.8										
		1.9	32,160	4.9	51,770	0.9	56,630	2.9	75,700	-1.0	74,210
Halsted St. (Pl 47)	2.7										
		1.3	30,260	5.0	49,300	0.8	53,380	3.1	72,100	-0.5	71,430
Wood St.	4.0										
		0.2	30,260	5.0	49,300	0.8	53,380	3.1	72,100	-0.5	71,430
Dixie Highway	4.2										
		0.9	33,000	4.9	53,370	0.7	57,100	2.9	75,790	0.0	75,790
I-80 (Pl 43 & 45)	5.1										
Plaza 41	5.6	1.2	25,850	4.7	40,770	-0.4	39,050	2.4	49,600	-1.1	48,470
159th St. (Pl46)	6.3										
		5.7	24,400	4.8	39,050	1.2	44,180	1.2	49,570	-0.8	48,810
127th St. & Cicero (IL50)	12.0										
		5.5	27,290	4.6	42,590	2.8	56,350	-0.4	54,280	-0.6	53,600
95th St. (US12&20)	17.5										
Plaza 36	19.5	2.8	35,750	4.0	53,170	2.9	70,920	-0.5	67,510	-1.2	65,870
79th St./Archer Ave.	20.3										
		1.7	30,530	4.0	45,290	3.8	65,790	-0.4	63,000	-1.2	61,460
Willow Springs Rd./75th Street	22.0										
		1.1	30,530	4.0	45,290	4.1	67,370	-0.4	64,420	-1.4	62,600
Interstate 55 (No SB Ramps)	23.1										
		0.2	30,530	4.0	45,290	4.1	67,370	2.5	86,050	-2.4	82,040
Wolf Rd. & NB I-55 Entrance	23.3										
		0.8	27,460	3.3	37,980	3.6	54,270	0.2	55,200	-1.5	53,590
Interstate 55	24.1										
		0.9	45,140	3.0	60,840	2.9	80,730	0.6	86,050	-2.4	82,040
Hinsdale Oasis	25.0										
		2.4	45,140	3.0	60,840	2.9	80,730	0.6	86,050	-2.4	82,040
Ogden Ave. (US34)	27.4										
		1.6	44,450	3.2	60,940	2.9	80,940	0.6	86,180	-2.2	82,500
Reagan Mem. Twy Connector	29.0										
		0.5	37,400	2.5	47,760	3.7	68,440	-0.2	67,060	-2.4	63,820
Cermak Rd.	29.5										
Plaza 35	29.9	1.0	39,160	2.5	50,330	3.6	71,370	-0.3	69,070	-3.0	65,030
Roosevelt Rd. (IL38)	30.5										
		0.6	37,330	2.6	48,030	3.5	67,520	-0.4	65,020	-2.9	61,280
Reagan Mem. Twy (I-88)	31.1										
		0.5	43,340	4.2	65,600	2.9	87,710	0.4	91,100	-2.7	86,310
Eisenhower Expy (I-290)	31.6										
		2.0	39,180	2.5	50,360	3.4	70,590	0.6	74,620	-1.7	72,080
IL64 & US20	33.6										
		4.2	46,280	2.7	60,310	3.2	82,840	0.3	85,070	-1.0	83,340
O'Hare Oasis	37.8										
		0.5	46,280	2.7	60,310	3.2	82,840	0.3	85,070	-1.0	83,340
Irving Park Rd. (IL19)	38.3										
Plaza 33	38.9	1.5	51,960	3.2	70,940	2.9	94,270	0.2	96,260	-2.2	92,150
Balmoral Ave.	39.8										



TABLE 3-D1: AVERAGE DAILY VEHICLE MILES TRAVELED BETWEEN INTERCHANGES 1980-2012 (SOUTHBOUND-1)

Location	Mile Post	Miles Btwn. Int.	Daily Vehicle Miles				
			1980	1990	2000	2010	2012
Calumet Expy (IL394)	0.0						
		0.8	25,728	41,416	45,304	60,560	59,368
Lincoln Oasis	0.8						
		1.9	61,104	98,363	107,597	143,830	140,999
Halsted St. (PI 47)	2.7						
		1.3	39,338	64,090	69,394	93,730	92,859
Wood St.	4.0						
		0.2	6,052	9,860	10,676	14,420	14,286
Dixie Highway	4.2						
		0.9	29,700	48,033	51,390	68,211	68,211
I-80 (PL 43 & 45)	5.1						
Plaza 41	5.6	1.2	31,020	48,924	46,860	59,520	58,164
159th St. (PL46)	6.3						
		5.7	139,080	222,585	251,826	282,549	278,217
127th St. & Cicero (IL50)	12.0						
		5.5	150,095	234,245	309,925	298,540	294,800
95th St. (US12&20)	17.5						
Plaza 36	19.5	2.8	100,100	148,876	198,576	189,028	184,436
79th St./Archer Ave.	20.3						
		1.7	51,901	76,993	111,843	107,100	104,482
Willow Springs Rd./75th Street	22.0						
		1.1	33,583	49,819	74,107	70,862	68,860
Interstate 55 (No SB Ramps)	23.1						
		0.2	6,106	9,058	13,474	17,210	16,408
Wolf Rd. & NB I-55 Entrance	23.3						
		0.8	21,968	30,384	43,416	44,160	42,872
Interstate 55	24.1						
		0.9	40,626	54,756	72,657	77,445	73,836
Hinsdale Oasis	25.0						
		2.4	108,336	146,016	193,752	206,520	196,896
Ogden Ave. (US34)	27.4						
		1.6	71,120	97,504	129,504	137,888	132,000
Reagan Mem. Twy Connector	29.0						
		0.5	18,700	23,880	34,220	33,530	31,910
Cermak Rd.	29.5						
Plaza 35	29.9	1.0	39,160	50,330	71,370	69,070	65,030
Roosevelt Rd. (IL38)	30.5						
		0.6	22,398	28,818	40,512	39,012	36,768
Reagan Mem. Twy (I-88)	31.1						
		0.5	21,670	32,800	43,855	45,550	43,155
Eisenhower Expy (I-290)	31.6						
		2.0	78,360	100,720	141,180	149,240	144,160
IL64 & US20	33.6						
		4.2	194,376	253,302	347,928	357,294	350,028
O'Hare Oasis	37.8						
		0.5	23,140	30,155	41,420	42,535	41,670
Irving Park Rd. (IL19)	38.3						
Plaza 33	38.9	1.5	77,940	106,410	141,405	144,390	138,225
Balmoral Ave.	39.8						



TABLE 3-C2: AVERAGE DAILY TRAFFIC VOLUMES BETWEEN INTERCHANGES 1980-2012 (SOUTHBOUND-2)

Location	Mile Post	Miles Btwn. Int.	ADT 1980	Average Annual Percent Change	ADT 1990	Average Annual Percent Change	ADT 2000	Average Annual Percent Change	ADT 2010	Average Annual Percent Change	ADT 2012
Balmoral Ave.	39.8										
	40.5	1.1	51,960	3.2	70,940	2.6	91,700	-0.2	90,200	-2.2	86,220
O'Hare Intchg. (I-90/I-294/I-190)	40.9										
Plaza 29	41.6	1.2	45,980	4.5	71,500	1.0	79,140	-0.1	78,040	3.3	83,310
Touhy Ave.	42.1										
		2.1	39,940	4.8	63,660	0.9	69,290	-0.1	68,920	3.3	73,520
Dempster St. (US14)	44.2										
		1.0	29,520	4.6	46,460	0.6	49,170	0.0	49,030	5.0	54,030
Golf Rd. (IL58)	45.2										
		3.7	33,480	4.8	53,510	0.8	57,890	-0.1	57,080	4.1	61,830
Willow Rd. (PL27)	48.9										
		3.9	22,130	7.2	44,410	1.2	50,280	0.3	51,810	2.8	54,780
Lake-Cook Road	52.8										
Edens Expressway	30.0										
		2.3	8,500	8.0	18,420	2.3	23,100	-0.6	21,800	3.3	23,250
Waukegan Road	27.7										
		2.5	10,230	7.3	20,760	2.0	25,310	-0.1	25,010	3.3	26,670
Lake-Cook Road / I-94 / I-294	25.2										
Lake-Cook Road / I-94 / I-294	25.2										
		1.0	32,360	6.5	60,480	1.6	70,900	0.8	76,560	2.7	80,700
Deerfield Rd.	24.2										
		2.4	29,260	6.2	53,160	2.0	64,960	0.7	69,920	3.3	74,570
Half Day Rd. (IL22/PL23)	21.8										
		2.9	28,440	6.1	51,480	2.3	64,320	0.3	66,210	3.2	70,450
Town Line Rd. (IL60/PL22)	18.9										
		0.8	25,900	6.4	48,000	2.6	62,080	-0.2	61,150	3.1	65,000
Lake Forest Oasis	18.1										
		2.1	25,900	6.4	48,000	2.6	62,080	-0.2	61,150	3.1	65,000
Rockland Rd. (IL176)	16.0										
		2.2	24,080	6.2	43,780	2.8	57,680	0.0	57,430	3.1	60,990
Buckley Rd. (IL137/PL20)	13.8										
		2.6	22,100	6.0	39,560	3.0	53,310	0.0	53,370	2.1	55,670
Belvidere Rd. (IL120)	11.2										
		1.1	18,770	5.6	32,240	2.7	41,900	0.4	43,600	1.8	45,140
Milwaukee Ave. (IL21)	10.1										
		1.7	19,580	5.5	33,590	2.8	44,350	0.5	46,680	1.4	47,990
Grand Ave. (IL132)	8.4										
Plaza 21	4.8	6.0	13,520	5.8	23,690	2.8	31,270	0.5	32,730	-0.2	32,570
Rosecrans Rd. (IL173)	2.4										
		1.2	12,380	5.8	21,740	2.5	27,960	0.3	28,800	-0.2	28,660
US 41	1.2										
		0.4	11,410	5.7	19,830	2.8	26,110	3.4	36,630	1.0	37,330
Russell Road (West Terminus)	0.8										
I-294 Subtotal		52.8	1,088,850	3.9	1,591,680	2.4	2,007,870	0.7	2,147,650	-0.9	2,111,130
Edens Spur Subtotal		4.8	18,730	7.7	39,180	2.1	48,410	-0.3	46,810	3.3	49,920
I-94 Subtotal		24.4	263,700	6.1	475,550	2.5	606,920	0.4	634,230	2.3	664,070
Tri-State Grand Total		82.0	1,371,280	4.4	2,106,410	2.4	2,663,200	0.6	2,828,690	-0.1	2,825,120



TABLE 3-D2: AVERAGE DAILY VEHICLE MILES TRAVELED BETWEEN INTERCHANGES 1980-2012 (SOUTHBOUND-2)

Location	Mile Post	Miles Btwn. Int.	Daily Vehicle Miles				
			1980	1990	2000	2010	2012
Balmoral Ave.	39.8						
	40.5	1.1	57,156	78,034	100,870	99,220	94,842
O'Hare Intchg. (I-90/I-294/I-190)	40.9						
Plaza 29	41.6	1.2	55,176	85,800	94,968	93,648	99,972
Touhy Ave.	42.1						
		2.1	83,874	133,686	145,509	144,732	154,392
Demoster St. (US14)	44.2						
		1.0	29,520	46,460	49,170	49,030	54,030
Golf Rd. (IL58)	45.2						
		3.7	123,876	197,987	214,193	211,196	228,771
Willow Rd. (PL27)	48.9						
		3.9	86,307	173,199	196,092	202,059	213,642
Lake-Cook Road	52.8						
Edens Expressway	30.0						
		2.3	19,550	42,366	53,130	50,140	53,475
Waukegan Road	27.7						
		2.5	25,575	51,900	63,275	62,525	66,675
Lake-Cook Road / I-94 / I-294	25.2						
		1.0	32,360	60,480	70,900	76,560	80,700
Deerfield Rd.	24.2						
		2.4	70,224	127,584	155,904	167,808	178,968
Half Day Rd. (IL22/PL23)	21.8						
		2.9	82,476	149,292	186,528	192,009	204,305
Town Line Rd. (IL60/PL22)	18.9						
		0.8	20,720	38,400	49,664	48,920	52,000
Lake Forest Oasis	18.1						
		2.1	54,390	100,800	130,368	128,415	136,500
Rockland Rd. (IL176)	16.0						
		2.2	52,976	96,316	126,896	126,346	134,178
Buckley Rd. (IL137/PL20)	13.8						
		2.6	57,460	102,856	138,606	138,762	144,742
Belvidere Rd. (IL120)	11.2						
		1.1	20,647	35,464	46,090	47,960	49,654
Milwaukee Ave. (IL21)	10.1						
		1.7	33,286	57,103	75,395	79,356	81,583
Grand Ave. (IL132)	8.4						
Plaza 21	4.8	6.0	81,120	142,140	187,620	196,380	195,420
Rosecrans Rd. (IL173)	2.4						
		1.2	14,856	26,088	33,552	34,560	34,392
US 41	1.2						
		0.4	4,564	7,932	10,444	14,652	14,932
Russell Road (West Terminus)	0.8						
I-294 Subtotal		52.8	1,827,510	2,722,503	3,392,993	3,670,588	3,523,289
Edens Spur Subtotal		4.8	45,125	94,266	116,405	115,467	120,150
I-94 Subtotal		24.4	525,079	944,455	1,211,967	1,250,719	1,307,374
Tri-State Grand Total		82.0	2,397,714	3,761,224	4,721,365	5,036,774	4,950,813



**TABLE 3-E: GENERAL STATISTICS FOR MAINLINE PLAZAS
(Vehicles/Hour)**

Mainline Plaza	Dir.	30th HV	Period	Mean	Med.	Max.	Min.	Std. Dev.	85th %
21 Waukegan	NB	3,804	AM Peak	1,367	1,369	1,768	861	177	1,559
			PM Peak	2,941	2,955	3,630	1,713	258	3,186
			OFF Peak	1,512	1,527	3,369	458	495	2,003
			Weekend	1,362	1,301	4,258	87	922	2,306
			Holidays	1,313	1,144	4,033	77	957	2,349
	SB	3,890	AM Peak	2,758	2,700	3,490	1,534	350	3,158
			PM Peak	1,681	1,661	2,301	851	191	1,878
			OFF Peak	1,578	1,621	2,695	441	456	2,053
			Weekend	1,384	1,382	4,756	111	918	2,336
			Holidays	1,385	1,332	4,807	71	982	2,302
24 Edens Spur	EB	2,688	AM Peak	2,364	2,369	2,806	1,403	249	2,632
			PM Peak	1,758	1,771	2,151	837	137	1,881
			OFF Peak	1,353	1,327	2,657	385	403	1,678
			Weekend	1,068	1,180	2,675	59	659	1,754
			Holidays	1,009	1,080	2,372	64	629	1,703
	WB	2,615	AM Peak	1,541	1,331	2,051	594	361	1,933
			PM Peak	2,302	2,322	2,766	1,396	176	2,469
			OFF Peak	1,313	1,263	2,608	321	454	1,867
			Weekend	1,013	1,011	2,826	98	633	1,704
			Holidays	939	888	2,874	58	637	1,617
29 Touhy Avenue	NB	8,820	AM Peak	7,554	7,397	9,190	4,323	936	8,635
			PM Peak	6,909	6,944	8,306	4,866	640	7,595
			OFF Peak	4,579	4,499	8,446	1,045	1,390	5,843
			Weekend	3,245	3,274	8,694	308	1,969	5,218
			Holidays	2,997	3,067	8,077	236	1,910	4,906
33 Irving Park Road	SB	8,663	AM Peak	6,273	5,546	8,089	3,470	1,213	7,618
			PM Peak	7,975	8,089	8,950	5,529	548	8,485
			OFF Peak	5,015	4,893	8,751	1,946	1,572	6,805
			Weekend	3,440	3,491	9,012	64	2,075	5,449
			Holidays	3,161	3,093	8,290	254	2,044	5,240

(cont'd)



**TABLE 3-E: GENERAL STATISTICS FOR MAINLINE PLAZAS
(Vehicles/Hour)**

Mainline Plaza	Dir.	30th HV	Period	Mean	Med.	Max.	Min.	Std. Dev.	85th %
35 Cermak Road	NB	5,754	AM Peak	5,297	5,359	6,137	3,600	372	5,643
			PM Peak	4,589	4,595	5,412	3,045	269	4,868
			OFF Peak	3,403	3,544	5,540	1,219	900	4,292
			Weekend	2,444	2,473	5,811	252	1,452	4,025
			Holidays	2,295	2,271	5,471	218	1,430	3,872
	SB	5,833	AM Peak	4,006	3,797	5,003	2,476	546	4,636
			PM Peak	5,273	5,310	5,979	3,791	318	5,569
			OFF Peak	3,574	3,678	5,905	1,366	1,069	4,669
			Weekend	2,454	2,442	6,106	58	1,464	4,006
			Holidays	2,303	2,180	5,830	184	1,491	3,939
36 82 nd Street	SB	6,935	AM Peak	3,671	3,511	4,555	2,335	516	4,274
			PM Peak	6,493	6,549	7,115	2,063	426	6,783
			OFF Peak	3,523	3,498	6,558	1,220	1,165	4,751
			Weekend	2,458	2,414	7,217	217	1,551	3,881
			Holidays	2,325	2,191	6,933	177	1,596	4,021
39 83 rd Street	NB	7,146	AM Peak	6,455	6,446	7,433	4,039	480	6,967
			PM Peak	4,370	4,364	5,316	3,044	264	4,636
			OFF Peak	3,352	3,446	6,263	1,285	943	4,246
			Weekend	2,450	2,408	7,181	287	1,509	3,982
			Holidays	2,328	2,294	6,252	161	1,496	3,875
41 163 rd Street	NB	4,732	AM Peak	4,359	4,374	5,483	2,812	290	4,626
			PM Peak	3,279	3,283	4,081	2,239	253	3,527
			OFF Peak	2,499	2,599	4,152	915	672	3,184
			Weekend	1,893	1,888	4,694	225	1,123	3,151
			Holidays	1,817	1,794	4,491	149	1,151	3,258
	SB	4,910	AM Peak	2,483	2,366	3,146	1,695	386	2,912
			PM Peak	4,362	4,374	4,937	1,737	307	4,613
			OFF Peak	2,556	2,589	4,611	750	737	3,245
			Weekend	1,862	1,824	5,230	174	1,131	2,983
			Holidays	1,762	1,660	5,314	135	1,178	2,813

AM Peak = Weekday 6:00 AM To 8:00 AM Except Fridays
 PM Peak = Weekday 4:00 PM To 6:00 PM Except Fridays
 OFF Peak = Weekday 5:00 AM To 10:00 PM Except AM and PM Peak Periods
 Weekend = Fridays, Saturdays, and Sundays
 Holidays = See Page 1-4 for list of Holidays.



TABLE 3-F: INDEXED MONTHLY VARIATION BY MAINLINE PLAZA

Month	Wau-kegan	Edens Spur	Touhy Avenue*	Irving Park	Cermak Road	82nd Street	83rd Street	163rd Street
January	0.83	0.86	0.86	0.90	0.90	0.90	0.90	0.87
February	0.85	0.92	0.91	0.96	0.97	0.96	0.96	0.94
March	0.92	0.94	0.99	1.00	1.01	1.00	1.00	0.99
April	0.95	0.99	1.06	1.01	1.01	1.01	1.01	1.00
May	1.00	1.00	1.11	1.04	1.06	1.06	1.06	1.06
June	1.09	1.08	1.14	1.06	1.08	1.07	1.07	1.09
July	1.19	1.10	1.02	1.02	1.04	1.03	1.04	1.07
August	1.16	1.11	1.04	1.05	1.06	1.06	1.06	1.09
September	1.05	1.03	0.98	1.00	0.97	0.97	0.97	0.98
October	1.04	1.05	1.02	1.03	1.00	1.01	1.00	1.01
November	0.97	0.99	0.98	0.99	0.98	1.00	0.99	0.99
December	0.93	0.93	0.90	0.93	0.93	0.93	0.93	0.91

TABLE 3-G: INDEXED DAILY VARIATION BY MAINLINE PLAZA

Month	Day	Wau-kegan	Edens Spur	Touhy Avenue*	Irving Park	Cermak Road	82nd Street	83rd Street	163rd Street
August	Monday	1.13	1.09	1.04	1.05	1.04	1.05	1.05	1.06
	Tuesday	1.10	1.08	1.02	1.03	1.02	1.03	1.03	1.05
	Wednesday	1.11	1.09	1.02	1.03	1.03	1.03	1.03	1.05
	Thursday	1.15	1.08	1.01	1.01	1.02	1.03	1.02	1.05
	Friday	1.14	1.10	1.03	1.03	1.04	1.05	1.03	1.09
	Saturday	1.21	1.12	1.06	1.06	1.09	1.08	1.07	1.12
	Sunday	1.31	1.16	1.06	1.11	1.12	1.09	1.14	1.13
December	Monday	0.98	0.91	0.88	0.90	0.90	0.91	0.90	0.88
	Tuesday	1.00	0.91	0.91	0.92	0.93	0.92	0.93	0.91
	Wednesday	0.98	0.97	0.95	0.97	0.98	0.98	0.98	0.97
	Thursday	0.97	0.93	0.93	0.96	0.96	0.97	0.97	0.96
	Friday	0.91	0.95	0.93	0.97	0.96	0.95	0.97	0.93
	Saturday	0.86	0.96	0.93	0.97	0.97	0.97	0.99	0.95
	Sunday	0.82	0.90	0.86	0.88	0.87	0.89	0.87	0.86

* Traffic was detoured through the Touhy Avenue plaza during the I-294 NB to I-90 WB ramp construction (March—June).

Table 3-G includes Monthly Variation



TABLE 3-H: ANNUAL TOTAL TRANSACTIONS BY TOLL PLAZA

Plaza	Plaza Code*	2011	2012	Percentage Change
20 Buckley Road	R	2,813,646	2,467,353	-12.3%
21 Waukegan	M	24,406,196	23,493,520	-3.7%
22 Townline Road	R	3,889,608	3,670,459	-5.6%
23 Half Day Road	R	3,697,802	3,629,324	-1.9%
24 Edens Spur	M	19,983,521	19,128,269	-4.3%
26 Lake Cook Road	R	5,881,155	5,649,431	-3.9%
27 Willow Road	R	5,881,364	5,623,601	-4.4%
28 Golf Road	R	6,017,659	5,763,415	-4.2%
29 Touhy Avenue**	M1	31,314,999	31,786,204	1.5%
30 Balmoral Avenue***	E1	62,633	1,883,416	-
31 O'Hare West	R1	8,392,173	7,844,416	-6.5%
32 O'Hare East	R1	7,610,667	6,169,102	-18.9%
33 Irving Park Road	M1	35,065,480	33,723,222	-3.8%
34 75th Street, Willow Springs Rd.	R	2,272,206	2,041,145	-10.2%
35 Cermak Road	M	50,337,006	47,305,060	-6.0%
36 82nd Street	M1	25,340,441	24,101,290	-4.9%
37 I-55	R	21,971,436	20,572,296	-6.4%
38 95th Street	R	5,106,758	4,849,406	-5.0%
39 83rd Street	M1	25,067,564	23,851,016	-4.9%
40 159th Street	R	2,995,506	3,117,445	4.1%
41 163rd Street	M	37,616,153	35,735,169	-5.0%
43 I-80 Westbound	A	12,068,688	12,323,045	2.1%
45 I-80 Eastbound	A	11,787,773	11,999,275	1.8%
47 Halsted Street	R	8,141,141	7,603,418	-6.6%
Tri-State Total		357,721,575	344,330,297	-3.7%

* M=Mainline / R=Ramp / A=Attended Ramp Plaza / E=Electronic Toll Collection Only Ramp
1=Toll Collected in One Direction Only

** Detoured traffic used the Touhy Avenue plaza during NB I-294 to WB I-90 ramp construction (March - June 2012).

*** Plaza 30 opened on December 14, 2011.



TABLE 3-I: AVERAGE DAILY TRAFFIC DATA

Year	Average Daily Total			Average Trip
	Vehicles	Vehicle Miles	Transactions	Length (Miles)
1959	42,944	1,074,421	87,977	25.02
1960	53,665	1,423,119	114,591	26.52
1961	63,040	1,508,414	113,413	23.93
1962	79,567	1,716,653	149,996	21.57
1963	81,865	1,538,064	135,872	18.79
1964	83,177	1,576,375	140,729	18.95
1965	96,141	1,791,966	161,958	18.64
1966	104,898	2,070,944	189,068	19.74
1967	113,248	2,264,510	211,941	20.00
1968	124,197	2,499,952	255,161	20.13
1969	145,335	2,795,118	285,279	19.23
1970	150,204	2,993,741	305,965	19.93
1971	165,910	3,324,444	340,539	20.04
1972	177,740	3,435,183	352,056	19.33
1973	196,462	3,684,032	386,527	18.75
1974	206,074	3,814,440	404,858	18.51
1975	212,313	3,815,435	407,611	17.97
1976	234,136	4,147,527	442,435	17.71
1977	252,032	4,472,743	475,766	17.75
1978	268,655	4,748,560	504,534	17.68
1979	274,714	4,870,270	520,258	17.73
1980	264,698	4,804,154	508,555	18.15
1981	279,965	4,905,922	522,890	17.52
1982	281,782	4,818,745	519,152	17.10
1983	291,652	5,001,519	532,111	17.15
1984	310,008	5,493,171	583,129	17.72
1985	327,277	5,660,998	603,292	17.30
1986	348,651	6,227,866	654,517	17.86
1987	367,191	6,233,335	685,226	16.98
1988	396,711	7,132,315	749,395	17.98
1989	410,352	7,364,825	771,395	17.95
1990	425,089	7,501,631	779,065	17.65
1991	478,355	7,607,215	797,157	15.90
1992	494,963	7,283,706	781,630	14.72
1993	499,598	7,205,338	782,631	14.42
1994	491,071	8,254,734	859,181	16.81
1995	520,320	8,814,694	916,329	16.94
1996	540,460	9,090,414	945,831	16.82
1997	562,300	9,257,833	971,481	16.46
1998	577,930	9,408,676	975,821	16.28
1999	576,220	9,404,524	893,630	16.32
2000	590,900	9,632,552	916,723	16.30
2001	601,820	9,775,171	933,313	16.24
2002	615,200	10,263,261	965,408	16.68
2003	626,950	10,515,023	989,952	16.77
2004	634,390	10,611,992	1,003,291	16.73
2005	594,220	9,982,878	936,432	16.80
2006	537,400	9,956,325	927,615	18.53
2007	563,600	10,132,520	964,388	17.98
2008	581,370	9,101,117	894,275	15.65
2009	578,140	8,992,194	886,512	15.55
2010	624,360	9,979,253	955,841	15.98
2011	638,210	10,128,377	982,468	15.87
2012	628,660	9,752,805	940,793	15.51



FIGURE 3-B



FIGURE 3-D

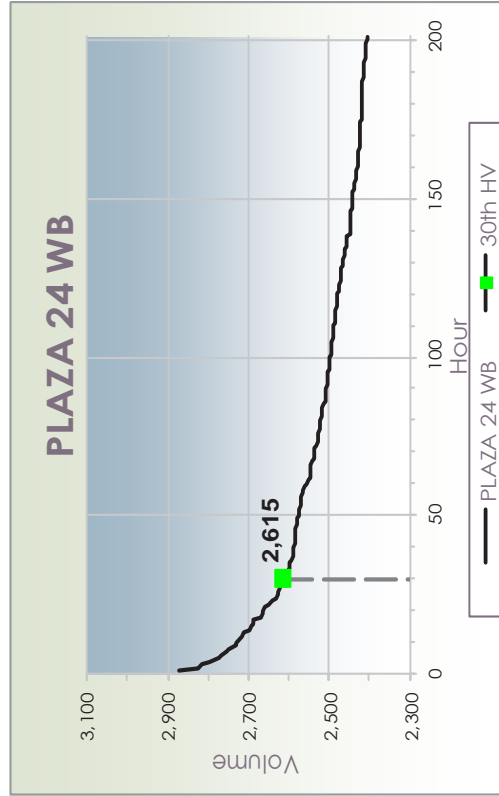

FIGURE 3-A

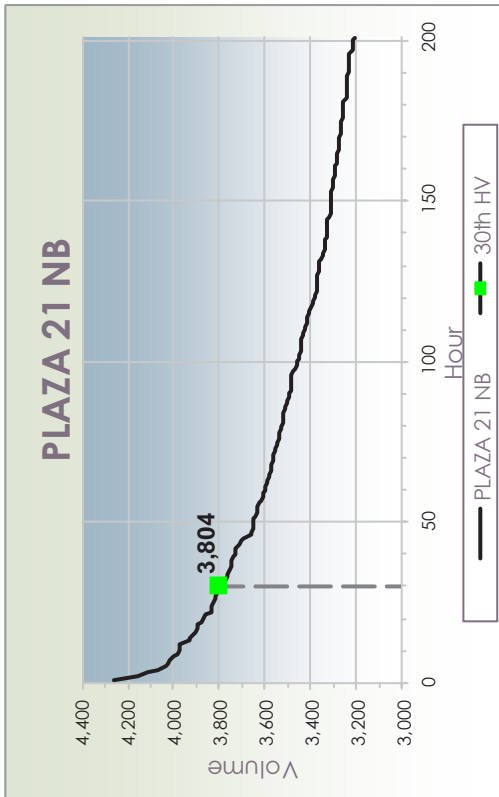
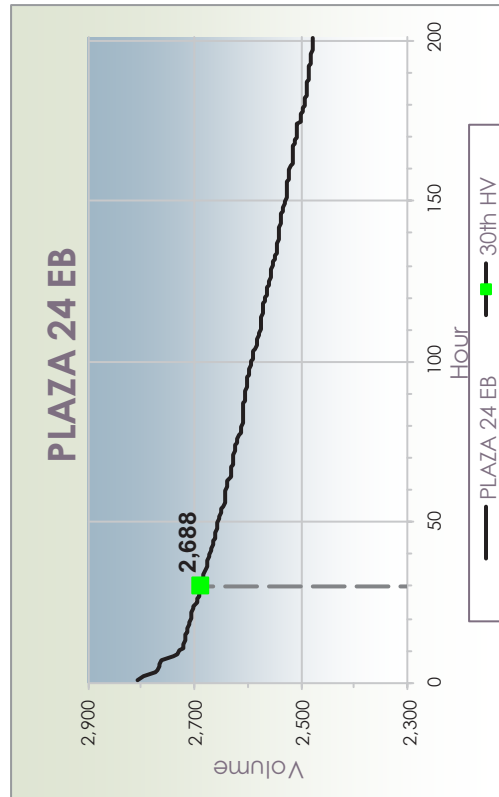

FIGURE 3-C



MAINLINE PLAZA HIGHEST HOURLY VOLUME



FIGURE 3-E

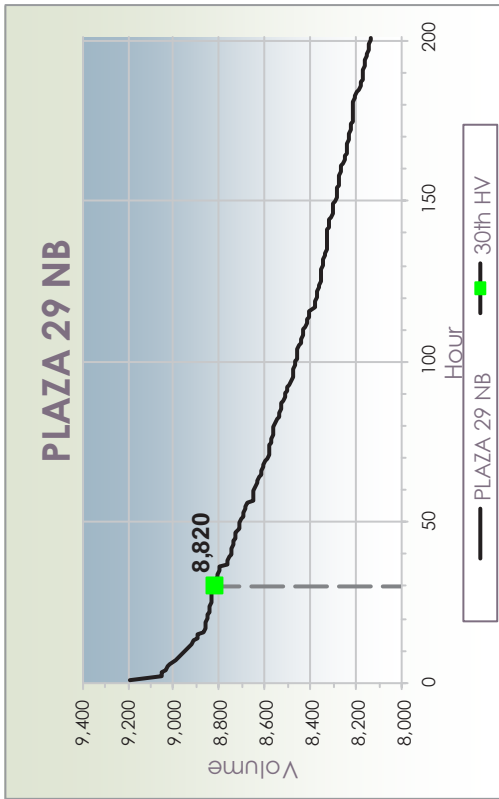

FIGURE 3-F

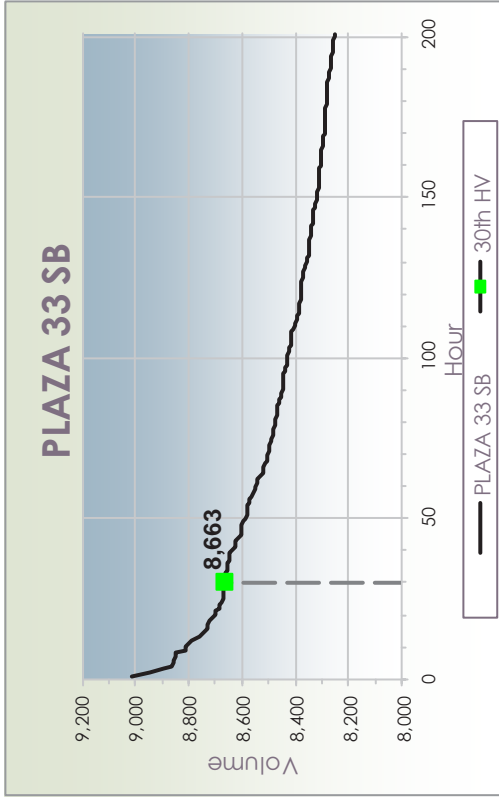

FIGURE 3-G

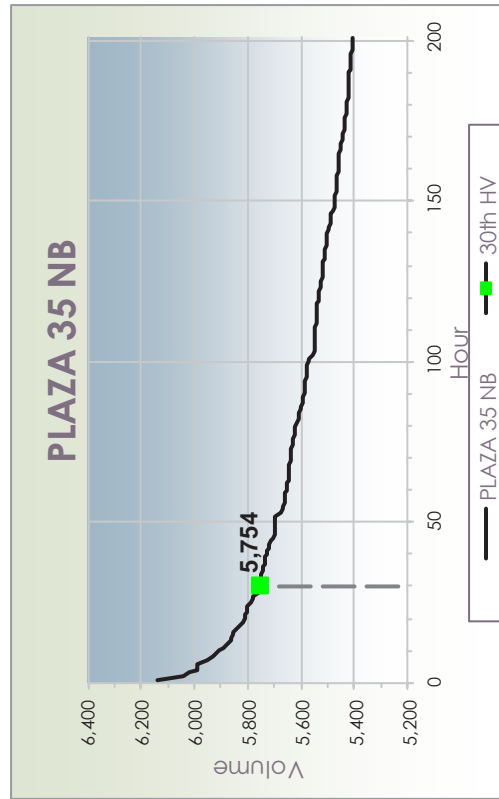
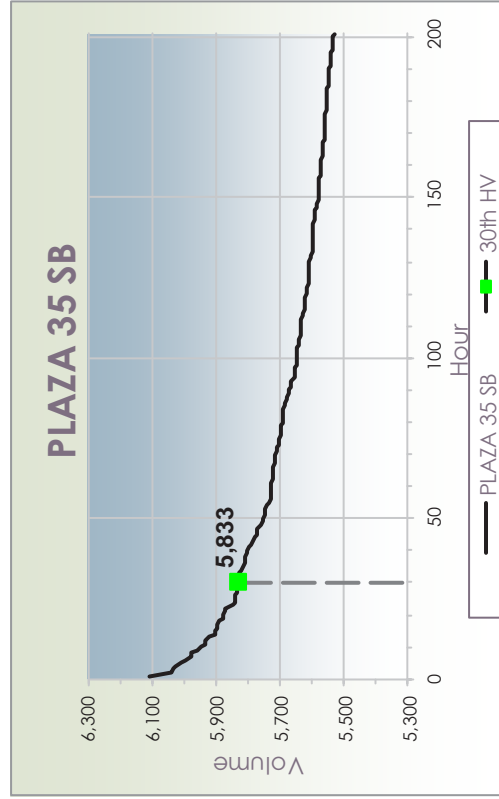

FIGURE 3-H



MAINLINE PLAZA HIGHEST HOURLY VOLUME



FIGURE 3-I



FIGURE 3-J

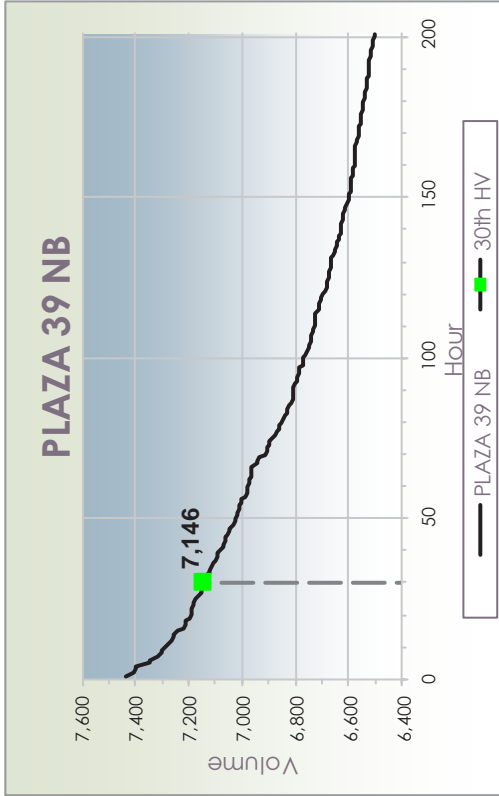

FIGURE 3-K

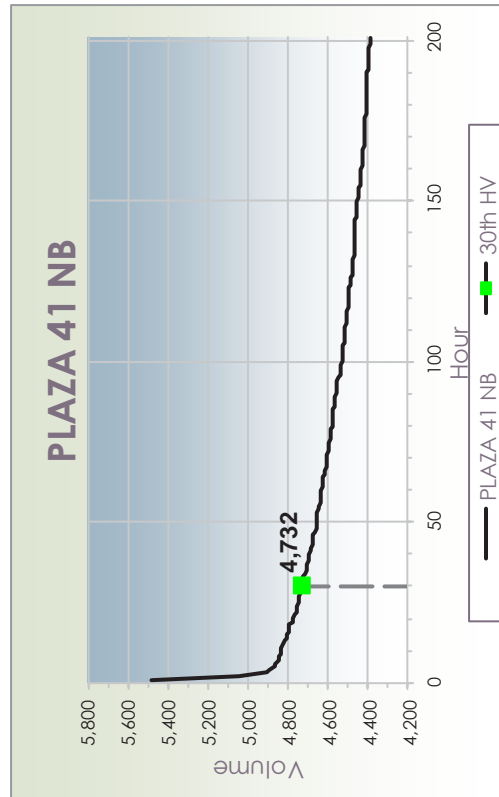
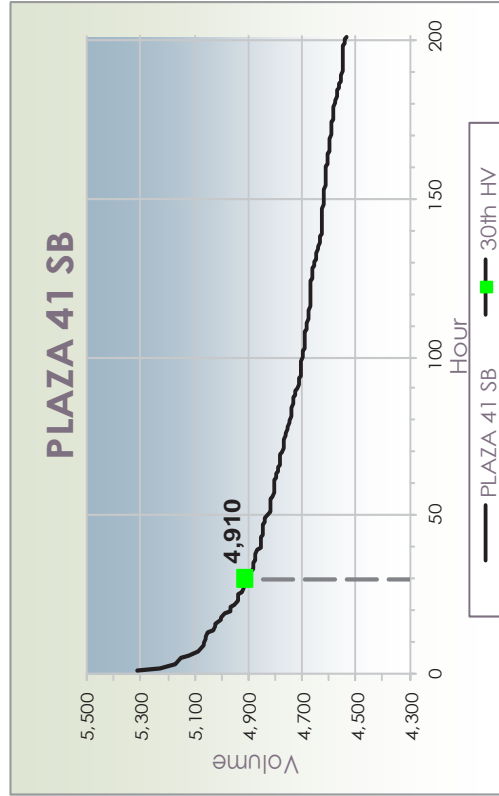

FIGURE 3-L



MAINLINE PLAZA HIGHEST HOURLY VOLUME



FIGURE 3-M

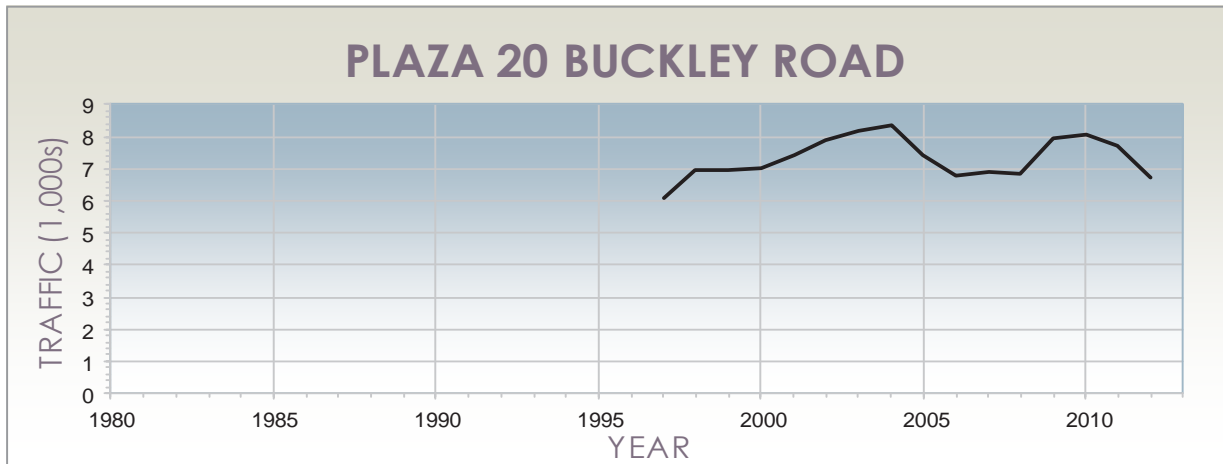

FIGURE 3-N

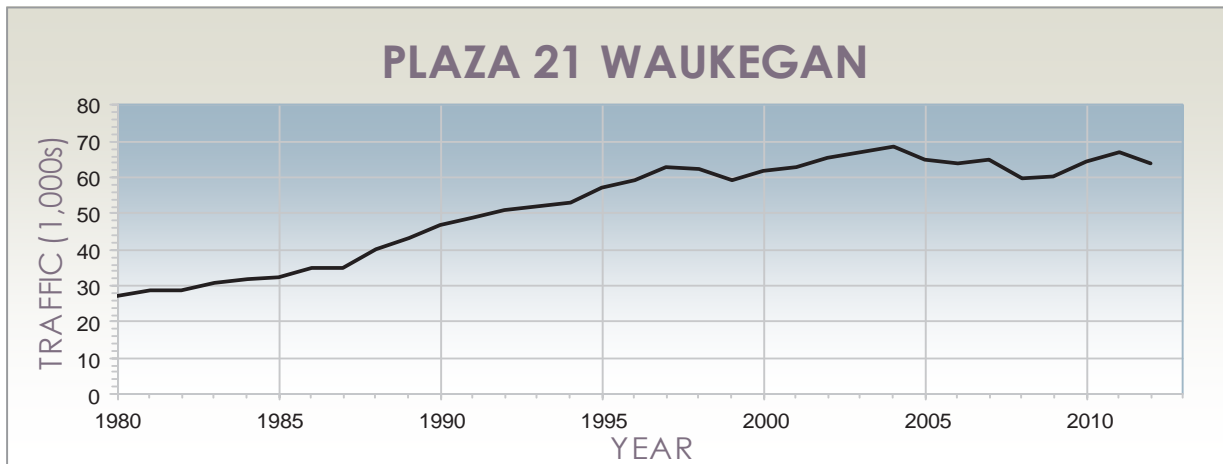
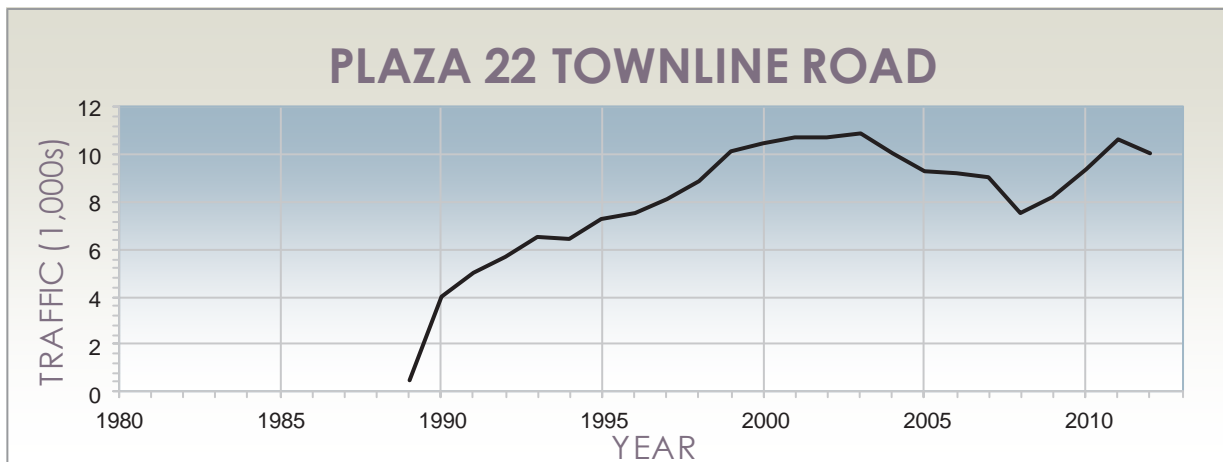

FIGURE 3-O



AVERAGE DAILY TRAFFIC TRENDS



FIGURE 3-P

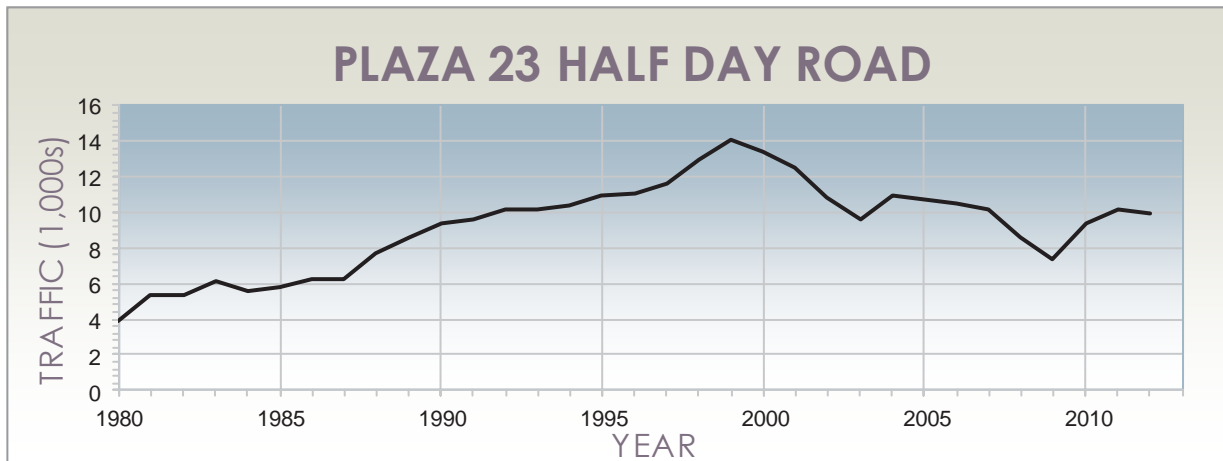

FIGURE 3-Q

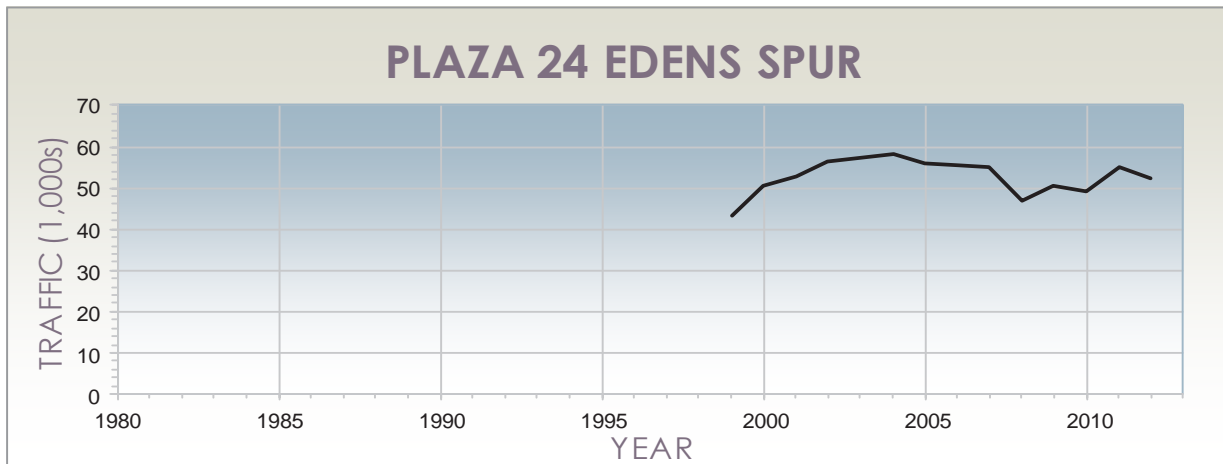
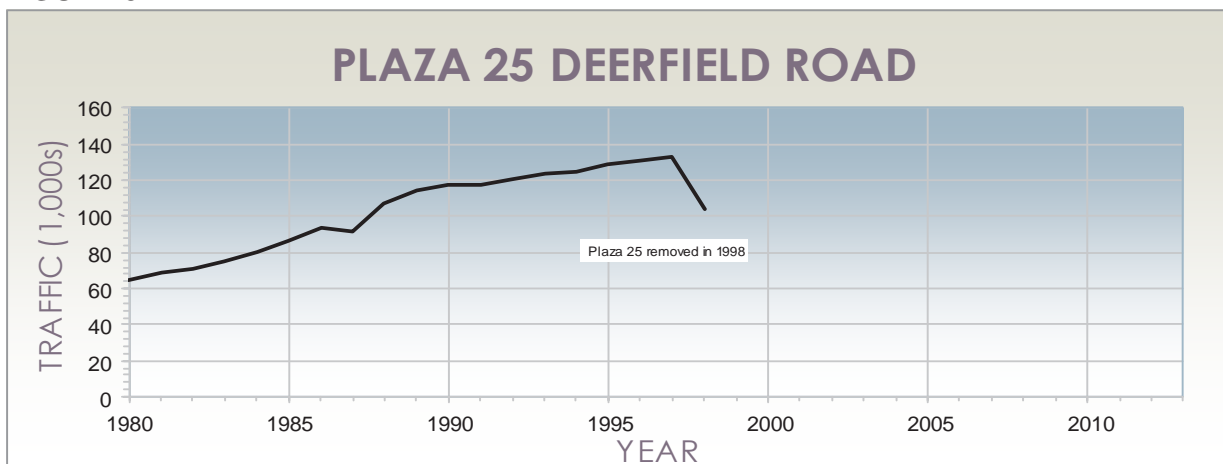

FIGURE 3-R



AVERAGE DAILY TRAFFIC TRENDS



FIGURE 3-S

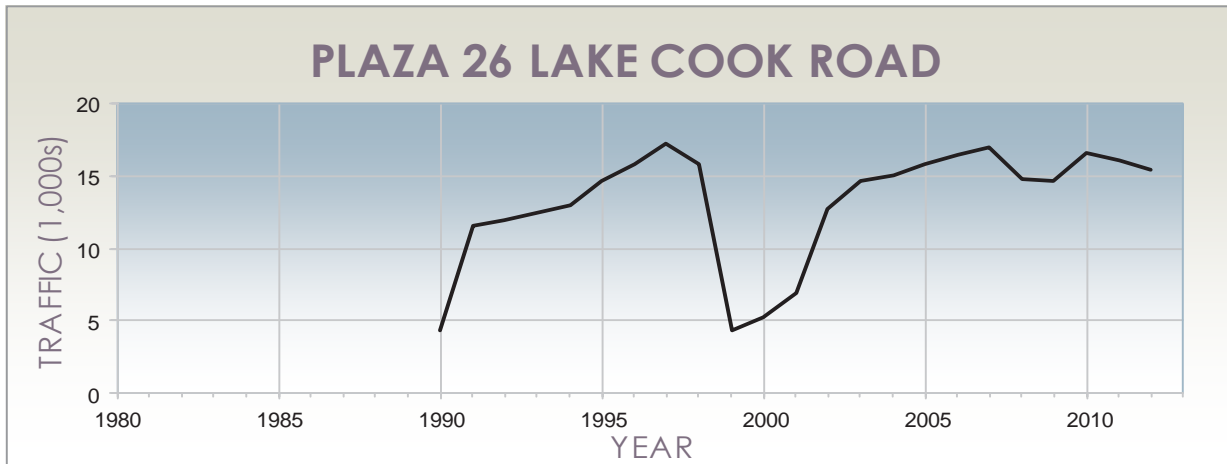

FIGURE 3-T

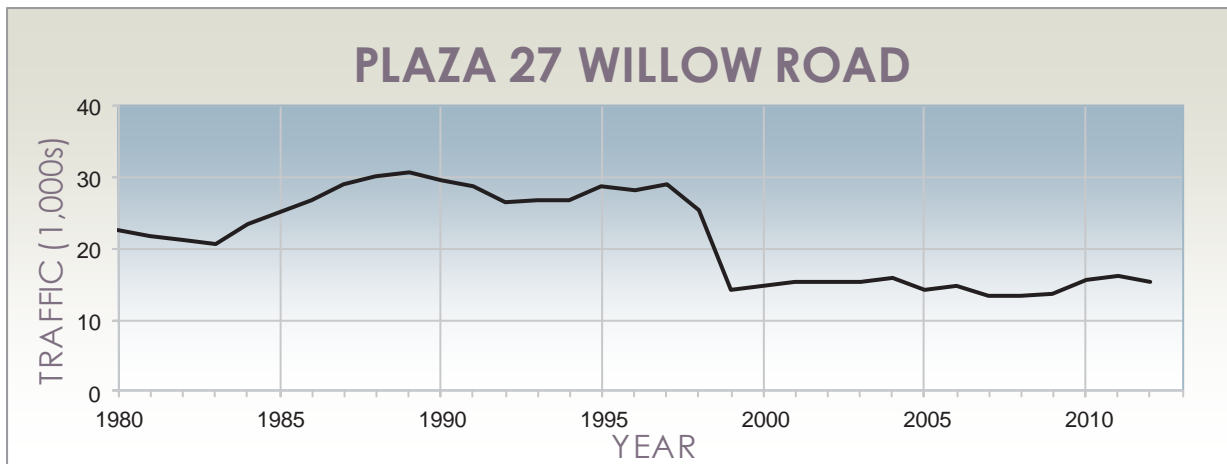
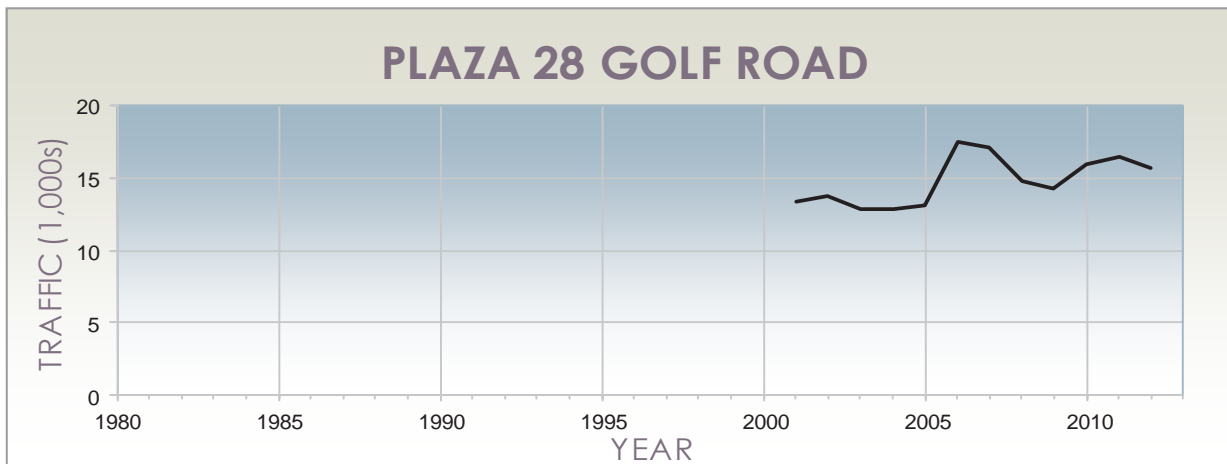

FIGURE 3-U



AVERAGE DAILY TRAFFIC TRENDS



FIGURE 3-V

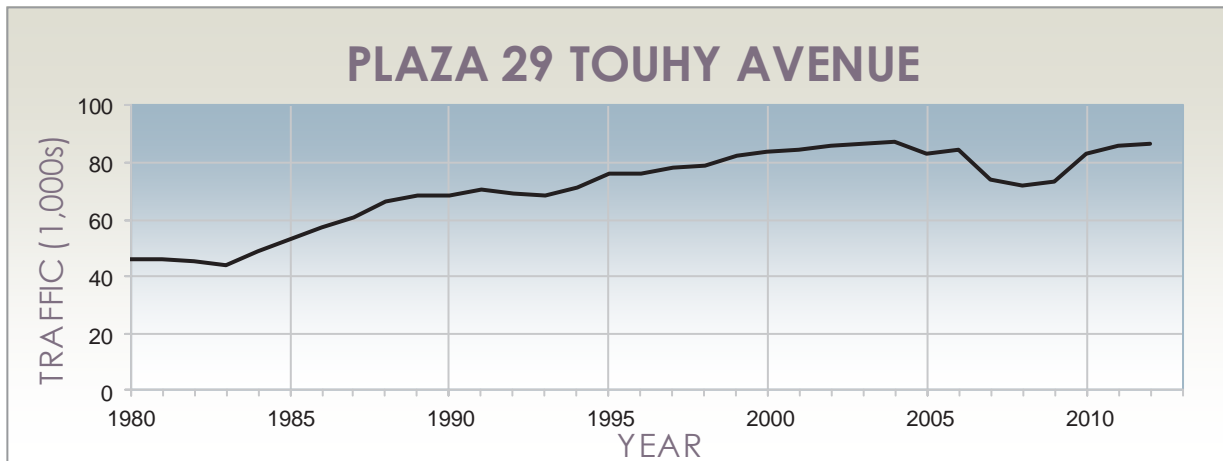

FIGURE 3-W

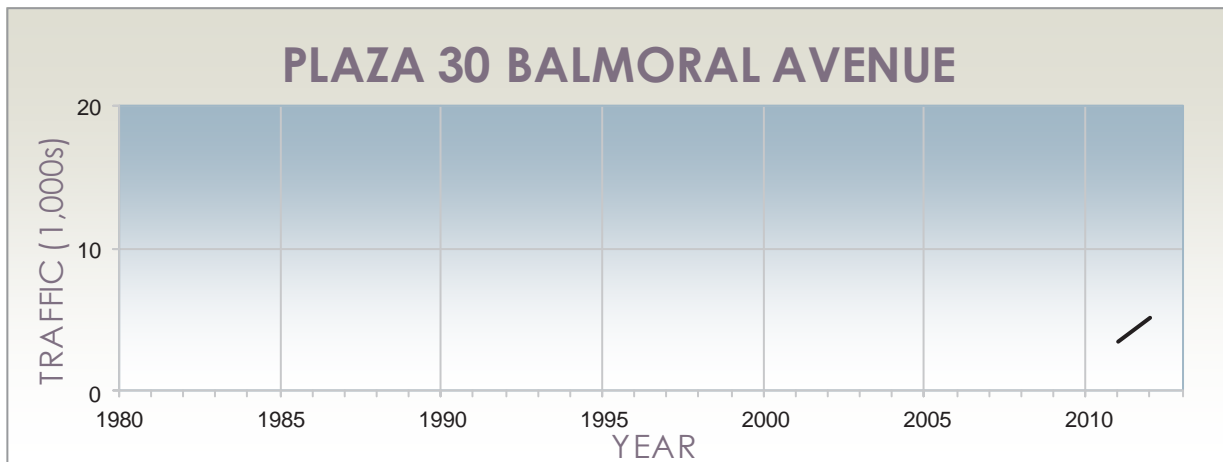
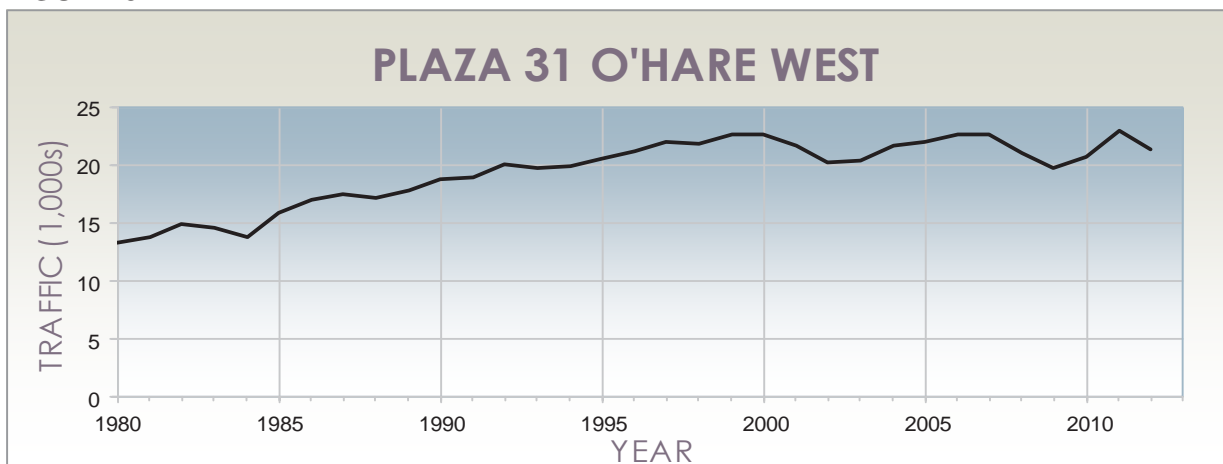

FIGURE 3-X



AVERAGE DAILY TRAFFIC TRENDS



FIGURE 3-Y

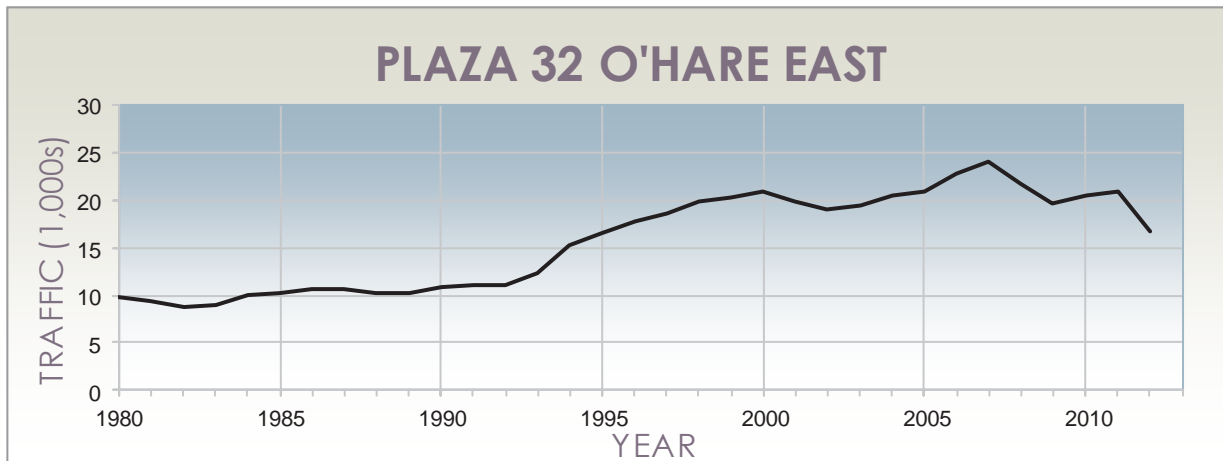

FIGURE 3-Z

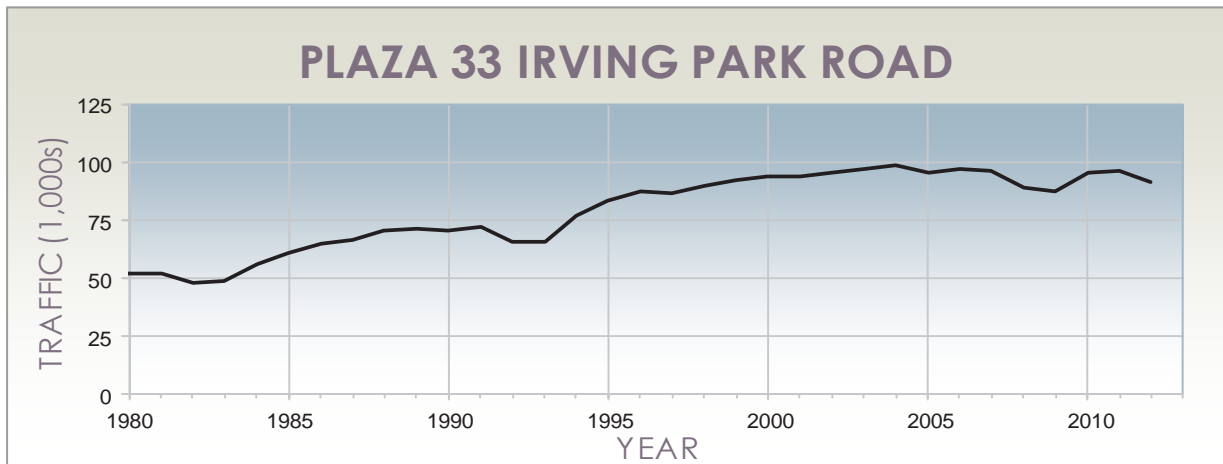
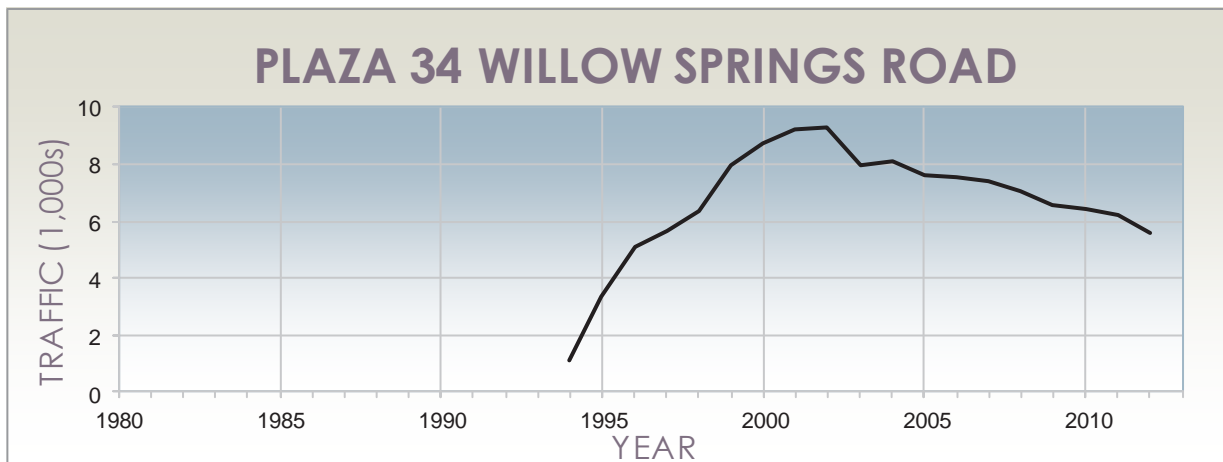

FIGURE 3-AA



AVERAGE DAILY TRAFFIC TRENDS



FIGURE 3-AB

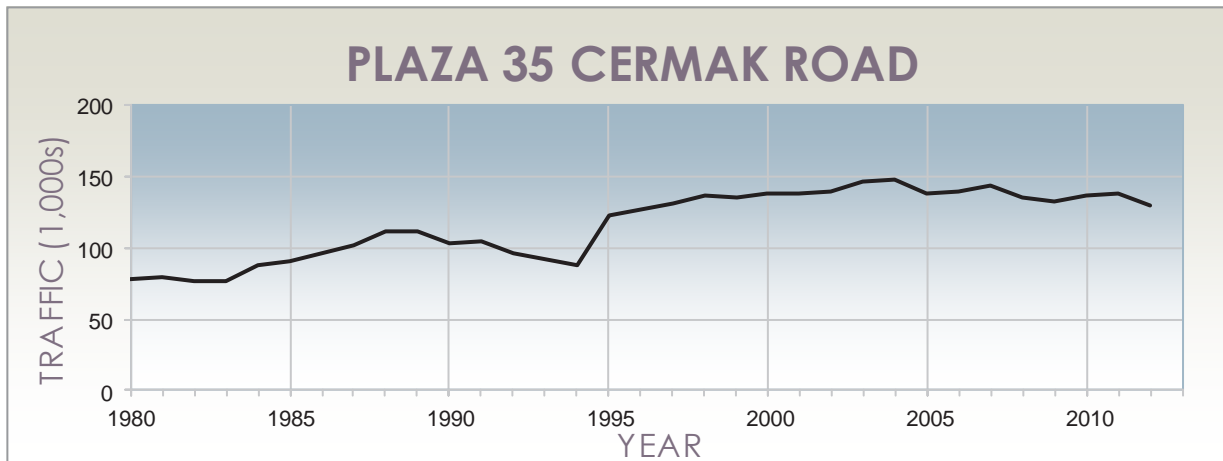

FIGURE 3-AC

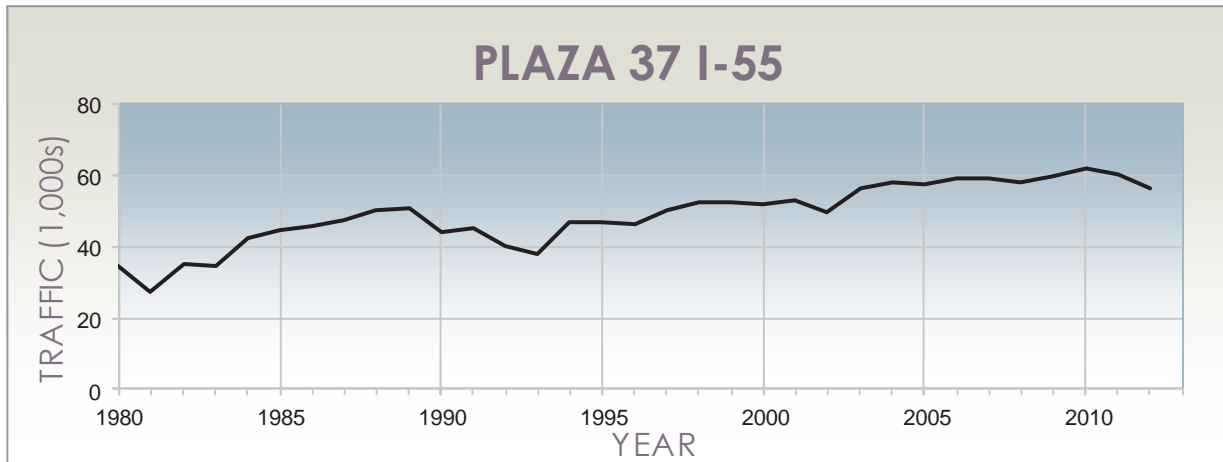
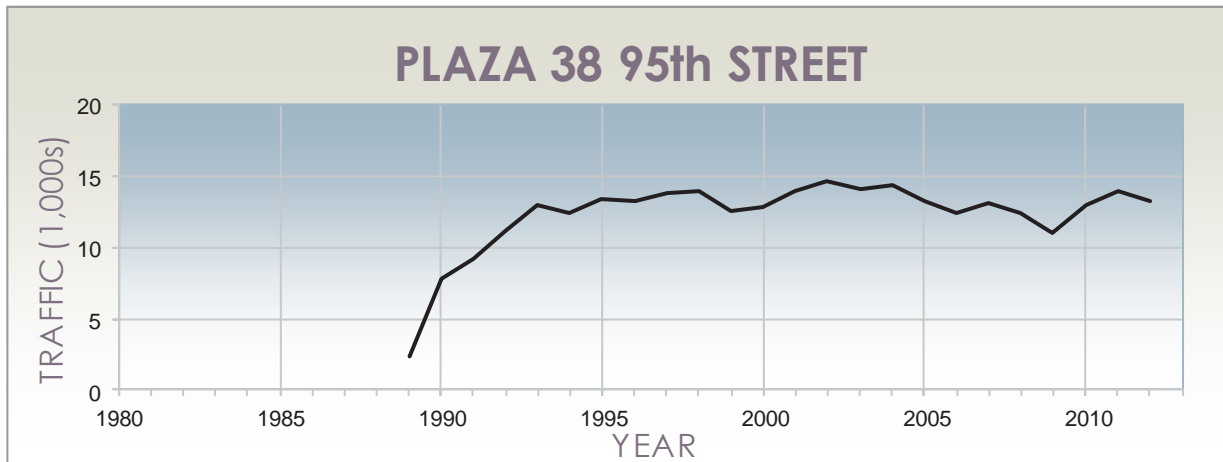

FIGURE 3-AD



AVERAGE DAILY TRAFFIC TRENDS



FIGURE 3-AE

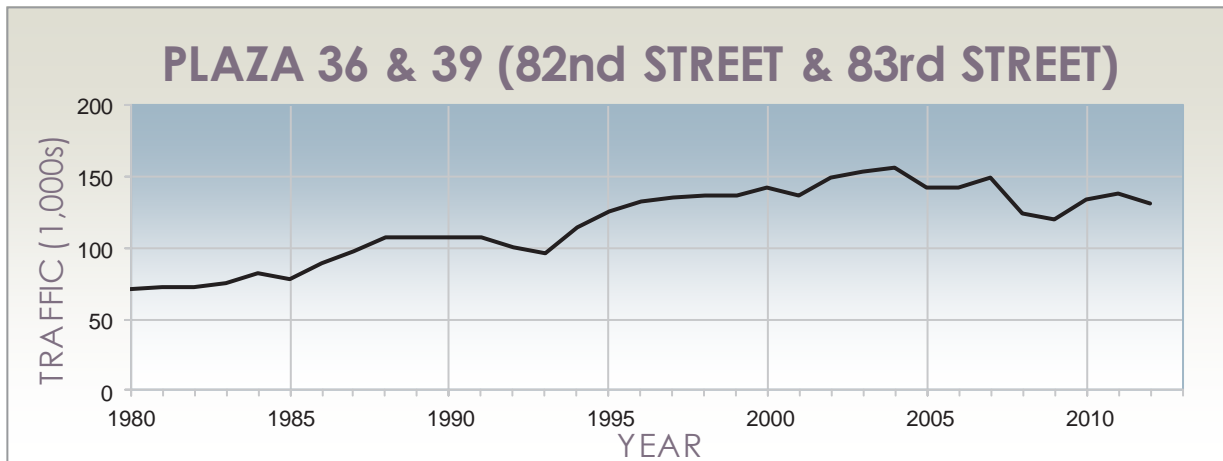

FIGURE 3-AF

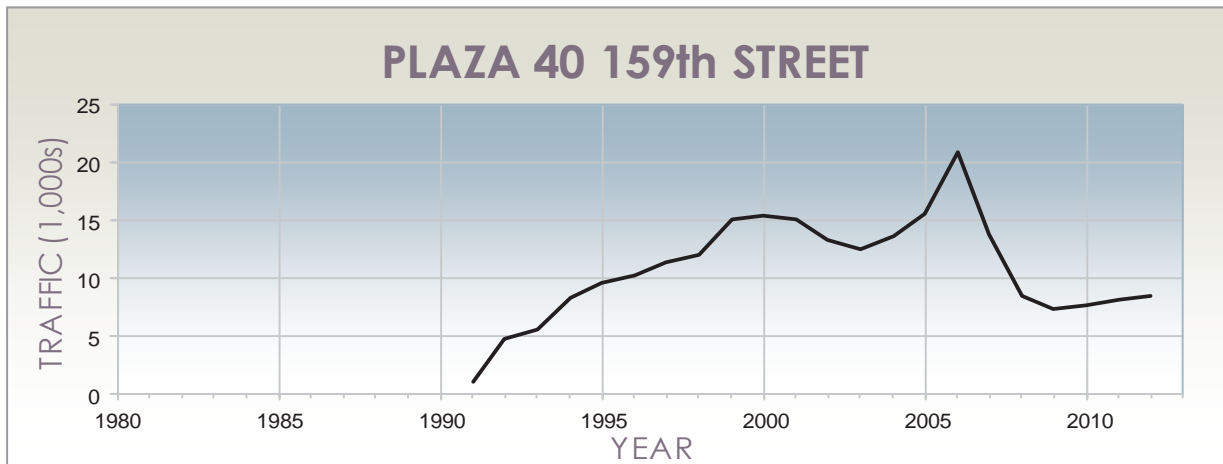
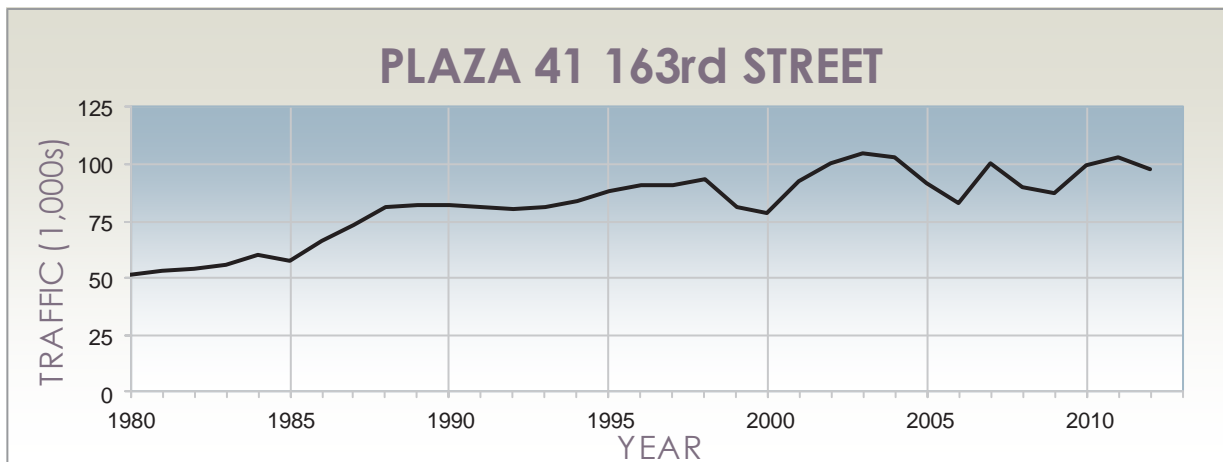

FIGURE 3-AG



AVERAGE DAILY TRAFFIC TRENDS



FIGURE 3-AH

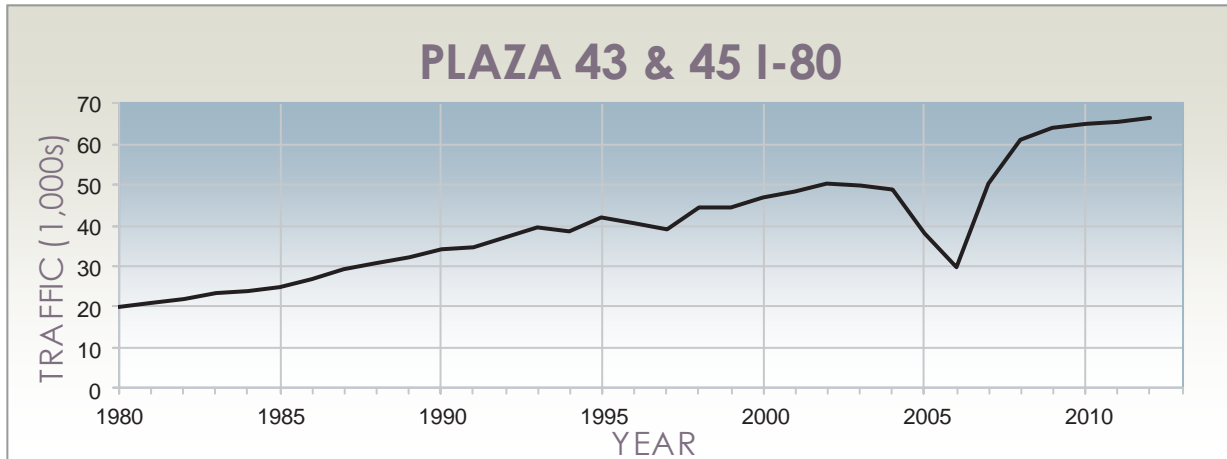
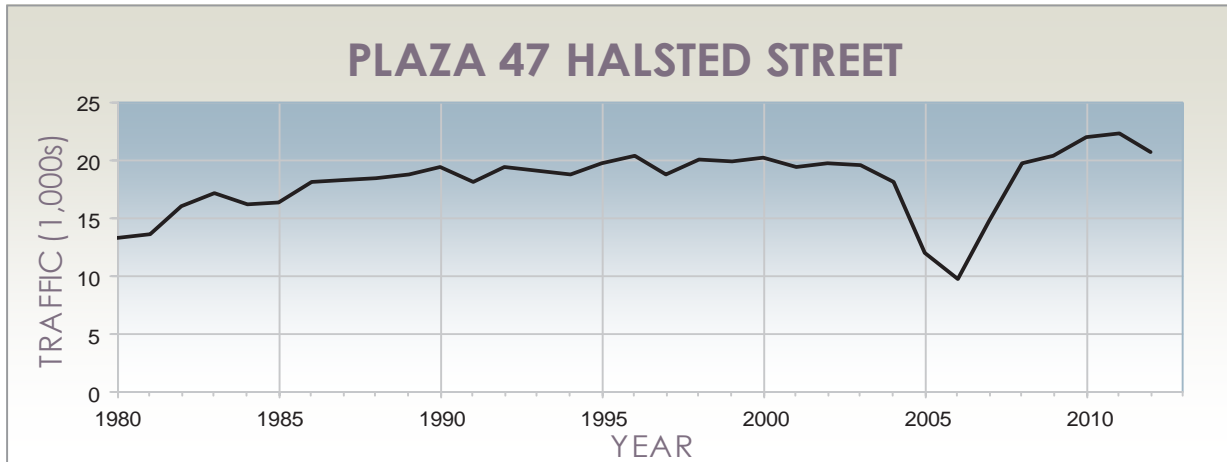

FIGURE 3-AI



AVERAGE DAILY TRAFFIC TRENDS



This Page Is Intentionally Left Blank

Section 4 Tab





SECTION 4

Reagan Memorial Tollway

TABULATIONS TABLE

	PAGE
4-A Average Daily Traffic Volumes Between Interchanges 1980 – 2012 (Westbound)	4-4
4-B Average Daily Vehicle Miles Traveled Between Interchanges 1980 – 2012 (Westbound)	4-5
4-C Average Daily Traffic Volumes Between Interchanges 1980 – 2012 (Eastbound)	4-6
4-D Average Daily Vehicle Miles Traveled Between Interchanges 1980 – 2012 (Eastbound)	4-7
4-E General Statistics for Mainline Plazas	4-8
4-F Indexed Monthly Variation by Mainline Plaza	4-10
4-G Indexed Daily Variation by Mainline Plaza	4-10
4-H Annual Total Transactions by Toll Plaza	4-11
4-I Average Daily Traffic Data	4-12

ILLUSTRATIONS FIGURE

	PAGE
4-A Mainline Plaza Highest Hourly Volume Plaza 51 WB	4-13
4-B Mainline Plaza Highest Hourly Volume Plaza 52 EB	4-13
4-C Mainline Plaza Highest Hourly Volume Plaza 61 EB	4-13
4-D Mainline Plaza Highest Hourly Volume Plaza 61 WB	4-13
4-E Mainline Plaza Highest Hourly Volume Plaza 66 EB	4-14
4-F Mainline Plaza Highest Hourly Volume Plaza 66 WB	4-14
4-G Mainline Plaza Highest Hourly Volume Plaza 69 EB	4-14
4-H Mainline Plaza Highest Hourly Volume Plaza 69 WB	4-14
4-I Average Daily Traffic Trends Plaza 51 York Road	4-15
4-J Average Daily Traffic Trends Plaza 52 Meyers Road	4-15
4-K Average Daily Traffic Trends Plaza 53 Spring Road	4-15
4-L Average Daily Traffic Trends Plaza 54 Illinois 83	4-16
4-M Average Daily Traffic Trends Plaza 55 Midwest Road	4-16
4-N Average Daily Traffic Trends Plaza 56 Highland Avenue	4-16
4-O Average Daily Traffic Trends Plaza 57 Naperville Road	4-17



SECTION 4 Reagan Memorial Tollway

ILLUSTRATIONS (CONTINUED) FIGURE

PAGE

4-V	Average Daily Traffic Trends Plaza 65 Peace Road	4-19
4-W	Average Daily Traffic Trends Plaza 66 DeKalb	4-19
4-X	Average Daily Traffic Trends Plaza 67 Annie Glidden Road	4-20
4-Y	Average Daily Traffic Trends Plaza 69 Dixon	4-20
4-Z	Average Daily Traffic Trends Plaza 70 Illinois 26 West	4-20
4-AA	Average Daily Traffic Trends Plaza 71 Illinois 26 East	4-21



This Page Is Intentionally Left Blank



TABLE 4-A: AVERAGE DAILY TRAFFIC VOLUMES BETWEEN INTERCHANGES 1980-2012 (WESTBOUND)

Location	Mile Post	Miles Btwn. Int.	ADT 1980	Average Annual Percent Change	ADT 1990	Average Annual Percent Change	ADT 2000	Average Annual Percent Change	ADT 2010	Average Annual Percent Change	ADT 2012
Eisenhower Expy (I-290)	140.4										
		0.4	18,400	7.3	37,260	3.1	50,620	-0.7	47,270	6.8	53,880
Reagan Mem. Twy (I-88)	140.0										
		1.1	24,050	5.4	40,610	3.6	57,780	2.0	70,480	2.3	73,760
Harzer (York) Rd.	138.9										
		0.2	24,690	5.5	42,130	3.6	60,170	1.8	71,920	2.3	75,200
Tollway South Leg	138.7										
Plaza 51	138.1	0.9	31,790	5.7	55,350	3.1	75,420	0.4	78,160	0.0	78,160
Spring Rd. (PI53)	137.8										
		0.7	31,670	5.9	55,970	3.1	76,280	0.3	78,570	2.1	81,900
Kingery Hwy (I183)	137.1										
		0.7	30,050	5.7	52,230	3.2	71,470	0.4	74,580	2.2	77,900
Midwest Rd. (PI55)	136.4										
Plaza 52	135.1	2.1	28,230	6.0	50,500	3.5	71,470	0.4	74,580	2.2	77,900
Highland Ave. (PI56)	134.3										
		1.1	21,780	8.2	47,890	3.7	69,030	0.5	72,210	2.0	75,180
Veterans Mem. Twy (E. Int)	133.2										
		1.9	21,780	7.8	46,120	3.3	64,090	-0.2	62,720	-0.3	62,390
Veterans Mem. Twy (W. Int)	131.3										
		1.3	21,780	9.4	53,340	3.7	76,590	0.6	81,220	-0.2	80,830
IL53	130.0										
		2.4	15,840	11.0	44,890	4.2	68,020	0.8	73,810	-0.3	73,400
Naperville Rd. (PI57)	127.6										
		2.4	13,130	10.1	34,280	5.7	59,400	1.4	68,510	-0.9	67,240
Winfield Rd. (PI58)	125.2										
		1.9	13,130	10.1	34,280	3.8	49,840	2.4	63,030	0.4	63,520
IL59	123.3										
		1.9	8,260	10.4	22,160	4.1	33,140	4.3	50,400	-0.3	50,050
Eola Rd. (PI60)	121.4										
		2.2	8,260	10.4	22,160	4.1	33,140	3.9	48,470	-0.5	47,990
Farnsworth Ave. (PI59)	119.2										
Plaza 61	117.8	2.2	6,870	9.4	16,900	4.0	24,970	4.4	38,250	-0.7	37,700
IL31 (PI63)	117.0										
		2.6	5,340	9.6	13,320	3.6	18,990	5.3	31,690	-1.1	31,020
Orchard Rd. (PI64)	114.4										
		1.1	5,340	7.9	11,420	2.8	15,110	3.9	22,100	-2.5	21,020
IL56	113.3										
		4.0	3,170	7.7	6,680	3.8	9,710	3.5	13,740	-4.3	12,590
IL47	109.3										
		15.3	3,640	7.4	7,440	4.0	11,020	3.4	15,350	-3.9	14,180
Peace Rd. (PI65)	94.0										
		0.7	2,550	7.4	5,230	5.2	8,680	3.7	12,440	-7.2	10,720
DeKalb Oasis	93.3										
		1.9	2,550	7.4	5,230	5.2	8,680	3.7	12,440	-7.2	10,720
Annie Glidden Rd. (PI67)	91.4										
Plaza 66	86.2	12.9	2,010	8.3	4,480	5.4	7,550	2.3	9,480	-3.8	8,770
Interstate 39	78.5										
		2.4	2,010	8.4	4,500	4.8	7,200	1.8	8,610	-2.7	8,150
US51 (I1251)	76.1										
Plaza 69	56.4	22.2	2,350	5.5	4,030	5.0	6,570	1.3	7,460	-2.6	7,070
IL26 (Dixon)	53.9										
		9.7	2,510	4.3	3,820	4.5	5,920	2.0	7,220	-2.6	6,850
US30 West Terminus	44.2										
Subtotal		96.2	351,180	7.5	722,220	3.7	1,040,860	1.4	1,194,710	0.6	1,208,090
Reagan Connector		1.4	7,100	6.4	13,220	1.4	15,250	2.4	19,260	-2.1	18,460
Grand Total		97.6	358,280	7.5	735,440	3.7	1,056,110	1.4	1,213,970	0.5	1,226,550



TABLE 4-B: AVERAGE DAILY VEHICLE MILES TRAVELED BETWEEN INTERCHANGES 1980-2012 (WESTBOUND)

Location	Mile Post	Miles Btwn. Int.	Daily Vehicle Miles				
			1980	1990	2000	2010	2012
Eisenhower Expy (I-290)	140.4						
		0.4	7,360	14,904	20,248	18,908	21,552
Reagan Mem. Twy (I-88)	140.0						
		1.1	26,455	44,671	63,558	77,528	81,136
Harger (York) Rd.	138.9						
		0.2	4,938	8,426	12,034	14,384	15,040
Tollway South Leg Plaza 51	138.7						
	138.1	0.9	28,611	49,815	67,878	70,344	70,344
Spring Rd. (PI53)	137.8						
		0.7	22,169	39,179	53,396	54,999	57,330
Kincaery Hwy (IL83)	137.1						
		0.7	21,035	36,561	50,029	52,206	54,530
Midwest Rd. (PI55) Plaza 52	136.4						
	135.1	2.1	59,283	106,050	150,087	156,618	163,590
Highland Ave. (PI56)	134.3						
		1.1	23,958	52,679	75,933	79,431	82,698
Veterans Mem. Twy (E. Int)	133.2						
		1.9	41,382	87,628	121,771	119,168	118,541
Veterans Mem. Twy (W. Int)	131.3						
		1.3	28,314	69,342	99,567	105,586	105,079
IL53	130.0						
		2.4	38,016	107,736	163,248	177,144	176,160
Naperville Rd. (PI57)	127.6						
		2.4	31,512	82,272	142,560	164,424	161,376
Winfield Rd. (PI58)	125.2						
		1.9	24,947	65,132	94,696	119,757	120,688
IL59	123.3						
		1.9	15,694	42,104	62,966	95,760	95,095
Fola Rd. (PI60)	120.5						
		2.2	18,172	48,752	72,908	106,634	105,578
Farnsworth Ave. (PI59) Plaza 61	119.2						
	117.8	2.2	15,114	37,180	54,934	84,150	82,940
IL31 (PI63)	117.0						
		2.6	13,884	34,632	49,374	82,394	80,652
Orchard Rd. (PI64)	114.4						
		1.1	5,874	12,562	16,621	24,310	23,122
IL56	113.3						
		4.0	12,680	26,720	38,840	54,960	50,360
IL47	109.3						
		15.3	55,692	113,832	168,606	234,855	216,954
Peace Rd. (PI65)	94.0						
		0.7	1,785	3,661	6,076	8,708	7,504
DeKalb Oasis	93.3						
		1.9	4,845	9,937	16,492	23,636	20,368
Annie Glidden Rd. (PI67) Plaza 66	91.4						
	86.2	12.9	25,929	57,792	97,395	122,292	113,133
Interstate 39	78.5						
		2.4	4,824	10,800	17,280	20,664	19,560
US51 (IL251) Plaza 69	76.1						
	56.4	22.2	52,170	89,466	145,854	165,612	156,954
IL26 (Dixon)	53.9						
		9.7	24,347	37,054	57,424	70,034	66,445
US30 West Terminus	44.2						
Subtotal		96.2	608,990	1,288,887	1,919,775	2,304,506	2,266,729
Reagan Connector		1.4	9,940	18,508	21,350	26,964	25,844
Grand Total		97.6	618,930	1,307,395	1,941,125	2,331,470	2,292,573



TABLE 4-C: AVERAGE DAILY TRAFFIC VOLUMES BETWEEN INTERCHANGES 1980-2012 (EASTBOUND)

Location	Mile Post	Miles Btwn. Int.	ADT 1980	Average Annual Percent Change	ADT 1990	Average Annual Percent Change	ADT 2000	Average Annual Percent Change	ADT 2010	Average Annual Percent Change	ADT 2012
Eisenhower Expv (I-290)	140.4										
		0.4	15,290	6.7	29,300	4.3	44,490	0.7	47,580	1.7	49,230
Reagan Memorial Twy (I-88)	140.0										
		1.1	21,750	5.0	35,360	4.2	53,170	0.3	54,630	3.6	58,600
Harger (York) Rd.	138.9										
		0.2	21,750	5.0	35,360	4.2	53,170	0.3	54,630	3.6	58,600
Reagan Connector	138.7										
PLA7A 51	138.1	0.9	30,390	5.6	52,500	3.1	71,030	0.8	76,930	2.3	80,500
Spring Rd.	137.8										
		0.7	30,390	5.6	52,500	3.1	71,030	0.8	76,930	2.3	80,500
IL83 (PL54)	137.1										
		0.7	27,930	5.5	47,610	3.0	64,000	0.8	69,510	2.2	72,670
Midwest Rd. (PL55)	136.4										
Plaza 52	135.1	2.1	28,740	5.7	50,050	3.4	70,000	0.6	73,950	2.2	77,300
Highland Ave. (PL56)	134.3										
		1.1	22,500	7.5	46,280	4.0	68,610	0.8	74,300	2.2	77,560
Veterans Mem. Twy (E. Int)	133.2										
		1.9	22,500	8.6	51,280	4.4	78,680	0.2	80,450	0.4	81,160
Veterans Mem. Twy (W. Int)	131.3										
		1.3	22,500	8.9	52,980	3.9	77,900	0.4	81,280	1.0	82,970
IL53	130.0										
		2.4	16,500	10.5	44,710	4.4	68,790	0.9	74,980	1.0	76,520
Naperville Rd.	127.6										
		2.4	13,620	9.8	34,550	5.5	59,040	1.7	70,040	-1.5	67,980
Winfield Rd. (PL58)	125.2										
		1.9	13,620	9.8	34,550	3.9	50,840	2.5	64,810	-1.8	62,530
IL59	123.3										
		1.9	8,740	10.0	22,610	4.1	33,790	4.3	51,490	-0.1	51,350
Fola Rd. (PL60)	121.4										
		2.2	8,740	10.0	22,610	4.1	33,790	3.7	48,630	-0.6	48,030
Farnsworth Ave. (PL59)	119.2										
PLA7A 61	117.8	2.2	7,170	9.1	17,180	4.0	25,370	4.4	38,890	-1.1	38,060
IL31 (PL63)	117.0										
		2.6	5,500	9.4	13,560	3.5	19,170	5.2	31,930	-1.4	31,020
Orchard Rd. (PL64)	114.4										
		1.1	5,500	7.7	11,510	3.5	16,160	3.1	21,860	-2.8	20,670
IL56	113.3										
		4.0	3,110	8.0	6,690	3.8	9,720	3.4	13,580	-4.6	12,360
IL47	109.3										
		15.3	3,570	7.6	7,400	4.0	10,990	3.2	15,090	-4.1	13,870
Peace Rd. (PL65)	94.0										
		0.7	2,620	7.4	5,370	5.1	8,800	3.4	12,270	-8.0	10,380
DeKalb Oasis	93.3										
		1.9	2,620	7.4	5,370	5.1	8,800	3.4	12,270	-8.0	10,380
Annie Glidden Rd. (PL67)	91.4										
PLA7A 66	86.2	12.9	2,050	8.0	4,440	5.4	7,530	2.2	9,320	-4.1	8,580
Interstate 39	78.5										
		2.4	2,050	8.4	4,580	4.6	7,190	1.8	8,560	-2.5	8,130
IL251	76.1										
PLA7A 69	56.4	22.2	2,340	5.8	4,120	4.8	6,610	0.9	7,200	-2.3	6,870
IL26	53.9										
		9.7	2,460	4.4	3,780	4.7	6,010	1.6	7,030	-2.3	6,710
US30 West Terminus	44.2										
Subtotal		96.2	343,950	7.3	696,250	3.9	1,024,680	1.4	1,178,140	0.6	1,192,530
East-West Connector		1.4	7,050	6.5	13,180	-0.5	12,500	4.4	19,260	-1.5	18,680
Grand Total		97.6	351,000	7.3	709,430	3.9	1,037,180	1.4	1,197,400	0.6	1,211,210



TABLE 4-D: AVERAGE DAILY VEHICLE MILES TRAVELED BETWEEN INTERCHANGES 1980-2012 (EASTBOUND)

Location	Mile Post	Miles Btwn. Int.	Daily Vehicle Miles				
			1980	1990	2000	2010	2012
Eisenhower Expwy (I-290)	140.4						
		0.4	6,116	11,720	17,796	19,032	19,692
Reagan Memorial Twy (I-88)	140.0						
		1.1	23,925	38,896	58,487	60,093	64,460
Harger (York) Rd.	138.9						
		0.2	4,350	7,072	10,634	10,926	11,720
Reagan Connector	138.7						
PLAZA 51	138.1	0.9	27,351	47,250	63,927	69,237	72,450
Spring Rd.	137.8						
		0.7	21,273	36,750	49,721	53,851	56,350
IL83 (PL54)	137.1						
		0.7	19,551	33,327	44,800	48,657	50,869
Midwest Rd. (PL55)	136.4						
Plaza 52	135.1	2.1	60,354	105,105	147,000	155,295	162,330
Highland Ave. (PL56)	134.3						
		1.1	24,750	50,908	75,471	81,730	85,316
Veterans Mem. Twy (E. Int)	133.2						
		1.9	42,750	97,432	149,492	152,855	154,204
Veterans Mem. Twy (W. Int)	131.3						
		1.3	29,250	68,874	101,270	105,664	107,861
IL53	130.0						
		2.4	39,600	107,304	165,096	179,952	183,648
Naperville Rd.	127.6						
		2.4	32,688	82,920	141,696	168,096	163,152
Winfield Rd. (PL58)	125.2						
		1.9	25,878	65,645	96,596	123,139	118,807
IL59	123.3						
		1.9	16,606	42,959	64,201	97,831	97,565
Fola Rd. (PL60)	120.5						
		2.2	19,228	49,742	74,338	106,986	105,666
Farnsworth Ave. (PL59)	119.2						
PLAZA 61	117.8	2.2	15,774	37,796	55,814	85,558	83,732
IL31 (PL63)	117.0						
		2.6	14,300	35,256	49,842	83,018	80,652
Orchard Rd. (PL64)	114.4						
		1.1	6,050	12,661	17,776	24,046	22,737
IL56	113.3						
		4.0	12,440	26,760	38,880	54,320	49,440
IL47	109.3						
		15.3	54,621	113,220	168,147	230,877	212,211
Peace Rd. (PL65)	94.0						
		0.7	1,834	3,759	6,160	8,589	7,266
DeKalb Oasis	93.3						
		1.9	4,978	10,203	16,720	23,313	19,722
Annie Glidden Rd. (PL67)	91.4						
PLAZA 66	86.2	12.9	26,445	57,276	97,137	120,228	110,682
Interstate 39	78.5						
		2.4	4,920	10,992	17,256	20,544	19,512
IL251	76.1						
PLAZA 69	56.4	22.2	51,948	91,464	146,742	159,840	152,514
IL26	53.9						
		9.7	23,862	36,666	58,297	68,191	65,087
US30 West Terminus	44.2						
Subtotal		96.2	610,842	1,281,957	1,933,296	2,311,868	2,277,645
East-West Connector		1.4	9,870	18,452	17,500	26,964	26,152
Grand Total		97.6	620,712	1,300,409	1,950,796	2,338,832	2,303,797



**TABLE 4-E: GENERAL STATISTICS FOR MAINLINE PLAZAS
(Vehicles/Hour)**

Mainline Plaza	Dir.	30th HV	Period	Mean	Med.	Max.	Min.	Std. Dev.	85th %
51 York Road	WB	7,318	AM Peak	5,671	4,887	7,536	3,026	1,256	7,141
			PM Peak	6,846	6,893	7,365	4,326	334	7,149
			OFF Peak	4,274	4,183	8,290	1,016	1,341	5,926
			Weekend	3,067	3,102	7,392	26	1,803	4,810
			Holidays	2,762	2,741	6,740	185	1,737	4,518
52 Meyers Road	EB	7,884	AM Peak	7,274	7,318	8,264	4,120	528	7,785
			PM Peak	6,239	6,283	7,112	3,844	371	6,562
			OFF Peak	4,001	3,994	7,385	1,360	1,179	5,031
			Weekend	2,904	2,980	7,603	53	1,817	4,612
			Holidays	2,670	2,739	6,879	201	1,699	4,439
61 Aurora	EB	4,820	AM Peak	4,379	4,383	4,953	2,561	355	4,760
			PM Peak	2,342	2,354	3,127	1,423	172	2,494
			OFF Peak	1,898	1,909	3,826	473	660	2,340
			Weekend	1,468	1,477	4,691	115	964	2,375
			Holidays	1,400	1,341	4,229	97	939	2,429
	WB	4,909	AM Peak	1,766	1,636	2,297	973	324	2,146
			PM Peak	4,564	4,610	5,098	3,000	249	4,775
			OFF Peak	1,910	1,813	4,426	504	694	2,684
			Weekend	1,454	1,476	5,056	103	981	2,233
			Holidays	1,362	1,301	4,963	67	997	2,261
66 DeKalb	EB	1,158	AM Peak	379	381	466	247	34	413
			PM Peak	570	563	920	194	83	646
			OFF Peak	406	417	926	83	121	522
			Weekend	394	369	1,585	15	280	698
			Holidays	422	338	1,263	13	340	786
	WB	1,113	AM Peak	447	451	639	298	63	515
			PM Peak	532	526	805	224	71	601
			OFF Peak	418	456	977	103	142	557
			Weekend	400	390	1,287	17	278	705
			Holidays	415	346	1,466	17	337	795

(cont'd)



**TABLE 4-E: GENERAL STATISTICS FOR MAINLINE PLAZAS
(Vehicles/Hour)**

Mainline Plaza	Dir.	30th HV	Period	Mean	Med.	Max.	Min.	Std. Dev.	85th %	
69 Dixon	EB	935	AM Peak	257	255	330	153	28	286	
			PM Peak	431	425	766	112	81	509	
			OFF Peak	322	325	828	53	107	426	
			Weekend	320	285	1,327	18	228	574	
			Holidays	340	284	1,229	19	280	625	
	WB	933	AM Peak	293	290	487	184	54	352	
			PM Peak	405	400	595	174	56	459	
			OFF Peak	335	358	799	93	112	440	
			Weekend	325	307	1,318	11	223	577	
Holidays			338	281	1,234	14	270	612		

AM Peak = Weekday 6:00 AM To 8:00 AM Except Fridays
 PM Peak = Weekday 4:00 PM To 6:00 PM Except Fridays
 OFF Peak = Weekday 5:00 AM To 10:00 PM Except AM and PM Peak Periods
 Weekend = Fridays, Saturdays, and Sundays
 Holidays = See Page 1-4 for a list of Holidays



TABLE 4-F: INDEXED MONTHLY VARIATION BY MAINLINE PLAZA

Month	York Road	Meyers Road	Aurora	DeKalb	Dixon
January	0.91	0.89	0.88	0.85	0.82
February	0.98	0.97	0.95	0.90	0.87
March	1.00	0.99	0.98	0.99	0.97
April	1.01	1.00	1.01	1.00	0.99
May	1.04	1.03	1.04	1.06	1.05
June	1.05	1.06	1.06	1.07	1.08
July	1.01	1.02	1.02	1.05	1.09
August	1.03	1.05	1.06	1.08	1.13
September	0.99	1.00	1.02	1.01	1.03
October	1.02	1.03	1.04	1.02	1.00
November	1.00	1.01	1.01	1.04	1.03
December	0.96	0.96	0.93	0.92	0.93

TABLE 4-G: INDEXED DAILY VARIATION BY MAINLINE PLAZA

Month	Day	York Road	Meyers Road	Aurora	DeKalb	Dixon
August	Monday	1.03	1.05	1.05	1.04	1.08
	Tuesday	1.02	1.04	1.04	1.03	1.07
	Wednesday	1.02	1.04	1.04	1.02	1.08
	Thursday	1.00	1.03	1.03	1.06	1.11
	Friday	1.01	1.04	1.06	1.11	1.15
	Saturday	1.02	1.02	1.05	1.11	1.15
	Sunday	1.04	1.04	1.08	1.15	1.18
December	Monday	0.93	0.94	0.92	0.89	0.88
	Tuesday	0.93	0.93	0.93	0.99	0.98
	Wednesday	0.99	1.00	0.97	1.05	1.06
	Thursday	0.97	0.97	0.94	0.90	0.89
	Friday	1.00	0.99	0.95	0.90	0.93
	Saturday	1.01	1.00	0.96	0.97	1.00
	Sunday	0.96	0.95	0.88	0.80	0.81

Table 4-G includes Monthly Variation



TABLE 4-H: ANNUAL TOTAL TRANSACTIONS BY TOLL PLAZA

Plaza	Plaza Code*	2011	2012	Percentage Change
51 York Road	M1	30,512,890	29,467,497	-3.4%
52 Meyers Road	M1	28,963,071	28,293,142	-2.3%
53 Spring Road	R1	3,092,371	2,978,550	-3.7%
54 Illinois 83	R1	2,898,951	2,866,180	-1.1%
55 Midwest Road	R1	1,311,737	1,261,623	-3.8%
56 Highland Avenue	R	5,778,789	5,523,469	-4.4%
57 Naperville Road	R	3,996,718	3,986,606	-0.3%
58 Winfield Road	R	3,105,454	2,764,640	-11.0%
59 Farnsworth Avenue	R	10,083,931	9,804,609	-2.8%
60 Eola Road	E	3,315,155	3,154,089	-4.9%
61 Aurora	M	28,959,548	27,737,272	-4.2%
63 Illinois 31	R	1,140,224	1,025,736	-10.0%
64 Orchard Road	R	1,602,356	1,399,065	-12.7%
65 Peace Road**	R	3,145,348	3,200,535	1.8%
66 DeKalb	M	7,222,551	6,358,716	-12.0%
67 Annie Glidden Road**	R	2,148,826	1,767,350	-17.8%
69 Dixon	M	5,488,018	5,104,238	-7.0%
Reagan Total		142,765,938	136,693,317	-4.3%

* M=Mainline / R=Ramp / A=Attended Ramp Plaza / E=Electronic Toll Collection Only Ramp
 1=Toll Collected in One Direction Only

** The eastbound entrance ramp from Annie Glidden Road was closed for one month during May and June. Traffic was detoured through the Peace Road plaza.



TABLE 4-I: AVERAGE DAILY TRAFFIC DATA

Year	Average Daily Total			Average Trip
	Vehicles	Vehicle Miles	Transactions	Length (Miles)
1959	8,440	165,204	12,808	19.57
1960	12,276	203,116	16,744	16.55
1961	16,312	257,837	21,563	15.81
1962	17,764	288,501	24,029	16.24
1963	16,569	279,454	23,257	16.87
1964	16,995	264,758	21,574	15.58
1965	17,995	271,692	22,776	15.10
1966	17,947	285,535	25,748	15.91
1967	19,729	311,452	28,672	15.79
1968	22,809	341,062	31,370	14.95
1969	26,158	389,376	36,732	14.89
1970	29,164	429,270	41,225	14.72
1971	31,899	477,703	46,504	14.98
1972	37,858	538,511	52,714	14.22
1973	43,598	599,398	59,488	13.75
1974	41,427	634,698	61,858	15.32
1975	46,937	824,125	74,039	17.56
1976	51,443	907,679	80,957	17.64
1977	52,795	942,618	83,086	17.85
1978	62,128	1,141,523	98,673	18.37
1979	65,025	1,209,224	102,678	18.60
1980	66,901	1,237,492	106,458	18.50
1981	69,977	1,237,492	112,541	17.68
1982	73,089	1,366,570	124,900	18.70
1983	83,292	1,501,330	126,523	18.02
1984	89,716	1,619,407	137,718	18.05
1985	95,566	1,760,944	148,154	18.43
1986	104,972	1,933,134	166,784	18.42
1987	113,033	2,064,188	180,166	18.26
1988	118,956	2,211,706	190,996	18.59
1989	119,346	2,289,542	196,542	19.18
1990	129,849	2,587,888	212,457	19.93
1991	132,723	2,552,325	207,433	19.23
1992	139,437	2,722,109	216,466	19.52
1993	148,050	2,846,936	224,192	19.23
1994	154,551	3,146,111	246,079	20.36
1995	162,260	3,357,807	259,860	20.69
1996	167,010	3,477,775	275,061	20.82
1997	186,370	3,471,458	274,429	18.63
1998	200,930	3,492,638	274,660	17.38
1999	214,190	3,824,597	298,242	17.86
2000	218,150	3,900,147	305,567	17.88
2001	226,930	4,006,550	316,753	17.66
2002	232,780	4,288,781	341,362	18.42
2003	239,380	4,478,762	348,386	18.71
2004	243,640	4,606,017	359,964	18.91
2005	238,580	4,441,784	350,311	18.62
2006	240,500	4,540,450	359,564	18.88
2007	243,310	4,603,873	359,357	18.92
2008	239,410	4,344,648	333,079	18.15
2009	243,680	4,417,393	336,193	18.13
2010	239,680	4,650,235	372,523	19.40
2011	255,540	4,925,591	392,112	19.28
2012	242,590	4,596,370	373,479	18.95



FIGURE 4-B

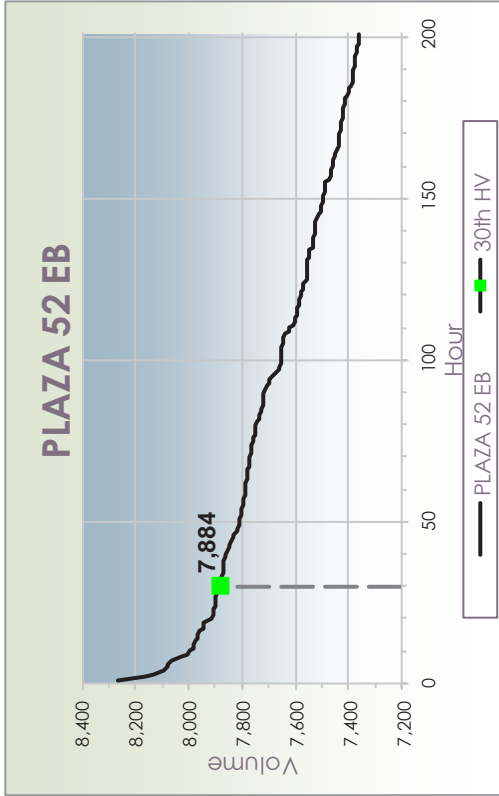

FIGURE 4-D

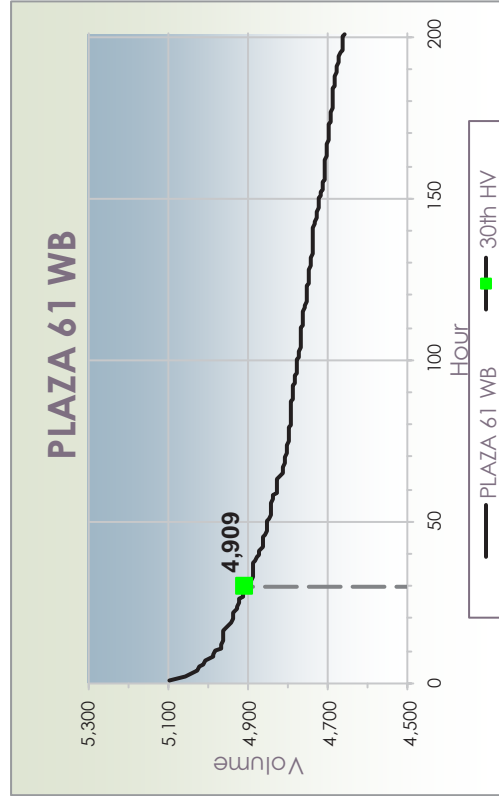
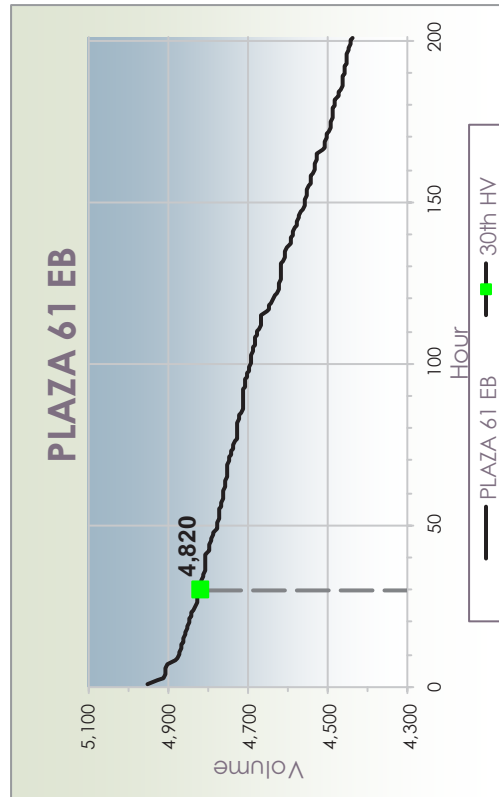

FIGURE 4-A



FIGURE 4-C



MAINLINE PLAZA HIGHEST HOURLY VOLUME



FIGURE 4-F

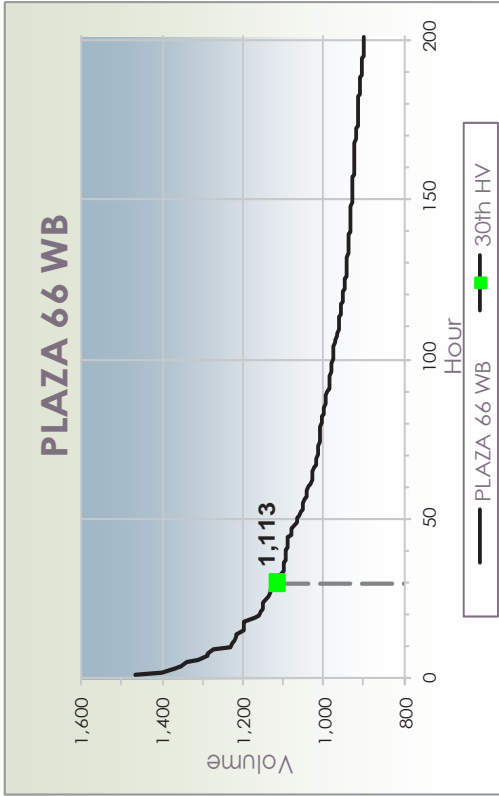

FIGURE 4-E

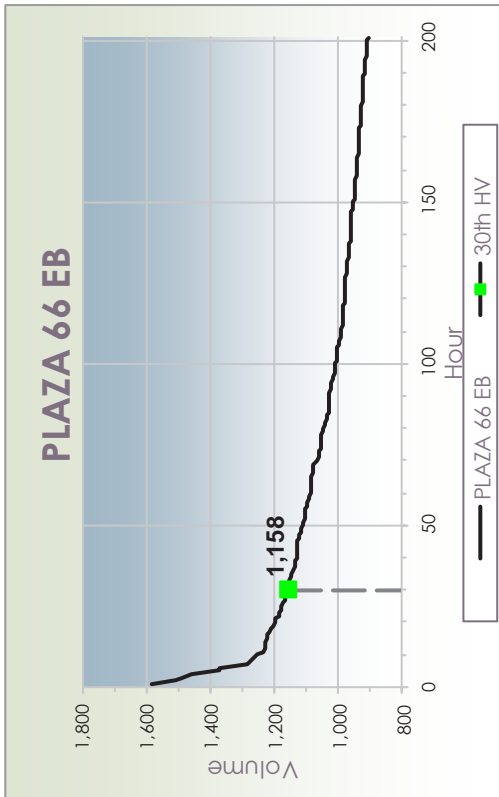

FIGURE 4-H

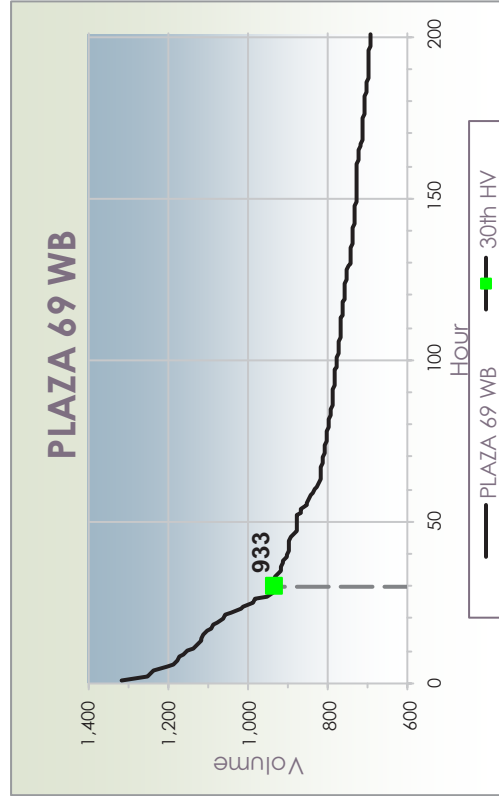
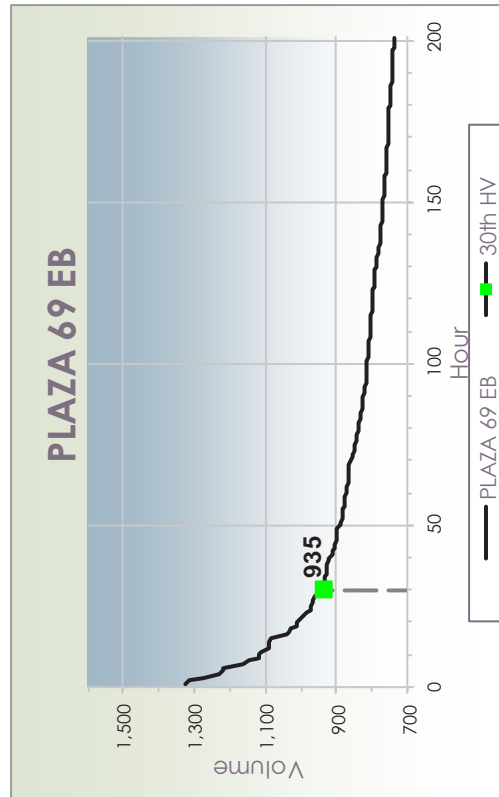

FIGURE 4-G



MAINLINE PLAZA HIGHEST HOURLY VOLUME



FIGURE 4-I

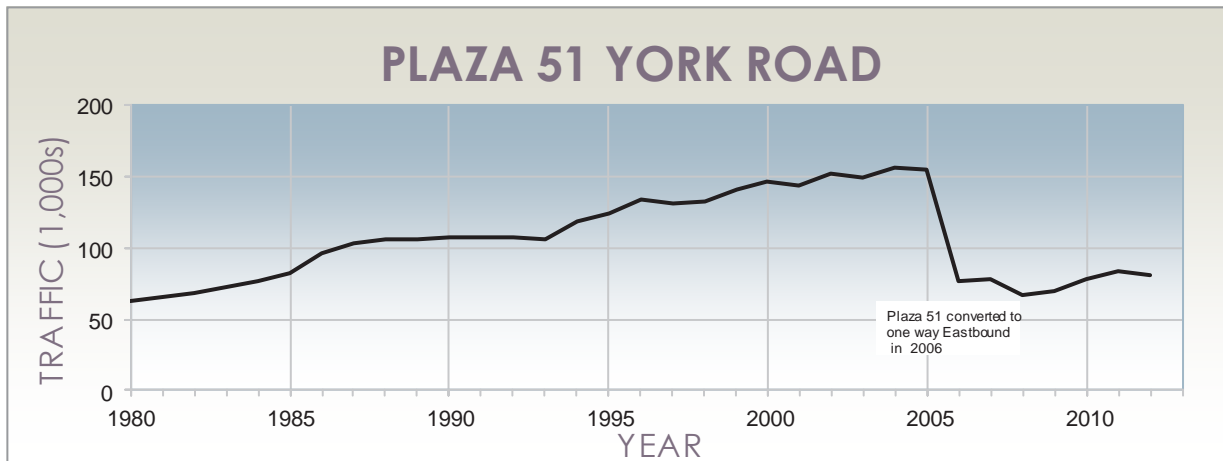

FIGURE 4-J

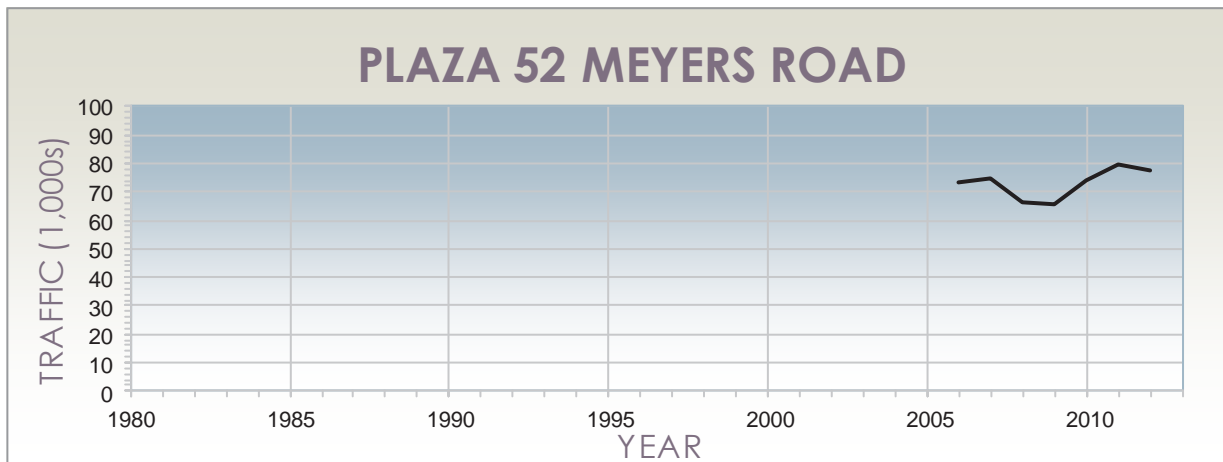
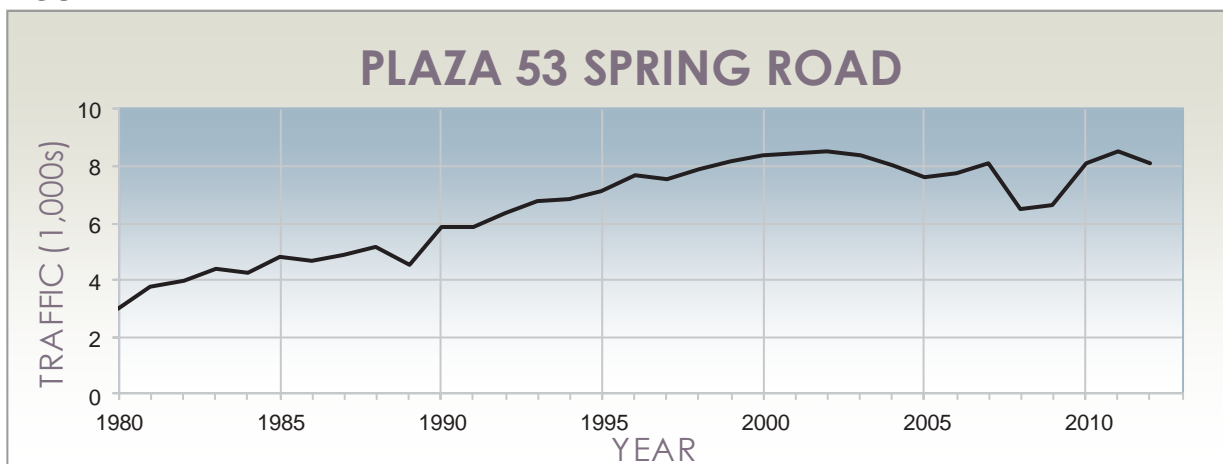

FIGURE 4-K



AVERAGE DAILY TRAFFIC TRENDS



FIGURE 4-L

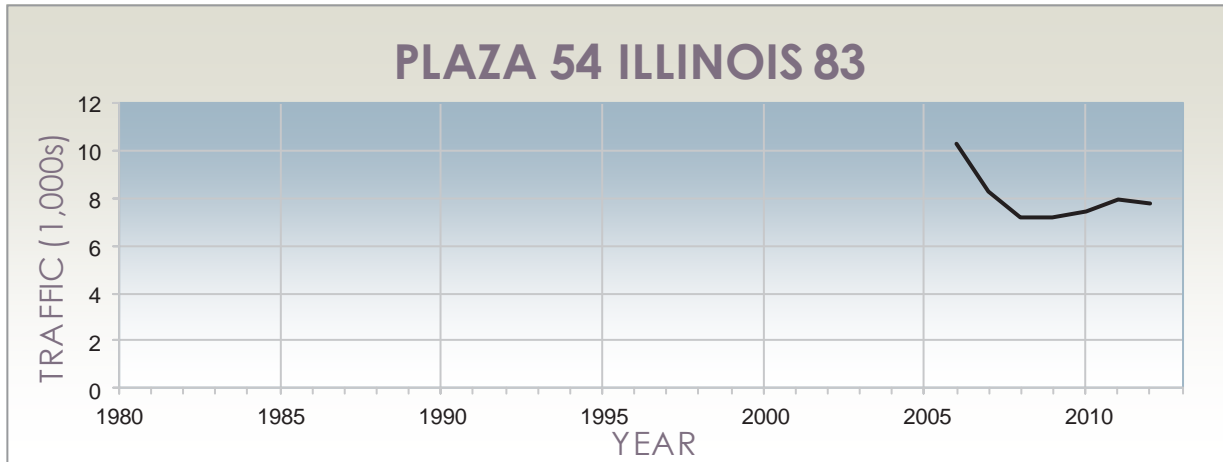

FIGURE 4-M

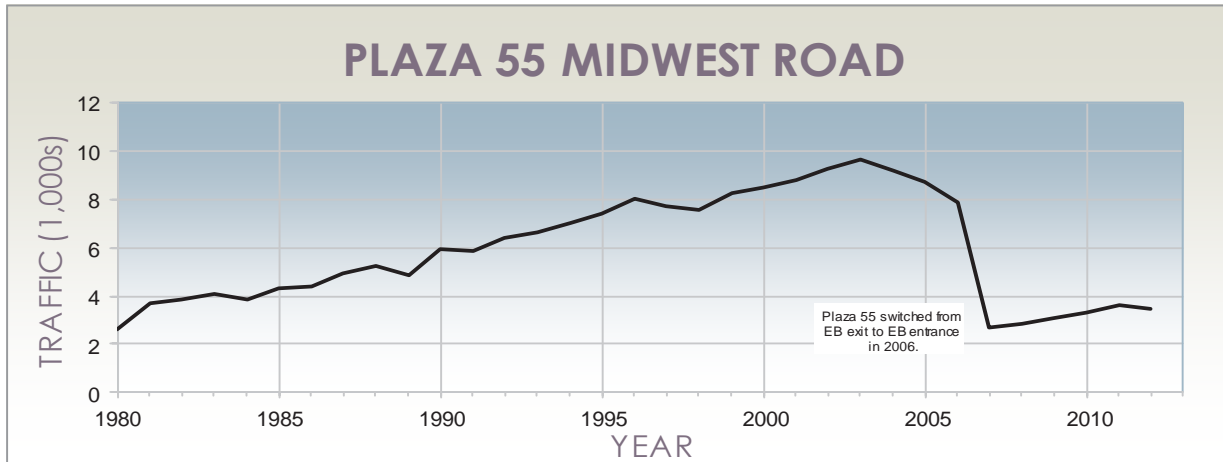
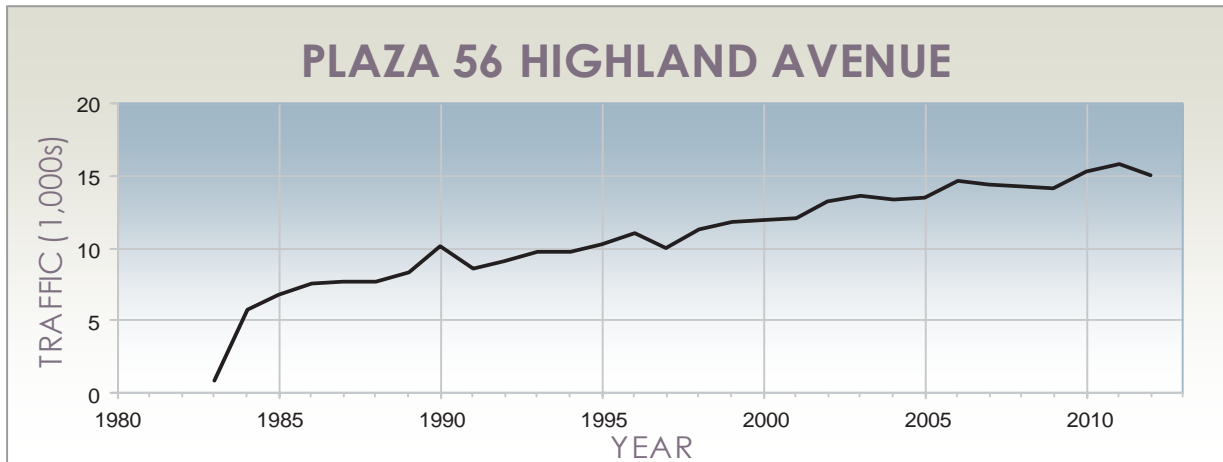

FIGURE 4-N



AVERAGE DAILY TRAFFIC TRENDS



FIGURE 4-O

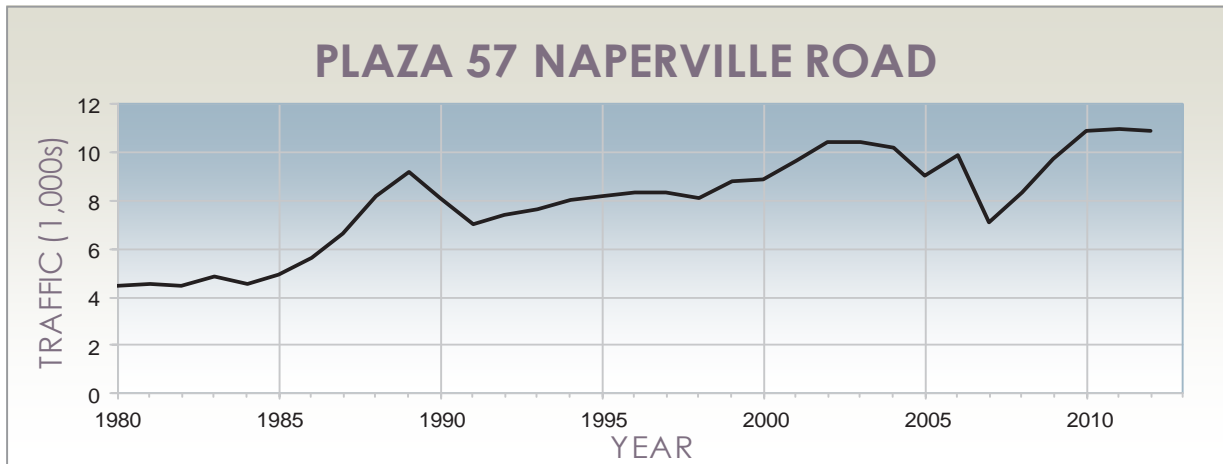

FIGURE 4-P

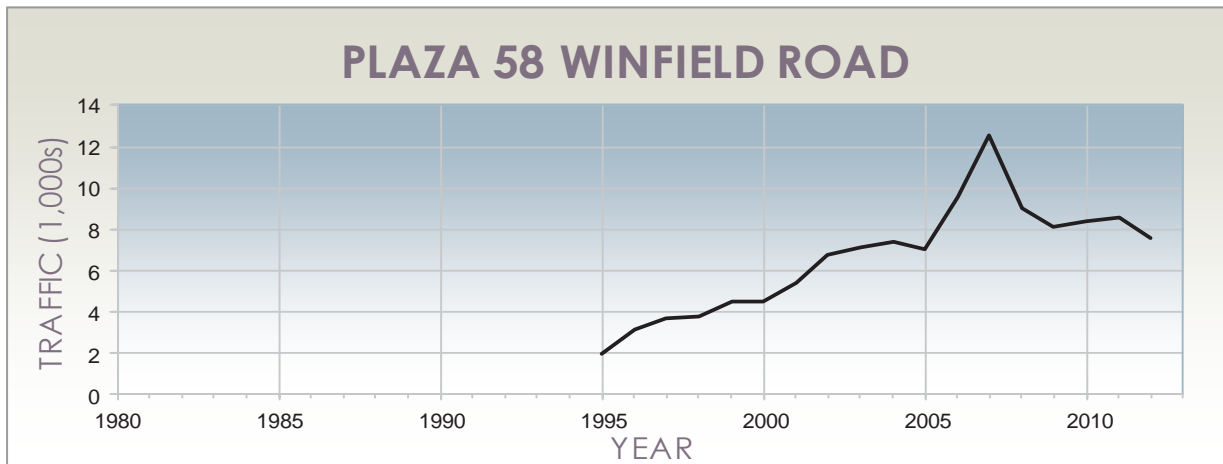
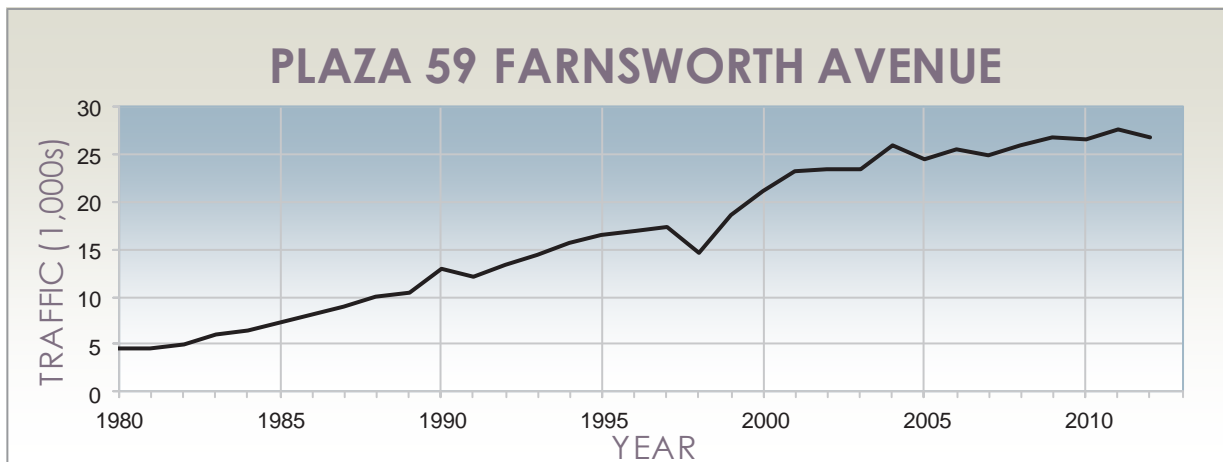

FIGURE 4-Q



AVERAGE DAILY TRAFFIC TRENDS



FIGURE 4-R

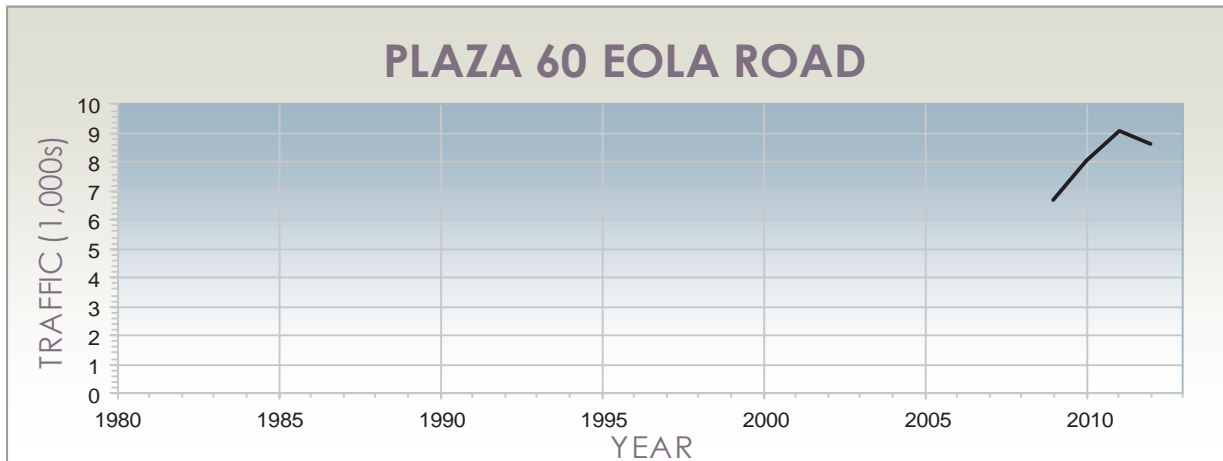

FIGURE 4-S

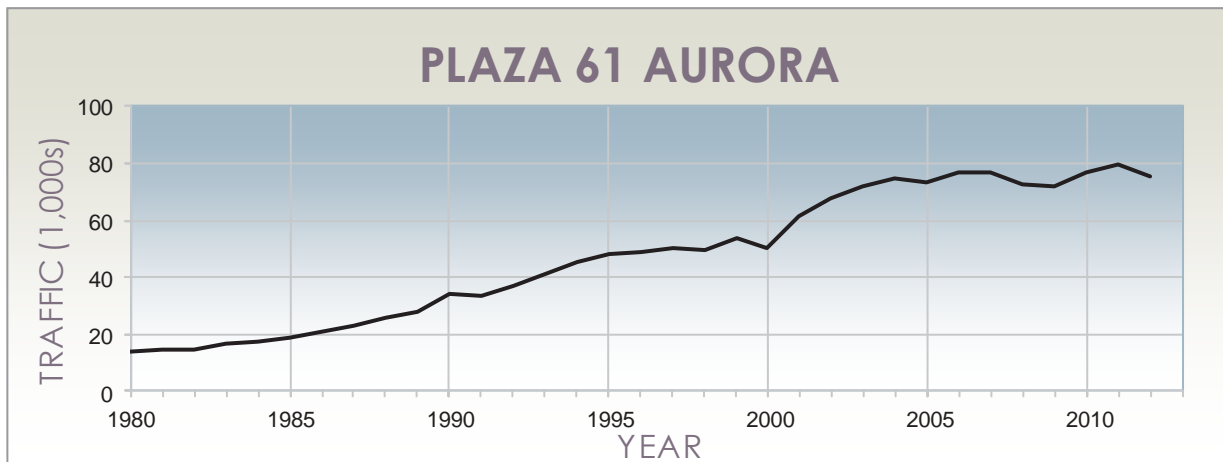
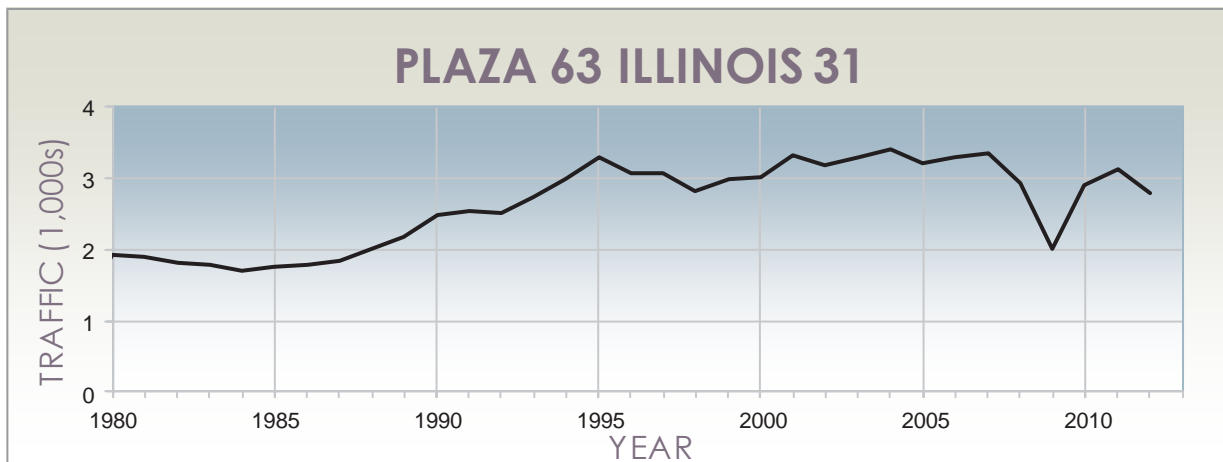

FIGURE 4-T



AVERAGE DAILY TRAFFIC TRENDS



FIGURE 4-U

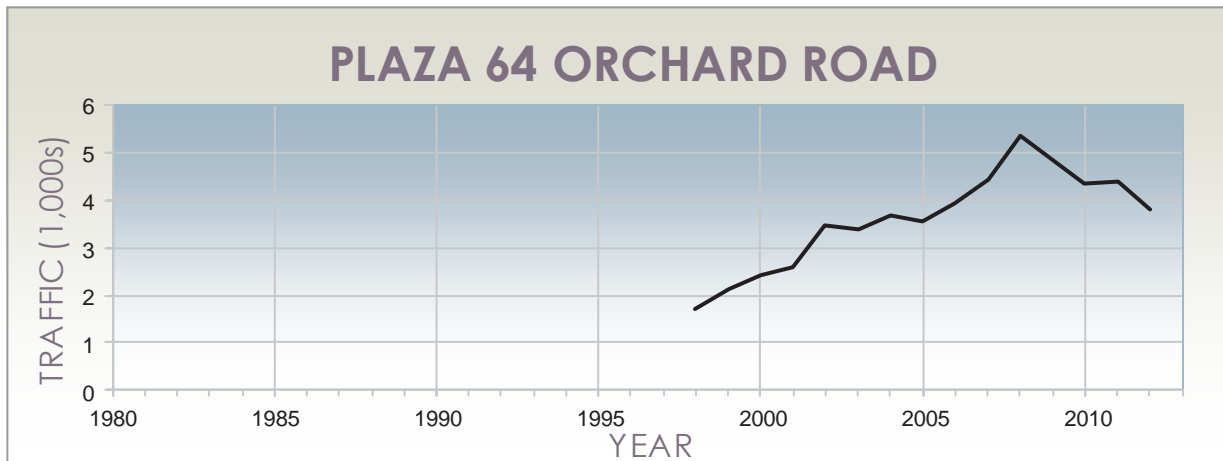

FIGURE 4-V

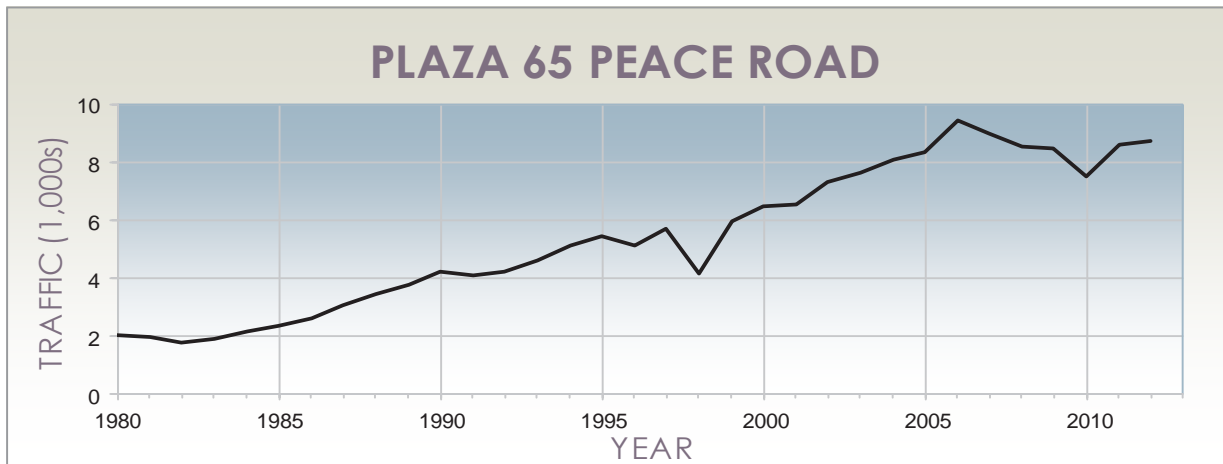
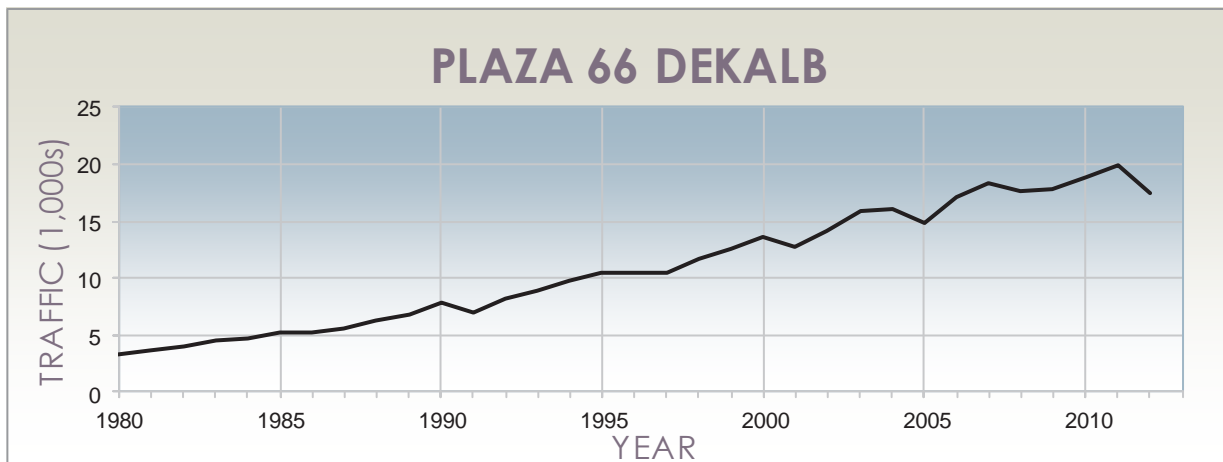

FIGURE 4-W



AVERAGE DAILY TRAFFIC TRENDS



FIGURE 4-X

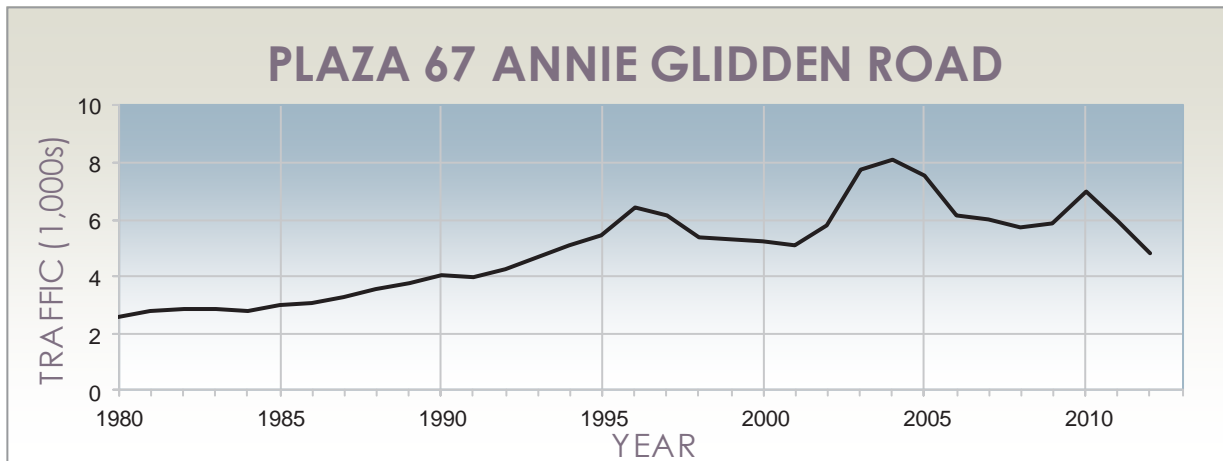

FIGURE 4-Y

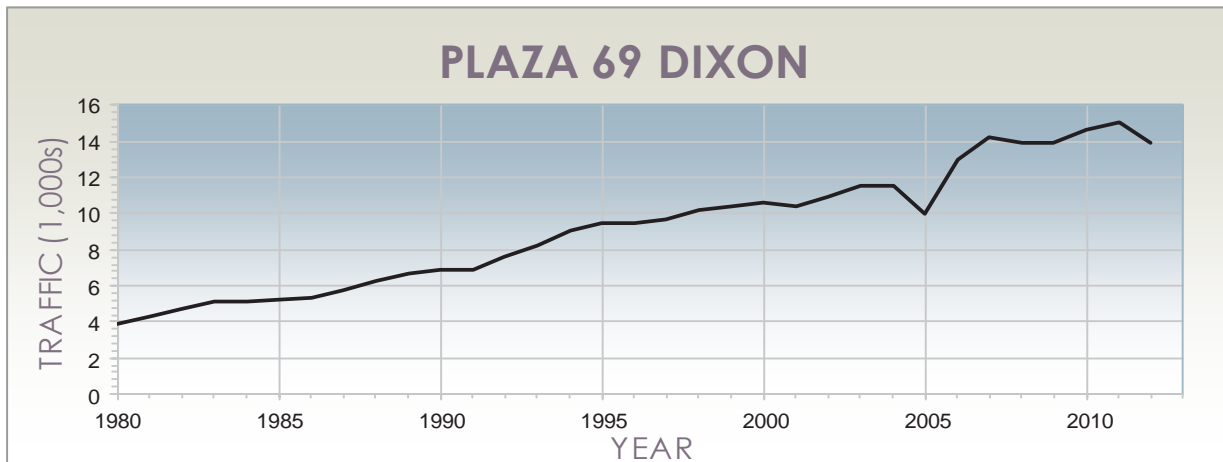
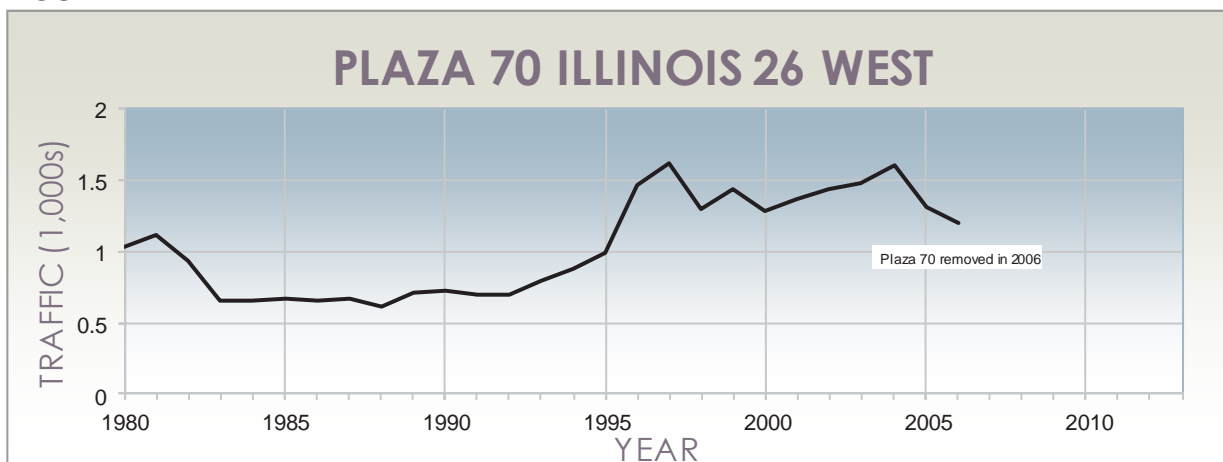

FIGURE 4-Z



AVERAGE DAILY TRAFFIC TRENDS



FIGURE 4-AA

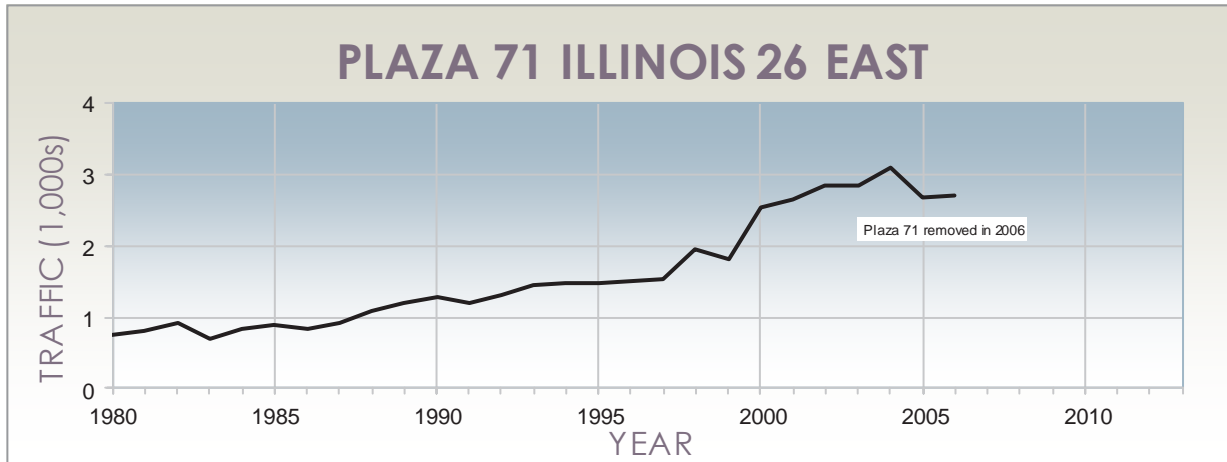

AVERAGE DAILY TRAFFIC TRENDS



This Page Is Intentionally Left Blank

Section 5 Tab





SECTION 5

Veterans Memorial Tollway

TABULATIONS TABLE

	PAGE
5-A Average Daily Traffic Volumes Between interchanges 1980 – 2012 (Northbound)	5-2
5-B Average Daily Vehicle Miles Traveled Between Interchanges 1980 – 2012 (Northbound)	5-3
5-C Average Daily Traffic Volumes Between Interchanges 1980 – 2012 (Southbound)	5-4
5-D Average Daily Vehicle Miles Traveled Between Interchanges 1980 – 2012 (Southbound)	5-5
5-E General Statistics for Mainline Plazas	5-6
5-F Indexed Monthly Variations by Mainline Plaza	5-7
5-G Indexed Daily Variation by Mainline Plaza	5-7
5-H Annual Total Transactions by Toll Plaza	5-8
5-I Average Daily Traffic Data	5-9

ILLUSTRATIONS FIGURE

	PAGE
5-A Mainline Plaza Highest Hourly Volume Plaza 73 NB	5-10
5-B Mainline Plaza Highest Hourly Volume Plaza 73 SB	5-10
5-C Mainline Plaza Highest Hourly Volume Plaza 89 NB	5-10
5-D Mainline Plaza Highest Hourly Volume Plaza 89 SB	5-10
5-E Mainline Plaza Highest Hourly Volume Plaza 99 NB	5-11
5-F Mainline Plaza Highest Hourly Volume Plaza 99 SB	5-11
5-G Average Daily Traffic Trends Plaza 73 Army Trail Road	5-12
5-H Average Daily Traffic Trends Plaza 75 North Avenue	5-12
5-I Average Daily Traffic Trends Plaza 77 Roosevelt Road	5-12
5-J Average Daily Traffic Trends Plaza 79 Butterfield Road	5-13
5-K Average Daily Traffic Trends Plaza 81 Ogden Avenue	5-13
5-L Average Daily Traffic Trends Plaza 83 Maple Avenue	5-13
5-M Average Daily Traffic Trends Plaza 85 63rd Street	5-14
5-N Average Daily Traffic Trends Plaza 87 75th Street	5-14
5-O Average Daily Traffic Trends Plaza 89 Boughton Road	5-14
5-P Average Daily Traffic Trends Plaza 90 Boughton Road Ramp	5-15
5-Q Average Daily Traffic Trends Plaza 93 127th Street	5-15
5-R Average Daily Traffic Trends Plaza 95 Archer Avenue/143rd Street	5-15
5-S Average Daily Traffic Trends Plaza 97 Illinois 7	5-16
5-T Average Daily Traffic Trends Plaza 99 Spring Creek	5-16
5-U Average Daily Traffic Trends Plaza 101 U.S. 6	5-16



TABLE 5-A: AVERAGE DAILY TRAFFIC VOLUMES BETWEEN INTERCHANGES 1980-2012 (NORTHBOUND)

Location	Mile Post	Miles Btwn. Int.	ADT 1980	Average Annual Percent Change	ADT 1990	Average Annual Percent Change	ADT 2000	Average Annual Percent Change	ADT 2010	Average Annual Percent Change	ADT 2012
IL 53 & Army Trail Rd.	29.8										
Plaza 73	29.2	1.9	N/A	-	27,490	6.0	49,080	1.0	54,050	1.0	55,190
North Ave. (PL75)	27.9										
		3.3	N/A	-	31,630	6.0	56,870	0.6	60,470	0.5	61,110
Roosevelt Rd. (PL77)	24.6										
		2.0	N/A	-	29,970	6.5	56,450	0.6	60,120	0.1	60,270
Butterfield Rd. (PL79)	22.6										
		1.1	N/A	-	29,130	6.8	56,210	0.9	61,400	-1.7	59,300
Reagan Mem. Twy (E. Int)	21.5										
		1.4	N/A	-	18,180	2.8	23,900	5.0	38,930	1.5	40,120
Reagan Mem. Twy (W. Int)	20.1										
		0.6	N/A	-	15,330	6.5	28,880	2.1	35,650	1.3	36,610
Ogden Ave. (PL81)	19.5										
		1.2	N/A	-	29,390	6.4	54,880	2.4	69,230	0.4	69,730
Maple Ave. (PL83)	18.3										
		1.1	N/A	-	28,390	6.2	52,010	2.5	66,260	0.5	66,950
63rd St. (PL85)	17.2										
		1.7	N/A	-	25,150	6.2	45,820	2.8	60,440	0.4	60,980
75th St. (PL87)	15.5										
Plaza 89	14.4	1.7	N/A	-	20,320	6.7	38,860	3.8	56,660	0.8	57,560
Boughton Rd. (PL90)	13.8										
		1.5	N/A	-	16,490	7.3	33,470	4.8	53,640	2.0	55,790
I-55	12.3										
		3.4	N/A	-	N/A	-	N/A	-	33,830	0.9	34,440
127th Street (PL93)	8.9										
		1.6	N/A	-	N/A	-	N/A	-	31,670	1.1	32,340
Archer Ave/143rd Street (PL95)	7.3										
		2.5	N/A	-	N/A	-	N/A	-	28,690	1.1	29,350
IL 7-159th Street (PL97)	4.8										
Plaza 99	3.3	4.0	N/A	-	N/A	-	N/A	-	23,480	1.3	24,090
US 6 (PL101)	0.8										
		0.8	N/A	-	N/A	-	N/A	-	18,960	1.7	19,620
I-80	0.0										
Grand Total		29.8	N/A	-	271,470	6.2	496,430	4.3	753,480	0.7	763,450



TABLE 5-B: AVERAGE DAILY VEHICLE MILES TRAVELED BETWEEN INTERCHANGES 1980-2012 (NORTHBOUND)

Location	Mile Post	Miles Btwn. Int.	Daily Vehicle Miles				
			1980	1990	2000	2010	2012
IL 53 & Army Trail Rd.	29.8						
Plaza 73	29.2	1.9	N/A	52,231	93,252	102,695	104,861
North Ave. (PL75)	27.9						
		3.3	N/A	104,379	187,671	199,551	201,663
Roosevelt Rd. (PL77)	24.6						
		2.0	N/A	59,940	112,900	120,240	120,540
Butterfield Rd. (PL79)	22.6						
		1.1	N/A	32,043	61,831	67,540	65,230
Reagan Mem. Twy (E. Int)	21.5						
		1.4	N/A	25,452	33,460	54,502	56,168
Reagan Mem. Twy (W. Int)	20.1						
		0.6	N/A	9,198	17,328	21,390	21,966
Ogden Ave. (PL81)	19.5						
		1.2	N/A	35,268	65,856	83,076	83,676
Maple Ave. (PL83)	18.3						
		1.1	N/A	31,229	57,211	72,886	73,645
63rd St. (PL85)	17.2						
		1.7	N/A	42,755	77,894	102,748	103,666
75th St. (PL87)	15.5						
Plaza 89	14.4	1.7	N/A	34,544	66,062	96,322	97,852
Boughton Rd. (PL90)	13.8						
		1.5	N/A	24,735	50,205	80,460	83,685
I-55	12.3						
		3.4	N/A	N/A	N/A	115,022	117,096
127th Street (PL93)	8.9						
		1.6	N/A	N/A	N/A	50,672	51,744
Archer Ave/143rd Street (PL95)	7.3						
		2.5	N/A	N/A	N/A	71,725	73,375
IL 7-159th Street (PL97)	4.8						
Plaza 99	3.3	4.0	N/A	N/A	N/A	93,920	96,360
US 6 (PL101)	0.8						
		0.8	N/A	N/A	N/A	15,168	15,696
I-80	0.0						
Grand Total		29.8	N/A	451,774	823,670	1,347,917	1,367,223



TABLE 5-C: AVERAGE DAILY TRAFFIC VOLUMES BETWEEN INTERCHANGES 1980-2012 (SOUTHBOUND)

Location	Mile Post	Miles Btwn. Int.	ADT 1980	Average Annual Percent Change	ADT 1990	Average Annual Percent Change	ADT 2000	Average Annual Percent Change	ADT 2010	Average Annual Percent Change	ADT 2012
IL 53 & Army Trail Rd.	29.8										
Plaza 73	29.2	1.9	N/A	-	27,380	6.2	49,870	0.8	54,110	1.3	55,500
North Ave. (PL75)	27.9										
		3.3	N/A	-	31,280	6.4	58,060	0.4	60,560	0.3	60,900
Roosevelt Rd. (PL77)	24.6										
		2.0	N/A	-	29,340	6.9	56,940	0.8	61,360	-0.3	60,970
Butterfield Rd. (PL79)	22.6										
		1.1	N/A	-	28,420	7.1	56,520	0.9	61,900	-2.5	58,890
Reagan Mem. Twy (E. Int)	21.5										
		1.4	N/A	-	24,240	7.1	48,220	1.3	55,070	0.9	56,100
Reagan Mem. Twy (W. Int)	20.1										
		0.6	N/A	-	26,770	6.8	51,540	2.0	62,870	1.3	64,540
Ogden Ave. (PL81)	19.5										
		1.2	N/A	-	29,410	6.6	55,680	2.2	69,140	0.6	70,040
Maple Ave. (PL83)	18.3										
		1.1	N/A	-	28,600	6.3	52,680	2.4	66,600	0.4	67,130
63rd St. (PL85)	17.2										
		1.7	N/A	-	25,390	6.3	46,870	2.6	60,820	0.1	60,980
75th St. (PL87)	15.5										
Plaza 89	14.4	1.7	N/A	-	20,530	6.8	39,640	3.8	57,420	0.3	57,740
Boughton Rd. (PL90)	13.8										
		1.5	N/A	-	16,740	7.3	33,900	5.1	55,790	2.0	58,030
I-55	12.3										
		3.4	N/A	-	N/A	-	N/A	-	33,800	-0.9	33,200
127th Street (PL93)	8.9										
		1.6	N/A	-	N/A	-	N/A	-	31,350	-0.5	31,010
Archer Ave/143rd Street (PL95)	7.3										
		2.5	N/A	-	N/A	-	N/A	-	28,660	-0.4	28,450
IL 7-159th Street (PL97)	4.8										
Plaza 99	3.3	4.0	N/A	-	N/A	-	N/A	-	23,530	0.0	23,550
US 6 (PL101)	0.8										
		0.8	N/A	-	N/A	-	N/A	-	18,410	3.1	19,560
I-80	0.0										
Grand Total		29.8	N/A	-	288,100	6.7	549,920	3.8	801,390	0.3	806,590



TABLE 5-D: AVERAGE DAILY VEHICLE MILES TRAVELED BETWEEN INTERCHANGES 1980-2012 (SOUTHBOUND)

Location	Mile Post	Miles Btwn. Int.	Daily Vehicle Miles				
			1980	1990	2000	2010	2012
IL 53 & Army Trail Rd.	29.8						
Plaza 73	29.2	1.9	N/A	52,022	94,753	102,809	105,450
North Ave. (PL75)	27.9						
		3.3	N/A	103,224	191,598	199,848	200,970
Roosevelt Rd. (PL77)	24.6						
		2.0	N/A	58,680	113,880	122,720	121,940
Butterfield Rd. (PL79)	22.6						
		1.1	N/A	31,262	62,172	68,090	64,779
Reagan Mem. Twy (E. Int)	21.5						
		1.4	N/A	33,936	67,508	77,098	78,540
Reagan Mem. Twy (W. Int)	20.1						
		0.6	N/A	16,062	30,924	37,722	38,724
Ogden Ave. (PL81)	19.5						
		1.2	N/A	35,292	66,816	82,968	84,048
Maple Ave. (PL83)	18.3						
		1.1	N/A	31,460	57,948	73,260	73,843
63rd St. (PL85)	17.2						
		1.7	N/A	43,163	79,679	103,394	103,666
75th St. (PL87)	15.5						
Plaza 89	14.4	1.7	N/A	34,901	67,388	97,614	98,158
Boughton Rd. (PL90)	13.8						
		1.5	N/A	25,110	50,850	83,685	87,045
I-55	12.3						
		3.4	N/A	N/A	N/A	114,920	112,880
127th Street (PL93)	8.9						
		1.6	N/A	N/A	N/A	50,160	49,616
Archer Ave/143rd Street (PL95)	7.3						
		2.5	N/A	N/A	N/A	71,650	71,125
IL 7-159th Street (PL97)	4.8						
Plaza 99	3.3	4.0	N/A	N/A	N/A	94,120	94,200
US 6 (PL101)	0.8						
		0.8	N/A	N/A	N/A	14,728	15,648
I-80	0.0						
Grand Total		29.8	N/A	465,112	883,516	1,394,786	1,400,632



**TABLE 5-E: GENERAL STATISTICS FOR MAINLINE PLAZAS
(Vehicles/Hour)**

Mainline Plaza	Dir.	30th HV	Period	Mean	Med.	Max.	Min.	Std. Dev.	85th %
73 Army Trail Road	NB	6,235	AM Peak	5,340	5,074	6,483	2,737	729	6,163
			PM Peak	4,820	4,874	5,581	2,686	387	5,194
			OFF Peak	2,894	2,873	5,712	945	964	3,732
			Weekend	2,016	1,979	6,195	122	1,351	3,323
			Holidays	1,855	1,847	5,907	95	1,304	3,199
	SB	6,241	AM Peak	4,241	3,636	5,824	2,108	1,010	5,360
			PM Peak	5,775	5,825	6,432	3,703	390	6,129
			OFF Peak	2,964	2,822	5,932	898	1,100	4,435
			Weekend	2,017	1,968	6,519	131	1,392	3,245
			Holidays	1,866	1,808	5,981	87	1,358	3,145
89 Boughton Road	NB	6,820	AM Peak	6,183	6,286	6,982	3,707	528	6,707
			PM Peak	4,045	4,064	4,726	2,496	326	4,377
			OFF Peak	2,927	2,976	5,701	838	953	3,690
			Weekend	2,185	2,251	6,961	146	1,419	3,529
			Holidays	2,040	2,101	6,511	122	1,371	3,491
	SB	6,912	AM Peak	3,123	3,005	3,984	1,739	479	3,679
			PM Peak	6,527	6,610	7,132	4,091	353	6,822
			OFF Peak	3,035	2,844	6,627	1,010	1,106	4,210
			Weekend	2,175	2,150	7,188	139	1,475	3,449
			Holidays	2,042	1,912	6,773	104	1,493	3,457
99 Spring Creek	NB	3,013	AM Peak	2,496	2,472	3,336	1,380	345	2,860
			PM Peak	1,777	1,806	2,220	1,038	187	1,959
			OFF Peak	1,193	1,214	2,259	329	379	1,537
			Weekend	935	968	2,972	63	607	1,548
			Holidays	899	915	2,727	39	612	1,561
	SB	2,773	AM Peak	1,514	1,474	2,012	810	258	1,810
			PM Peak	2,371	2,417	2,946	1,495	204	2,570
			OFF Peak	1,206	1,187	2,493	353	418	1,648
			Weekend	914	912	3,248	47	619	1,494
			Holidays	883	804	3,039	47	652	1,540

AM Peak = Weekday 6:00 AM To 8:00 AM Except Fridays
 PM Peak = Weekday 4:00 PM To 6:00 PM Except Fridays
 OFF Peak = Weekday 5:00 AM To 10:00 PM Except AM and PM Peak Periods
 Weekend = Fridays, Saturdays, and Sundays
 Holidays = See Page 1-4 for list of Holidays



TABLE 5-F: INDEXED MONTHLY VARIATION BY MAINLINE PLAZA

Month	Army Trail Road	Boughton Road	Spring Creek
January	0.88	0.86	0.81
February	0.94	0.92	0.87
March	0.96	0.95	0.92
April	0.99	0.97	0.95
May	1.04	1.04	1.03
June	1.08	1.08	1.10
July	1.04	1.05	1.08
August	1.08	1.08	1.11
September	1.03	1.04	1.07
October	1.04	1.06	1.08
November	1.00	1.01	1.04
December	0.92	0.94	0.94

TABLE 5-G: INDEXED DAILY VARIATION BY MAINLINE PLAZA

Month	Day	Army Trail Road	Boughton Road	Spring Creek
August	Monday	1.08	1.08	1.11
	Tuesday	1.05	1.06	1.09
	Wednesday	1.06	1.07	1.11
	Thursday	1.05	1.06	1.09
	Friday	1.06	1.07	1.11
	Saturday	1.06	1.06	1.10
	Sunday	1.08	1.07	1.11
December	Monday	0.92	0.93	0.95
	Tuesday	0.92	0.93	0.97
	Wednesday	0.96	0.98	0.99
	Thursday	0.94	0.96	0.97
	Friday	0.95	0.97	0.96
	Saturday	0.95	0.96	0.94
	Sunday	0.90	0.90	0.87

Table 5-G includes Monthly Variation



TABLE 5-H: ANNUAL TOTAL TRANSACTIONS BY TOLL PLAZA

Plaza	Plaza Code*	2011	2012	Percentage Change
73 Army Trail Road	M	41,491,667	40,510,323	-2.4%
75 North Avenue	R	10,194,244	9,927,006	-2.6%
77 Roosevelt Road	R	5,752,927	5,526,088	-3.9%
79 Butterfield Road	R	6,674,423	6,173,786	-7.5%
81 Ogden Avenue	R	1,688,446	1,602,316	-5.1%
83 Maple Avenue	R	4,921,713	4,497,912	-8.6%
85 63rd Street	R	6,502,278	6,239,074	-4.0%
87 75th Street	R	6,713,145	5,922,946	-11.8%
89 Boughton Mainline	M	43,096,264	42,194,504	-2.1%
90 Boughton Road	R	4,896,359	4,518,836	-7.7%
93 127th Street	R	2,519,969	2,295,140	-8.9%
95 Archer Avenue/143rd Street	R	3,127,686	2,889,614	-7.6%
97 Illinois 7	R	5,132,620	4,723,496	-8.0%
99 Spring Creek	M	17,189,789	17,427,932	1.4%
101 U.S. 6	R	1,208,552	1,345,929	11.4%
Veterans Memorial Total		161,110,082	155,794,902	-3.3%

* M=Mainline / R=Ramp / A=Attended Ramp Plaza / E=Electronic Toll Collection Only Ramp
1=Toll Collected in One Direction Only



TABLE 5-I: AVERAGE DAILY TRAFFIC DATA

Year	Average Daily Total			Average Trip
	Vehicles	Vehicle Miles	Transactions	Length (Miles)
1989	1,718	18,733	2,794	10.90
1990	116,106	913,325	148,394	7.87
1991	112,664	1,080,313	177,384	9.59
1992	125,446	1,203,491	198,723	9.59
1993	133,101	1,280,823	211,525	9.62
1994	135,381	1,297,315	214,764	9.58
1995	136,250	1,324,254	219,397	9.72
1996	140,780	1,397,726	230,871	9.93
1997	149,430	1,481,389	240,479	9.91
1998	153,670	1,524,455	253,551	9.92
1999	162,950	1,578,153	267,579	9.68
2000	174,040	1,712,671	281,509	9.84
2001	184,280	1,820,705	297,086	9.88
2002	192,155	1,916,090	313,813	9.97
2003	193,150	1,940,636	316,557	10.05
2004	202,630	2,006,635	329,275	9.90
2005	199,310	1,953,866	321,209	9.80
2006	205,210	1,972,819	327,759	9.61
2007	212,000	2,007,320	335,879	9.47
2008	248,120	2,705,470	418,865	10.90
2009	251,180	2,783,566	428,534	11.08
2010	246,290	2,740,256	425,576	11.13
2011	253,630	2,845,902	442,475	11.22
2012	245,530	2,767,855	425,669	11.27



FIGURE 5-B



FIGURE 5-D

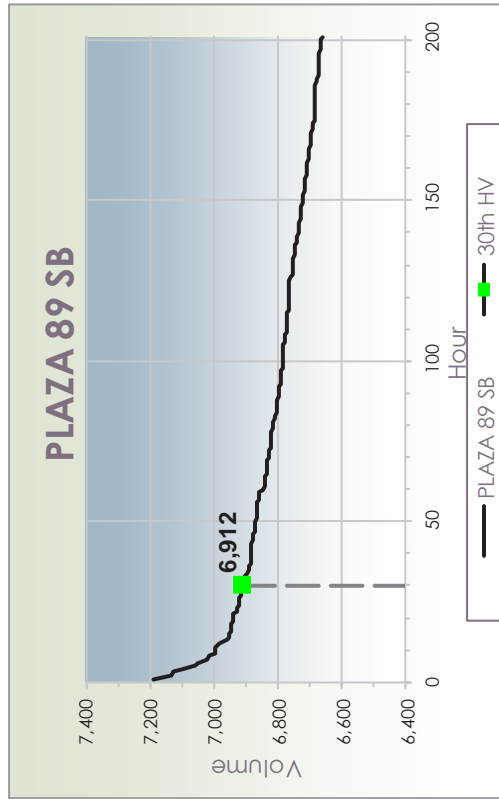

FIGURE 5-A

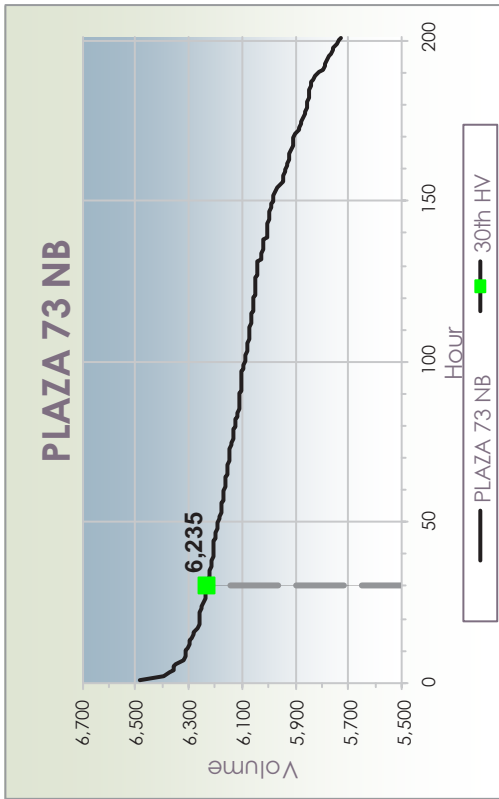
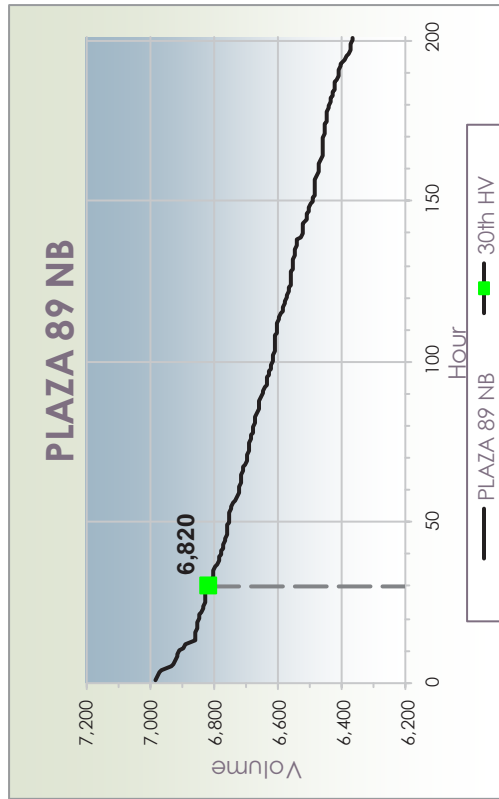

FIGURE 5-C



MAINLINE PLAZA HIGHEST HOURLY VOLUME



FIGURE 5-F



FIGURE 5-E

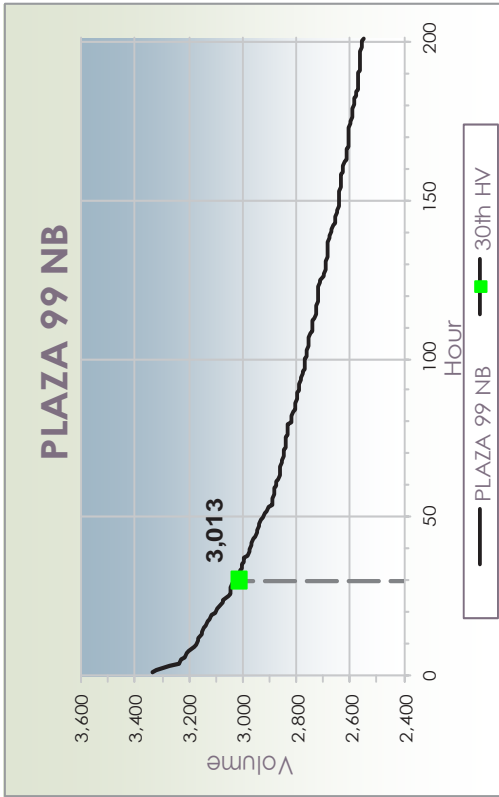

MAINLINE PLAZA HIGHEST HOURLY VOLUME



FIGURE 5-G

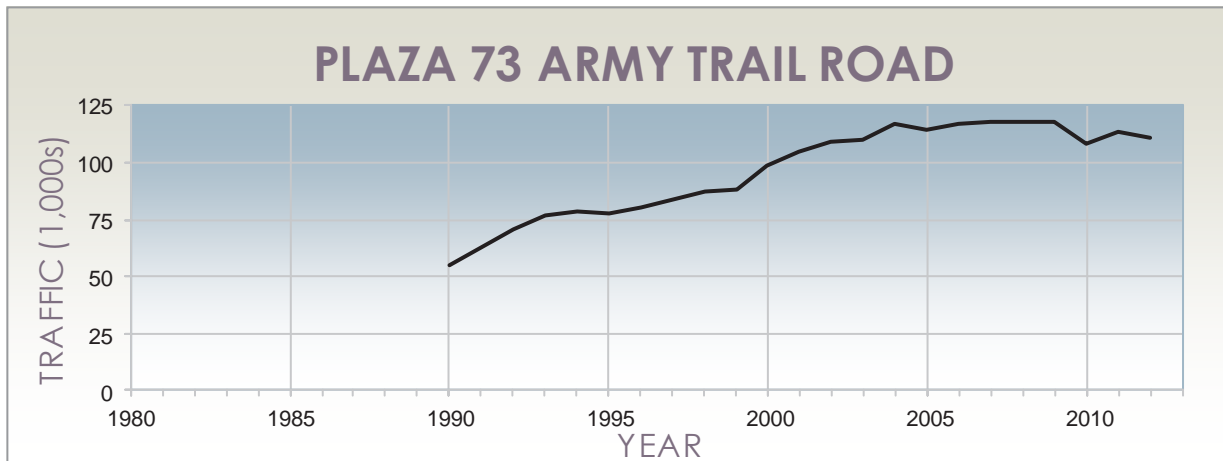

FIGURE 5-H

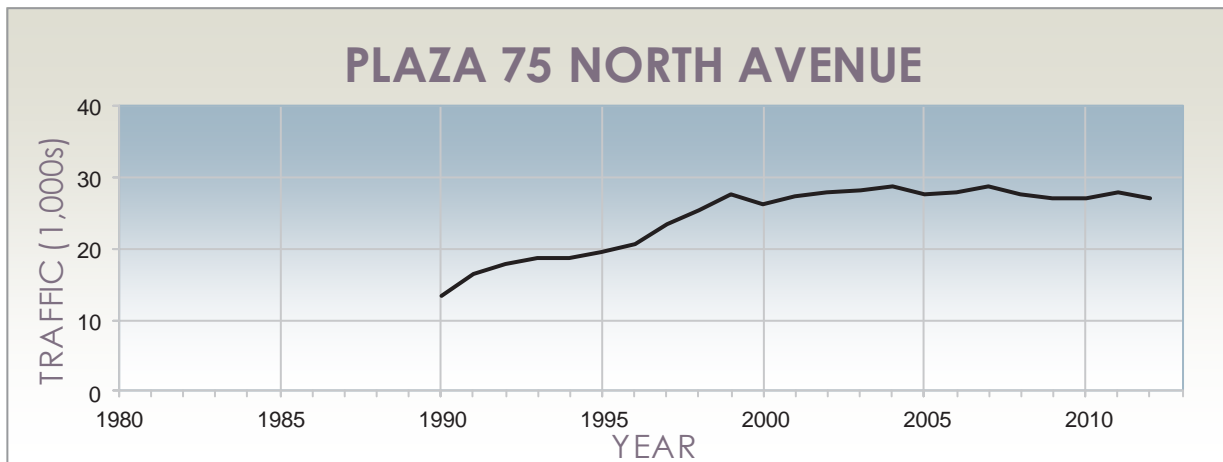
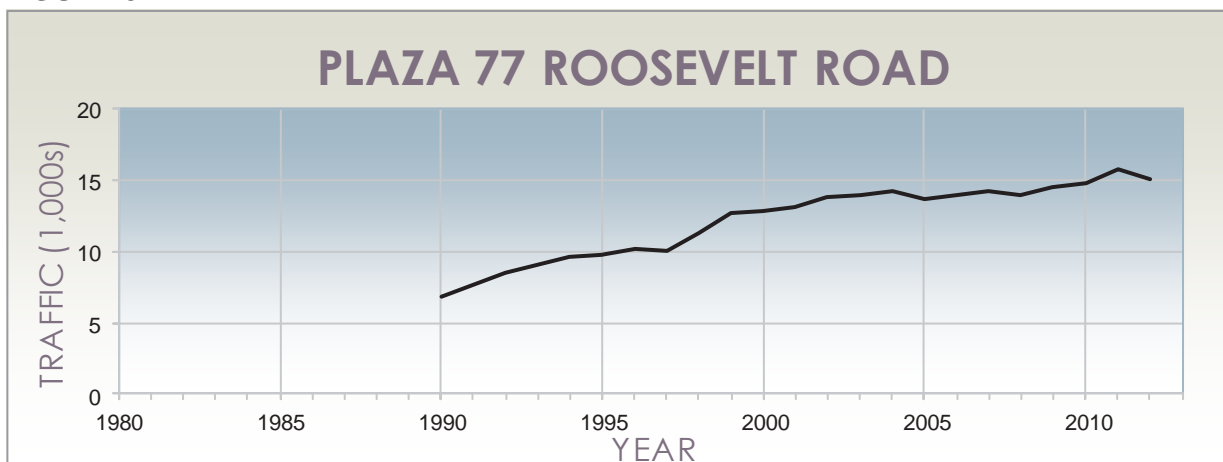

FIGURE 5-I



AVERAGE DAILY TRAFFIC TRENDS



FIGURE 5-J

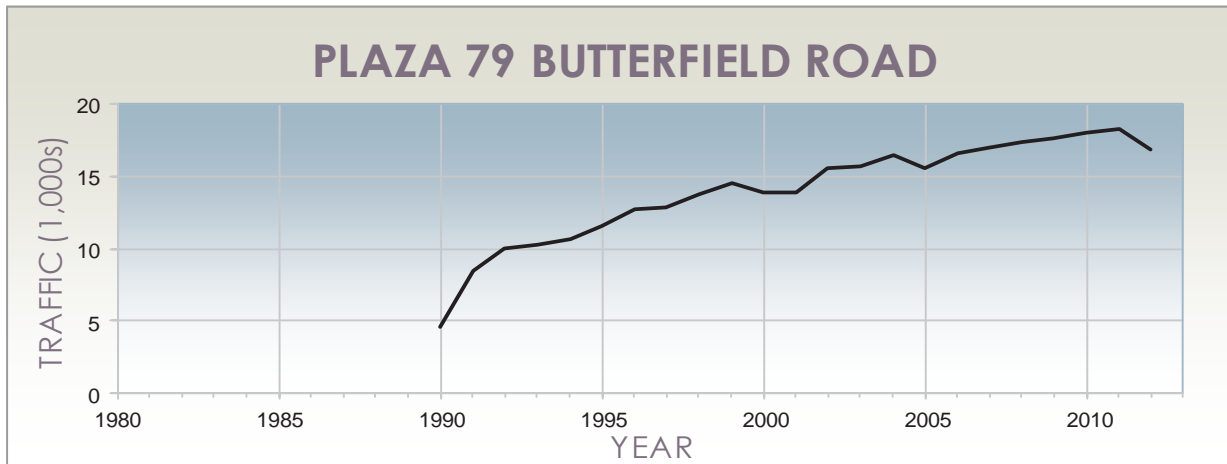

FIGURE 5-K

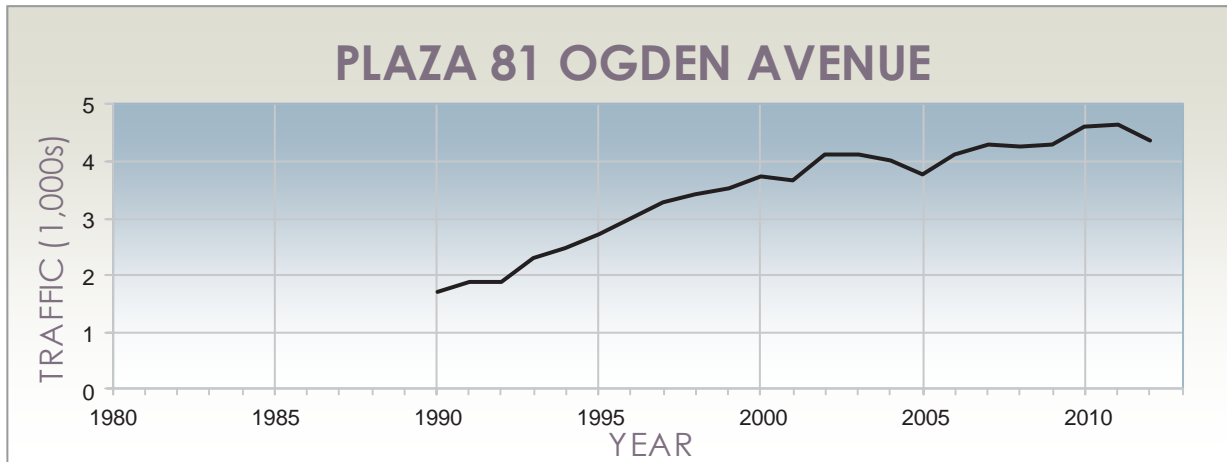
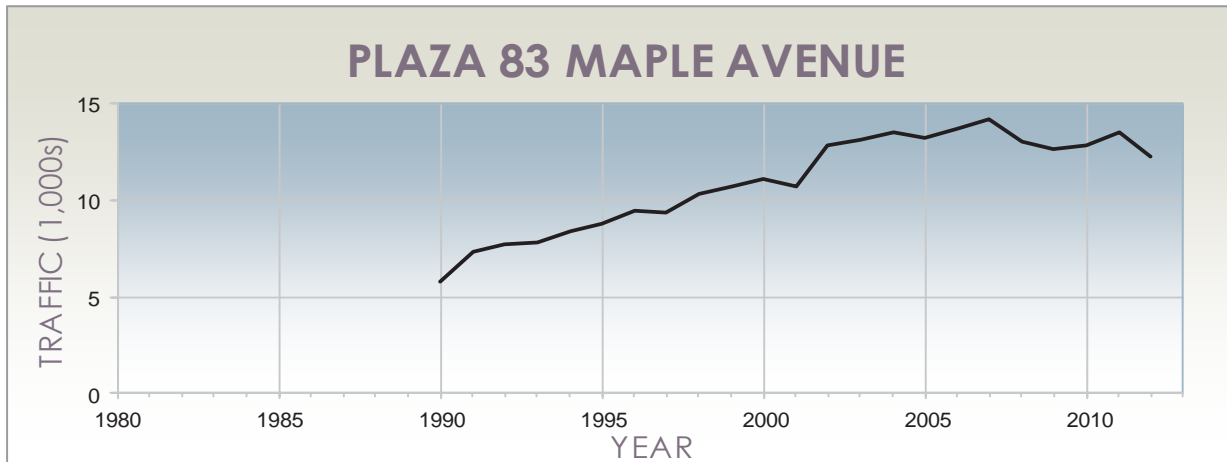

FIGURE 5-L



AVERAGE DAILY TRAFFIC TRENDS



FIGURE 5-M

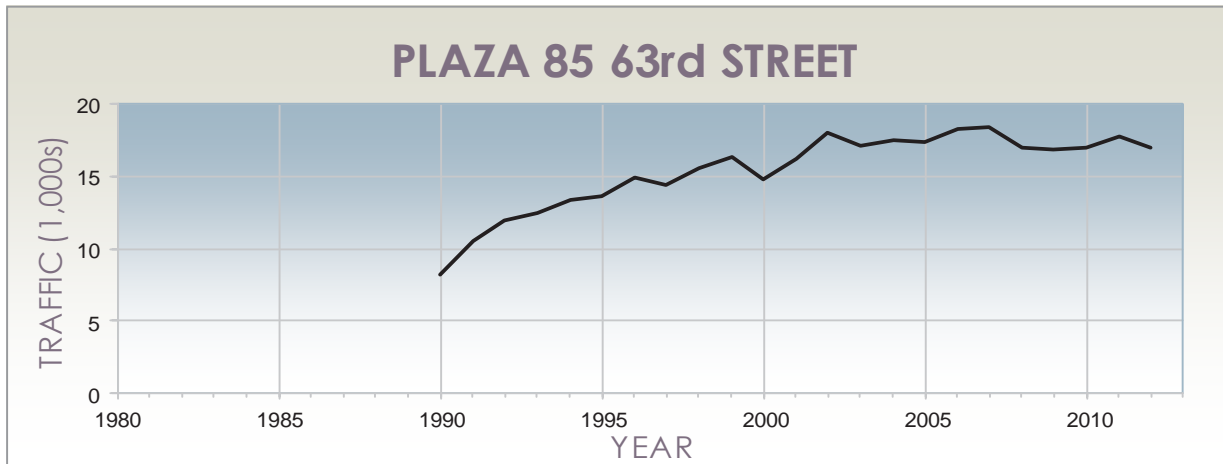

FIGURE 5-N

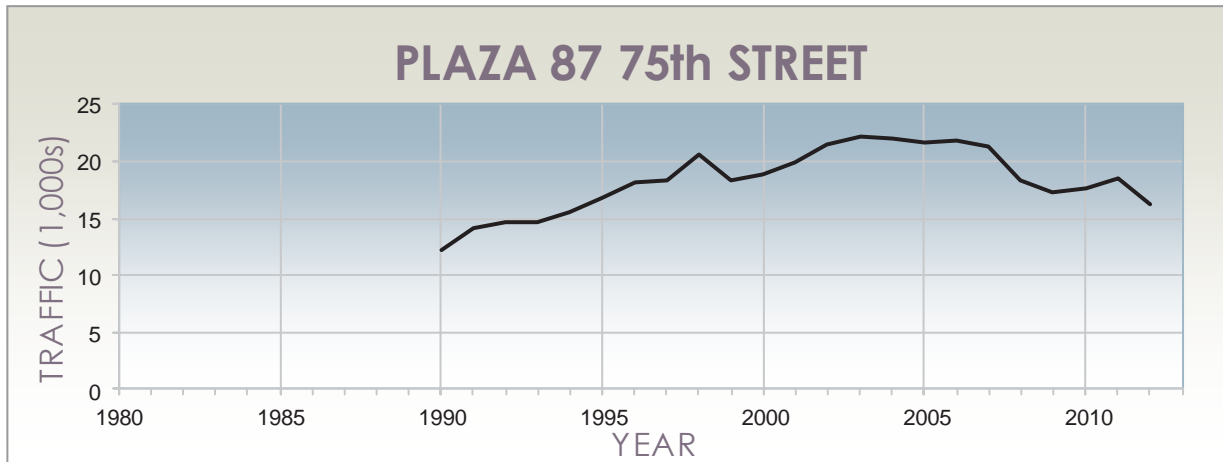
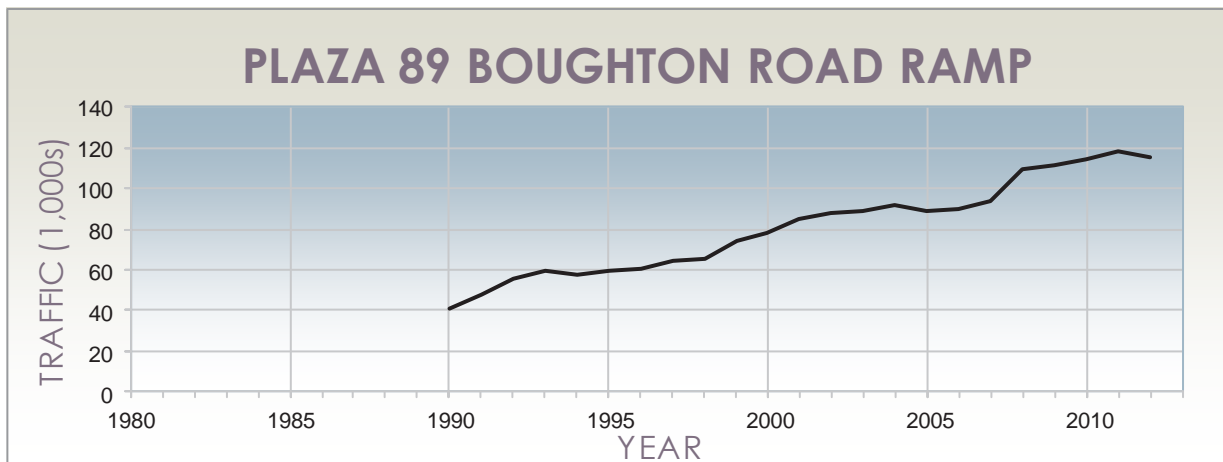

FIGURE 5-O



AVERAGE DAILY TRAFFIC TRENDS



FIGURE 5-P

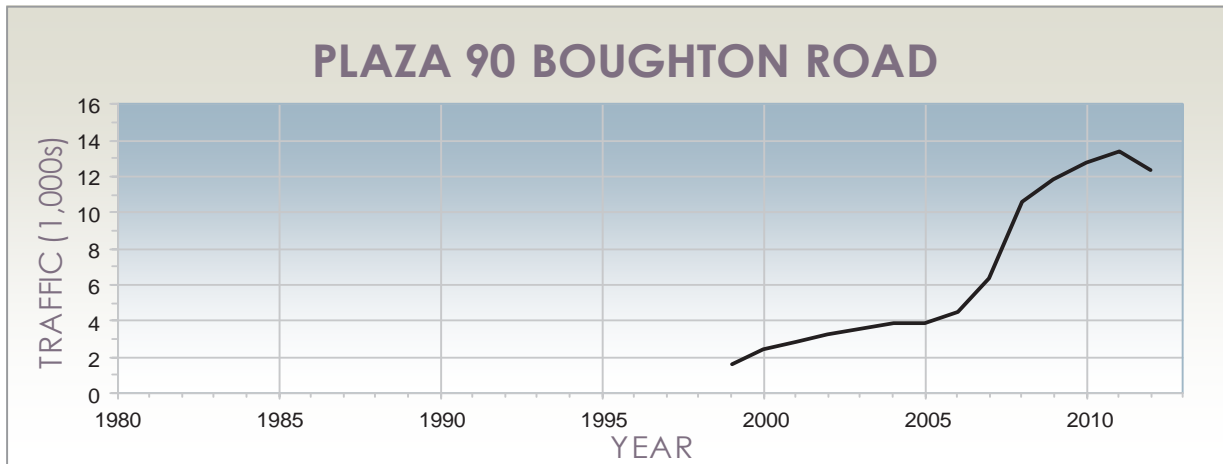

FIGURE 5-Q

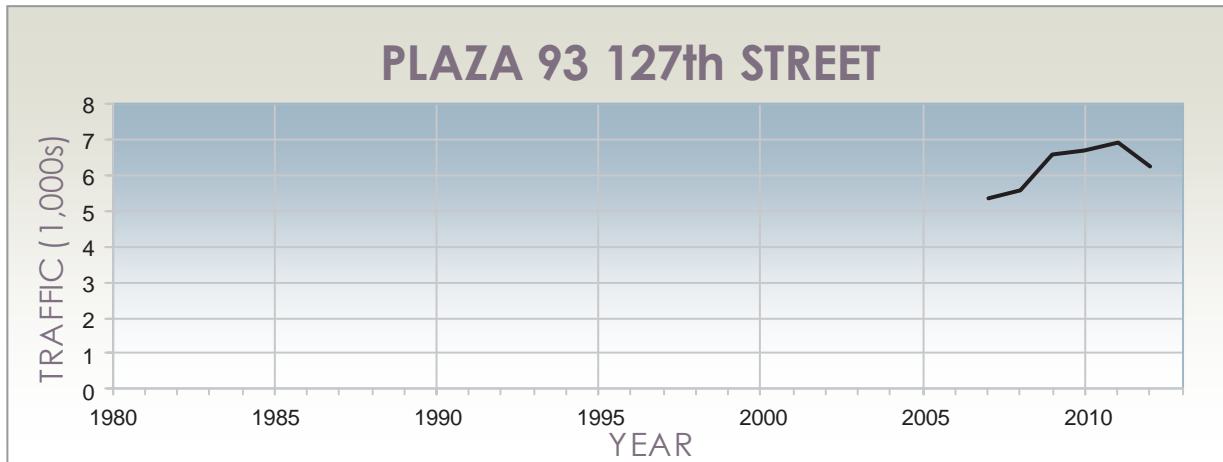
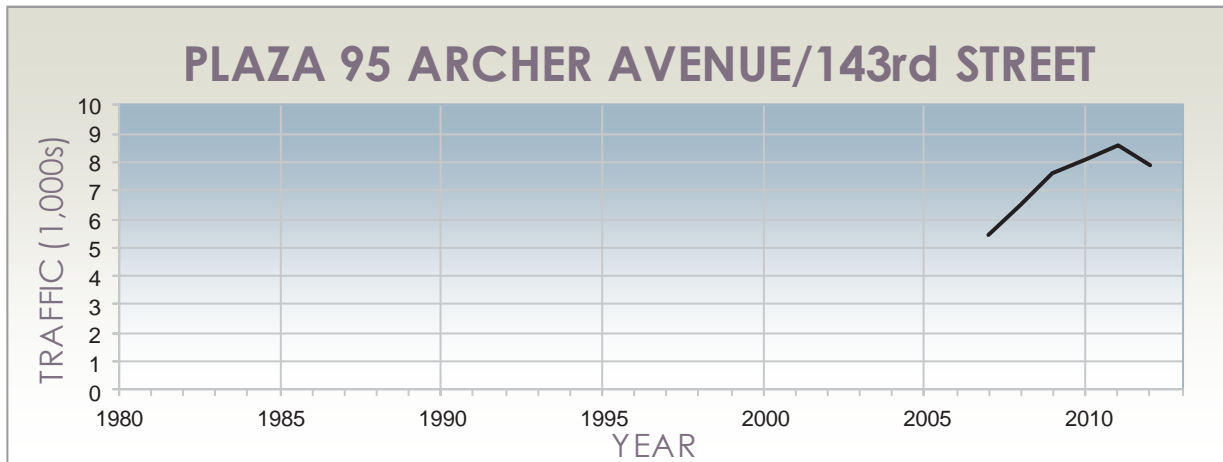

FIGURE 5-R



AVERAGE DAILY TRAFFIC TRENDS



FIGURE 5-S

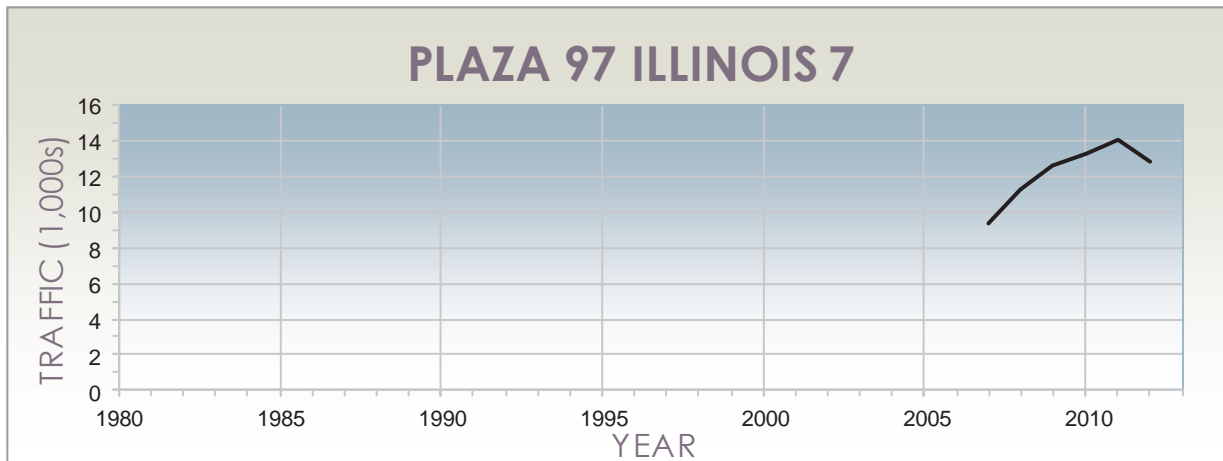

FIGURE 5-T

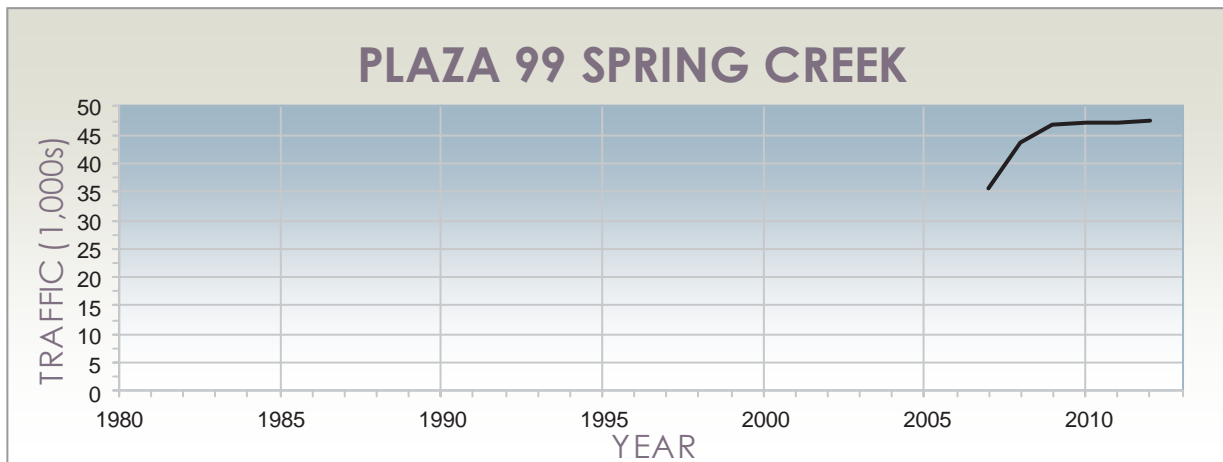
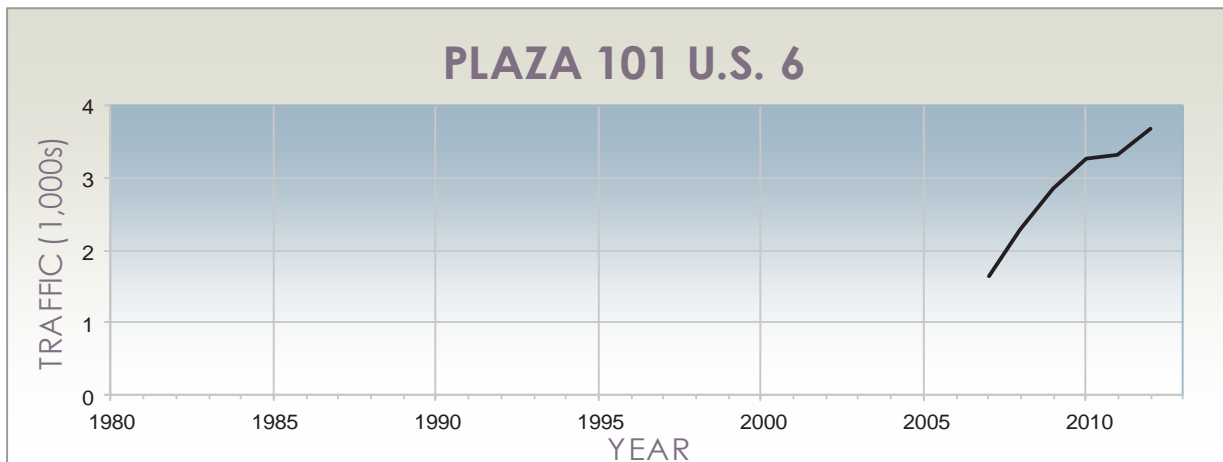

FIGURE 5-U



AVERAGE DAILY TRAFFIC TRENDS

Appendices Tab



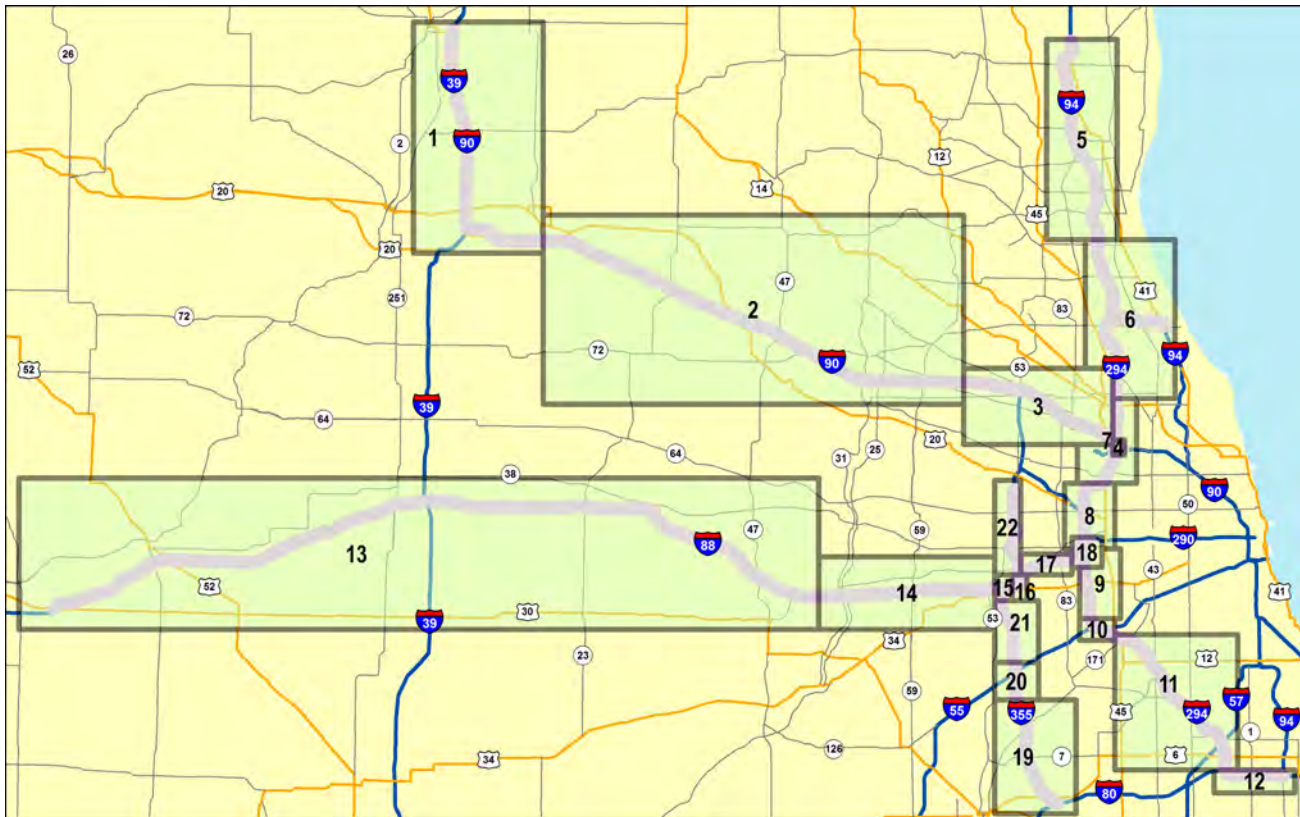

Jane Addams Memorial Tollway

- 1 – From Rockton Road to Genoa Road
- 2 – From US 20, Marengo to Barrington Road
- 3 – From Roselle Road to Devon Avenue
- 4 – From Tri-State Tollway to Kennedy Expressway

Tri-State Tollway

- 5 – From Russell Road to Lake Forest Oasis
- 6 – From Town Line Road to Golf Road and Edens Spur
- 7 – From Dempster Street to O'Hare Oasis
- 8 – From North Avenue / Lake Street to Reagan Memorial Tollway (I-88)
- 9 – From Roosevelt Road to Hinsdale Oasis
- 10 – From Joliet Road to Willow Springs Road
- 11 – From Archer / La Grange / 79th Street to 163rd Street
- 12 – From Interstate 80 to Bishop Ford / Kingery Expressway

Reagan Memorial Tollway

- 13 – From Illinois 26 to Orchard Road
- 14 – From Illinois 31 to Illinois 53
- 15 – Veterans Memorial Tollway West Interchange
- 16 – Veterans Memorial Tollway East Interchange
- 17 – From Highland Avenue to Harger Road
- 18 – From Roosevelt Road to Eisenhower Expressway (I-290)

Veterans Memorial Tollway

- 19 – From Interstate 80 to 127th Street
- 20 – At Interstate 55
- 21 – From Boughton Road To Maple Avenue
- 22 – From Ogden Avenue to Army Trail Road



Appendix A Tab





2012 Annual Average Daily Traffic

On Jane Addams Memorial Tollway, from Rockton Road to Genoa Road

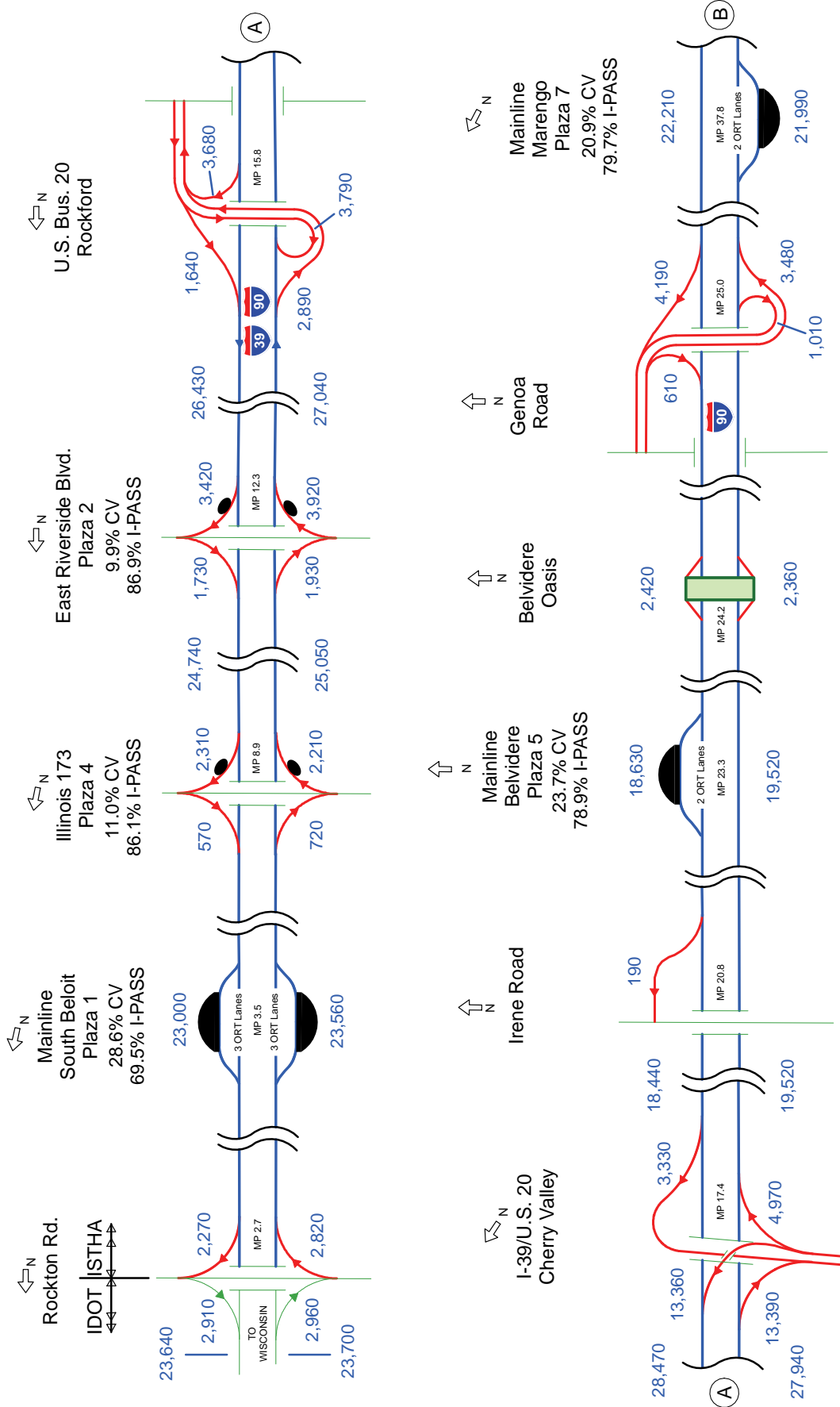

CV = Commercial Vehicles
 I-PASS = I-PASS Electronic Toll Collection
 ORT = Open Road Tolling Lanes
 AET = All Electronic Tolling





2012 Annual Average Daily Traffic

On Jane Addams Memorial Tollway, from U.S. 20, Marengo to Barrington Road

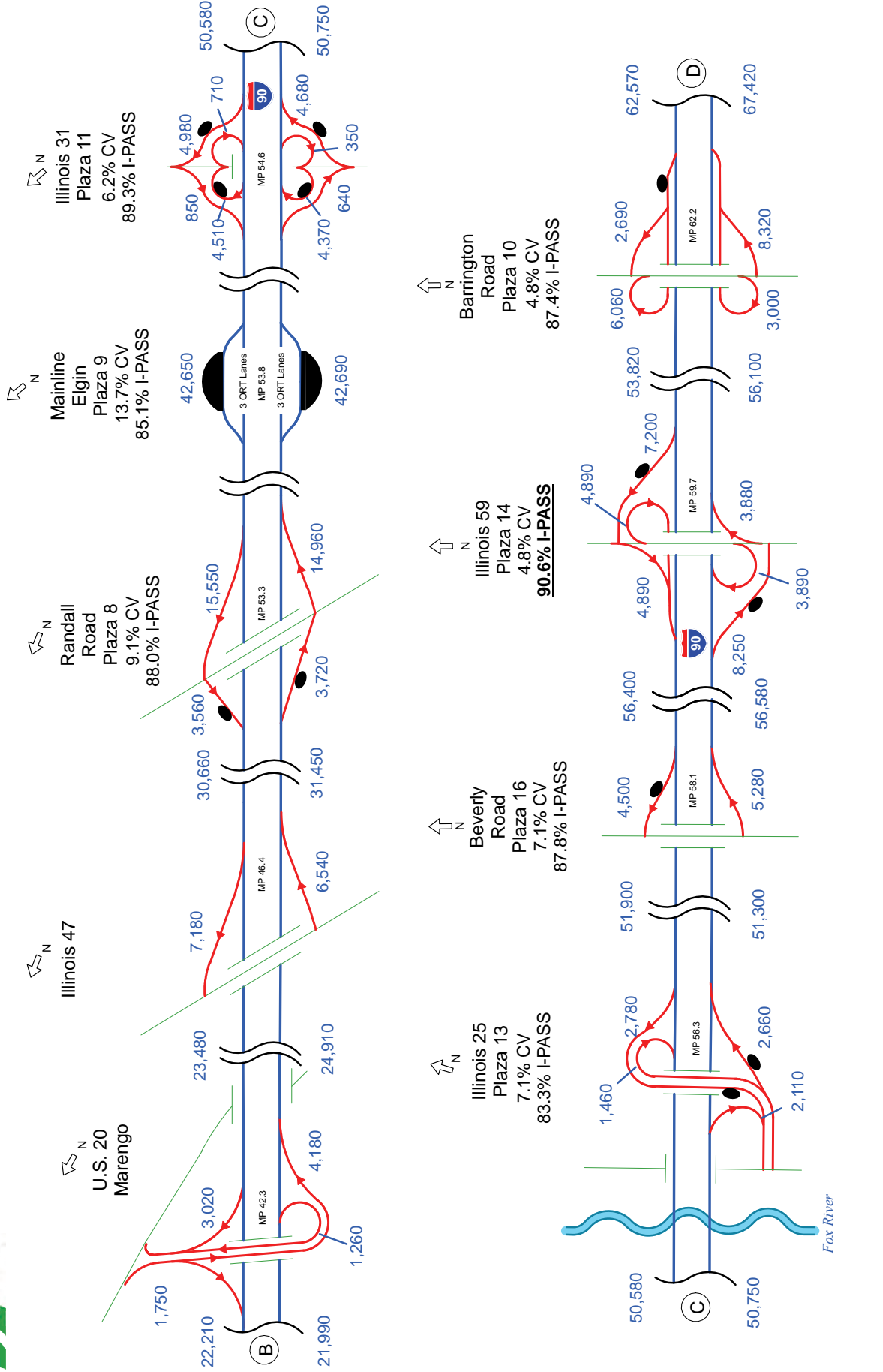

CV = Commercial Vehicles
 I-PASS = I-PASS Electronic Toll Collection
 ORT = Open Road Tolling Lanes
 AET = All Electronic Tolling





2012 Annual Average Daily Traffic

On Jane Addams Memorial Tollway, from Roselle Road to Devon Avenue

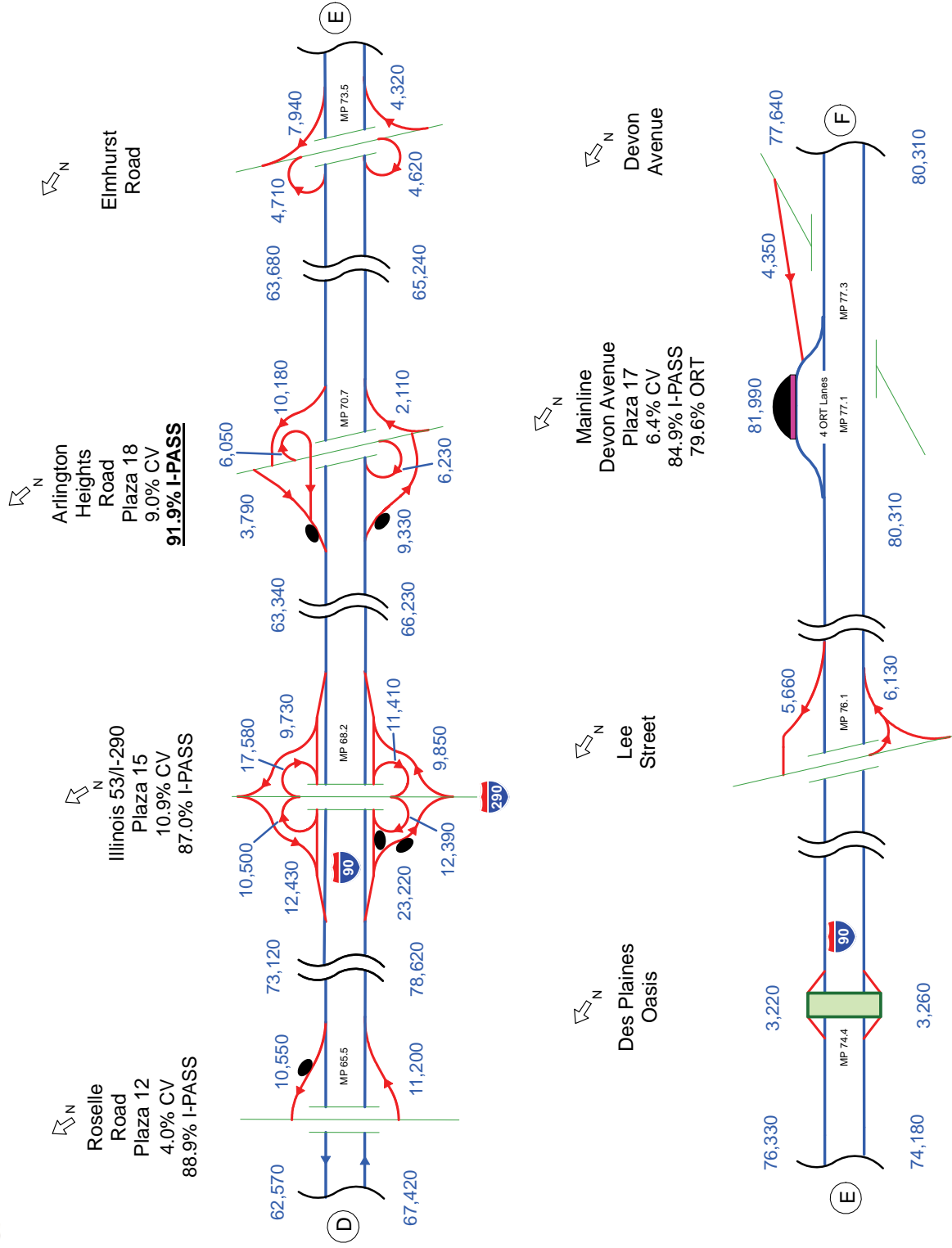

CV = Commercial Vehicles
 I-PASS = I-PASS Electronic Toll Collection
 ORT = Open Road Tolling Lanes
 AET = All Electronic Tolling





2012 Annual Average Daily Traffic

On Jane Addams Memorial Tollway, from Tri-State Tollway to Kennedy Expressway

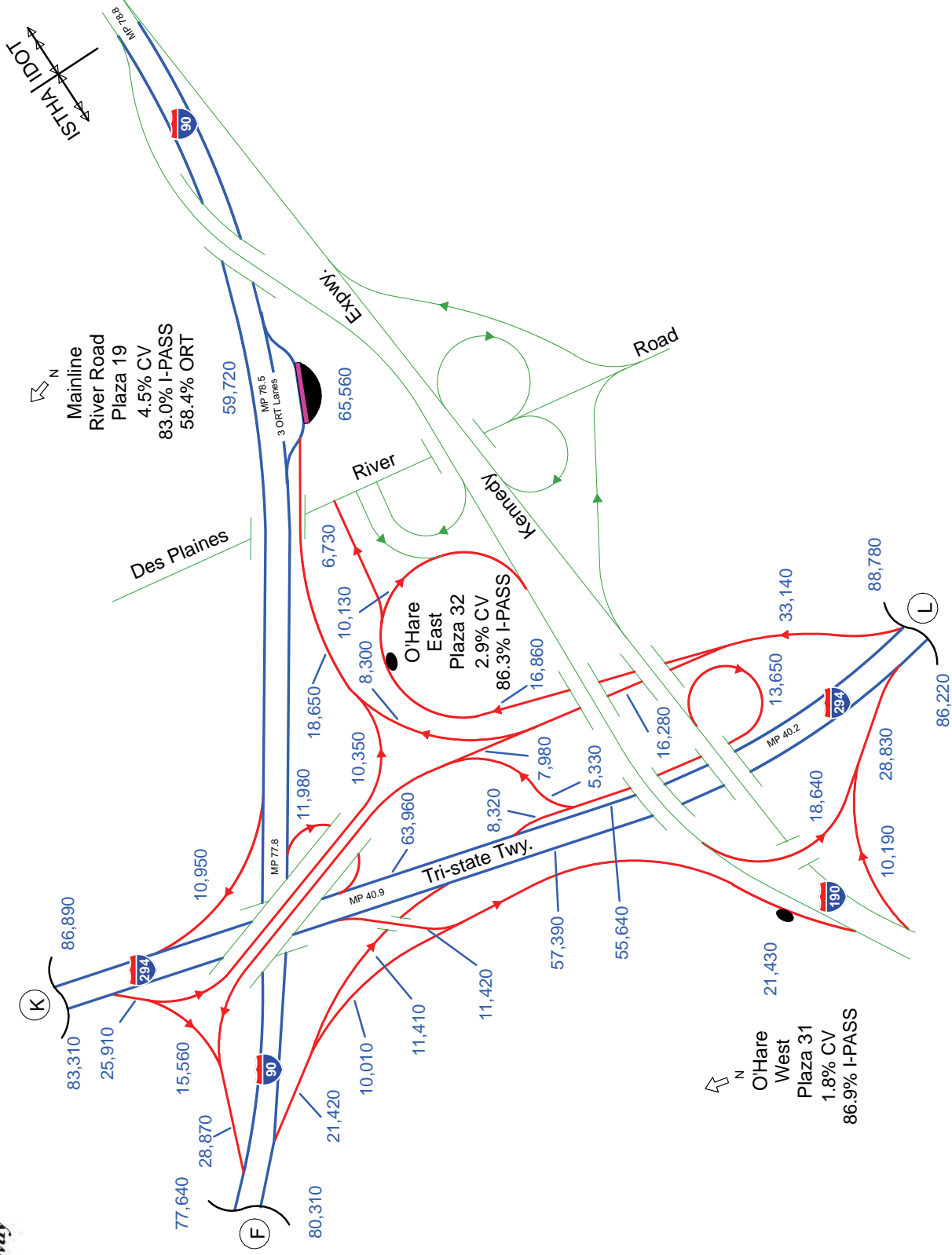

CV = Commercial Vehicles
 I-PASS = I-PASS Electronic Toll Collection
 ORT = Open Road Tolling Lanes
 AET = All Electronic Tolling





2012 Annual Average Daily Traffic

On Tri-State Tollway, from Russell Road to Lake Forest Oasis

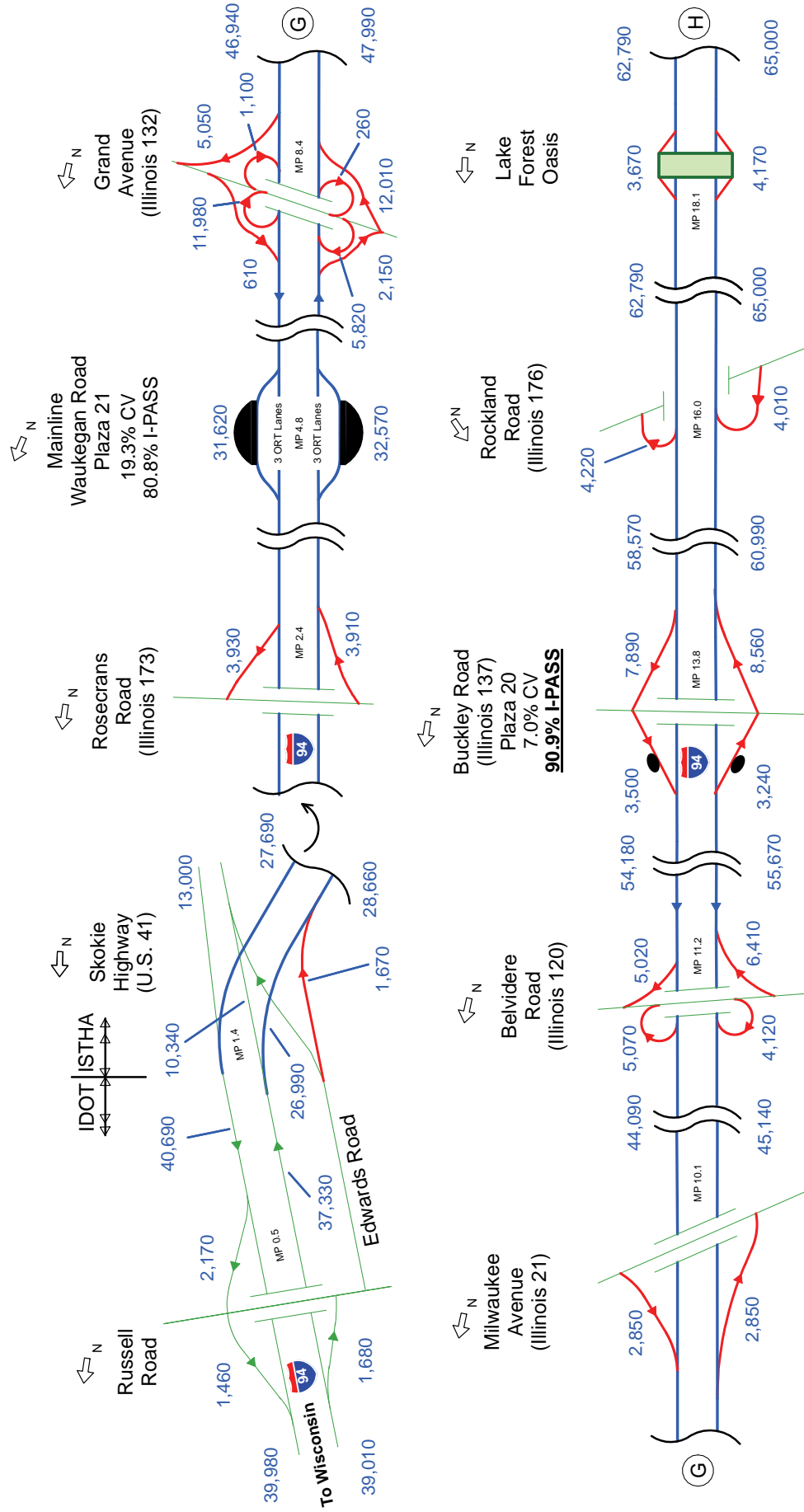

CV = Commercial Vehicles
 I-PASS = I-PASS Electronic Toll Collection
 ORT = Open Road Tolling Lanes
 AET = All Electronic Tolling





2012 Annual Average Daily Traffic

On Tri-State Tollway, from Town Line Road (Illinois 60) to Golf Road (Illinois 58) and Edens Spur

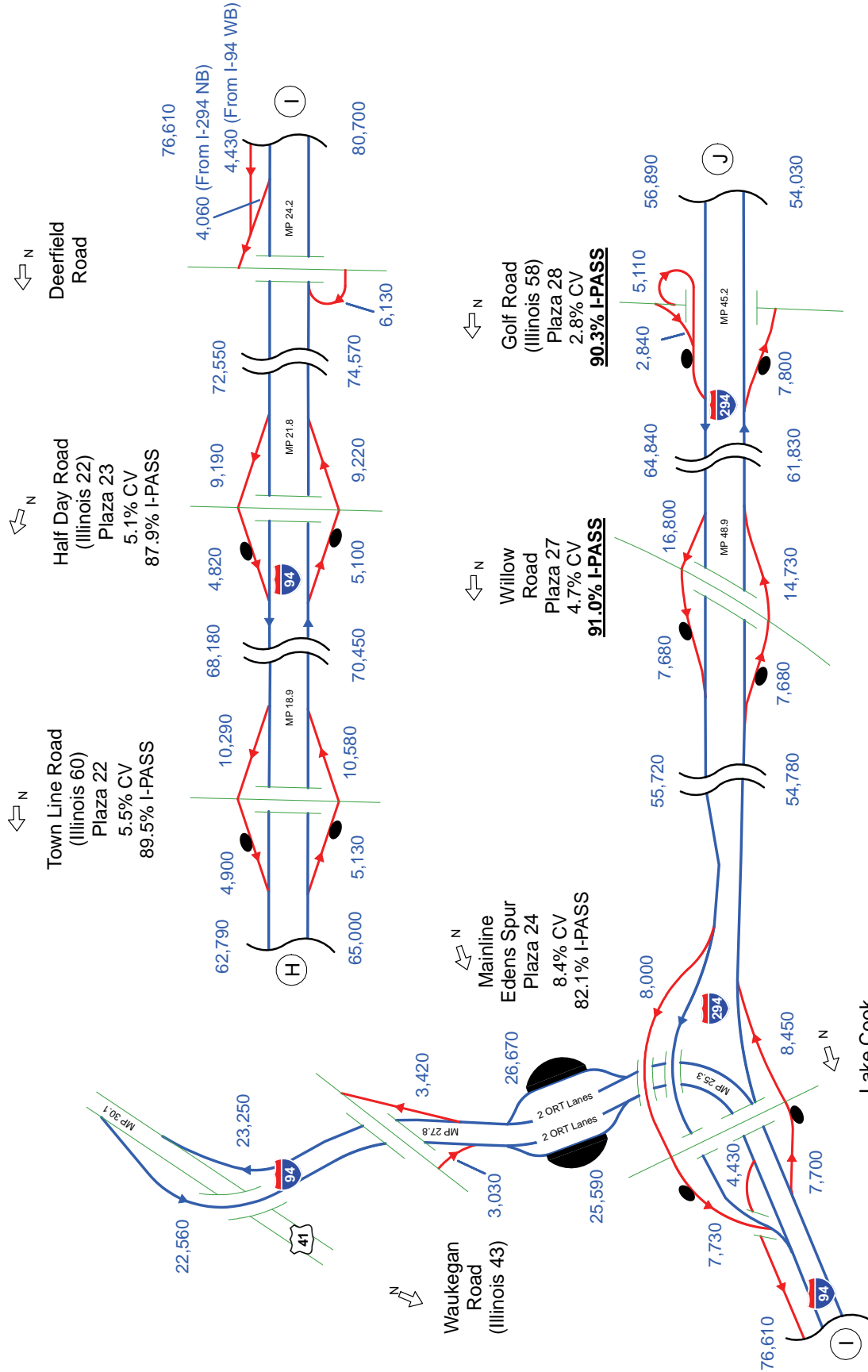

CV = Commercial Vehicles
 I-PASS = I-PASS Electronic Toll Collection
 ORT = Open Road Tolling Lanes
 AET = All Electronic Tolling





2012 Annual Average Daily Traffic

On Tri-State Tollway, from Dempster Street to O'Hare Oasis

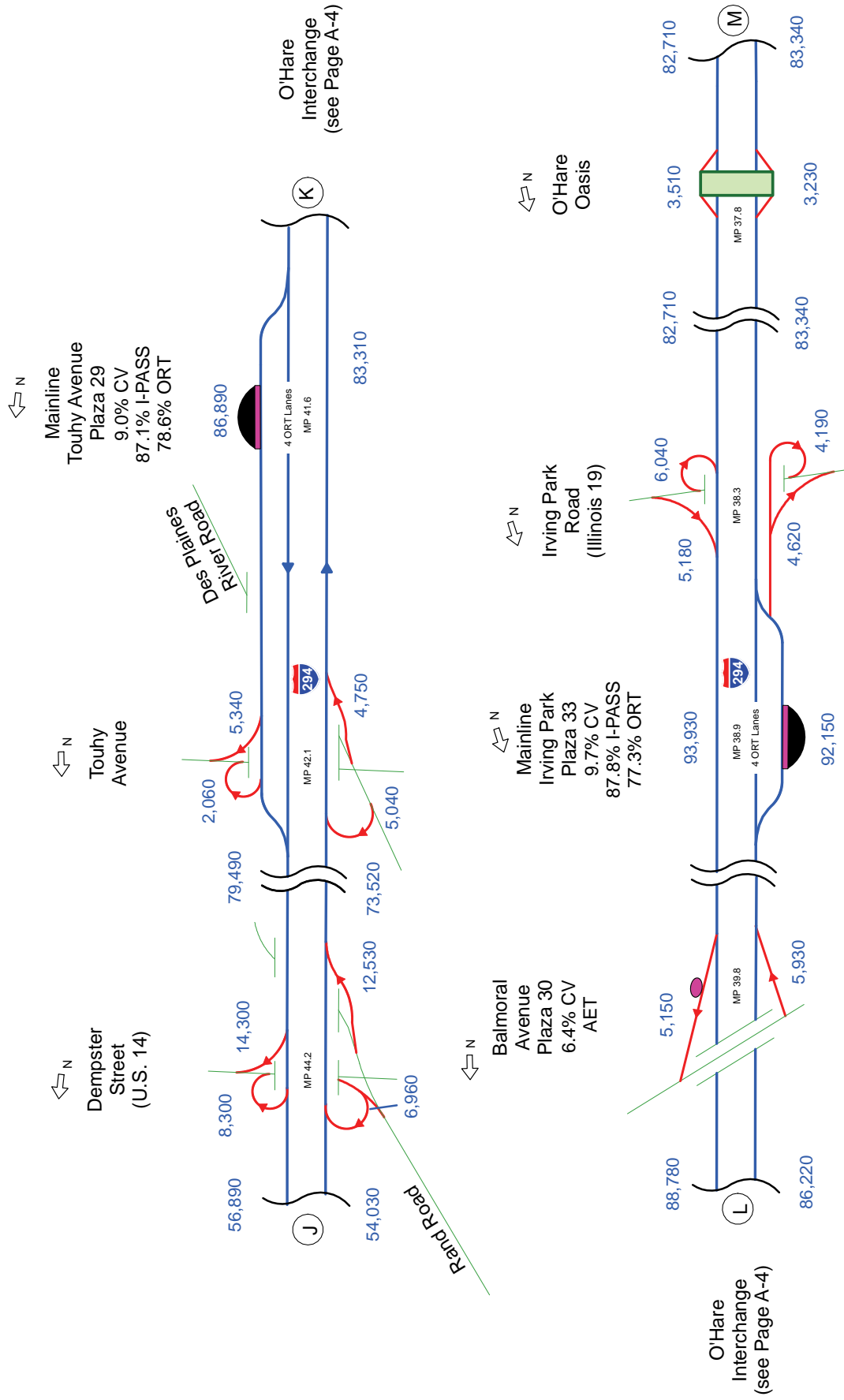

CV = Commercial Vehicles
 I-PASS = I-PASS Electronic Toll Collection
 ORT = Open Road Tolling Lanes
 AET = All Electronic Tolling





2012 Annual Average Daily Traffic

On Tri-State Tollway, from North Avenue / Lake Street to Reagan Memorial Tollway I-88

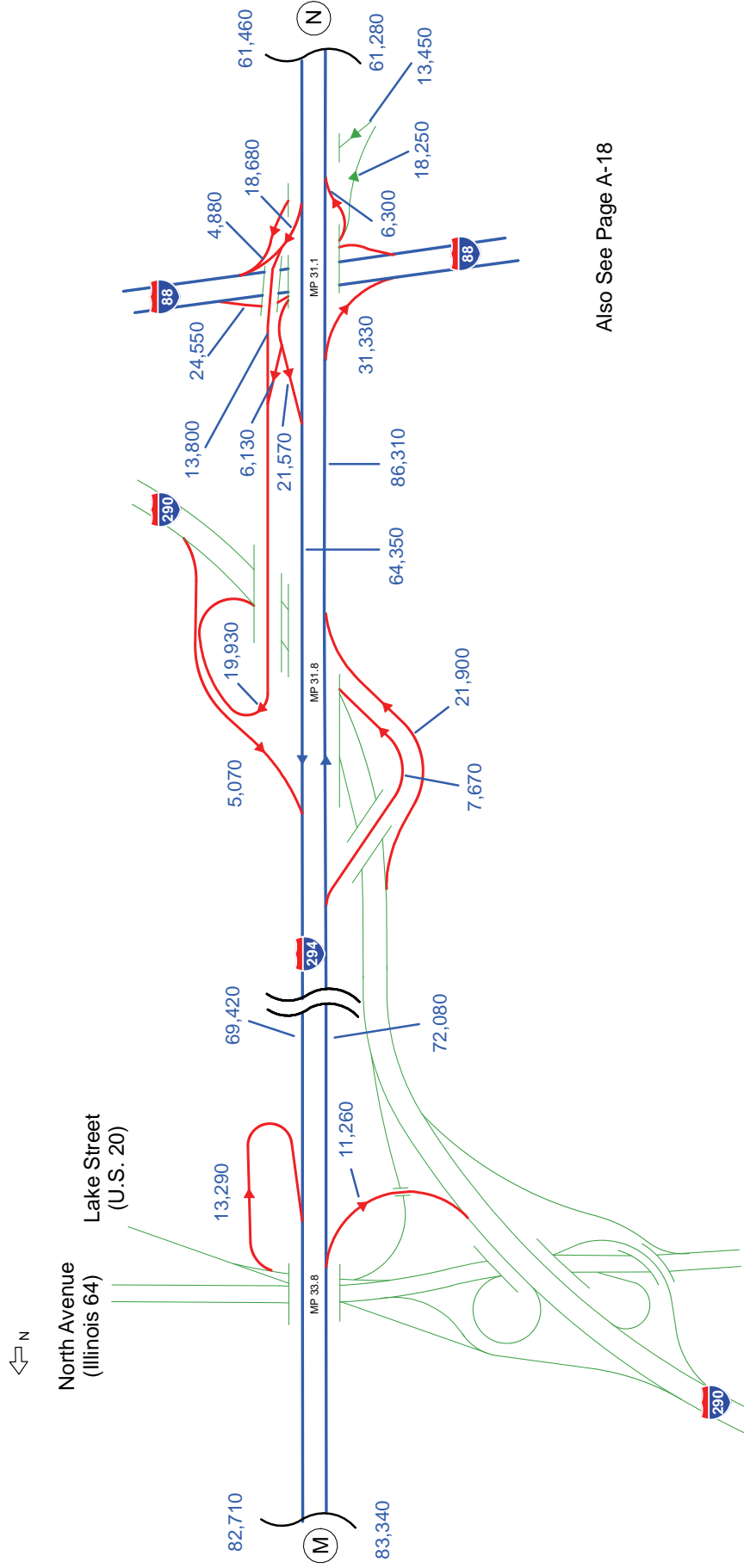

Also See Page A-18

CV = Commercial Vehicles
I-PASS = I-PASS Electronic Toll Collection
ORT = Open Road Tolling Lanes
AET = All Electronic Tolling





2012 Annual Average Daily Traffic

On Tri-State Tollway, from Roosevelt Road to Hinsdale Oasis

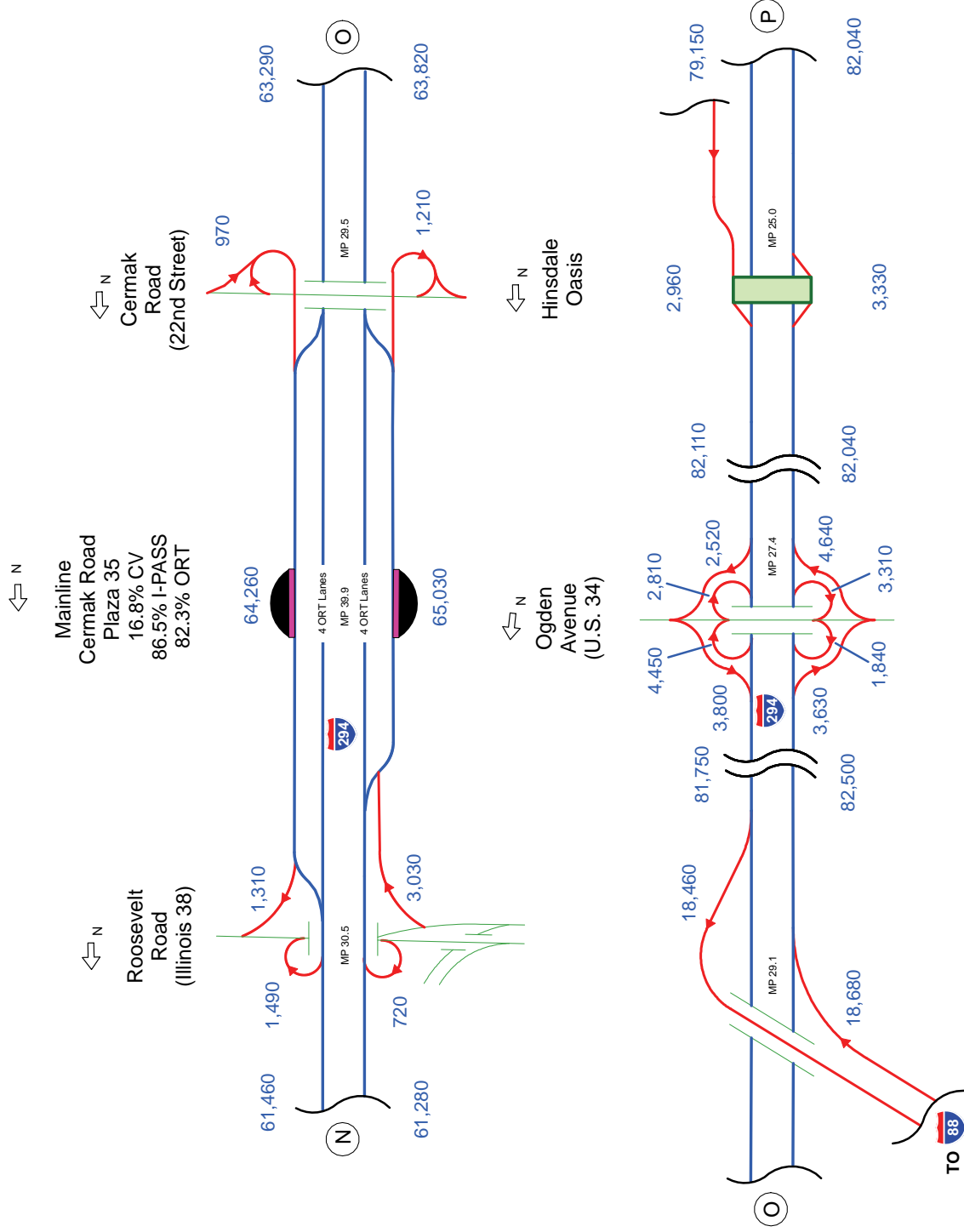

Also See Page A-17

CV = Commercial Vehicles
 I-PASS = I-PASS Electronic Toll Collection
 ORT = Open Road Tolling Lanes
 AET = All Electronic Tolling





2012 Annual Average Daily Traffic

On Tri-State Tollway, from Joliet Road (Plaza 37) to Willow Springs Road (Plaza 34)

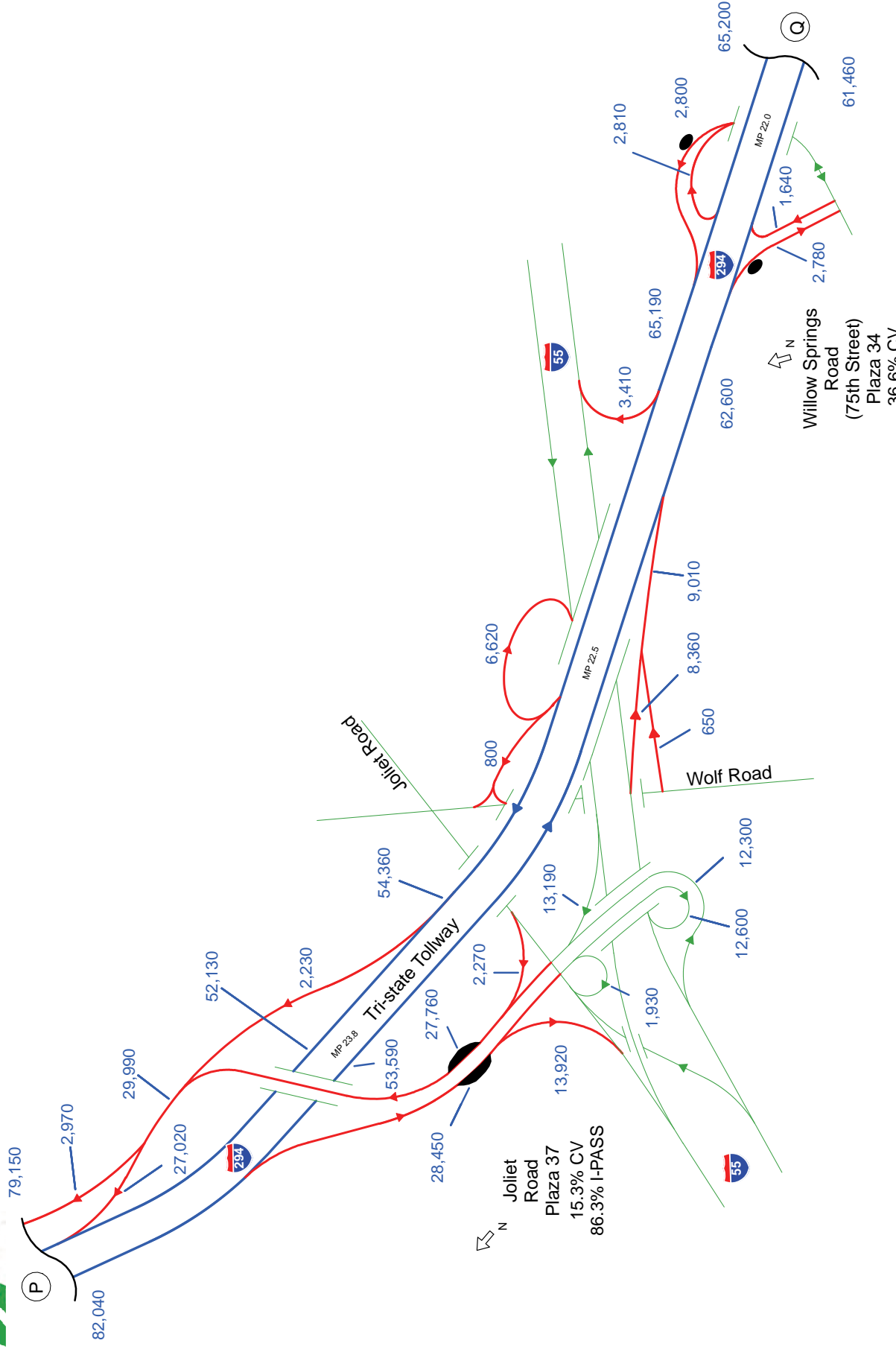

CV = Commercial Vehicles
 I-PASS = I-PASS Electronic Toll Collection
 ORT = Open Road Tolling Lanes
 AET = All Electronic Tolling





2012 Annual Average Daily Traffic

On Tri-State Tollway, from Archer / Lagrange / 79th Street to 163rd Street (Plaza 41)

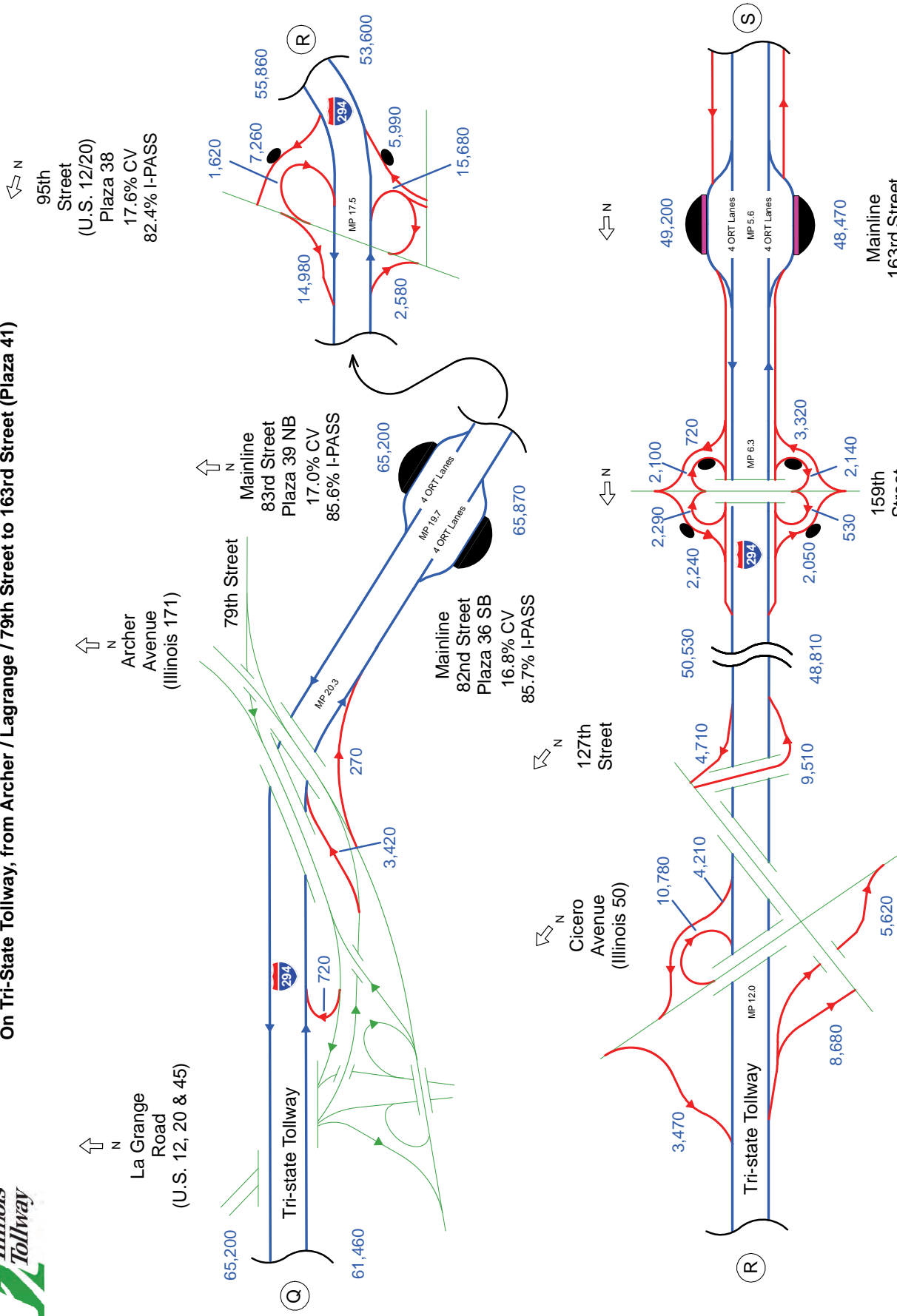

CV = Commercial Vehicles
 I-PASS = I-PASS Electronic Toll Collection
 ORT = Open Road Tolling Lanes
 AET = All Electronic Tolling





2012 Annual Average Daily Traffic

On Tri-State Tollway, from Interstate 80 to Bishop Ford / Kingery Expressway

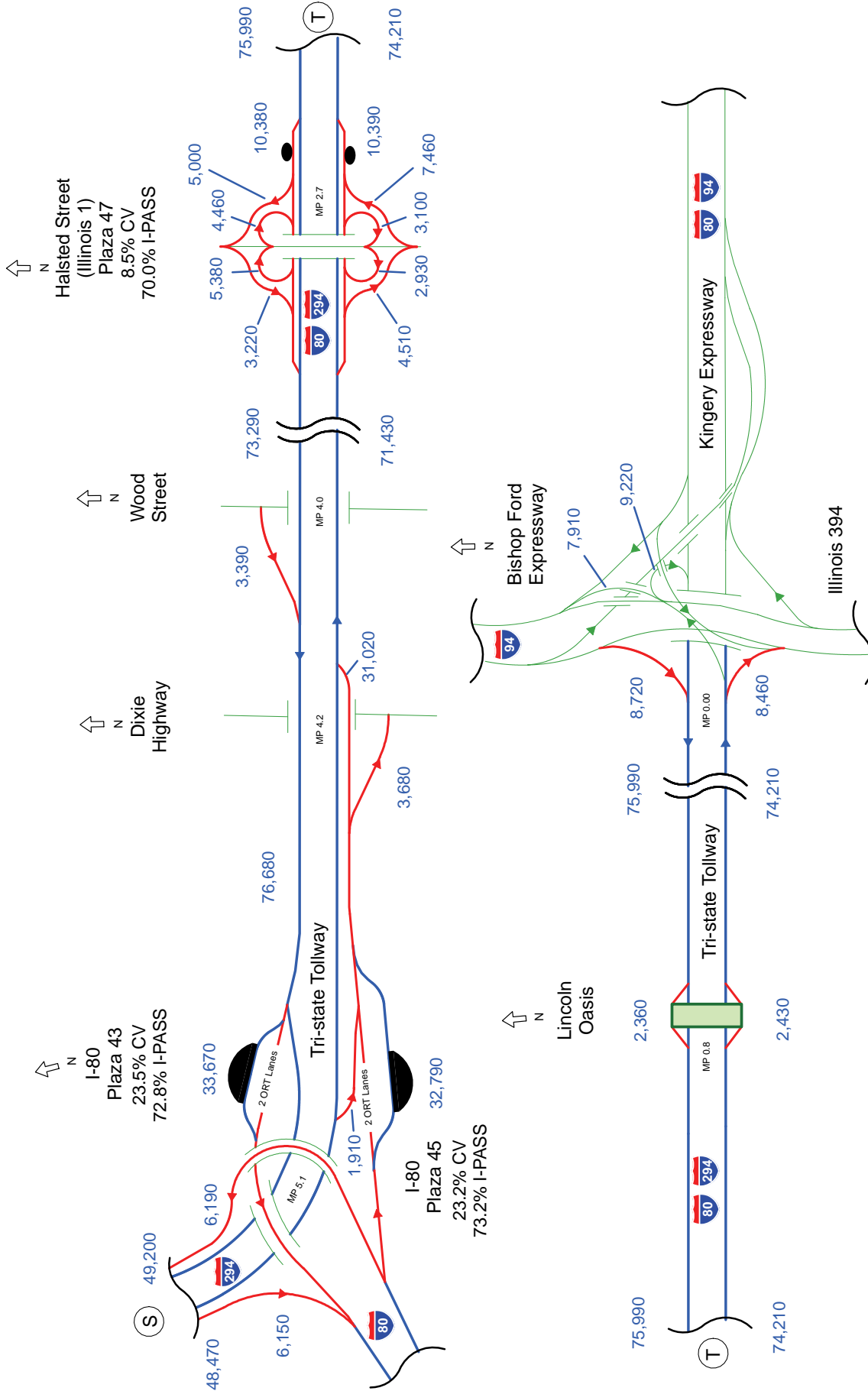

ISTHA IDOT

CV = Commercial Vehicles
 I-PASS = I-PASS Electronic Toll Collection
 ORT = Open Road Tolling Lanes
 AET = All Electronic Tolling





2012 Annual Average Daily Traffic

On Reagan Memorial Tollway, from Illinois 26 to Orchard Road

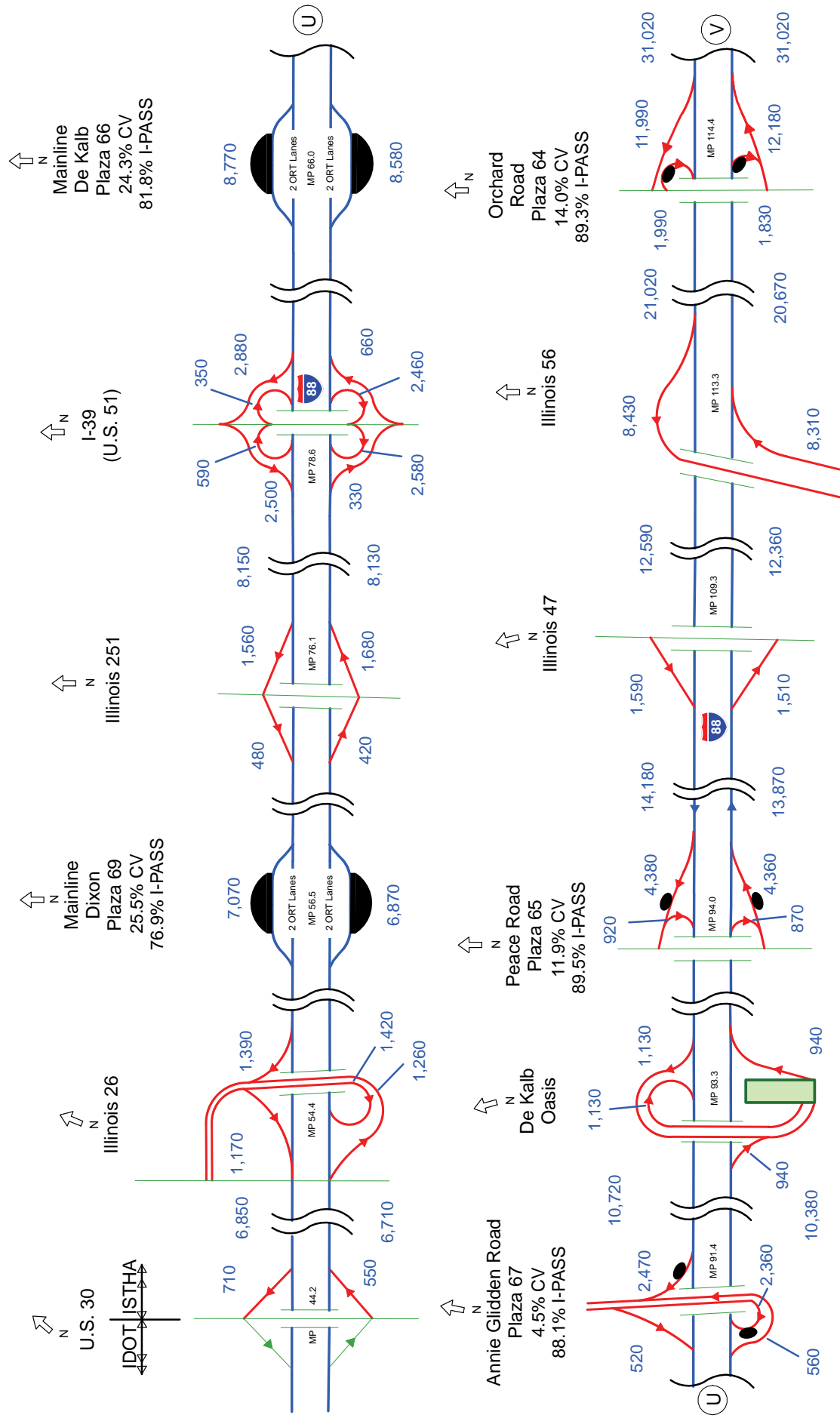

CV = Commercial Vehicles
 I-PASS = I-PASS Electronic Toll Collection
 ORT = Open Road Tolling Lanes
 AET = All Electronic Tolling





2012 Annual Average Daily Traffic

On Reagan Memorial Tollway, from Illinois 31 to Illinois 53

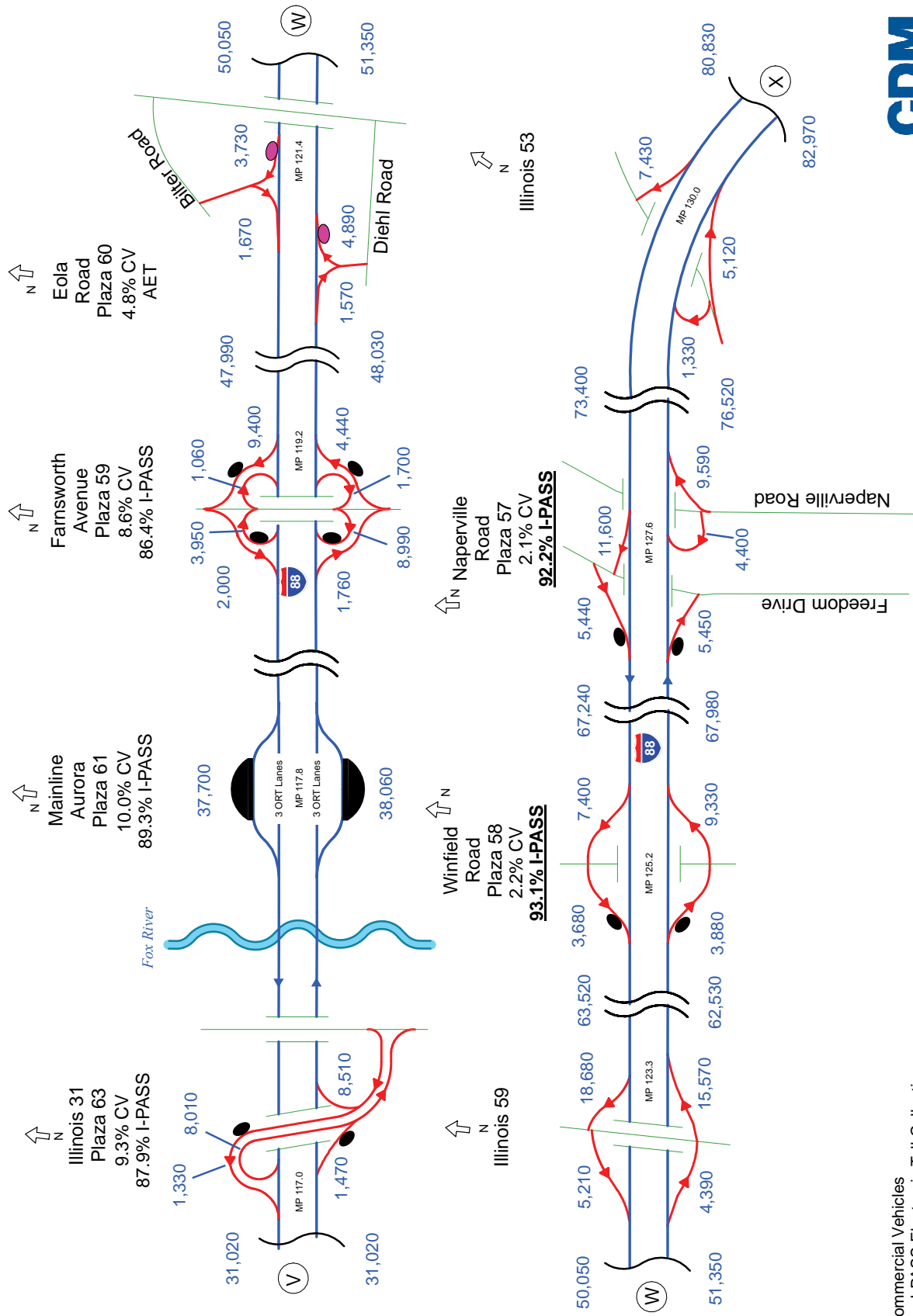

CV = Commercial Vehicles
 I-PASS = I-PASS Electronic Toll Collection
 ORT = Open Road Tolling Lanes
 AET = All Electronic Tolling





2012 Annual Average Daily Traffic

On Reagan Memorial Tollway, Veterans Memorial Tollway West Interchange

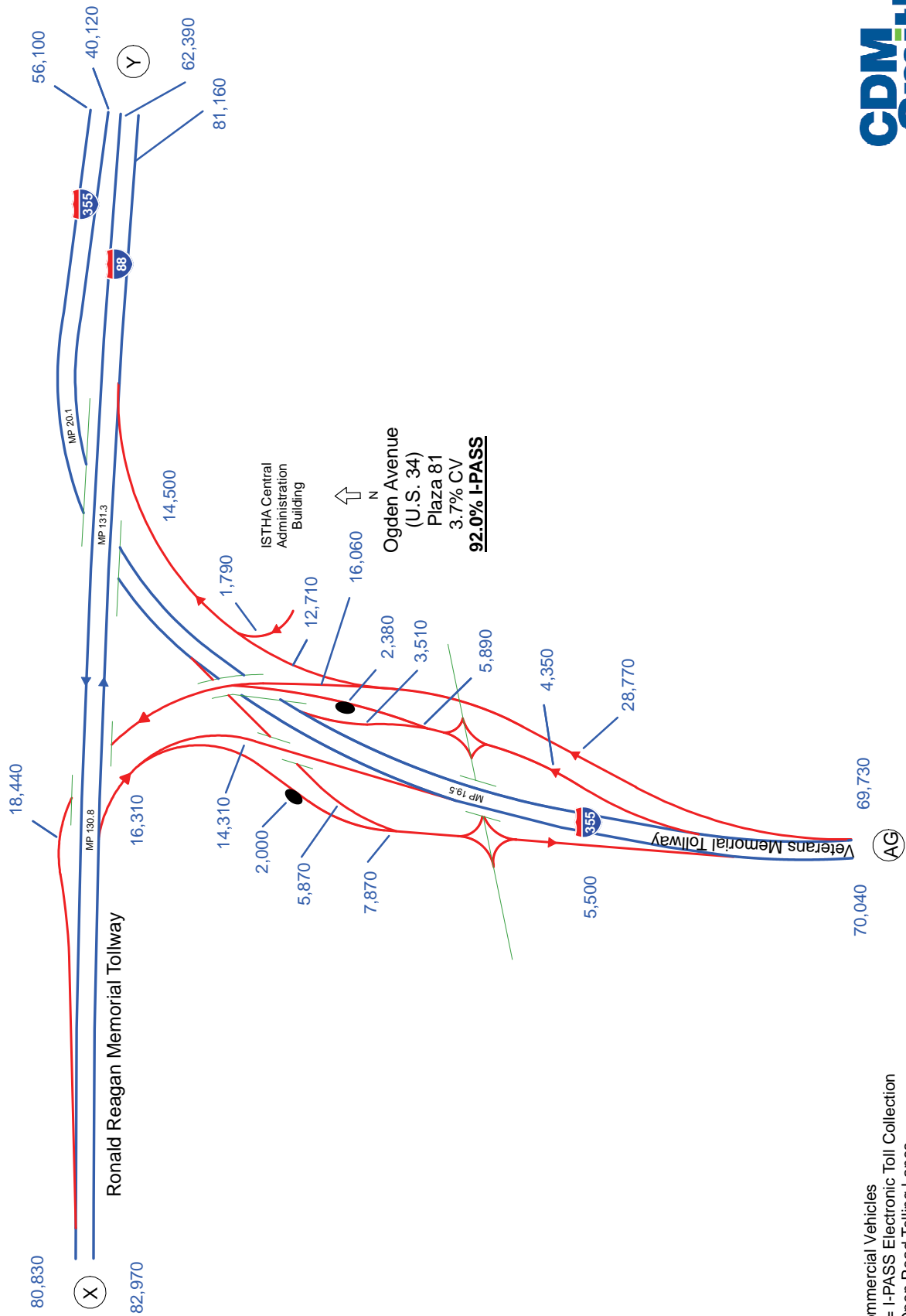

CV = Commercial Vehicles
 I-PASS = I-PASS Electronic Toll Collection
 ORT = Open Road Tolling Lanes
 AET = All Electronic Tolling





2012 Annual Average Daily Traffic

On Reagan Memorial Tollway, Veterans Memorial Tollway East Interchange

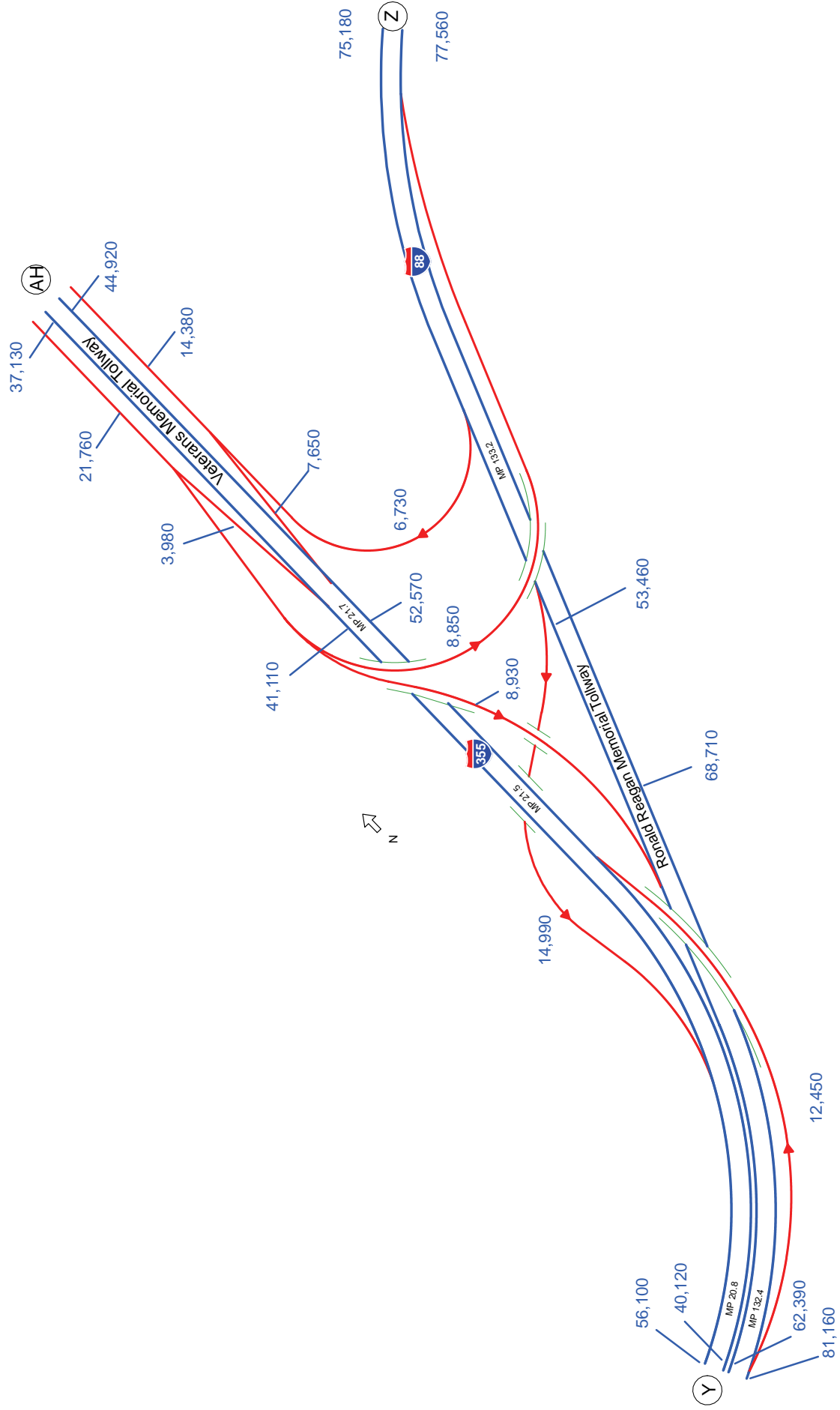

CV = Commercial Vehicles
 I-PASS = I-PASS Electronic Toll Collection
 ORT = Open Road Tolling Lanes
 AET = All Electronic Tolling





2012 Annual Average Daily Traffic

On Reagan Memorial Tollway, from Highland Avenue to Harger Road

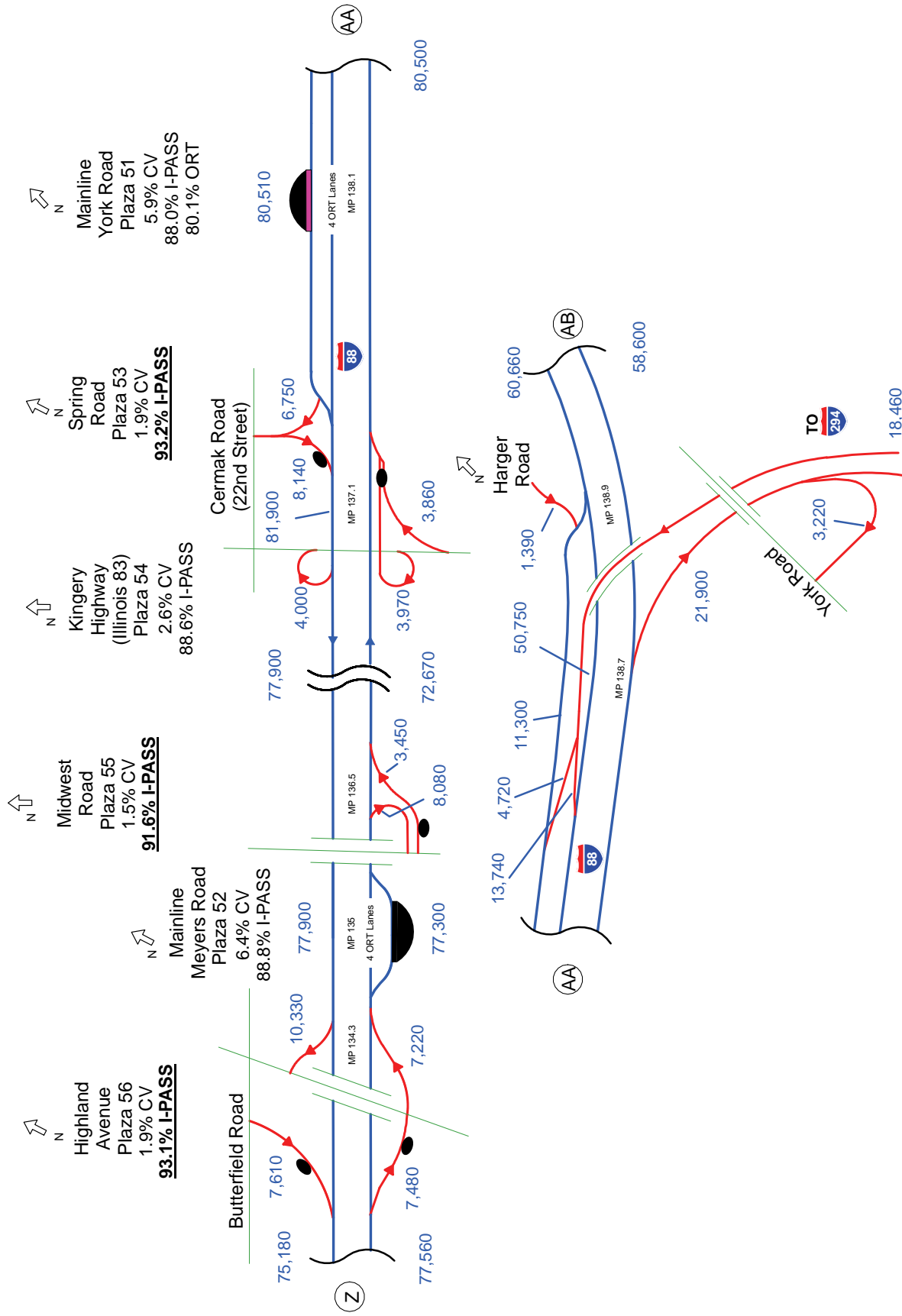

CV = Commercial Vehicles
 I-PASS = I-PASS Electronic Toll Collection
 ORT = Open Road Tolling Lanes
 AET = All Electronic Tolling

Also See Page A-9





2012 Annual Average Daily Traffic

On Reagan Memorial Tollway, from Roosevelt Road to Eisenhower Expressway, I-290

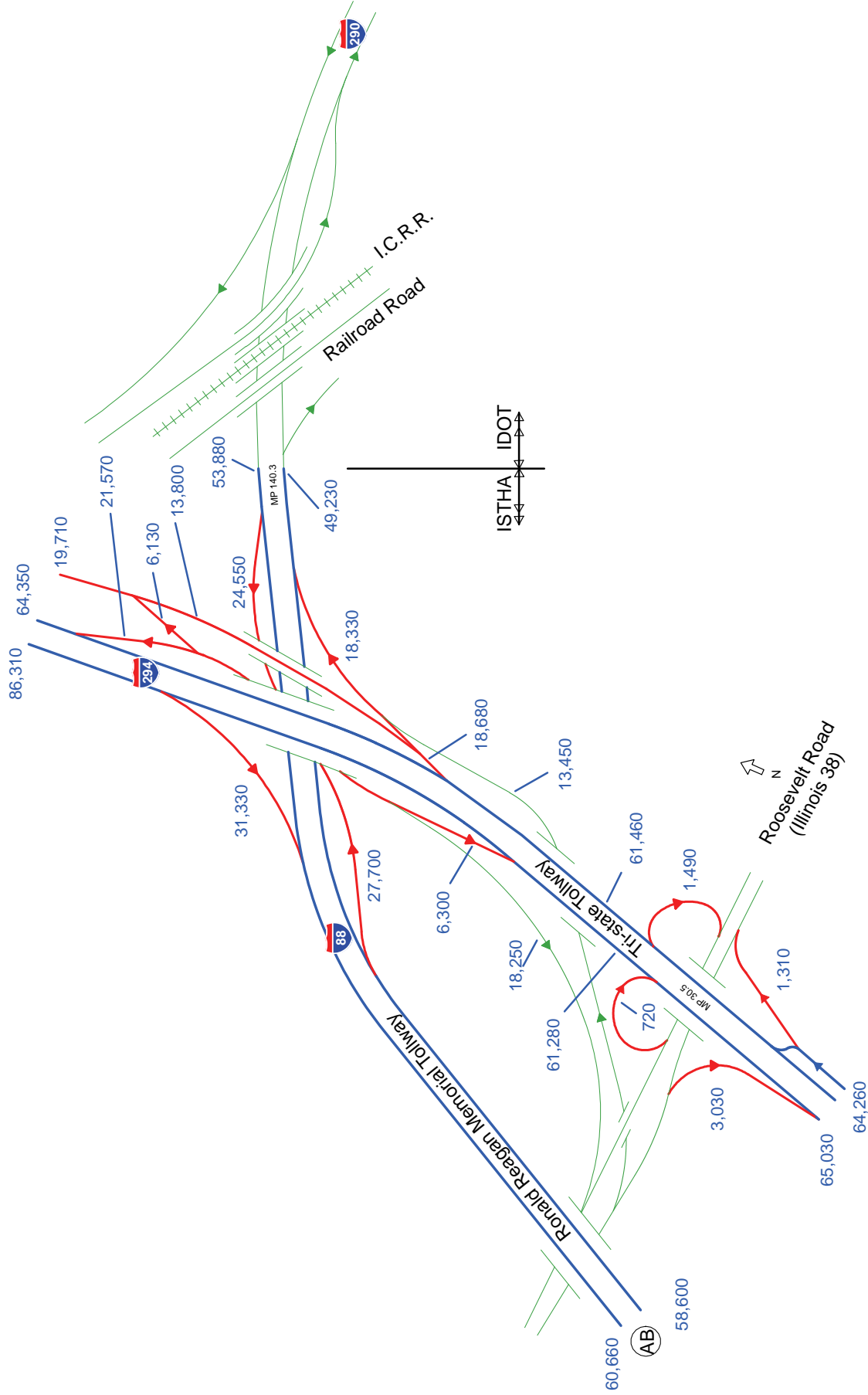

CV = Commercial Vehicles
 I-PASS = I-PASS Electronic Toll Collection
 ORT = Open Road Tolling Lanes
 AET = All Electronic Tolling





2012 Annual Average Daily Traffic On Veterans Memorial Tollway, from Interstate 80 to 127th Street

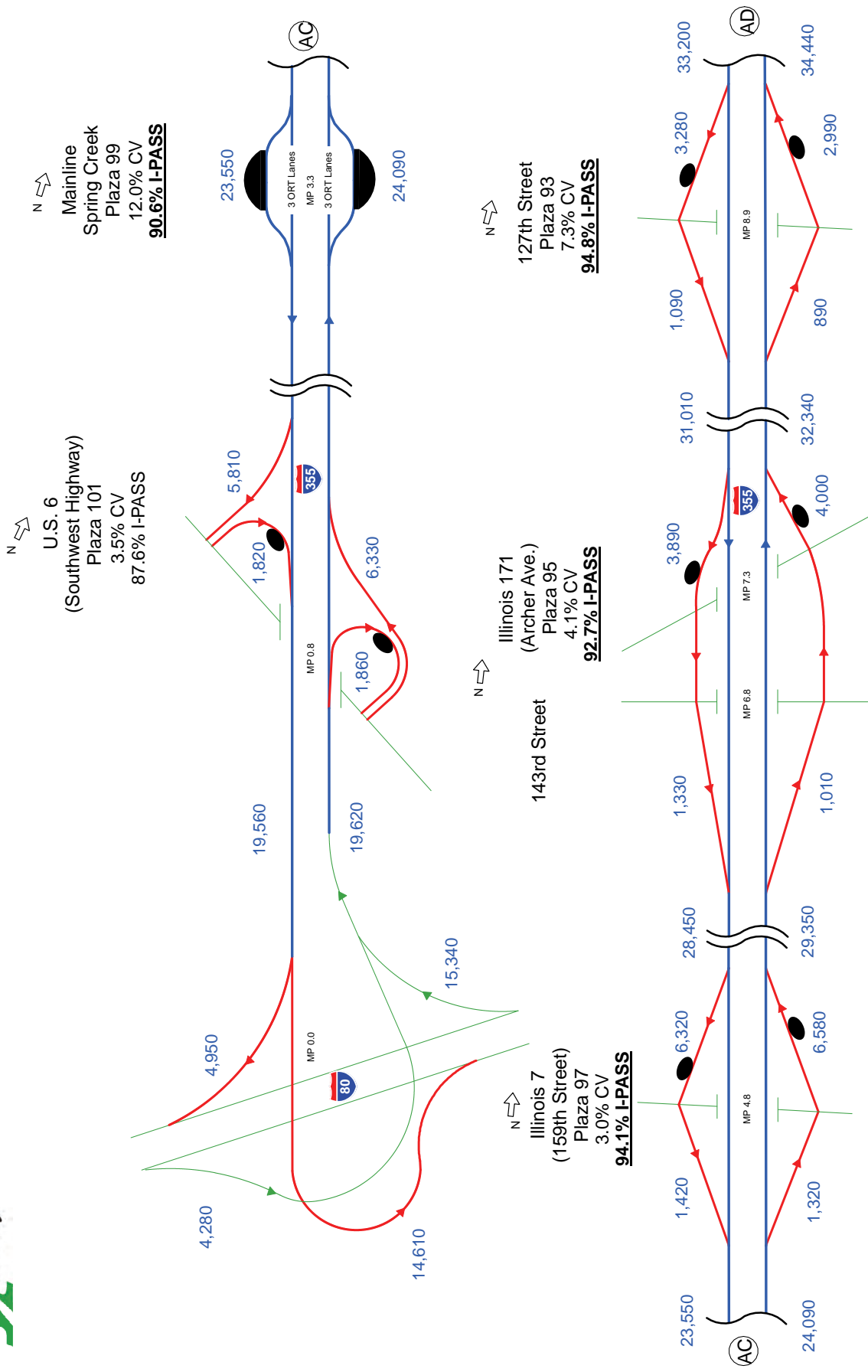

CV = Commercial Vehicles
 I-PASS = I-PASS Electronic Toll Collection
 ORT = Open Road Tolling Lanes
 AET = All Electronic Tolling





2012 Annual Average Daily Traffic

On Veterans Memorial Tollway, At Interstate 55

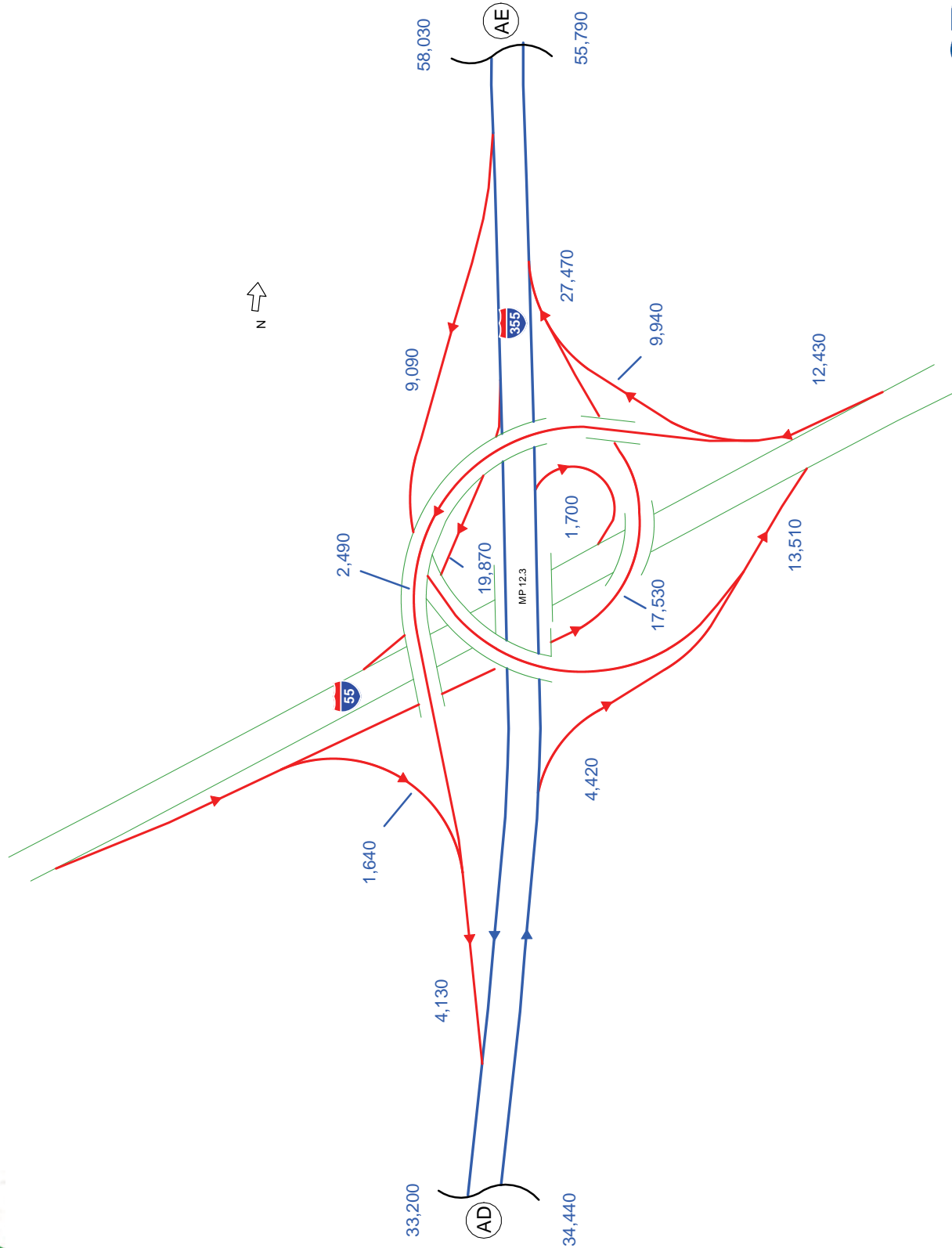

CV = Commercial Vehicles
 I-PASS = I-PASS Electronic Toll Collection
 ORT = Open Road Tolling Lanes
 AET = All Electronic Tolling





2012 Annual Average Daily Traffic

On Veterans Memorial Tollway, from Boughton Road to Maple Avenue

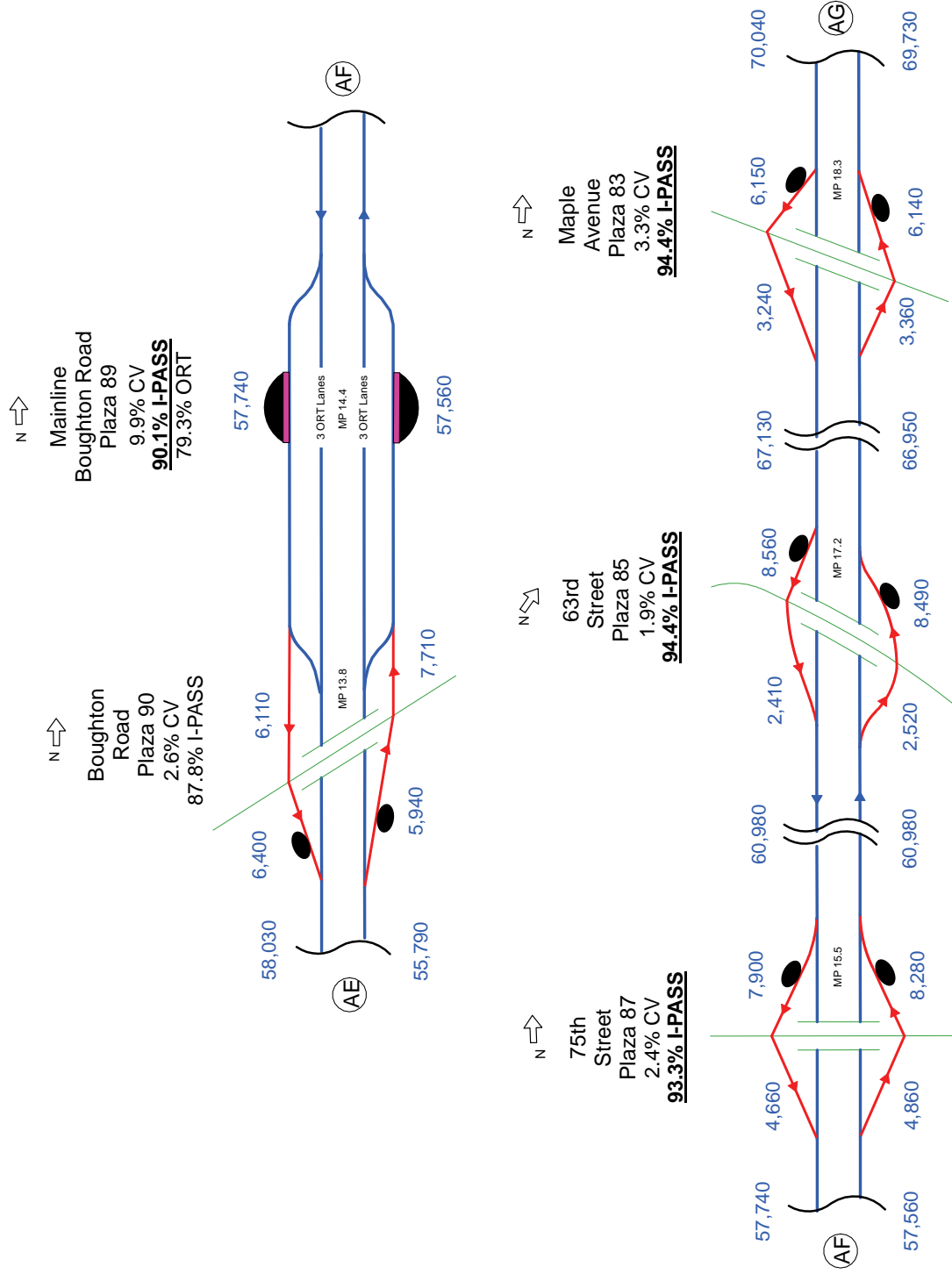

CV = Commercial Vehicles
 I-PASS = I-PASS Electronic Toll Collection
 ORT = Open Road Tolling Lanes
 AET = All Electronic Tolling





2012 Annual Average Daily Traffic On Veterans Memorial Tollway, from Ogden Avenue / West Interchange to Army Trail Road

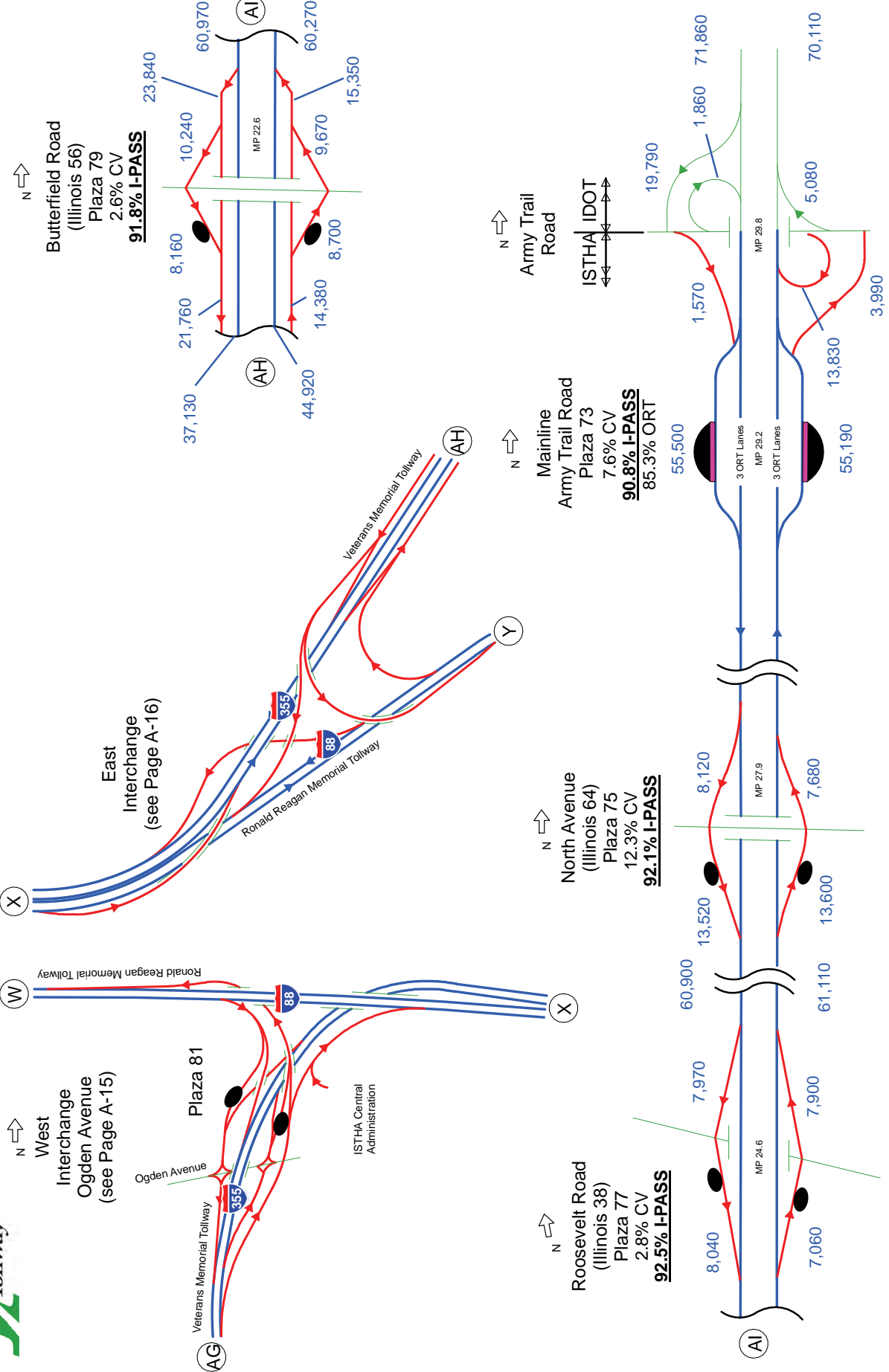

CV = Commercial Vehicles
 I-PASS = I-PASS Electronic Toll Collection
 ORT = Open Road Tolling Lanes
 AET = All Electronic Tolling



Appendix B Tab





2012 A.M. & P.M. Peak Hour Traffic

On Jane Addams Memorial Tollway, from Rockton Road to Genoa Road

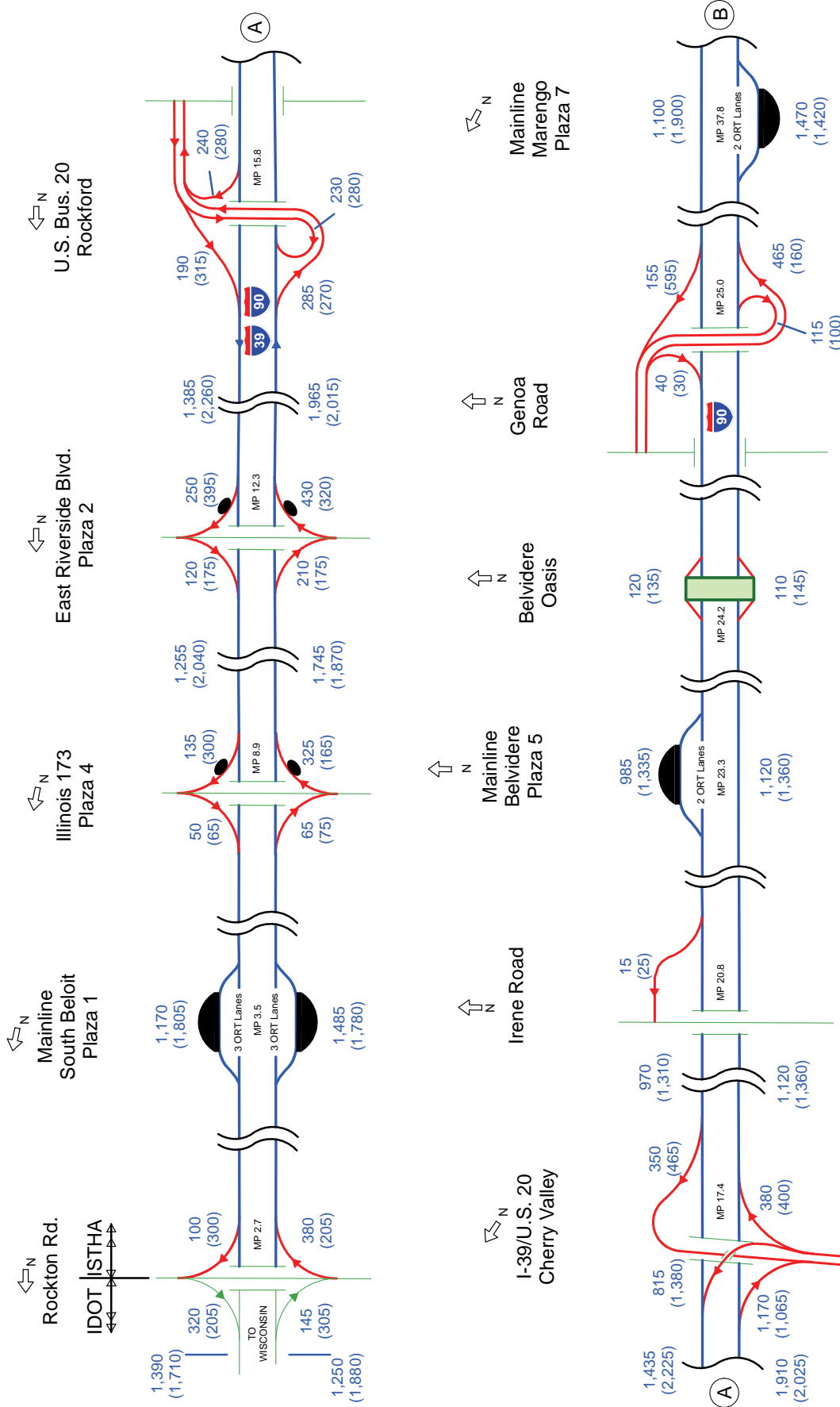

Note:
 The 2012 AM & PM peak-hour volumes are defined as the 85th Percentile volumes occurring in the 6:00 to 8:00 AM and the 4:00 to 6:00 PM periods respectively. Peak-hour volumes are calculated from Monday through Thursday hourly traffic volume data only, and exclude Holidays.

* ** = A.M. Peak
 (*, **) = P.M. Peak





2012 A.M. & P.M. Peak Hour Traffic

On Jane Addams Memorial Tollway, from U.S. 20, Marengo to Barrington Road

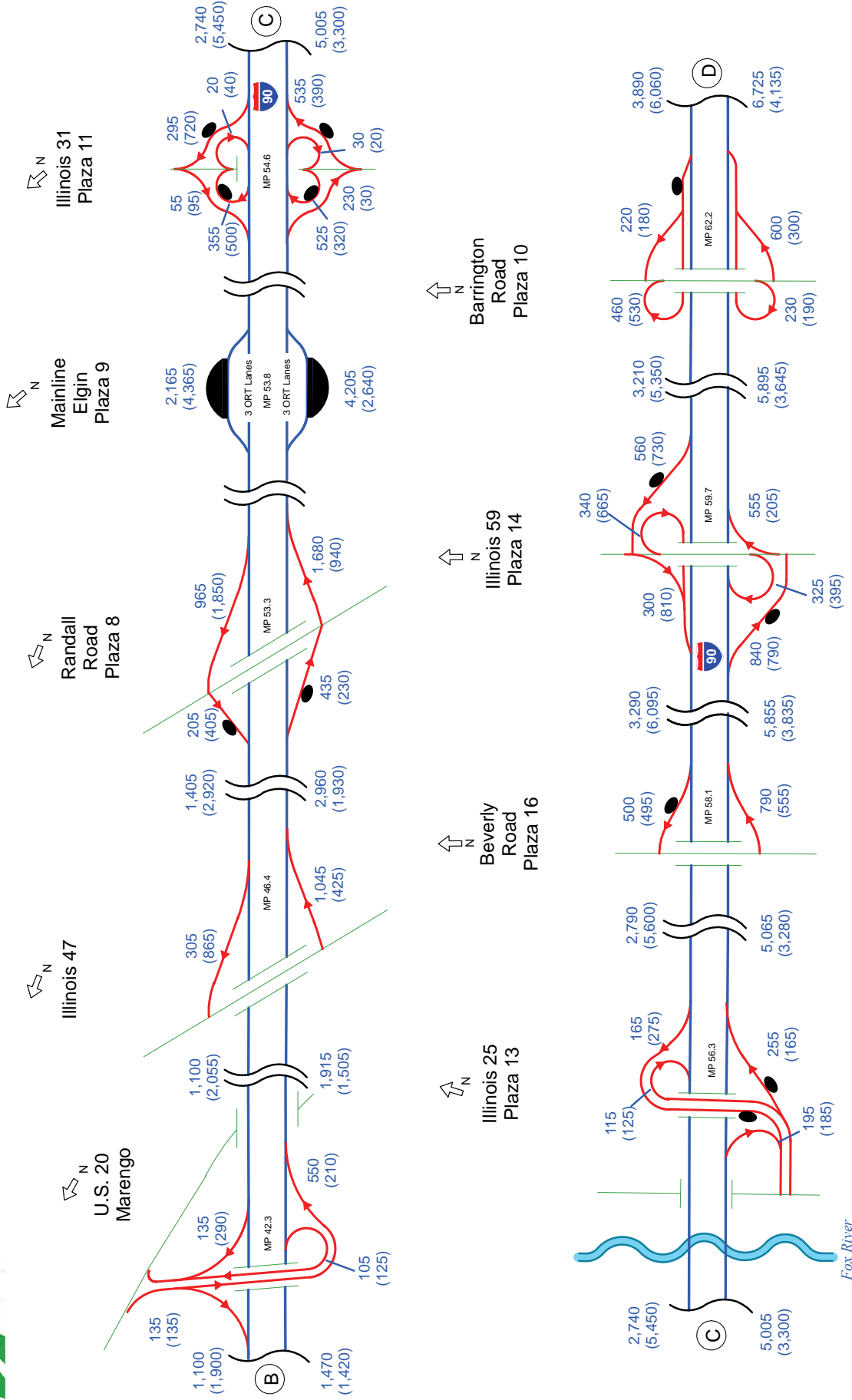

Note:
 The 2012 AM & PM peak-hour volumes are defined as the 85th Percentile volumes occurring in the 6:00 to 8:00 AM and the 4:00 to 6:00 PM periods respectively. Peak-hour volumes are calculated from Monday through Thursday hourly traffic volume data only, and exclude Holidays.

**** = A.M. Peak
 (*, ***) = P.M. Peak





2012 A.M. & P.M. Peak Hour Traffic

On Jane Addams Memorial Tollway, from Roselle Road to Devon Avenue

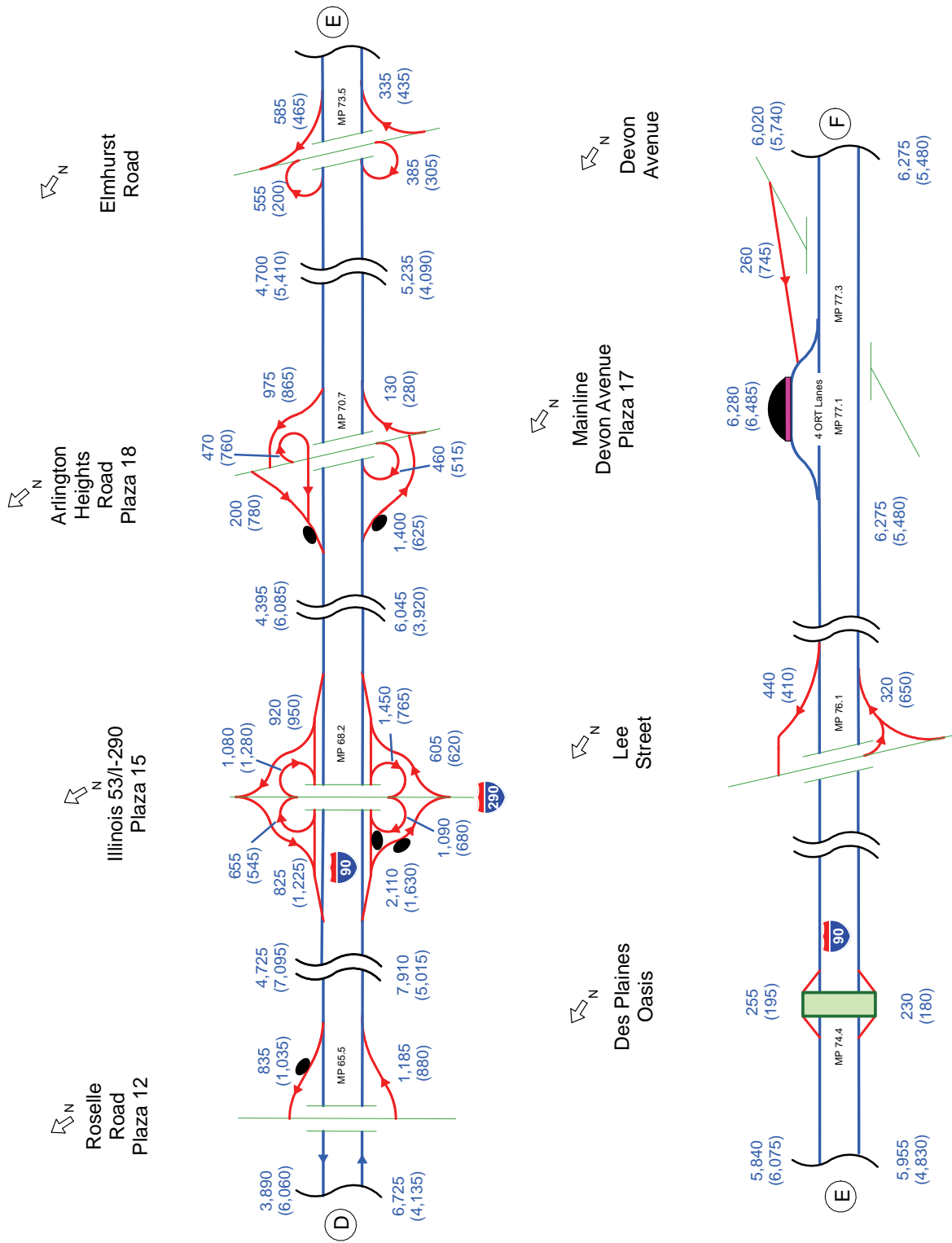

Note:
 The 2012 AM & PM peak-hour volumes are defined as the 85th Percentile volumes occurring in the 6:00 to 8:00 AM and the 4:00 to 6:00 PM periods respectively. Peak-hour volumes are calculated from Monday through Thursday hourly traffic volume data only, and exclude Holidays.





2012 A.M. & P.M. Peak Hour Traffic

On Jane Addams Memorial Tollway, from Tri-State Tollway to Kennedy Expressway

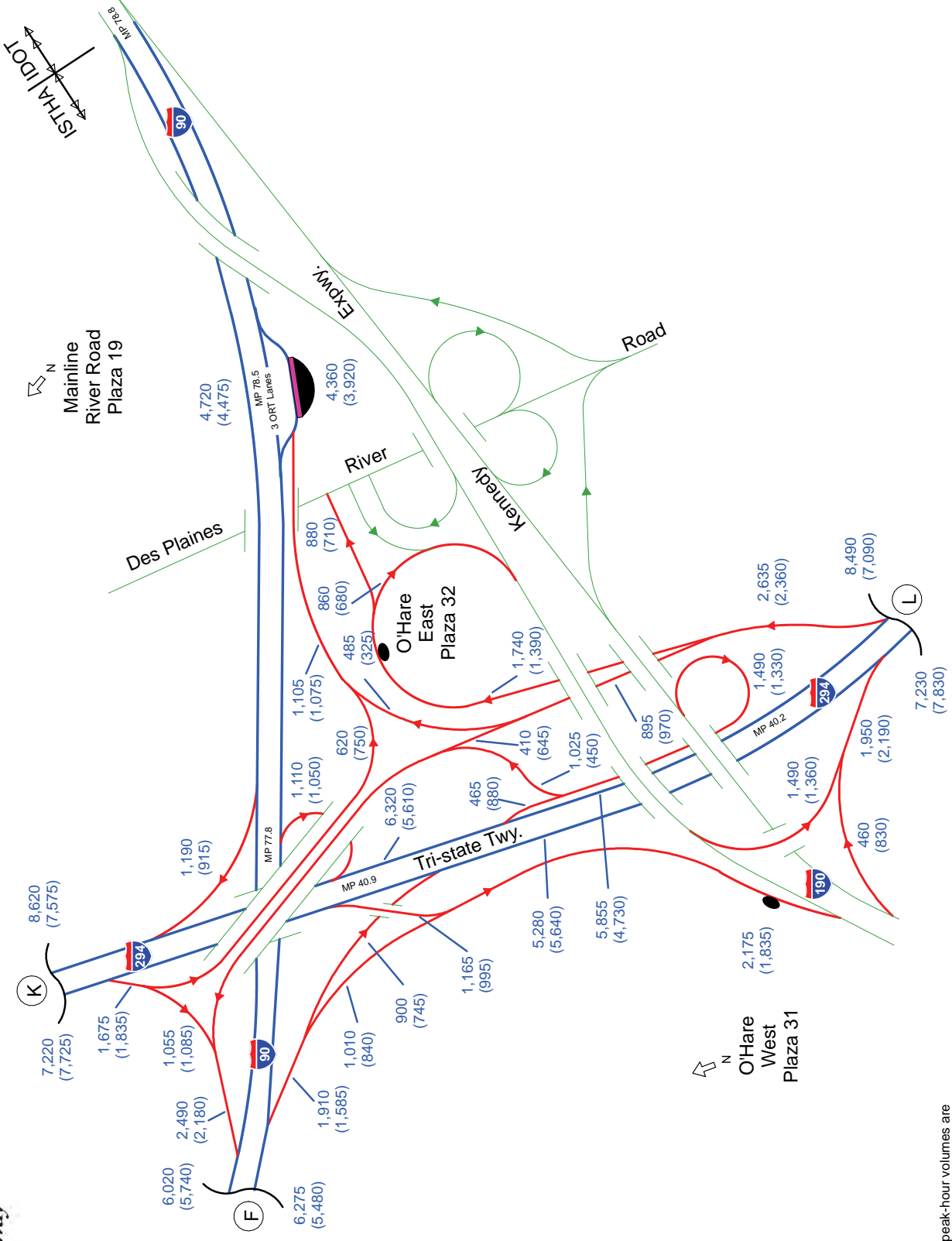

Note:
 The 2012 AM & PM peak-hour volumes are defined as the 85th Percentile volumes occurring in the 6:00 to 8:00 AM and the 4:00 to 6:00 PM periods respectively. Peak-hour volumes are calculated from Monday through Thursday hourly traffic volume data only, and exclude Holidays.

*** = A.M. Peak
 (*, ***) = P.M. Peak





2012 A.M. & P.M. Peak Hour Traffic

On Tri-State Tollway, from Russell Road to Lake Forest Oasis

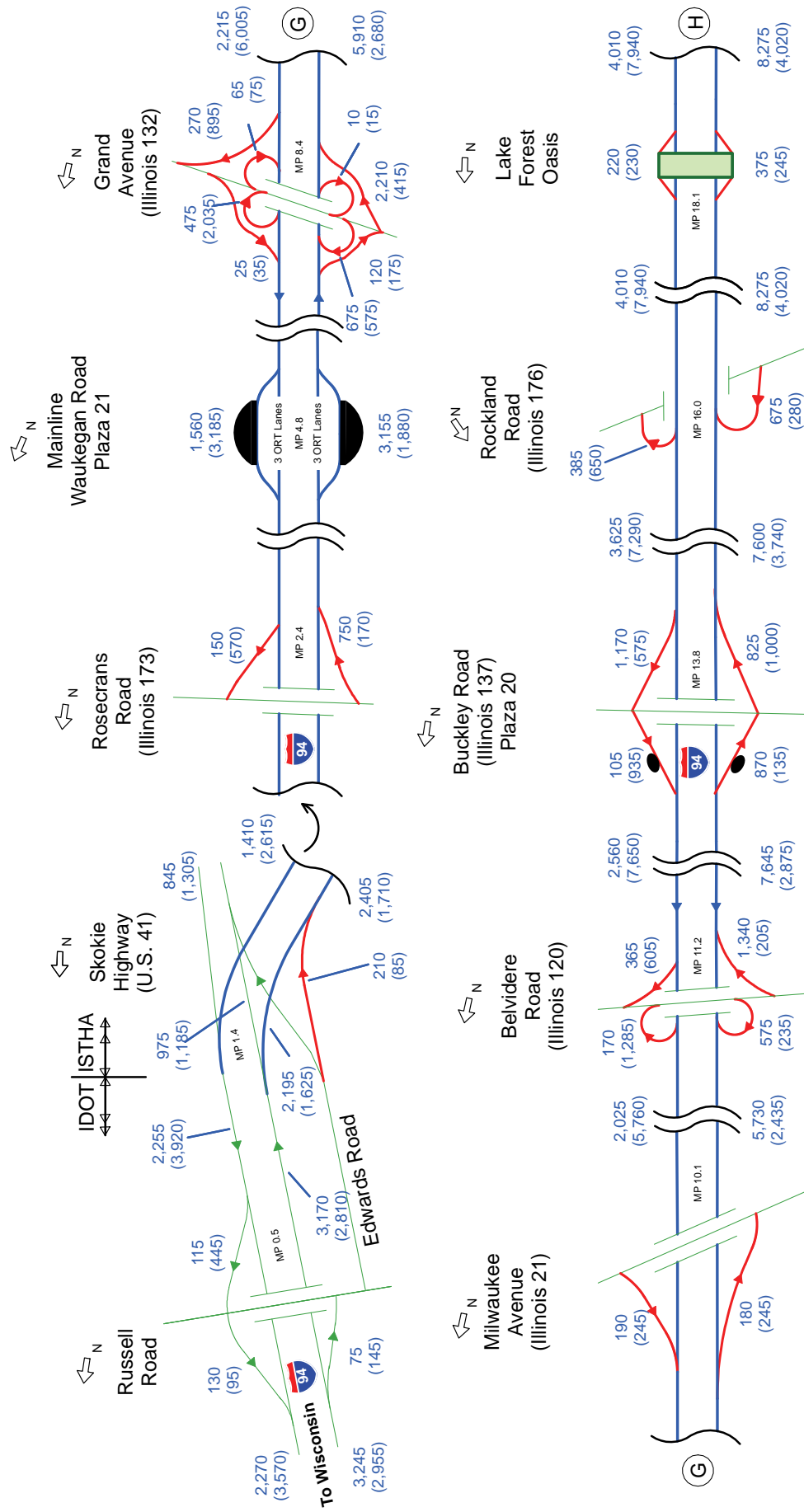

Note: The 2012 AM & PM peak-hour volumes are defined as the 85th Percentile volumes occurring in the 6:00 to 8:00 AM and the 4:00 to 6:00 PM periods respectively. Peak-hour volumes are calculated from Monday through Thursday hourly traffic volume data only, and exclude Holidays.

* ** = A.M. Peak
 (*, **) = P.M. Peak





2012 A.M. & P.M. Peak Hour Traffic

On Tri-State Tollway, from Town Line Road (Illinois 60) to Golf Road (Illinois 58) and Edens Spur

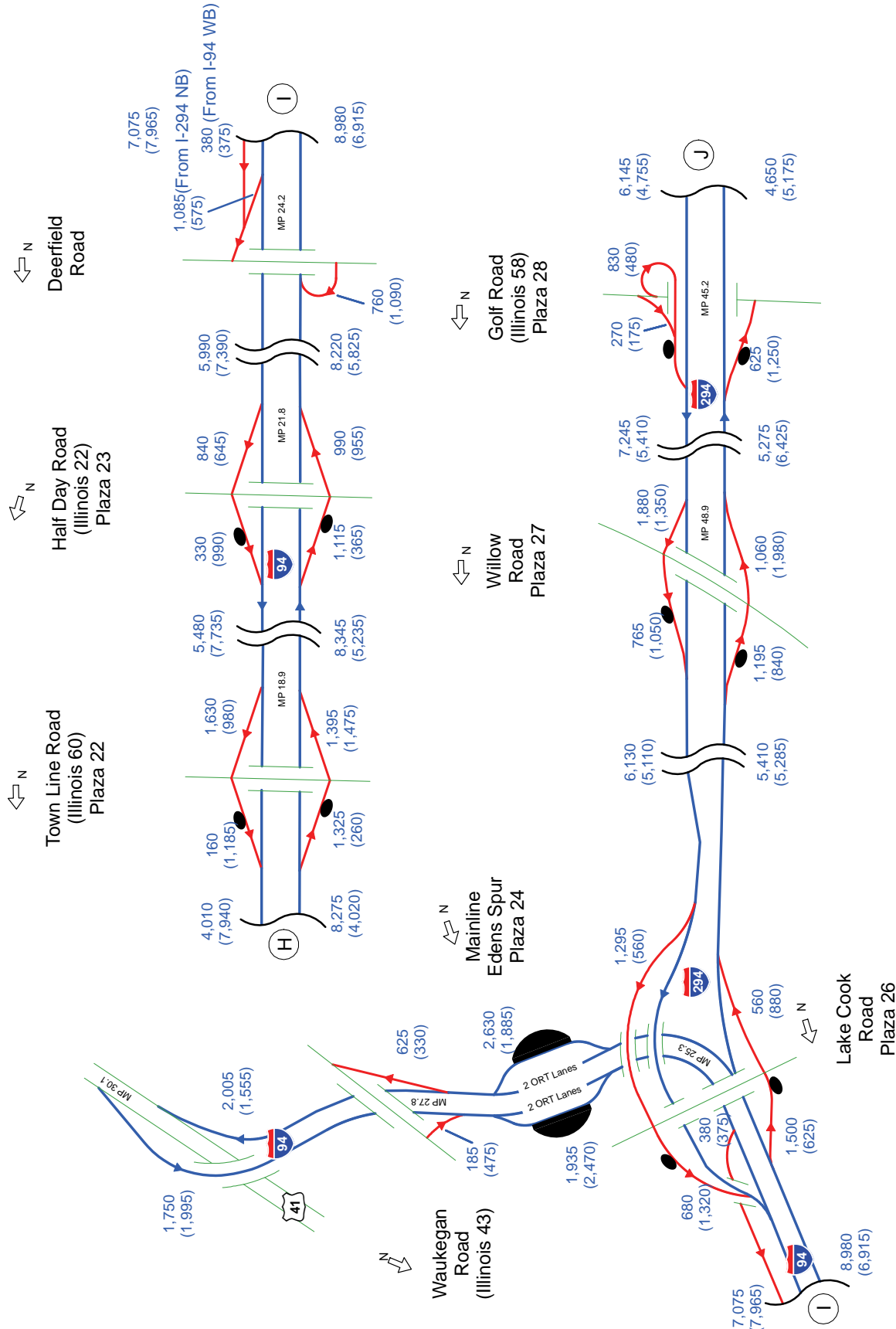

Note:
 The 2012 AM & PM peak-hour volumes are defined as the 85th Percentile volumes occurring in the 6:00 to 8:00 AM and the 4:00 to 6:00 PM periods respectively. Peak-hour volumes are calculated from Monday through Thursday hourly traffic volume data only, and exclude Holidays.

*** = A.M. Peak
 (*, ***) = P.M. Peak





2012 A.M. & P.M. Peak Hour Traffic

On Tri-State Tollway, from Dempster Street to O'Hare Oasis

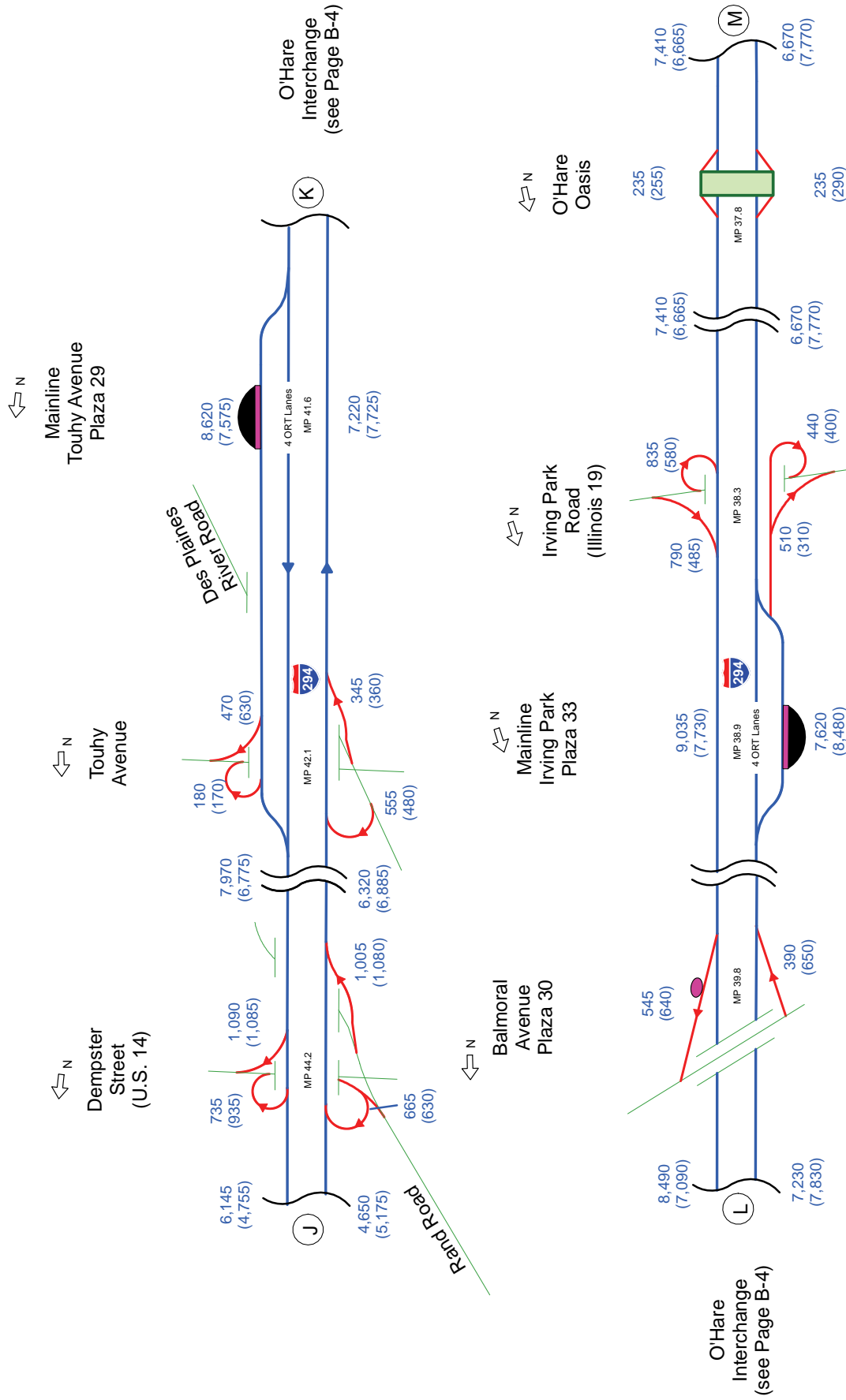

Note:
 The 2012 AM & PM peak-hour volumes are defined as the 85th Percentile volumes occurring in the 6:00 to 8:00 AM and the 4:00 to 6:00 PM periods respectively. Peak-hour volumes are calculated from Monday through Thursday hourly traffic volume data only, and exclude Holidays.

* * * * * = A.M. Peak
 (*, ***) = P.M. Peak





2012 A.M. & P.M. Peak Hour Traffic

On Tri-State Tollway, from North Avenue / Lake Street to Reagan Memorial Tollway I-88

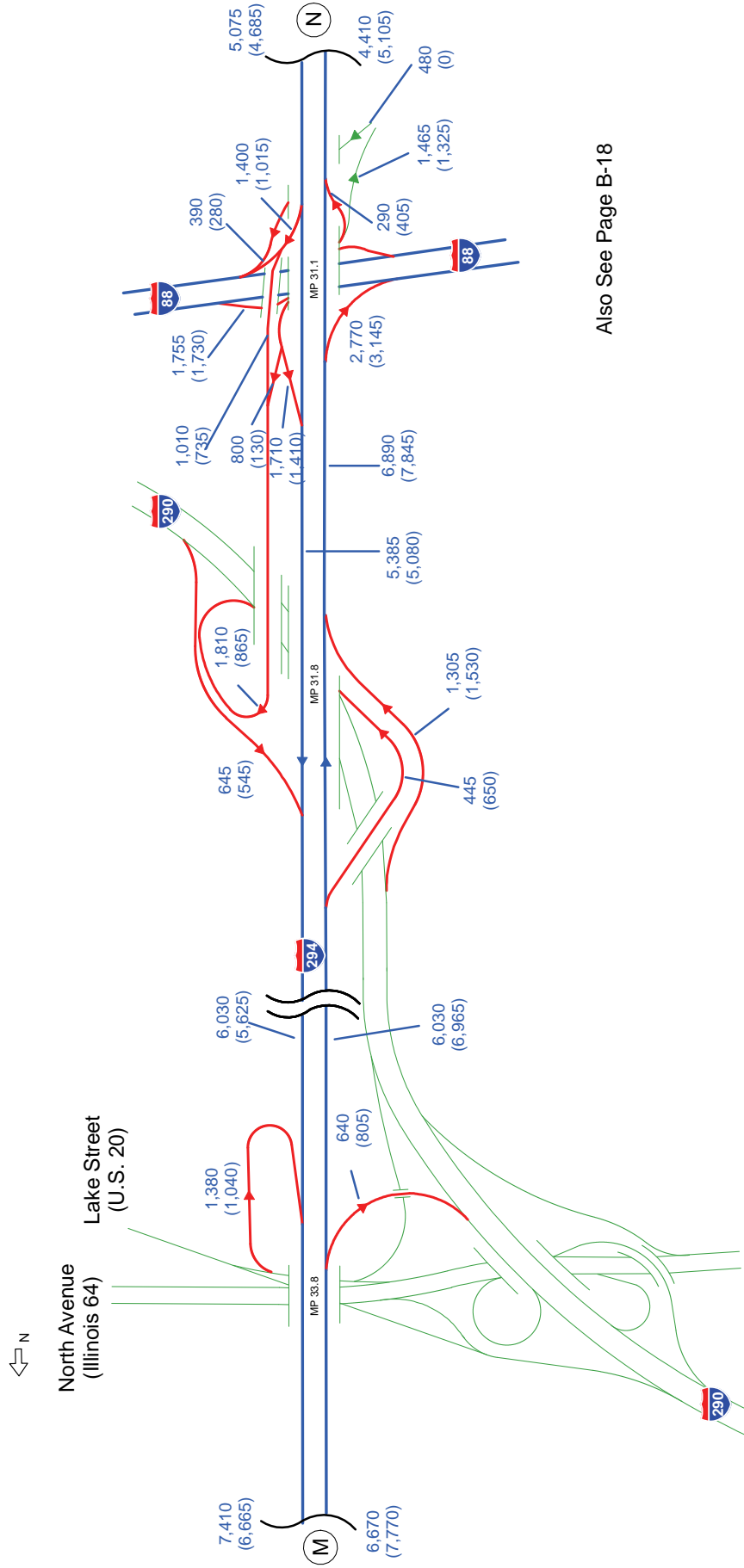

Also See Page B-18

Note:
 The 2012 AM & PM peak-hour volumes are defined as the 85th Percentile volumes occurring in the 6:00 to 8:00 AM and the 4:00 to 6:00 PM periods respectively. Peak-hour volumes are calculated from Monday through Thursday hourly traffic volume data only, and exclude Holidays.

*** = A.M. Peak
 (*, ***) = P.M. Peak





2012 A.M. & P.M. Peak Hour Traffic

On Tri-State Tollway, from Roosevelt Road to Hinsdale Oasis

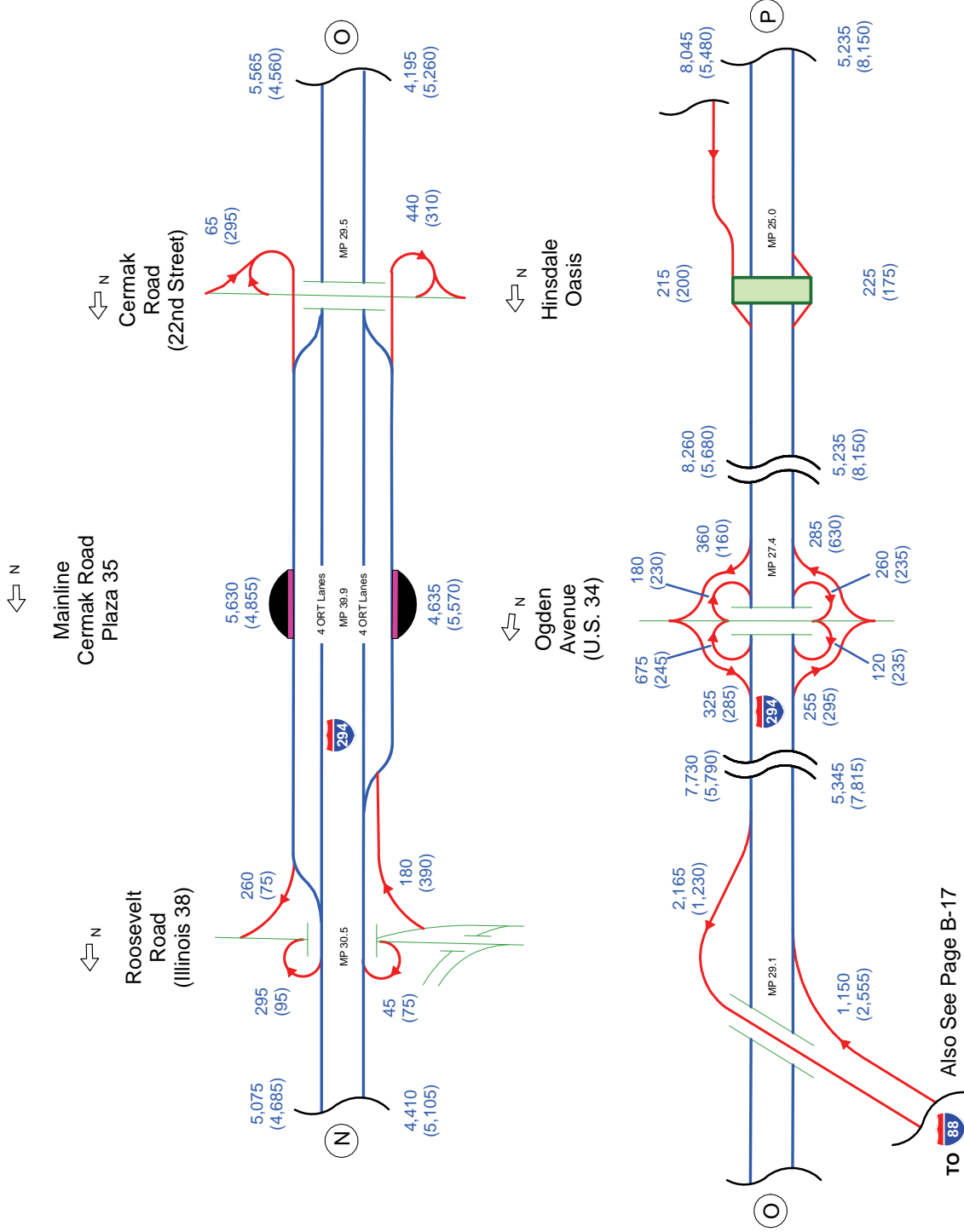

TO Also See Page B-17

Note:
 The 2012 AM & PM peak-hour volumes are defined as the 85th Percentile volumes occurring in the 6:00 to 8:00 AM and the 4:00 to 6:00 PM periods respectively. Peak-hour volumes are calculated from Monday through Thursday hourly traffic volume data only, and exclude Holidays.

* *** = A.M. Peak
 (*, ***) = P.M. Peak





2012 A.M. & P.M. Peak Hour Traffic

On Tri-State Tollway, from Joliet Road (Plaza 37) to Willow Springs Road (Plaza 34)

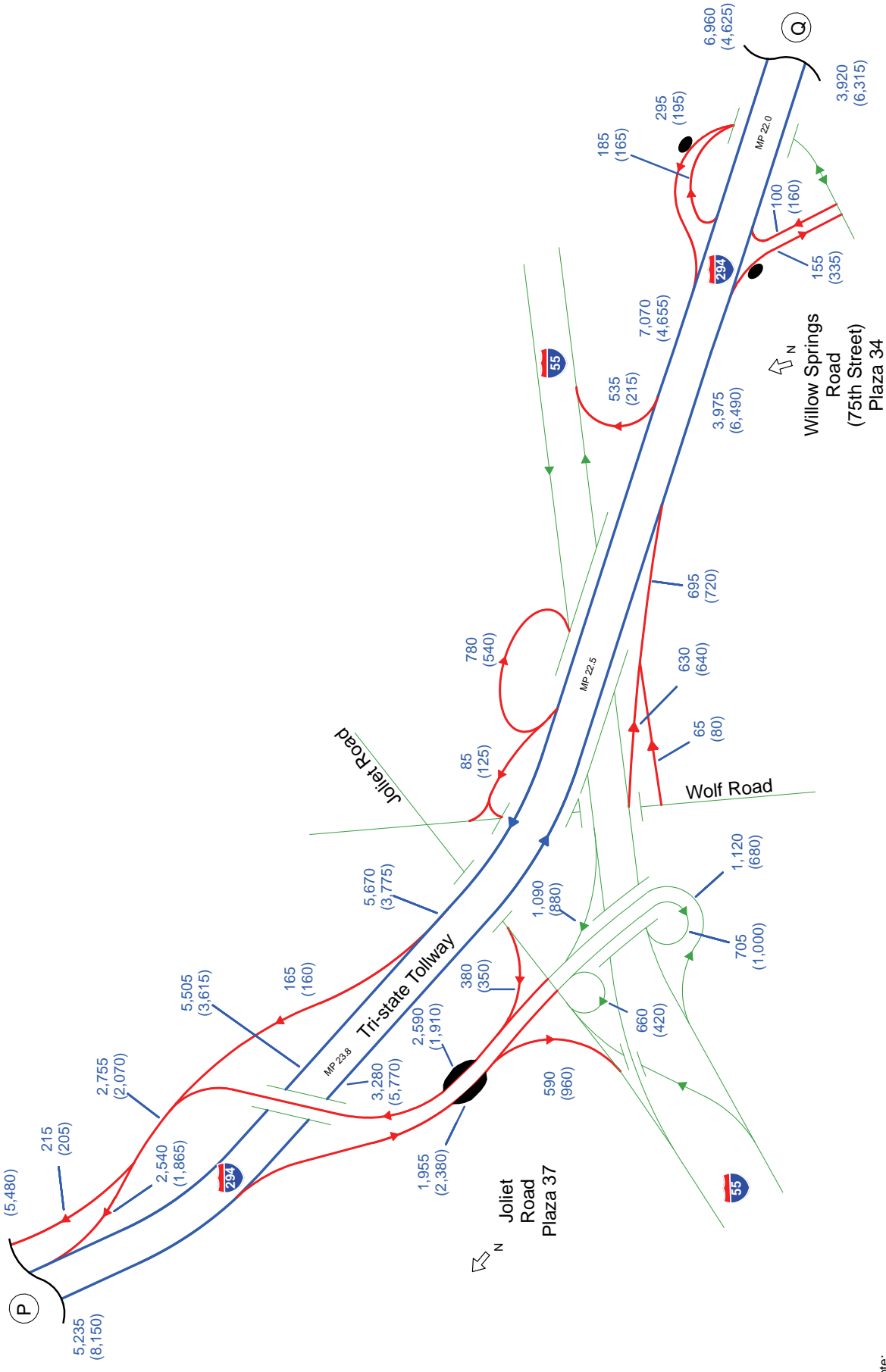

Note:
 The 2012 AM & PM peak-hour volumes are defined as the 85th Percentile volumes occurring in the 6:00 to 8:00 AM and the 4:00 to 6:00 PM periods respectively. Peak-hour volumes are calculated from Monday through Thursday hourly traffic volume data only, and exclude Holidays.

* ** = A.M. Peak
 (*, **) = P.M. Peak





2012 A.M. & P.M. Peak Hour Traffic

On Tri-State Tollway, from Archer / Lagrange / 79th Street to 163rd Street (Plaza 41)

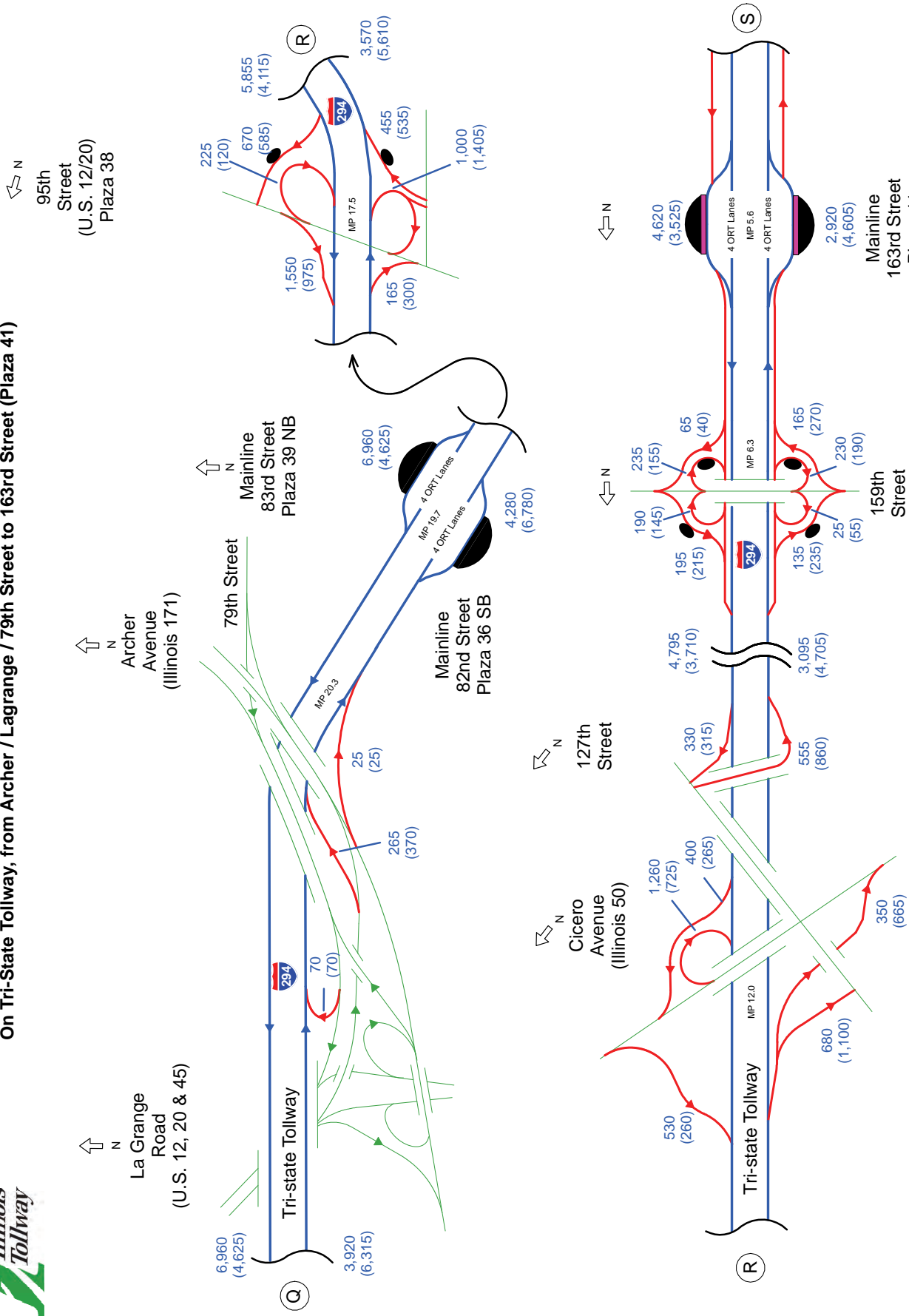

Note: The 2012 AM & PM peak-hour volumes are defined as the 85th Percentile volumes occurring in the 6:00 to 8:00 AM and the 4:00 to 6:00 PM periods respectively. Peak-hour volumes are calculated from Monday through Thursday hourly traffic volume data only, and exclude Holidays.

* ** = A.M. Peak
 (*, **) = P.M. Peak





2012 A.M. & P.M. Peak Hour Traffic

On Tri-State Tollway, from Interstate 80 to Bishop Ford / Kingery Expressway

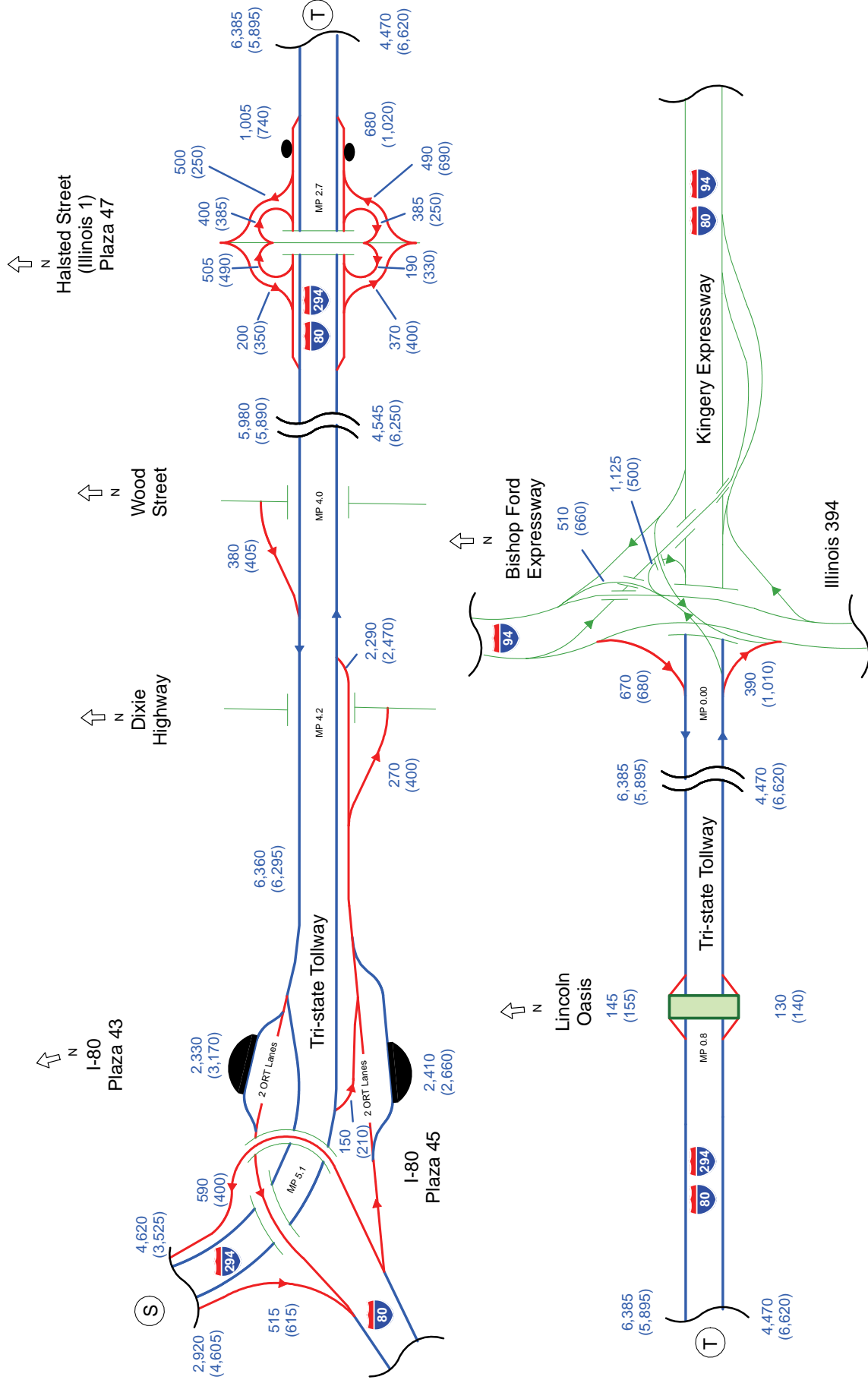

Note:
 The 2012 AM & PM peak-hour volumes are defined as the 85th Percentile volumes occurring in the 6:00 to 8:00 AM and the 4:00 to 6:00 PM periods respectively. Peak-hour volumes are calculated from Monday through Thursday hourly traffic volume data only, and exclude Holidays.

**** = A.M. Peak
 (*, ***) = P.M. Peak

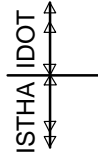



2012 A.M. & P.M. Peak Hour Traffic

On Reagan Memorial Tollway, from Illinois 26 to Orchard Road

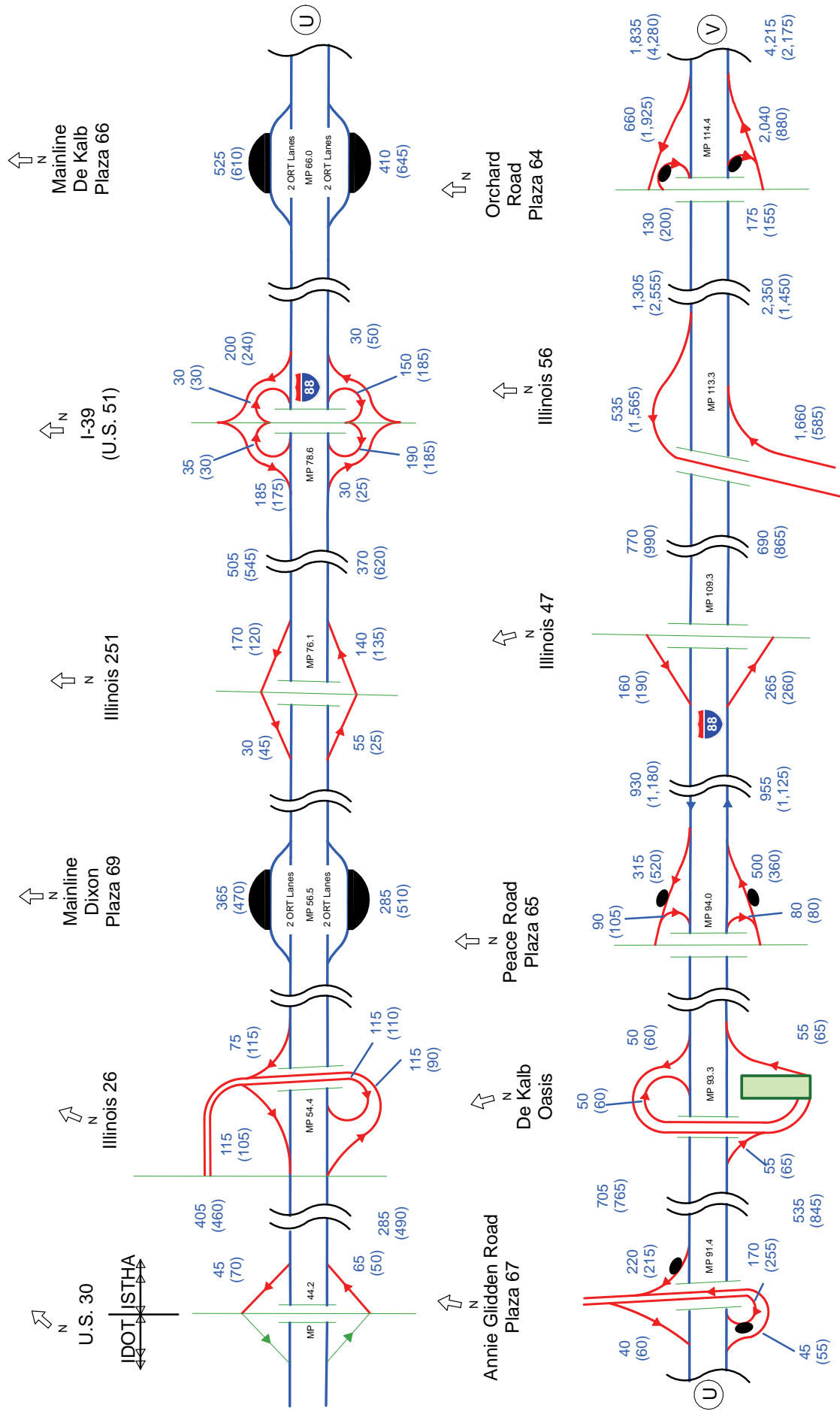

Note: The 2012 AM & PM peak-hour volumes are defined as the 85th Percentile volumes occurring in the 6:00 to 8:00 AM and the 4:00 to 6:00 PM periods respectively. Peak-hour volumes are calculated from Monday through Thursday hourly traffic volume data only, and exclude Holidays.

*** = A.M. Peak
 (*, ***) = P.M. Peak





2012 A.M. & P.M. Peak Hour Traffic

On Reagan Memorial Tollway, from Illinois 31 to Illinois 53

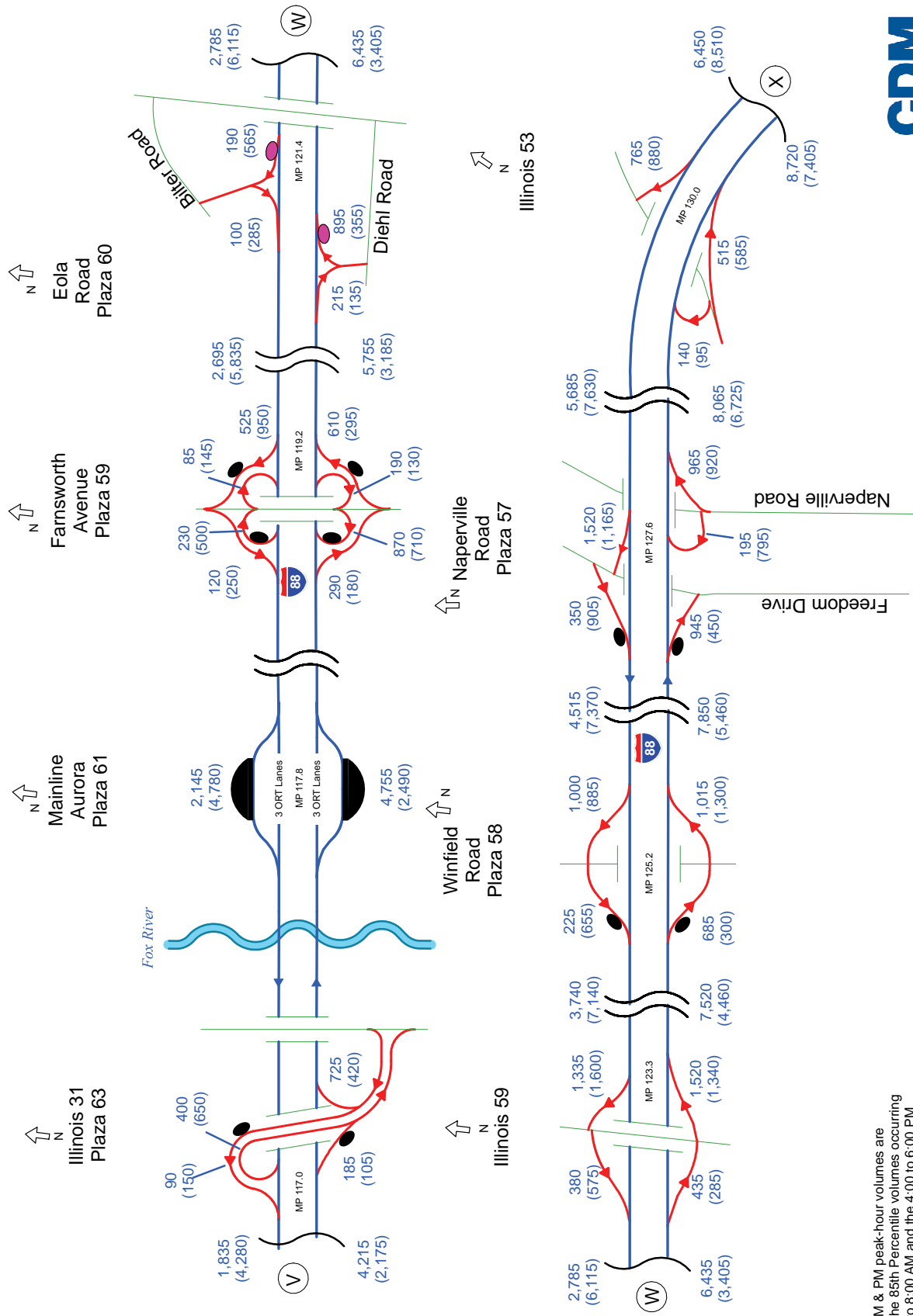

Note: The 2012 AM & PM peak-hour volumes are defined as the 85th Percentile volumes occurring in the 6:00 to 8:00 AM and the 4:00 to 6:00 PM periods respectively. Peak-hour volumes are calculated from Monday through Thursday hourly traffic volume data only, and exclude Holidays.

*** = A.M. Peak
 (*, ***) = P.M. Peak





2012 A.M. & P.M. Peak Hour Traffic

On Reagan Memorial Tollway, Veterans Memorial Tollway West Interchange

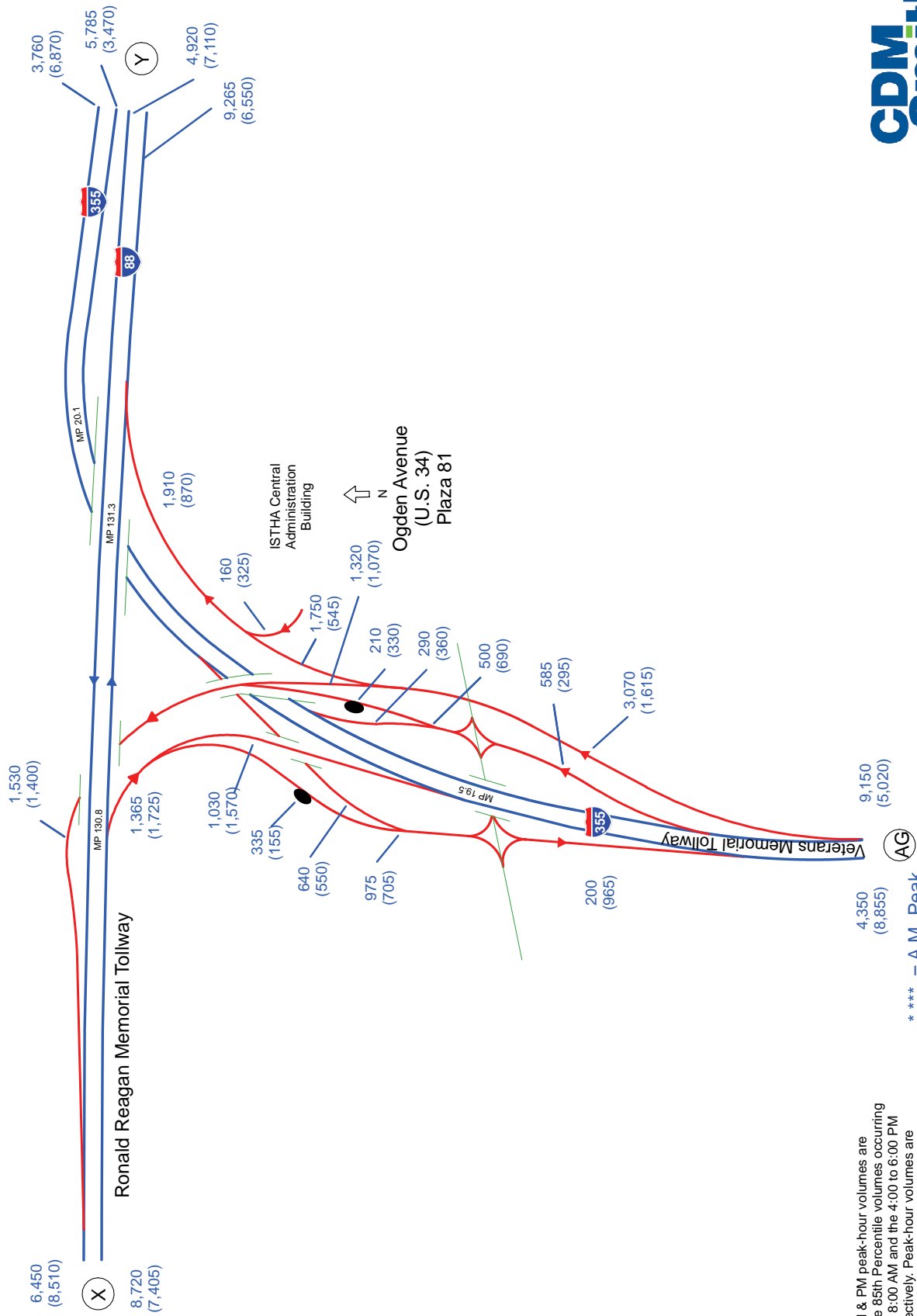

Note:
 The 2012 AM & PM peak-hour volumes are defined as the 85th Percentile volumes occurring in the 6:00 to 8:00 AM and the 4:00 to 6:00 PM periods respectively. Peak-hour volumes are calculated from Monday through Thursday hourly traffic volume data only, and exclude Holidays.

*** = A.M. Peak
 (*, ***) = P.M. Peak





2012 A.M. & P.M. Peak Hour Traffic

On Reagan Memorial Tollway, Veterans Memorial Tollway East Interchange

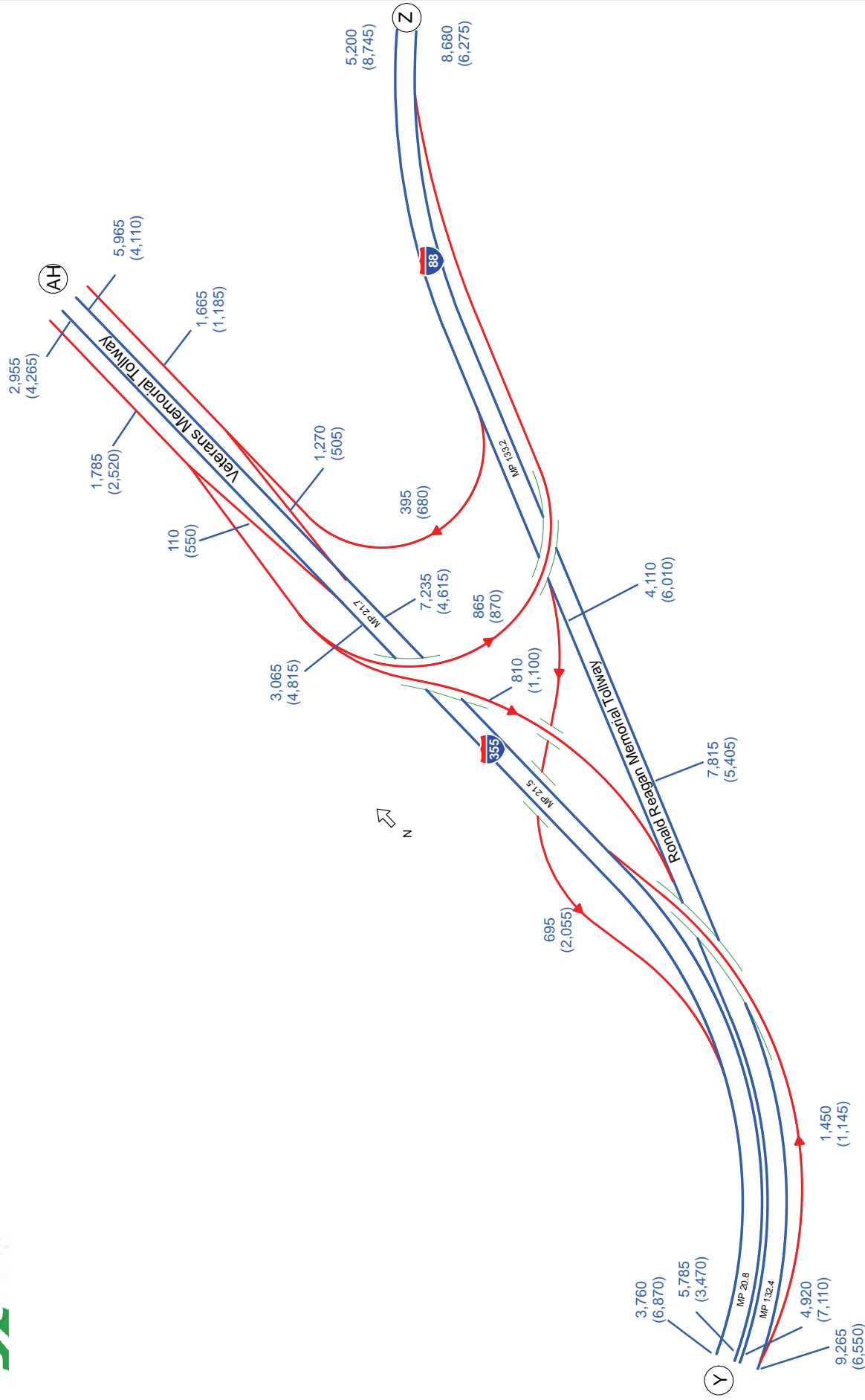

Note:
 The 2012 AM & PM peak-hour volumes are defined as the 85th Percentile volumes occurring in the 6:00 to 8:00 AM and the 4:00 to 6:00 PM periods respectively. Peak-hour volumes are calculated from Monday through Thursday hourly traffic volume data only, and exclude Holidays.

*** = A.M. Peak
 (*, ***) = P.M. Peak





2012 A.M. & P.M. Peak Hour Traffic

On Reagan Memorial Tollway, from Highland Avenue to Harger Road

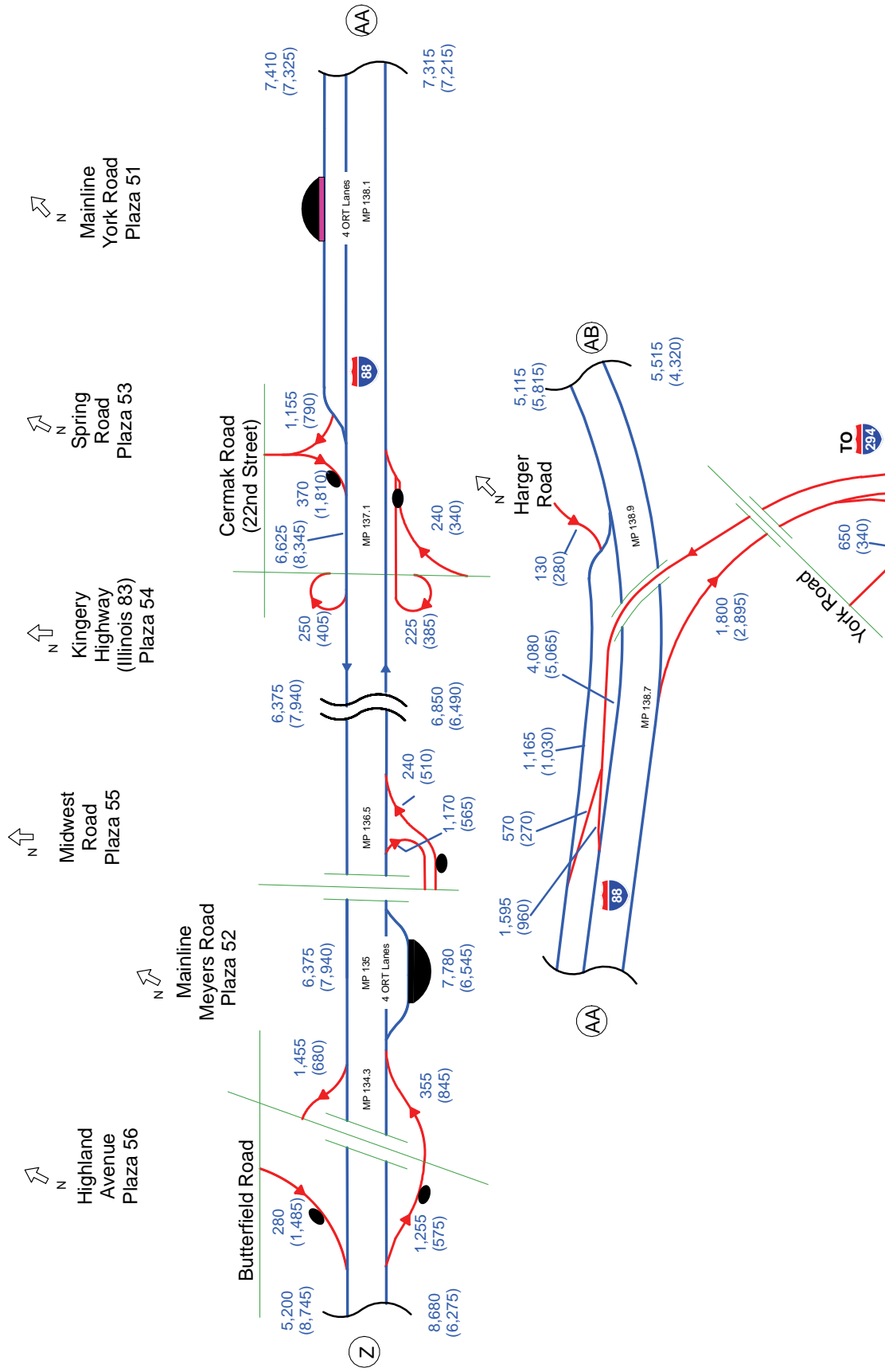

Note:
 The 2012 AM & PM peak-hour volumes are defined as the 85th Percentile volumes occurring in the 6:00 to 8:00 AM and the 4:00 to 6:00 PM periods respectively. Peak-hour volumes are calculated from Monday through Thursday hourly traffic volume data only, and exclude Holidays.

*** = A.M. Peak
 (*, ***) = P.M. Peak

Also See Page B-9





2012 A.M. & P.M. Peak Hour Traffic

On Reagan Memorial Tollway, from Roosevelt Road to Eisenhower Expressway, I-290

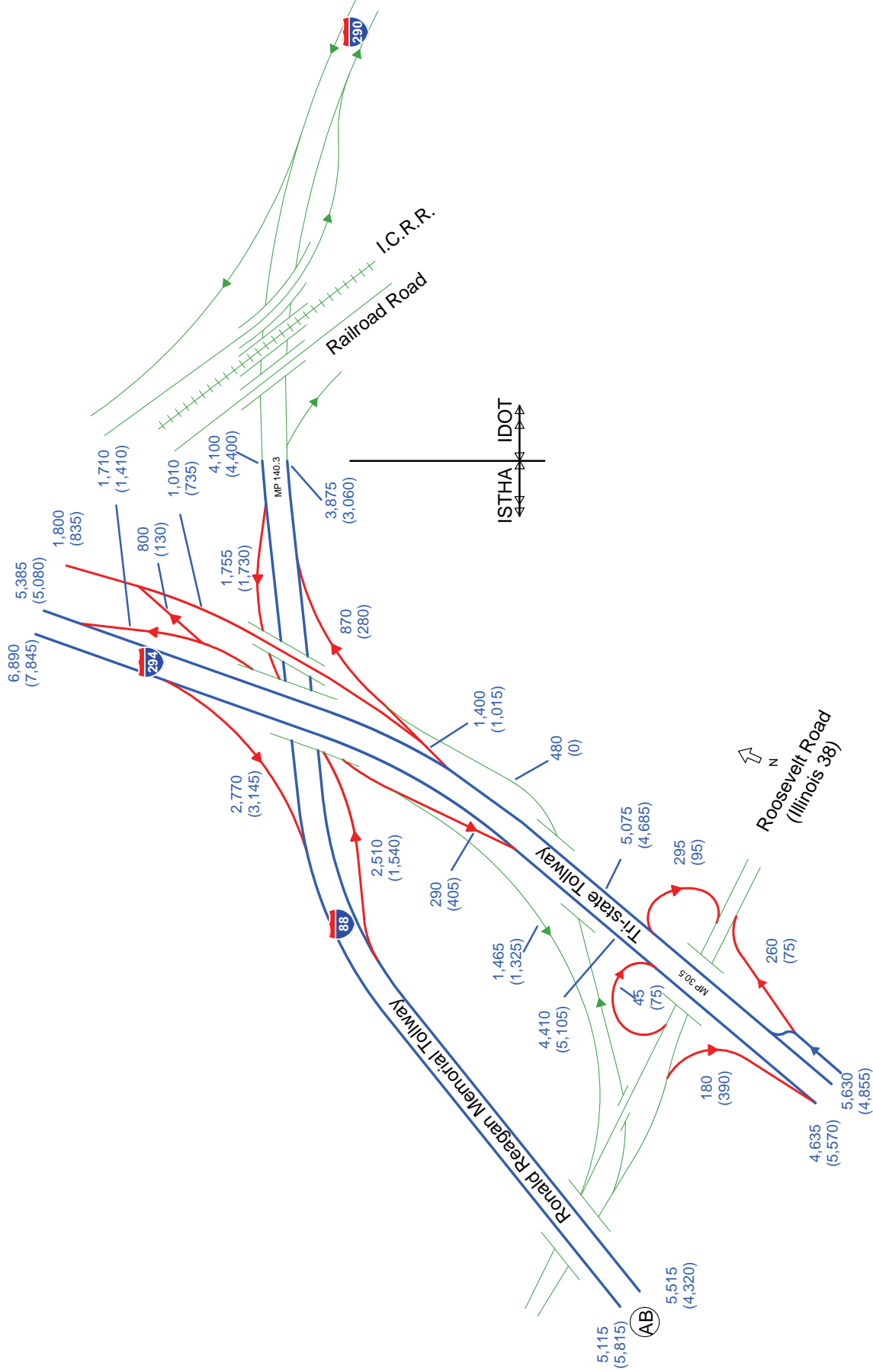

Note:
 The 2012 AM & PM peak-hour volumes are defined as the 85th Percentile volumes occurring in the 6:00 to 8:00 AM and the 4:00 to 6:00 PM periods respectively. Peak-hour volumes are calculated from Monday through Thursday hourly traffic volume data only, and exclude Holidays.

**** = A.M. Peak
 (*, ***) = P.M. Peak





2012 A.M. & P.M. Peak Hour Traffic

On Veterans Memorial Tollway, from Interstate 80 to 127th Street

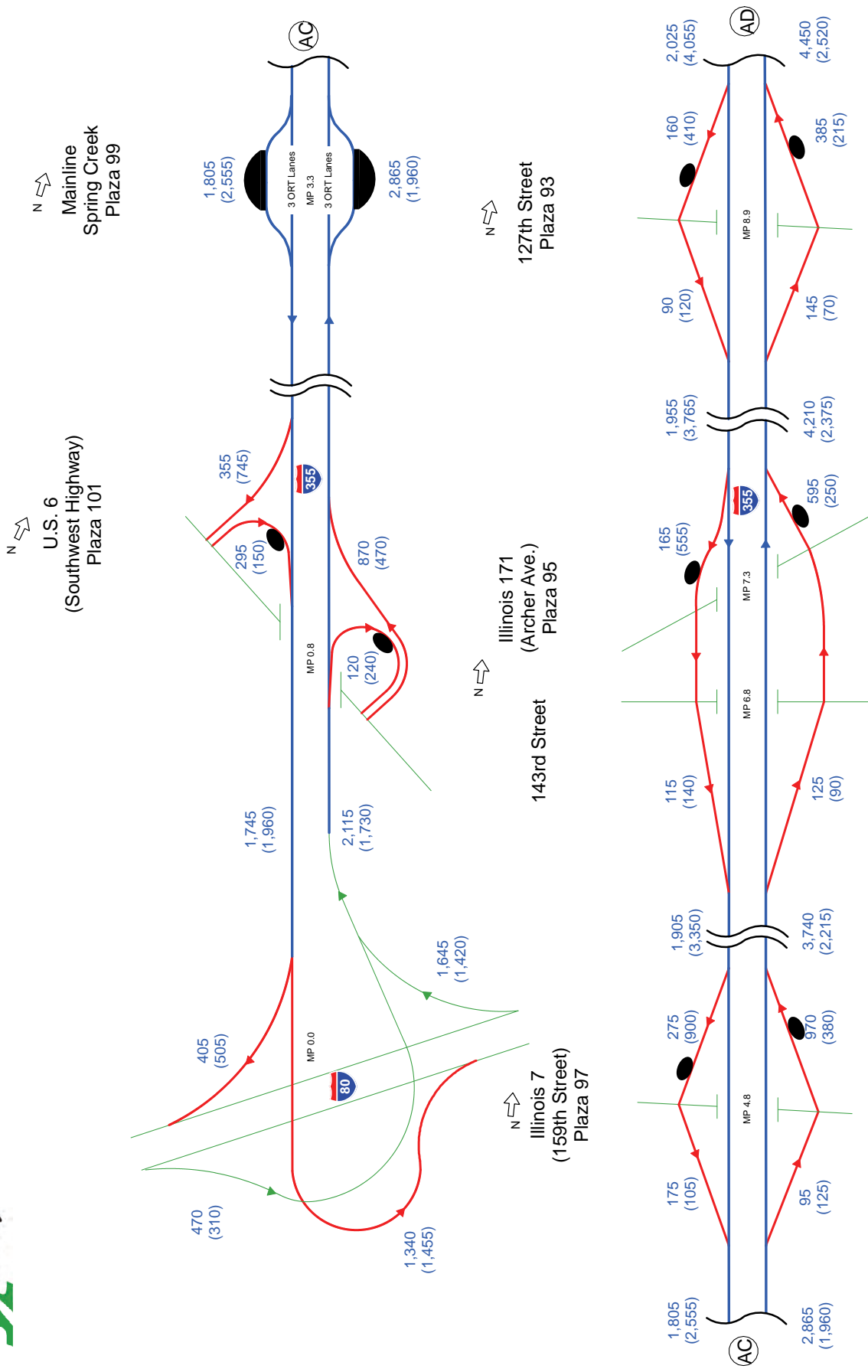

Note:
 The 2012 AM & PM peak-hour volumes are defined as the 85th Percentile volumes occurring in the 6:00 to 8:00 AM and the 4:00 to 6:00 PM periods respectively. Peak-hour volumes are calculated from Monday through Thursday hourly traffic volume data only, and exclude Holidays.

*** = A.M. Peak
 (*, ***) = P.M. Peak





2012 A.M. & P.M. Peak Hour Traffic

On Veterans Memorial Tollway, At Interstate 55

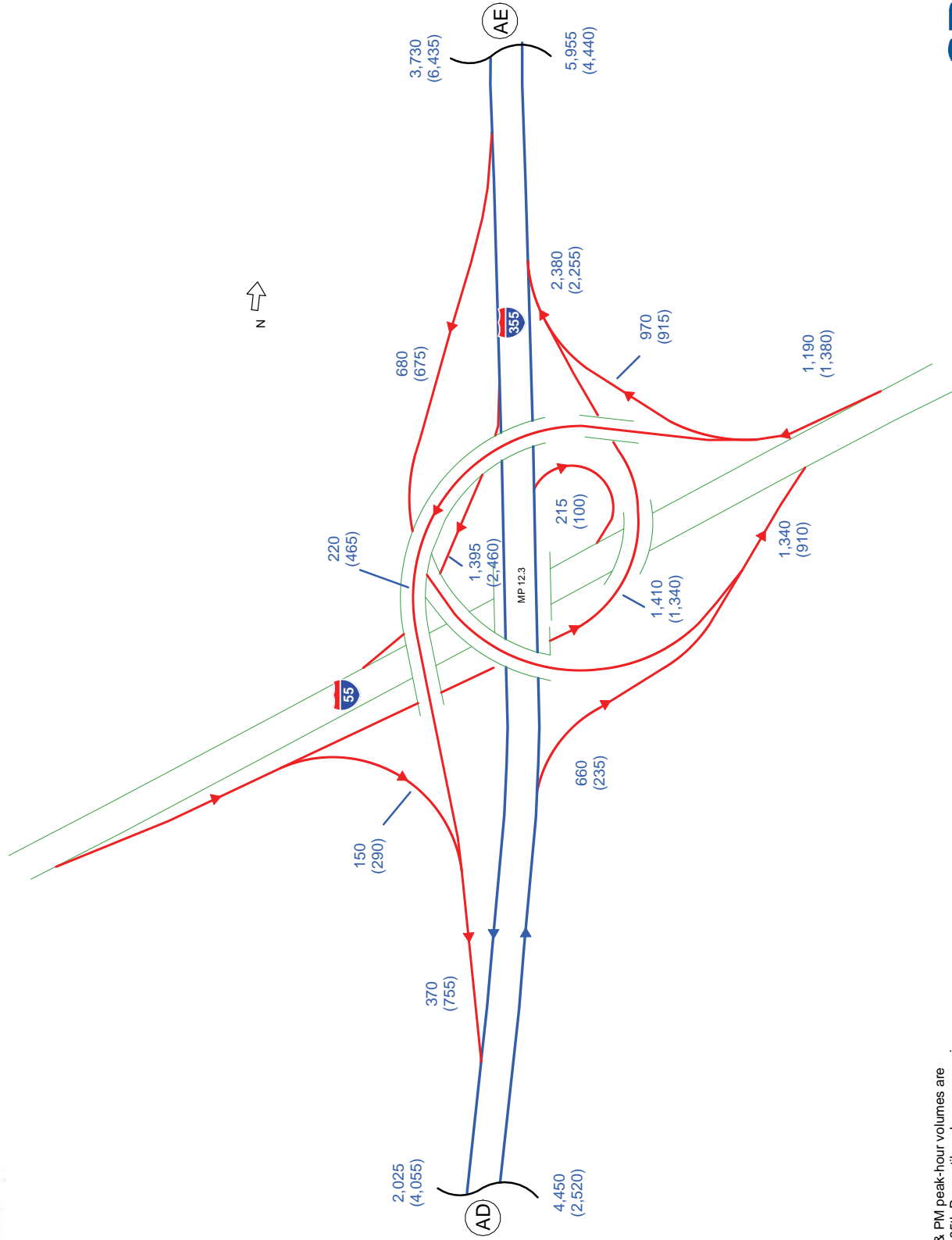

Note:
 The 2012 AM & PM peak-hour volumes are defined as the 85th Percentile volumes occurring in the 6:00 to 8:00 AM and the 4:00 to 6:00 PM periods respectively. Peak-hour volumes are calculated from Monday through Thursday hourly traffic volume data only, and exclude Holidays.

* ** = A.M. Peak
 (*, **) = P.M. Peak





2012 A.M. & P.M. Peak Hour Traffic

On Veterans Memorial Tollway, from Boughton Road to Maple Avenue

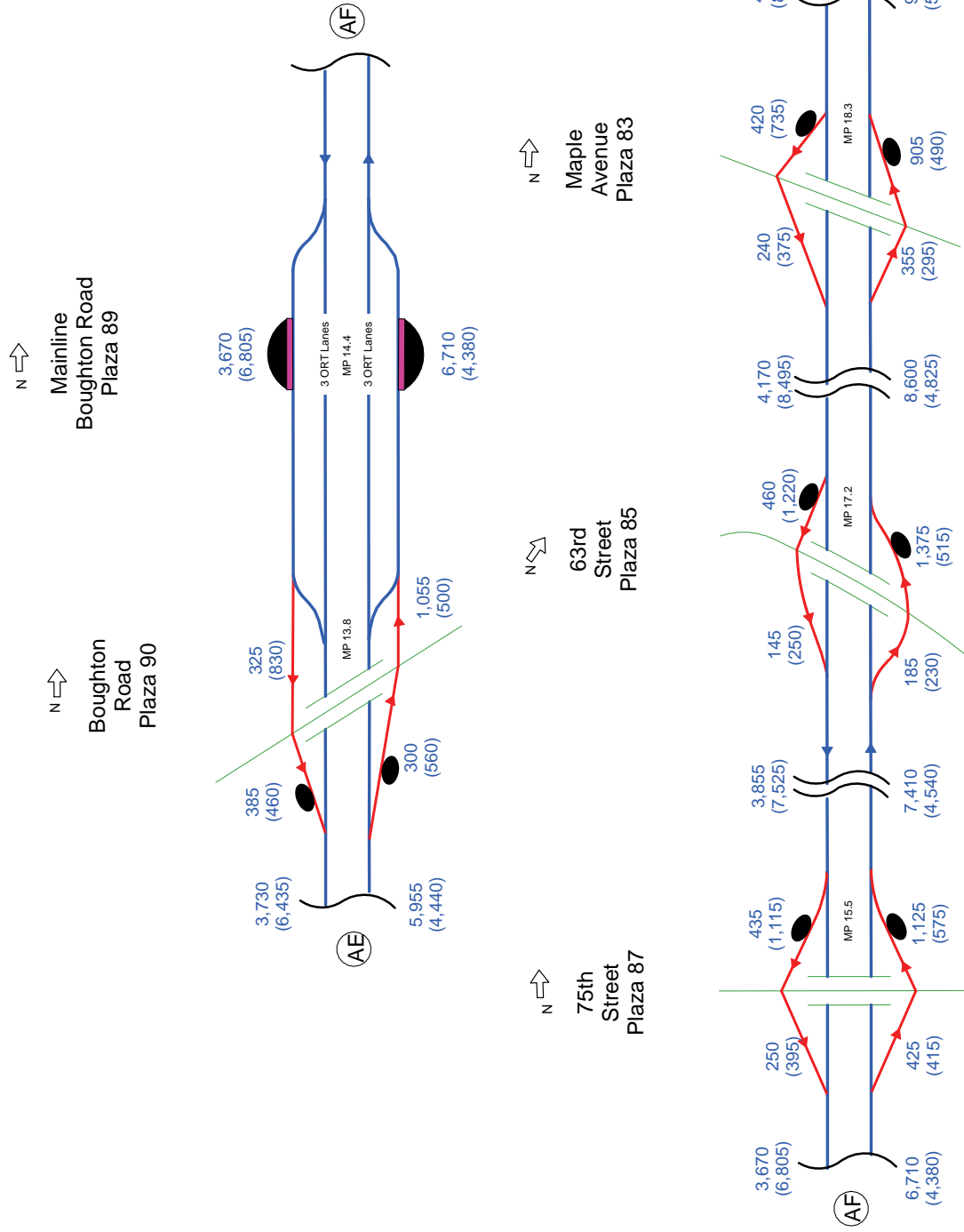

Note:
 The 2012 AM & PM peak-hour volumes are defined as the 85th Percentile volumes occurring in the 6:00 to 8:00 AM and the 4:00 to 6:00 PM periods respectively. Peak-hour volumes are calculated from Monday through Thursday hourly traffic volume data only, and exclude Holidays.

*** = A.M. Peak
 (*, ***) = P.M. Peak





2012 A.M. & P.M. Peak Hour Traffic On Veterans Memorial Tollway, from Ogden Avenue / West Interchange to Army Trail Road

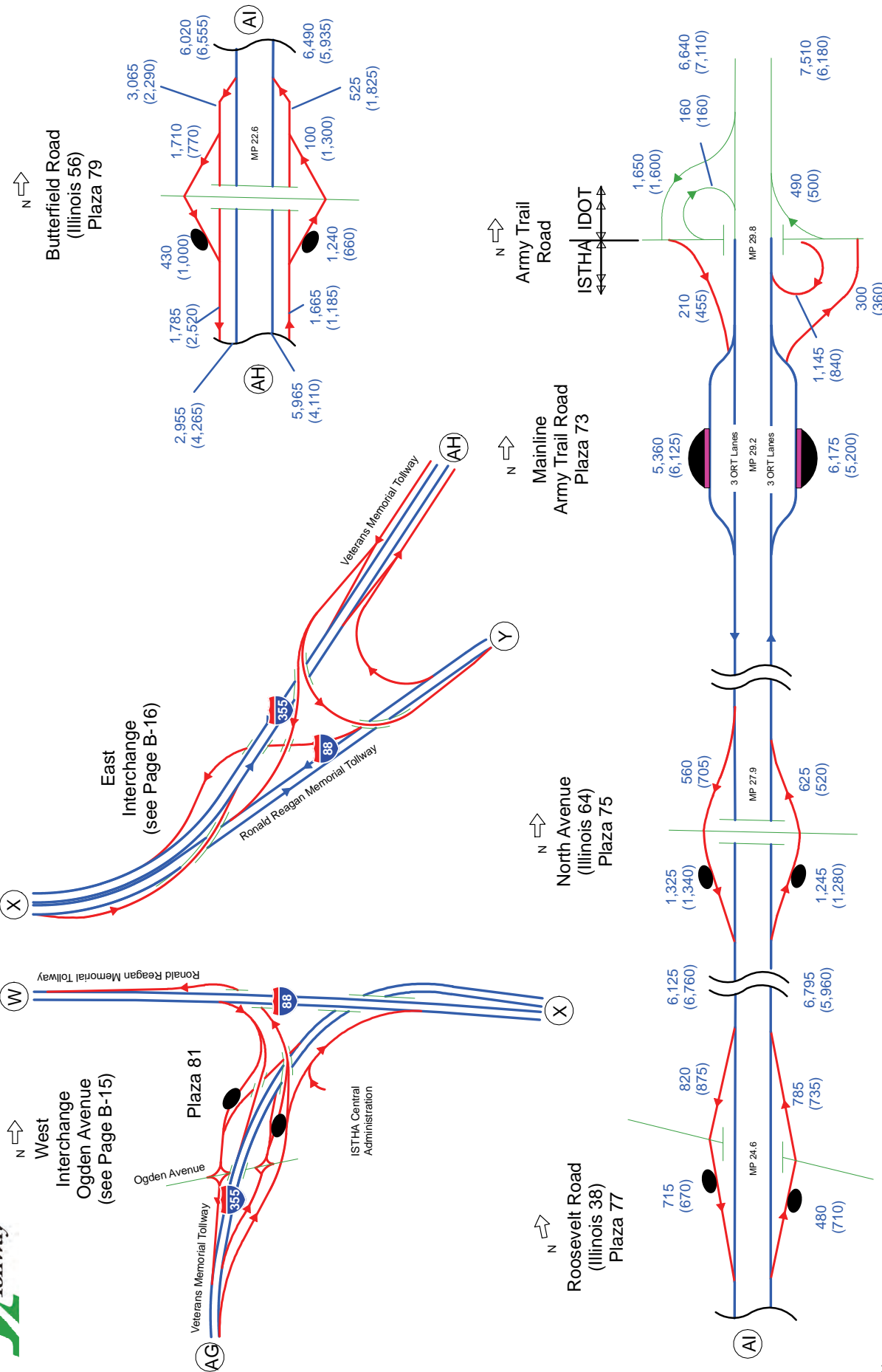

Note:
The 2012 AM & PM peak-hour volumes are defined as the 85th Percentile volumes occurring in the 6:00 to 8:00 AM and the 4:00 to 6:00 PM periods respectively. Peak-hour volumes are calculated from Monday through Thursday hourly traffic volume data only, and exclude Holidays.

* * * * * = A.M. Peak
(* , * * * *) = P.M. Peak



Appendix C Tab





2012 Construction Projects

Page#	Facility	Description	Milepost		Construction Schedule	
			Start	End	Start	End
ILLINOIS TOLLWAY						
C-2	I-90	Shoulder/Bridge Widening Sandwald Rd. to Kishwaukee River	45.0	47.5	04/2012	Ongoing (2014)
C-2	I-90	Interchange Construction IL 47 EB Exit and WB Entrance	46.5		06/2012	Ongoing (2013)
C-4	I-294	Tri-Level Bridge Reconstruction I-294 NB to I-90 WB Flyover Ramp	40.0	77.7	03/2012	06/2012
C-7 to C-11	I-294	Resurfacing 95th St. to Balmoral Ave.	17.5	39.8	04/2012	11/2012
C-11	I-294	Bridge Reconstruction 147th St.	8.3		05/2012	12/2012
C-13	I-88	Resurfacing IL 251 to IL 56	76.0	114.0	04/2012	12/2012
C-13	I-88	Reconstruction/Widening IL 56 to Orchard Rd.	114.2	114.5	06/2012	12/2012
IDOT EXPRESSWAY SYSTEM						
C-1	I-90/39	Reconstruction/Widening Rockton Rd. to Wisconsin State Line	0.0	2.5	04/2012	Ongoing (2013)
C-5	I-94	Interchange Reconstruction Russell Rd.	0.5		07/2012	Ongoing (2013)







2012 Lane Configuration

On Jane Addams Memorial Tollway, from Rockton Road to Genoa Road

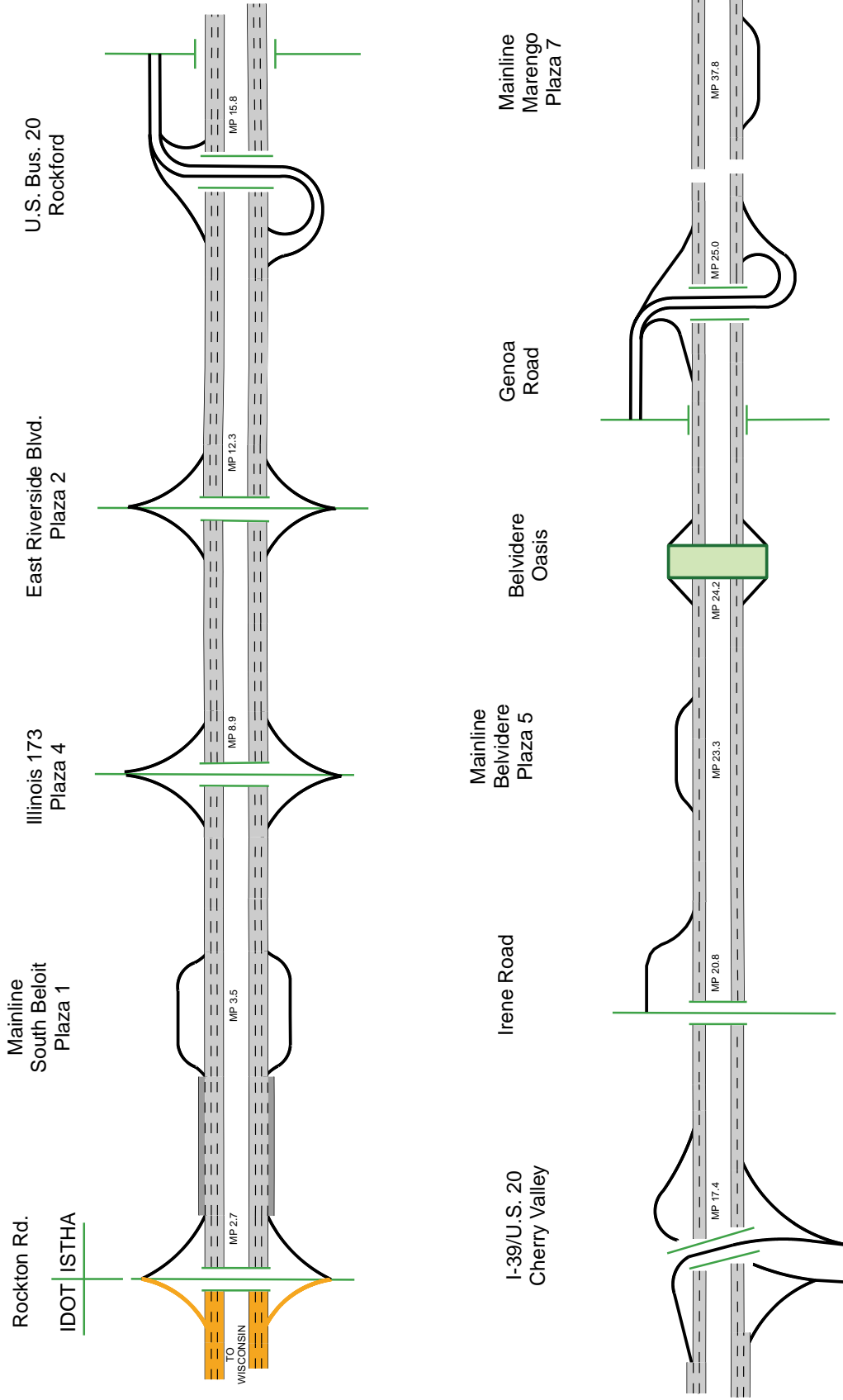

Resurfacing Projects Highlighted In **PURPLE**
Construction Projects Highlighted In **ORANGE**





2012 Lane Configuration

On Jane Addams Memorial Tollway, from U.S. 20, Marengo to Barrington Road

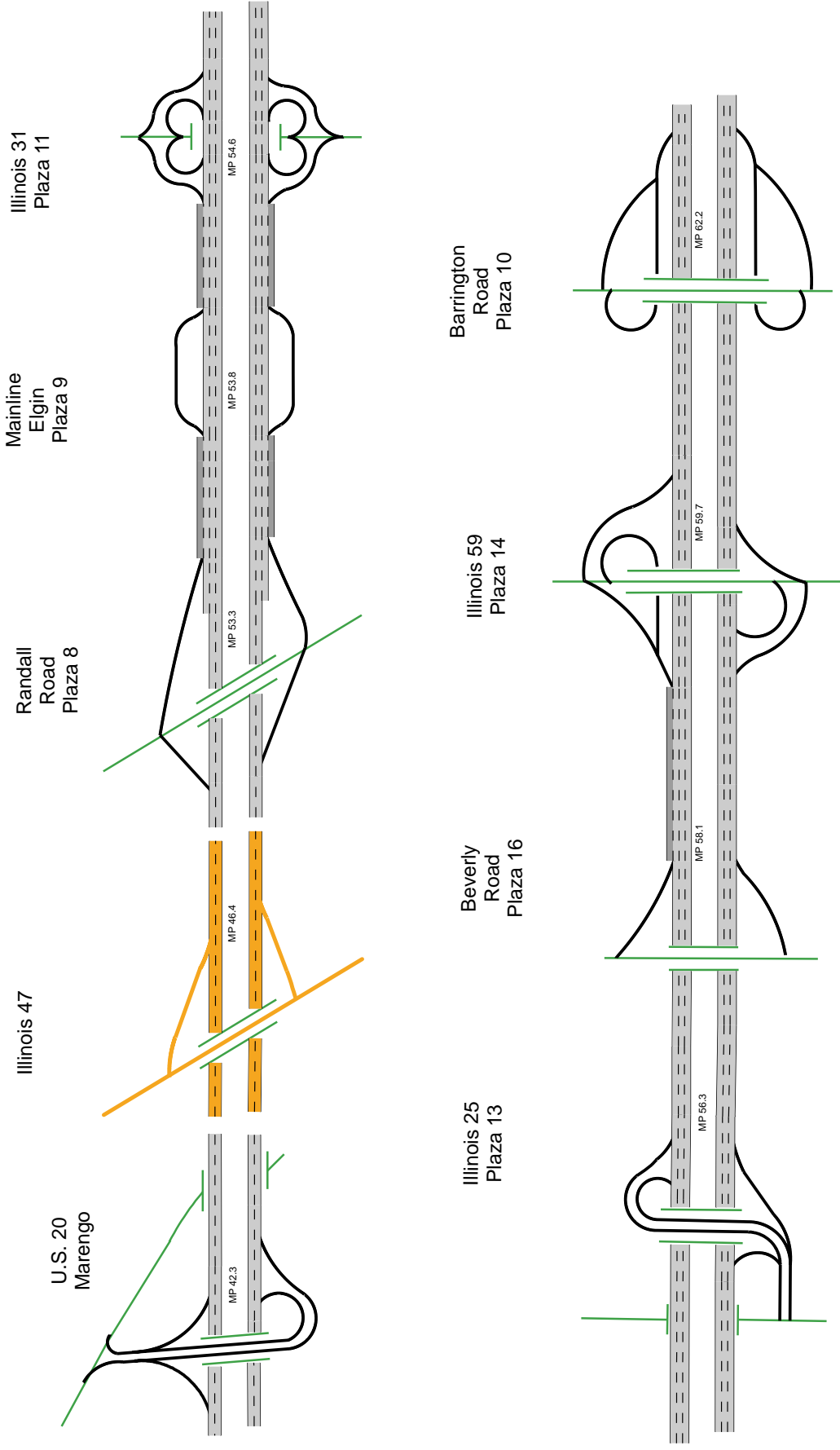

Resurfacing Projects Highlighted In **PURPLE**
Construction Projects Highlighted In **ORANGE**





2012 Lane Configuration

On Jane Addams Memorial Tollway, from Roselle Road to Devon Avenue

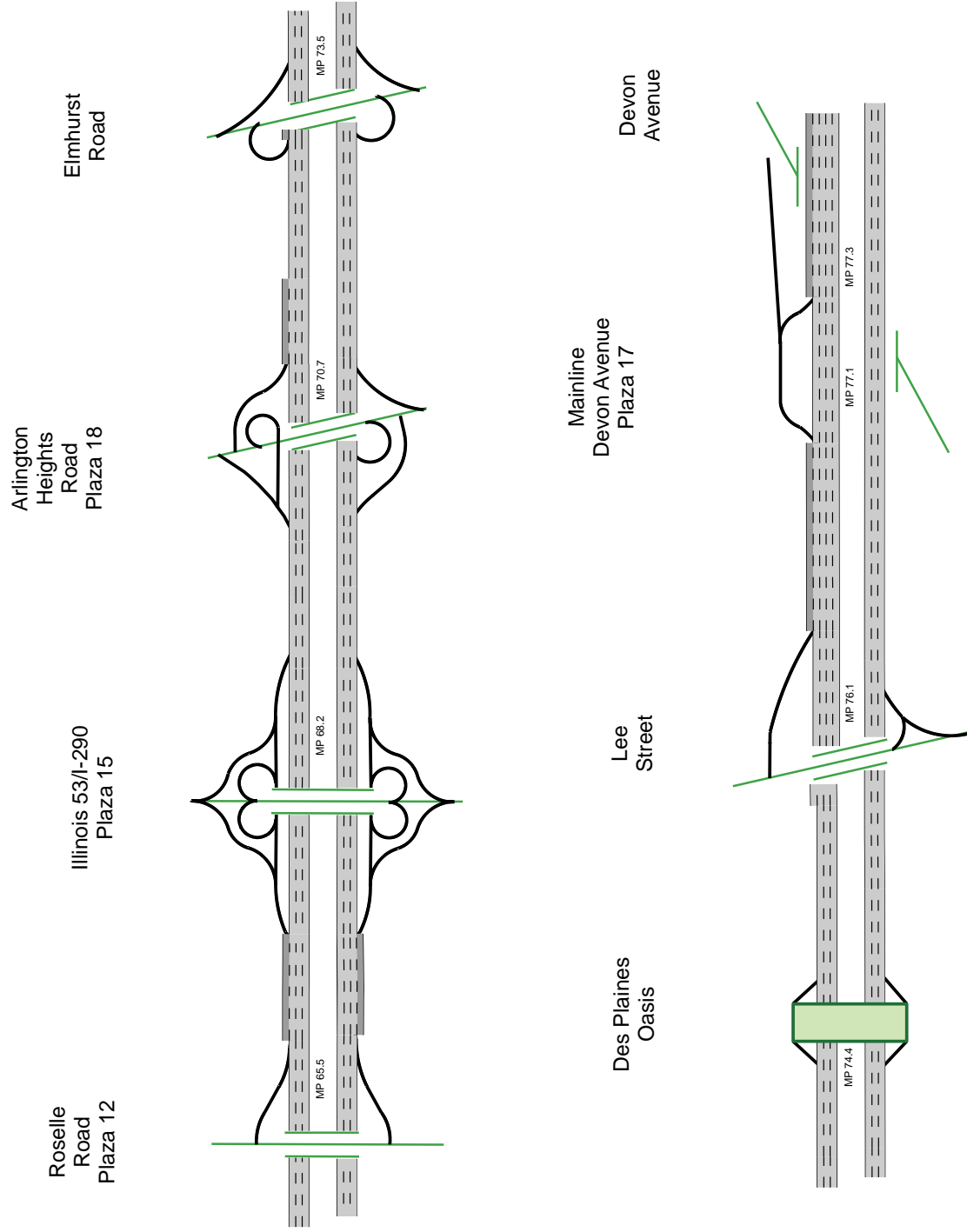

Resurfacing Projects Highlighted In **PURPLE**
Construction Projects Highlighted In **ORANGE**





2012 Lane Configuration

On Jane Addams Memorial Tollway, from Tri-State Tollway to Kennedy Expressway

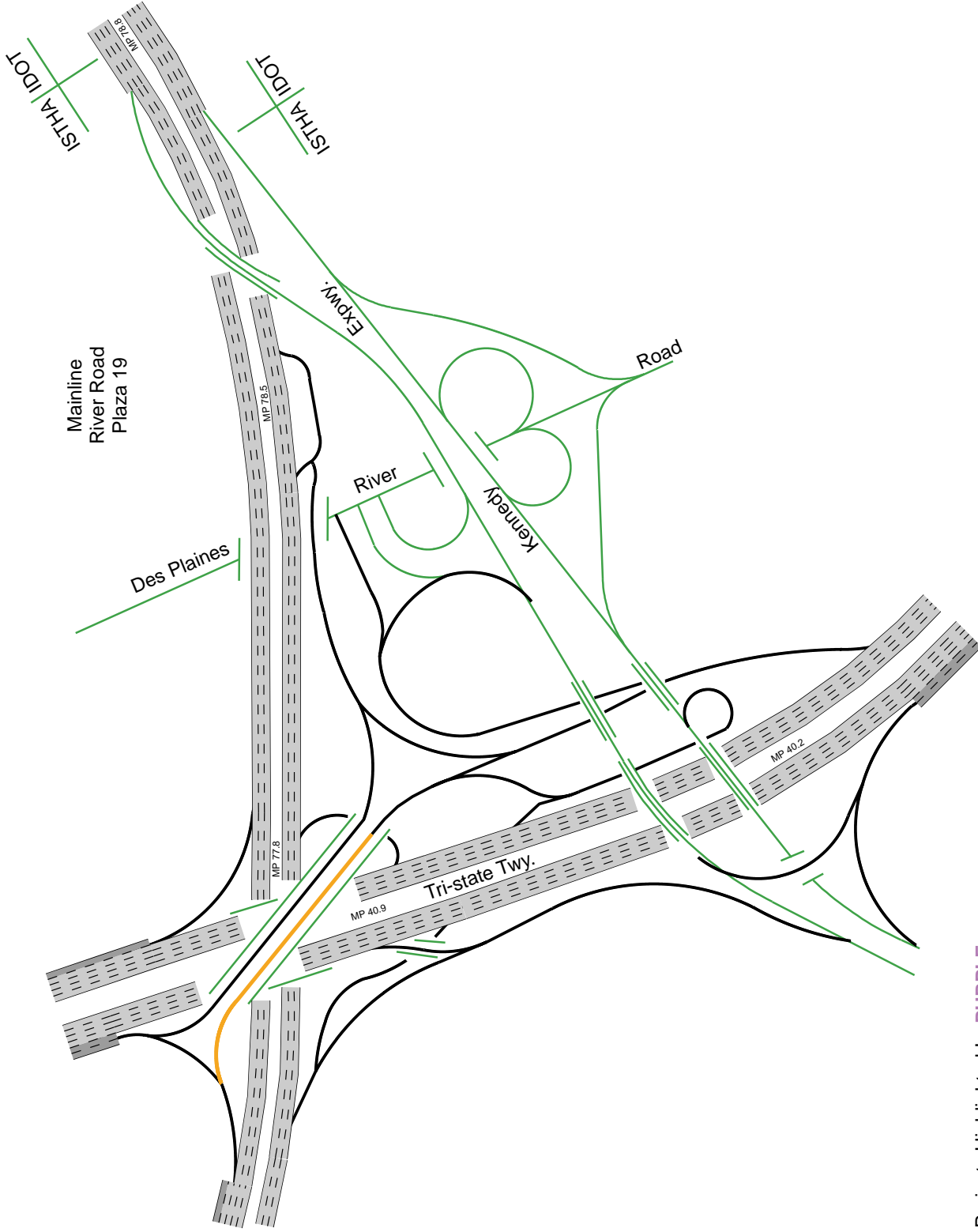

Resurfacing Projects Highlighted In **PURPLE**
Construction Projects Highlighted In **ORANGE**



2012 Lane Configuration

On Tri-State Tollway, from Russell Road to Lake Forest Oasis

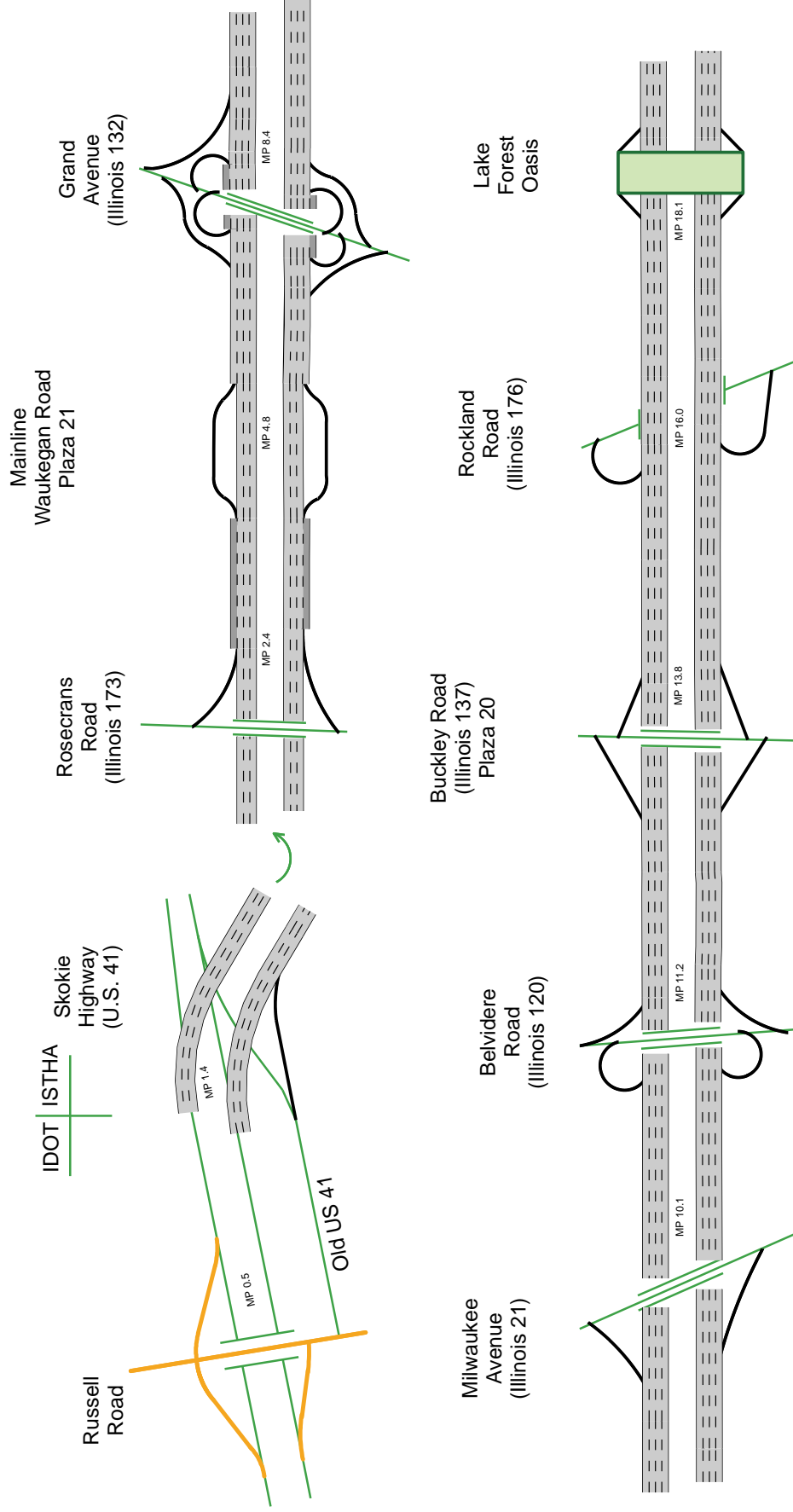

Resurfacing Projects Highlighted In **PURPLE**
Construction Projects Highlighted In **ORANGE**





2012 Lane Configuration

On Tri-State Tollway, from town Line Road (Illinois 60) to Golf Road (Illinois 58) and Edens Spur

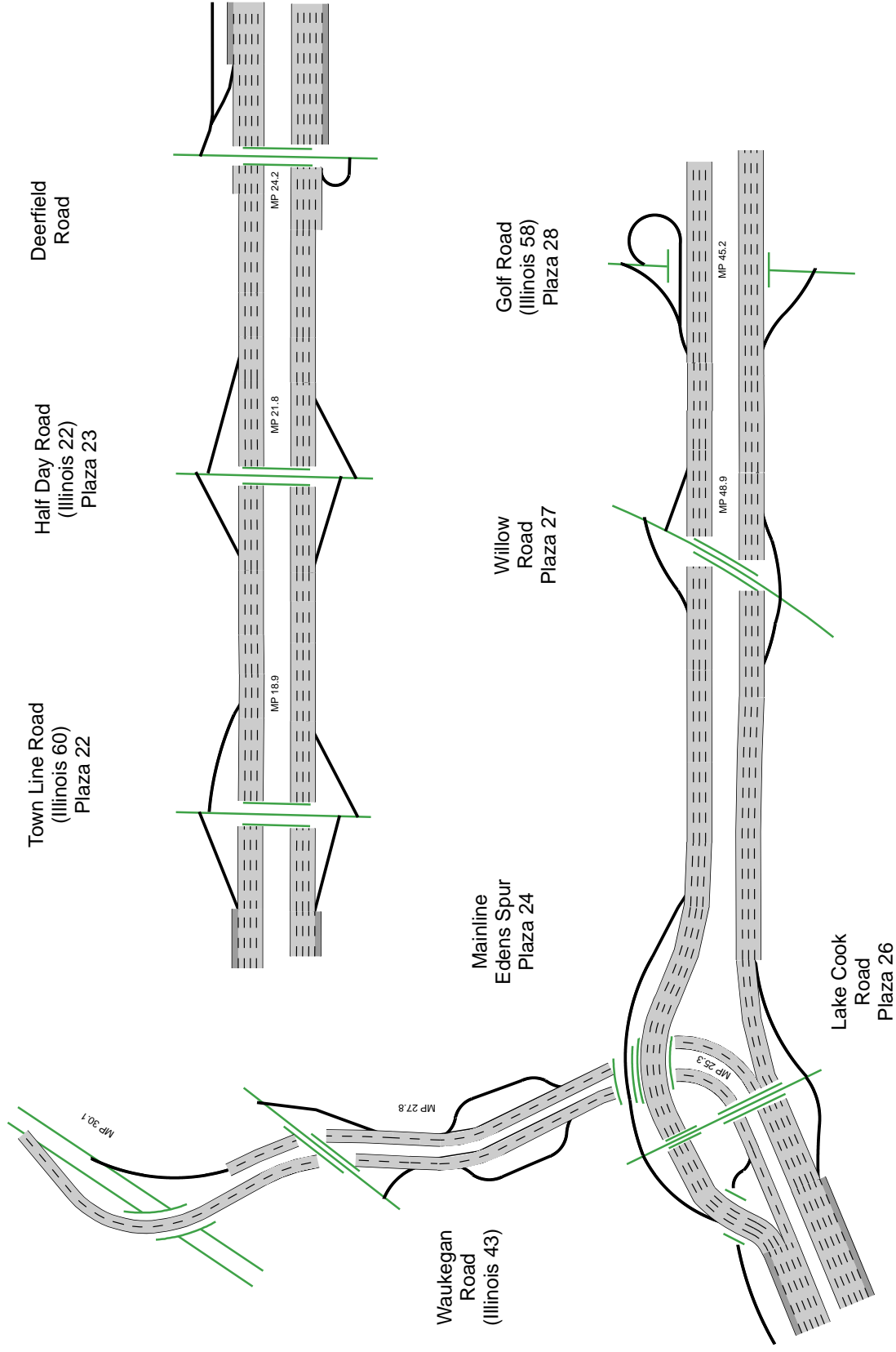

Resurfacing Projects Highlighted In **PURPLE**
Construction Projects Highlighted In **ORANGE**





2012 Lane Configuration

On Tri-State Tollway, from Dempster Street to O'Hare Oasis

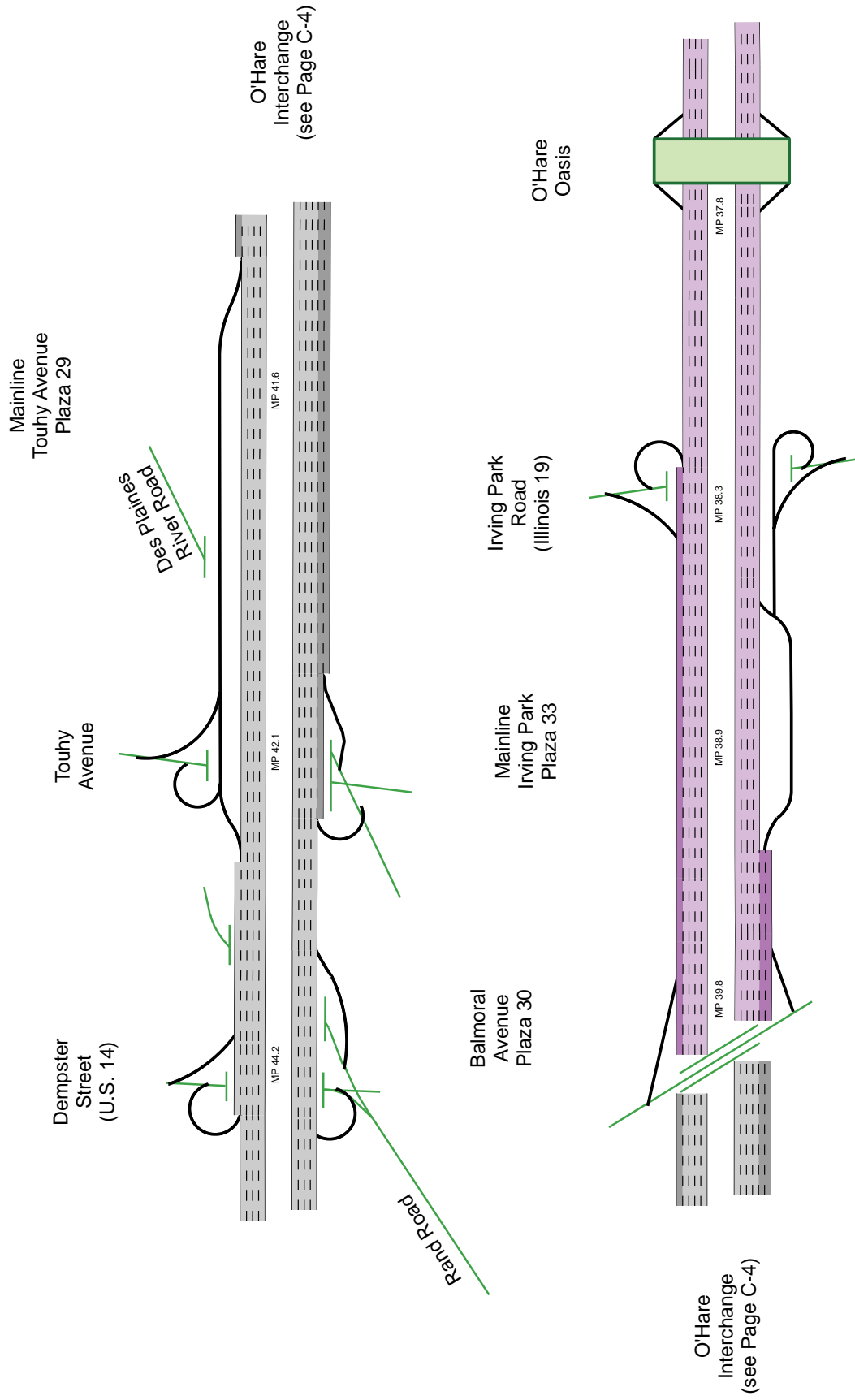

Resurfacing Projects Highlighted In **PURPLE**
Construction Projects Highlighted In **ORANGE**





2012 Lane Configuration

On Tri-State Tollway, from North Avenue / Lake Street to Reagan Memorial Tollway I-88

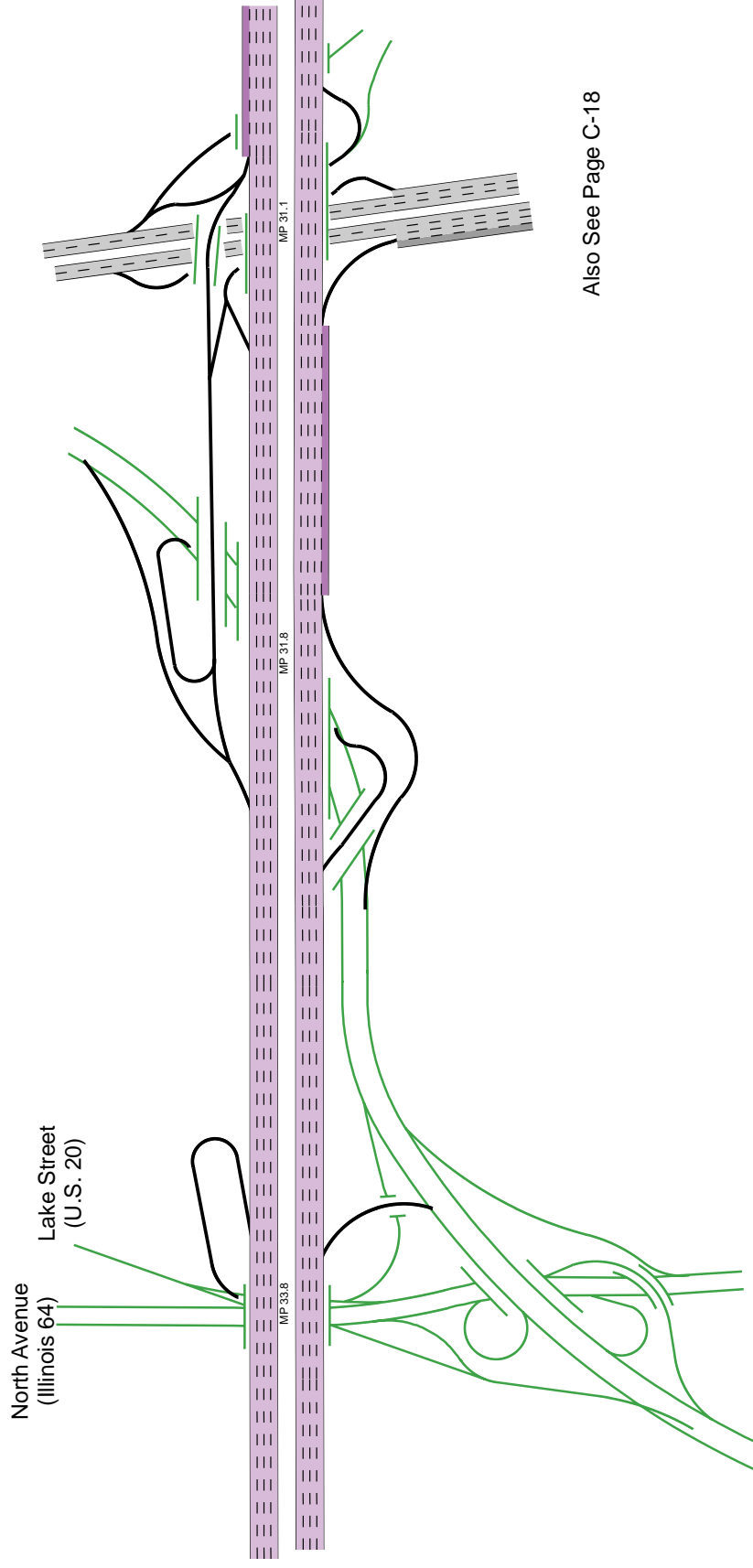

Also See Page C-18

Resurfacing Projects Highlighted In **PURPLE**
Construction Projects Highlighted In **ORANGE**



2012 Lane Configuration

On Tri-State Tollway, from Roosevelt Road to Hinsdale Oasis

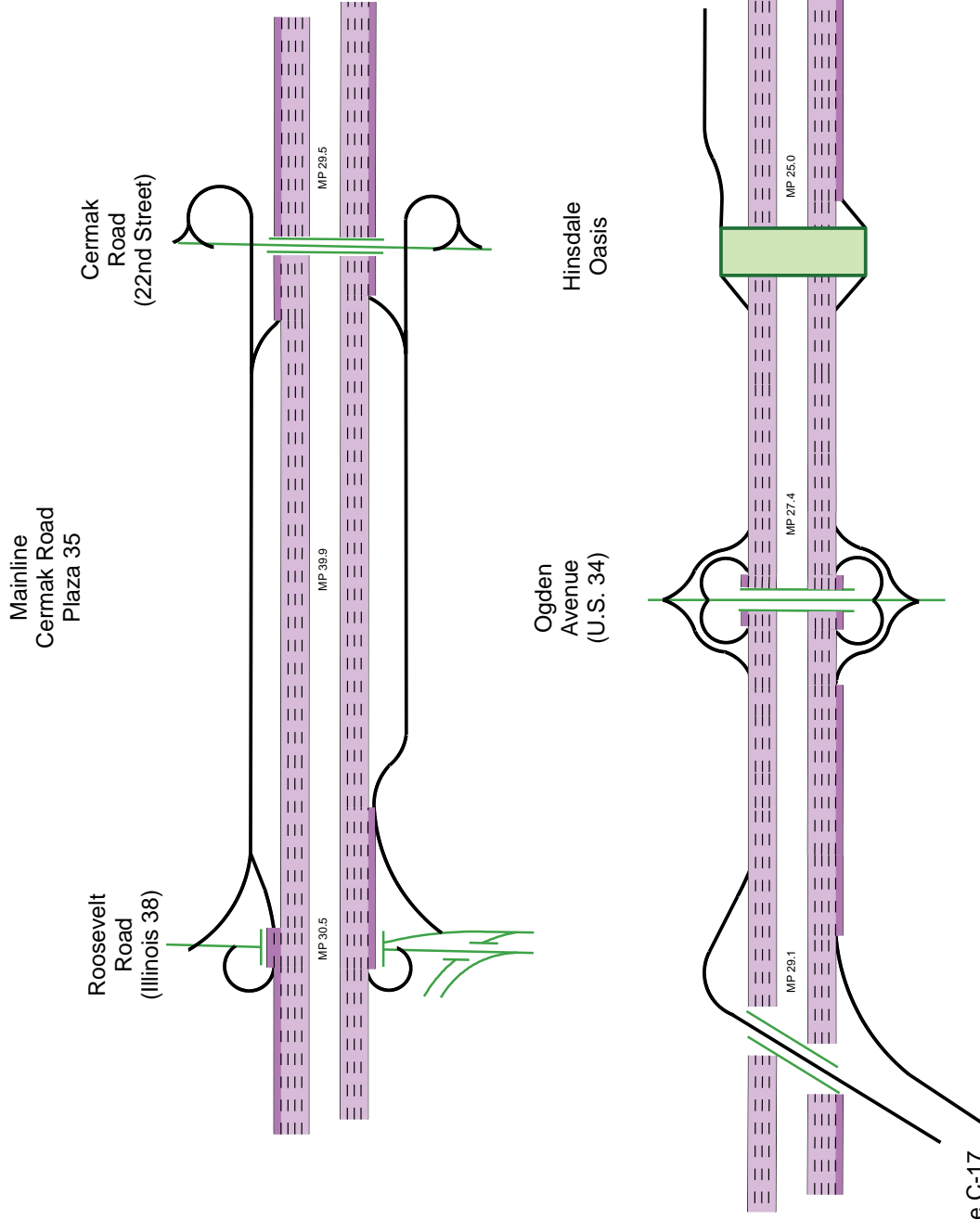

Also See Page C-17

Resurfacing Projects Highlighted In **PURPLE**
Construction Projects Highlighted In **ORANGE**





2012 Lane Configuration On Tri-State Tollway, from Joliet Road (Plaza 37) to Willow Springs Road (Plaza 34)

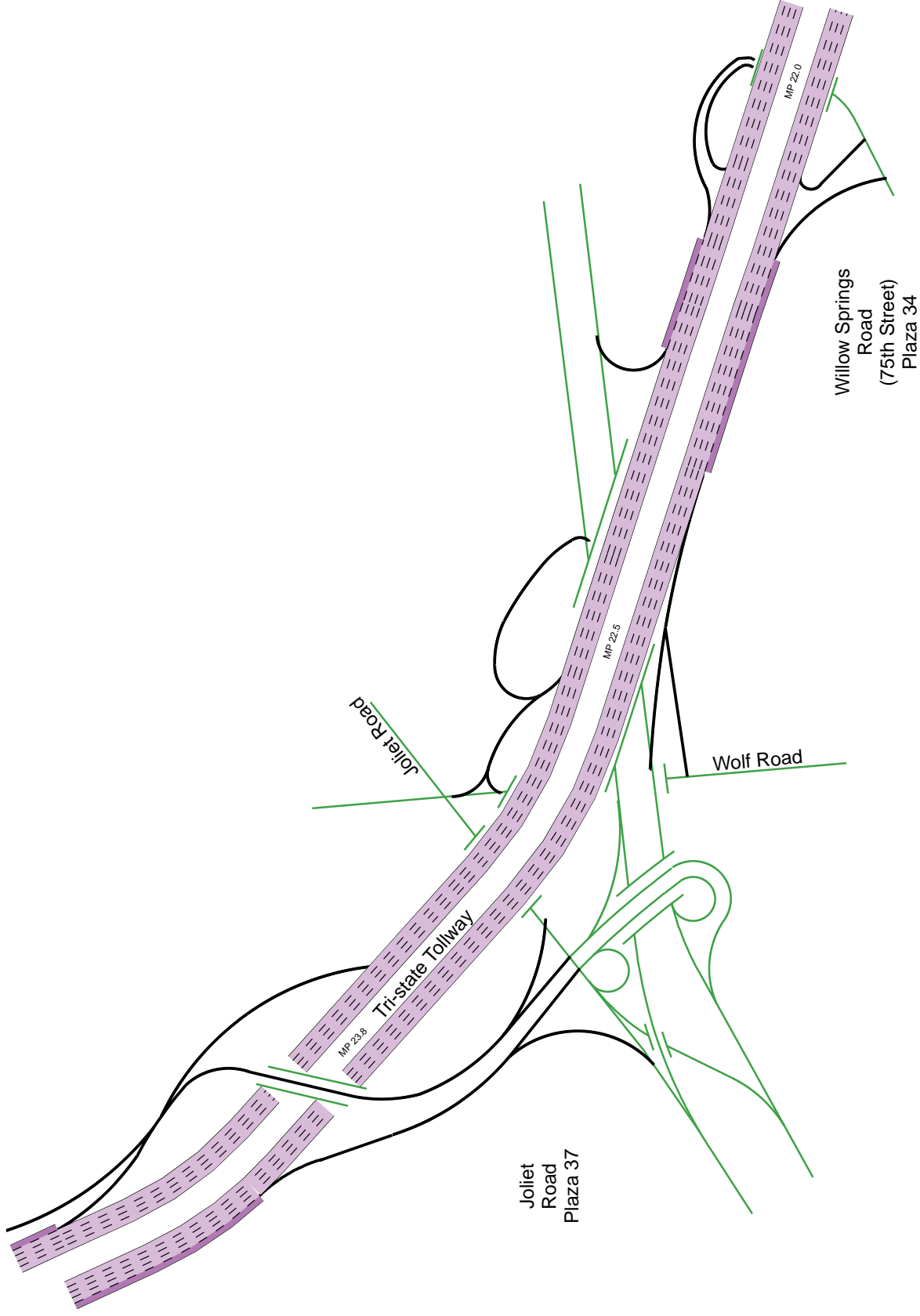

Resurfacing Projects Highlighted In **PURPLE**
Construction Projects Highlighted In **ORANGE**





2012 Lane Configuration

On Tri-State Tollway, from Archer / Lagrange / 79th Street to 163rd Street (Plaza 41)

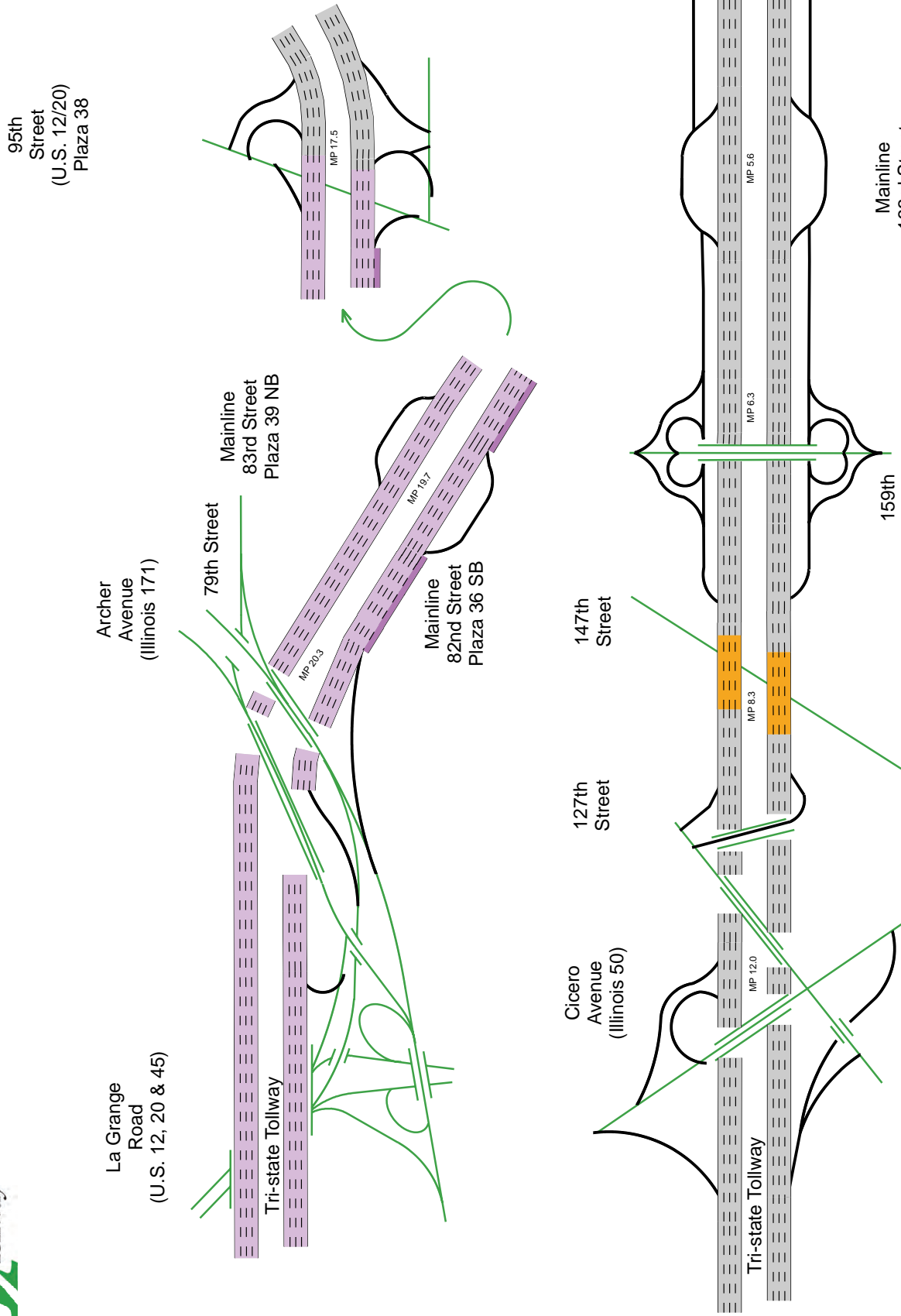

Resurfacing Projects Highlighted In **PURPLE**
Construction Projects Highlighted In **ORANGE**





2012 Lane Configuration

On Tri-State Tollway, from Interstate 80 to Bishop Ford / Kingery Expressway

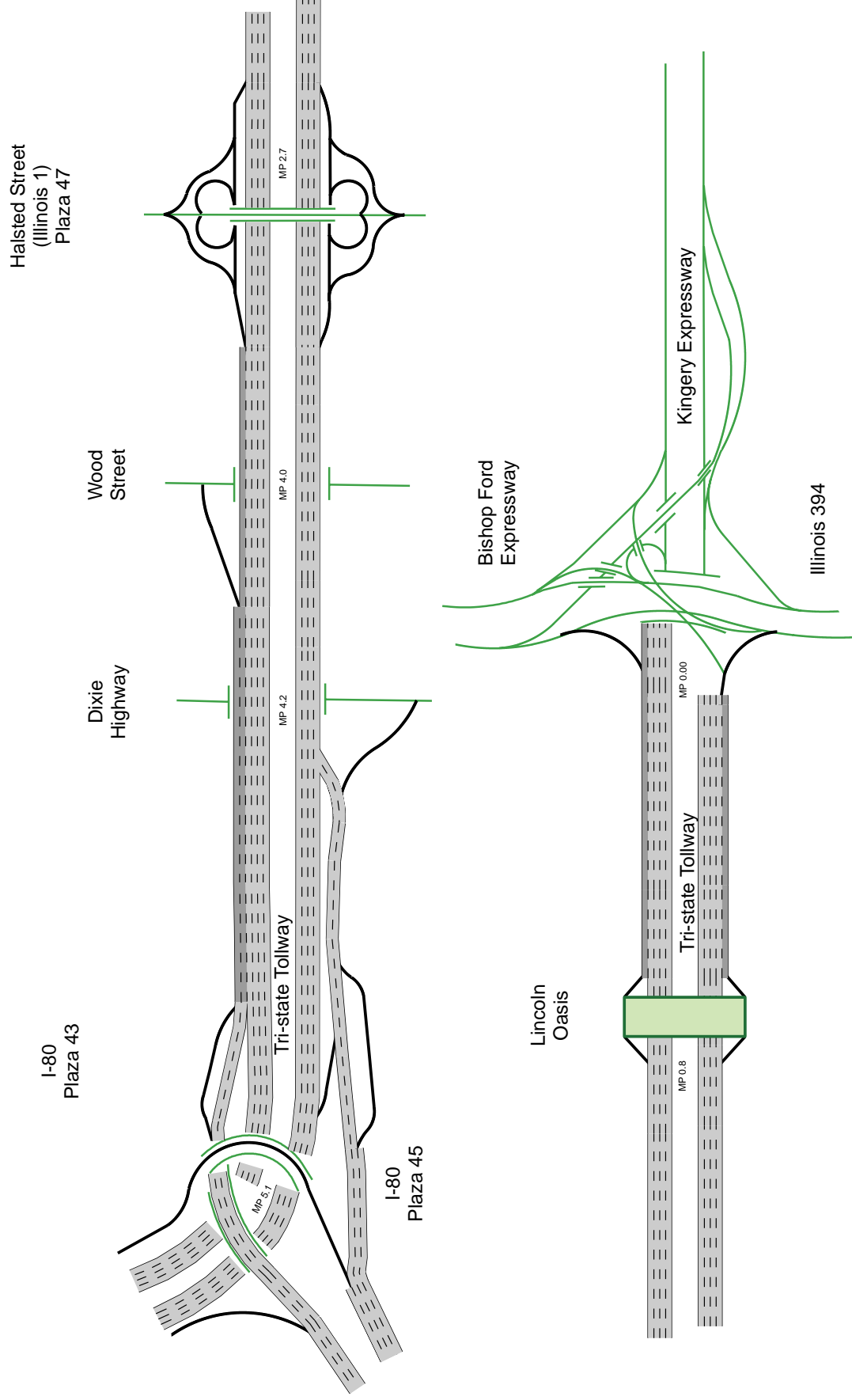

ISTHA IDOT

Resurfacing Projects Highlighted In **PURPLE**
Construction Projects Highlighted In **ORANGE**

C-12





2012 Lane Configuration

On Reagan Memorial Tollway, from Illinois 26 to Orchard Road

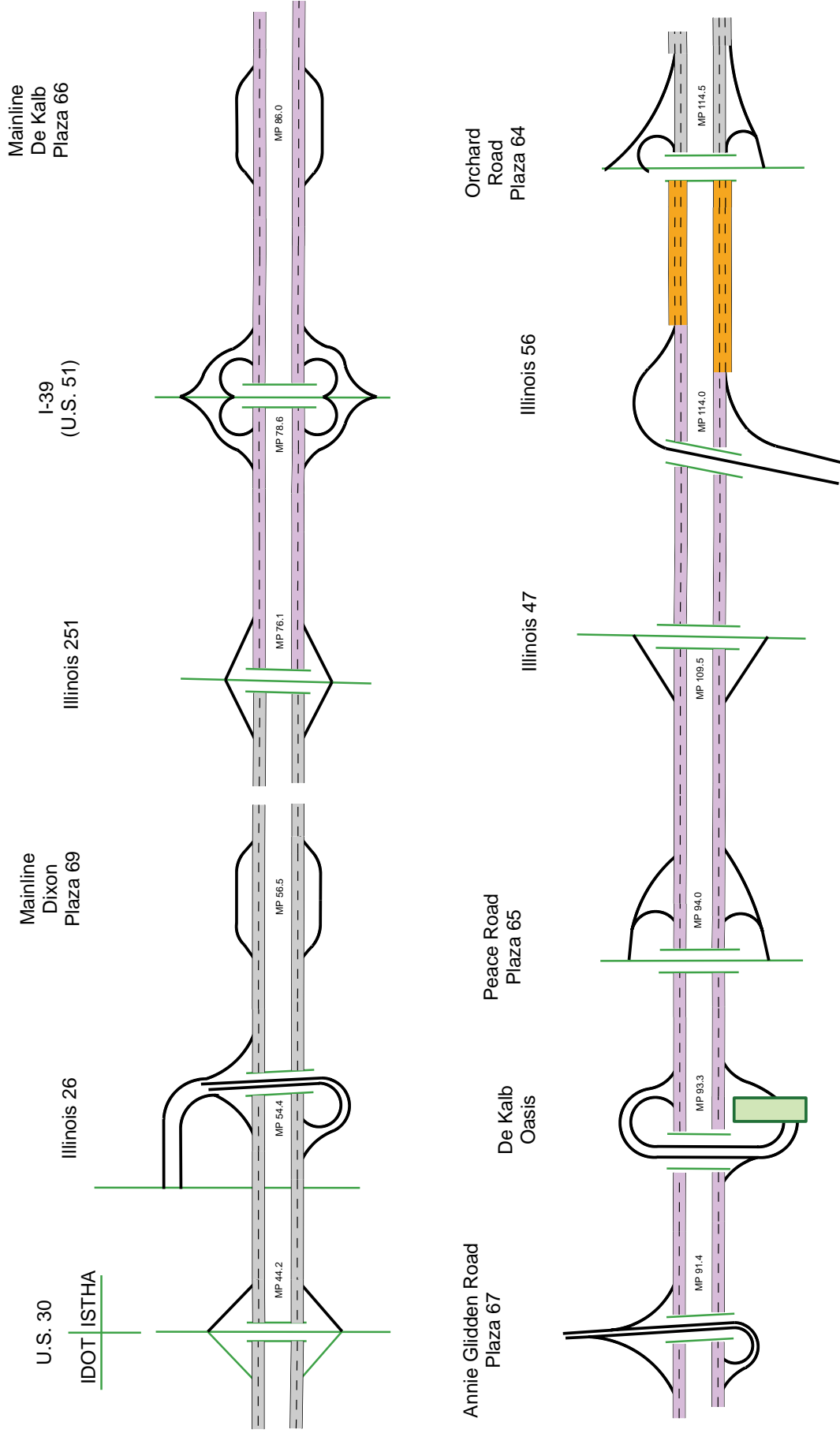

Resurfacing Projects Highlighted In **PURPLE**
Construction Projects Highlighted In **ORANGE**





2012 Lane Configuration

On Reagan Memorial Tollway, from Illinois 31 to Illinois 53

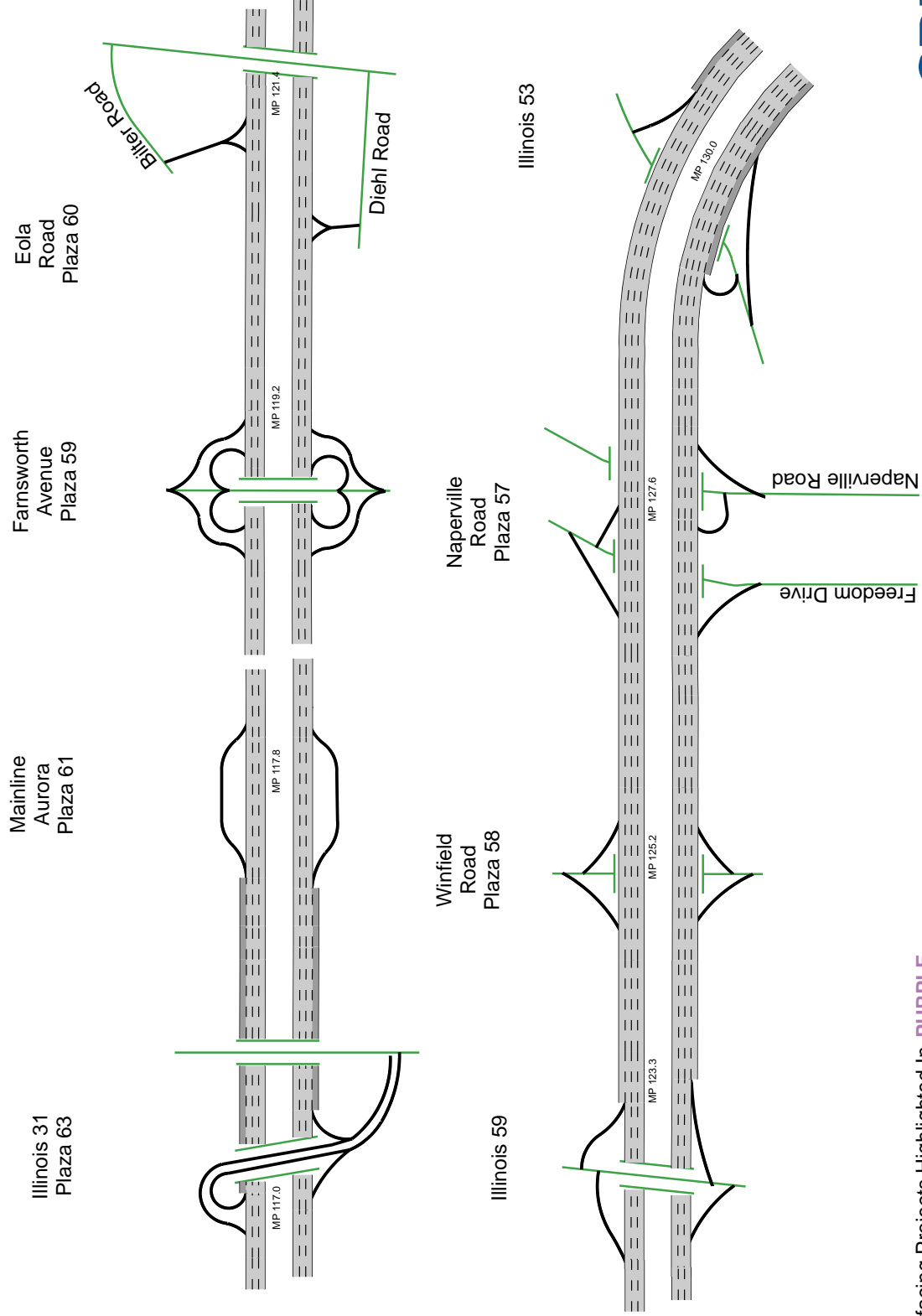

Resurfacing Projects Highlighted In **PURPLE**
Construction Projects Highlighted In **ORANGE**





2012 Lane Configuration

On Reagan Memorial Tollway, Veterans Memorial Tollway West Interchange

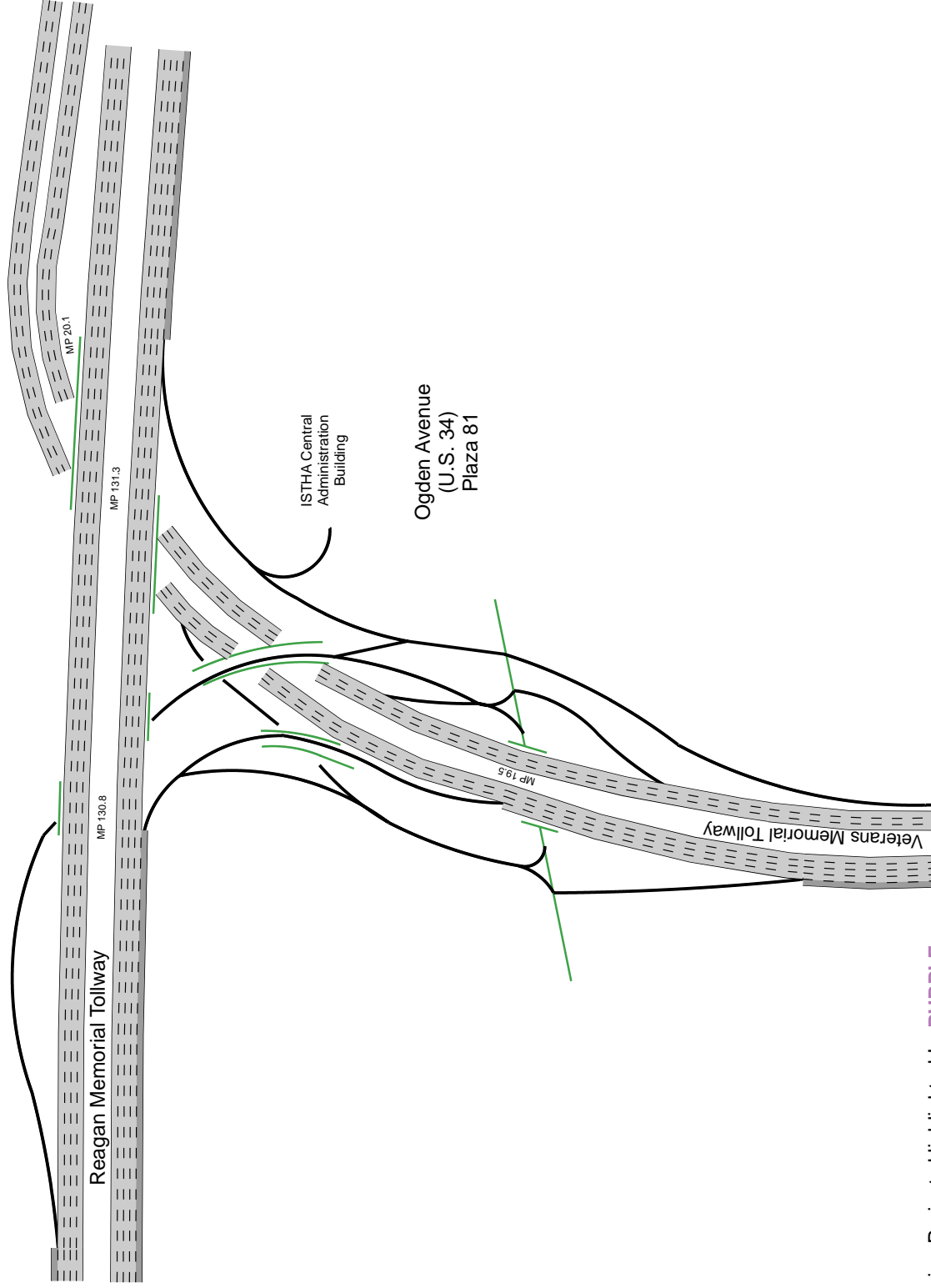

Resurfacing Projects Highlighted In **PURPLE**
Construction Projects Highlighted In **ORANGE**





2012 Lane Configuration

On Reagan Memorial Tollway, Veterans Memorial Tollway East Interchange

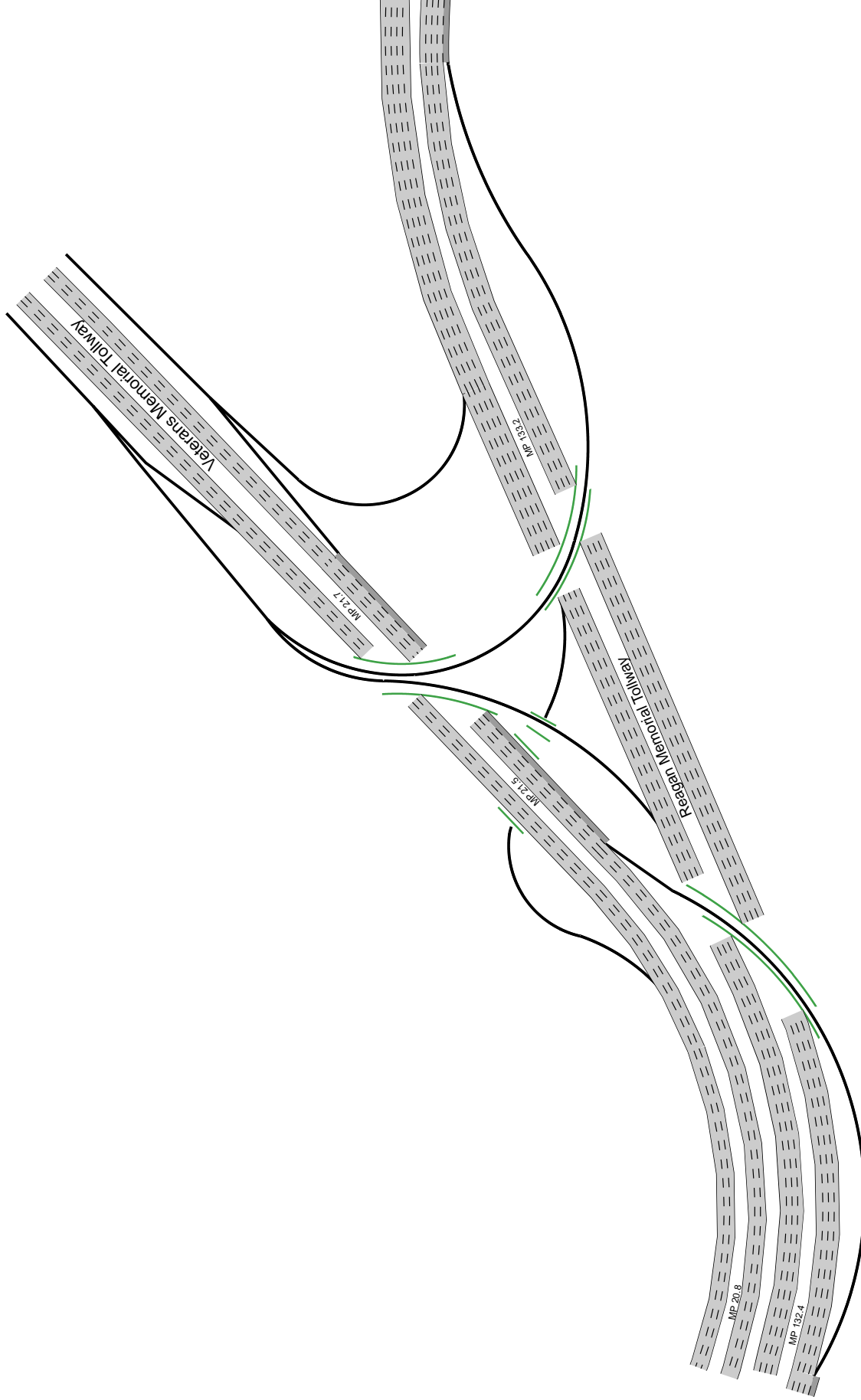

Resurfacing Projects Highlighted In **PURPLE**
Construction Projects Highlighted In **ORANGE**





2012 Lane Configuration

On Reagan Memorial Tollway, from Illinois 31 to Illinois 53

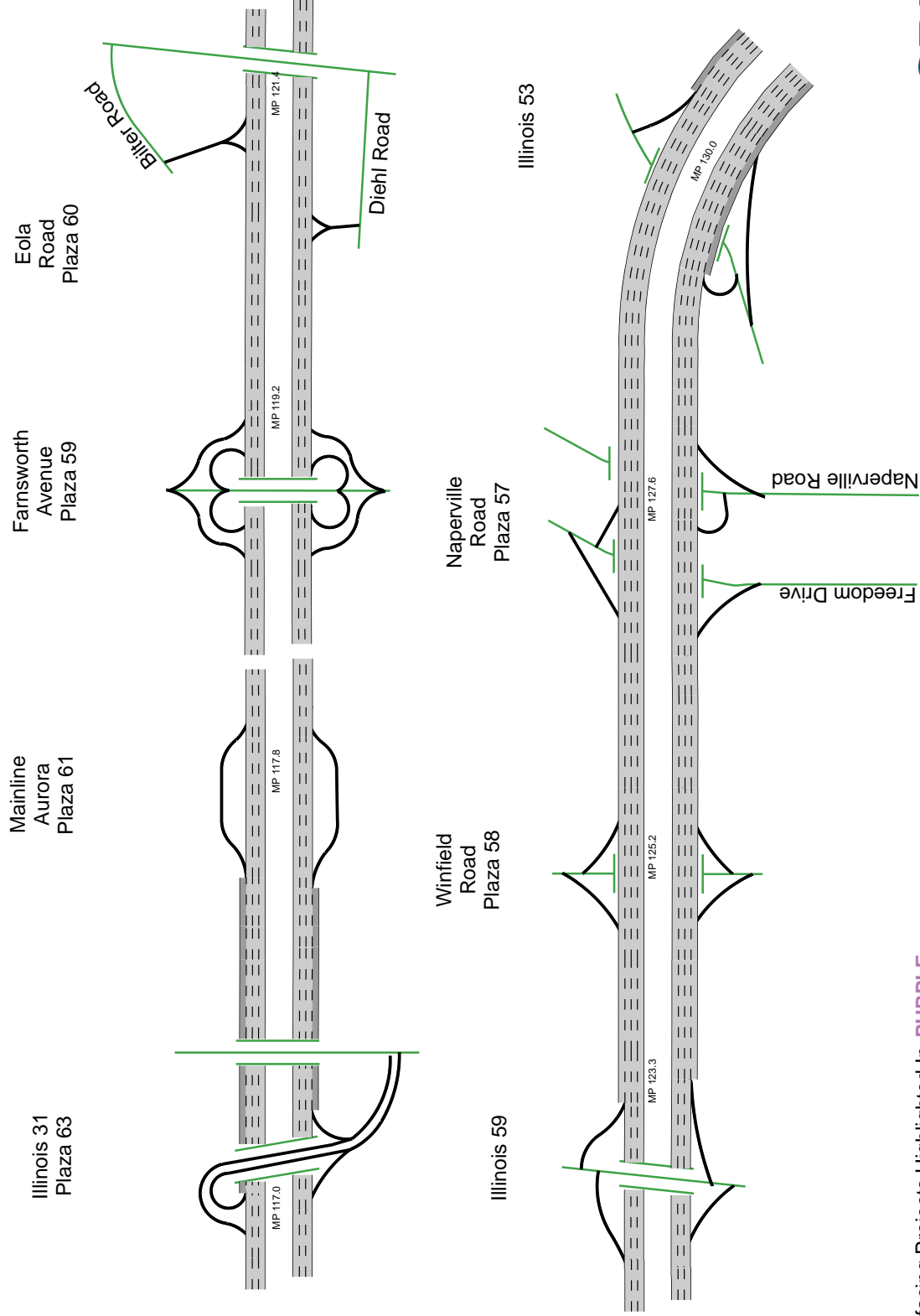

Resurfacing Projects Highlighted In **PURPLE**
Construction Projects Highlighted In **ORANGE**



2012 Lane Configuration

On Reagan Memorial Tollway, from Roosevelt Road to Eisenhower Expressway, I-290

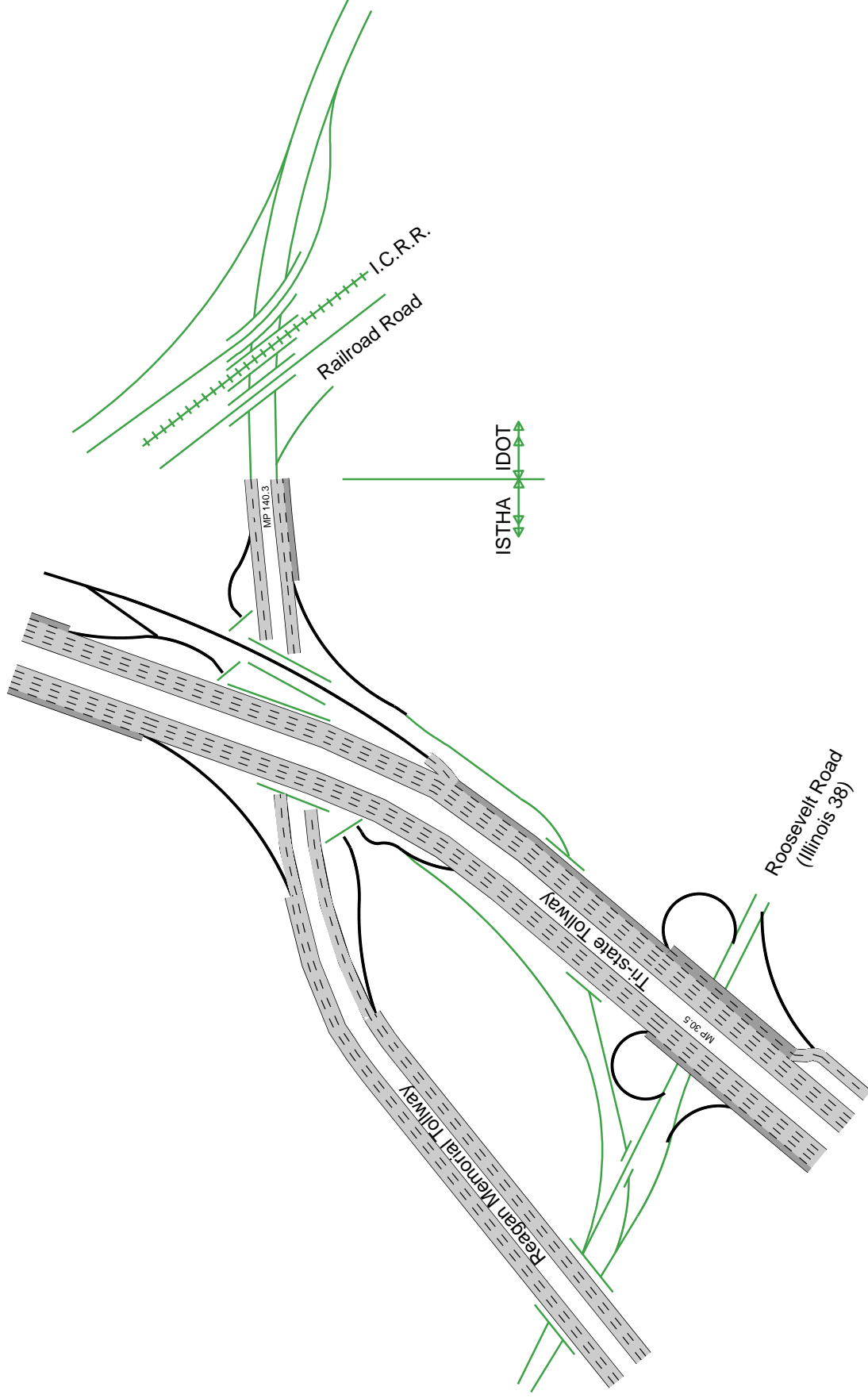

Resurfacing Projects Highlighted In **PURPLE**
Construction Projects Highlighted In **ORANGE**



2012 Lane Configuration

On Veterans Memorial Tollway, from Interstate 80 to 127th Street

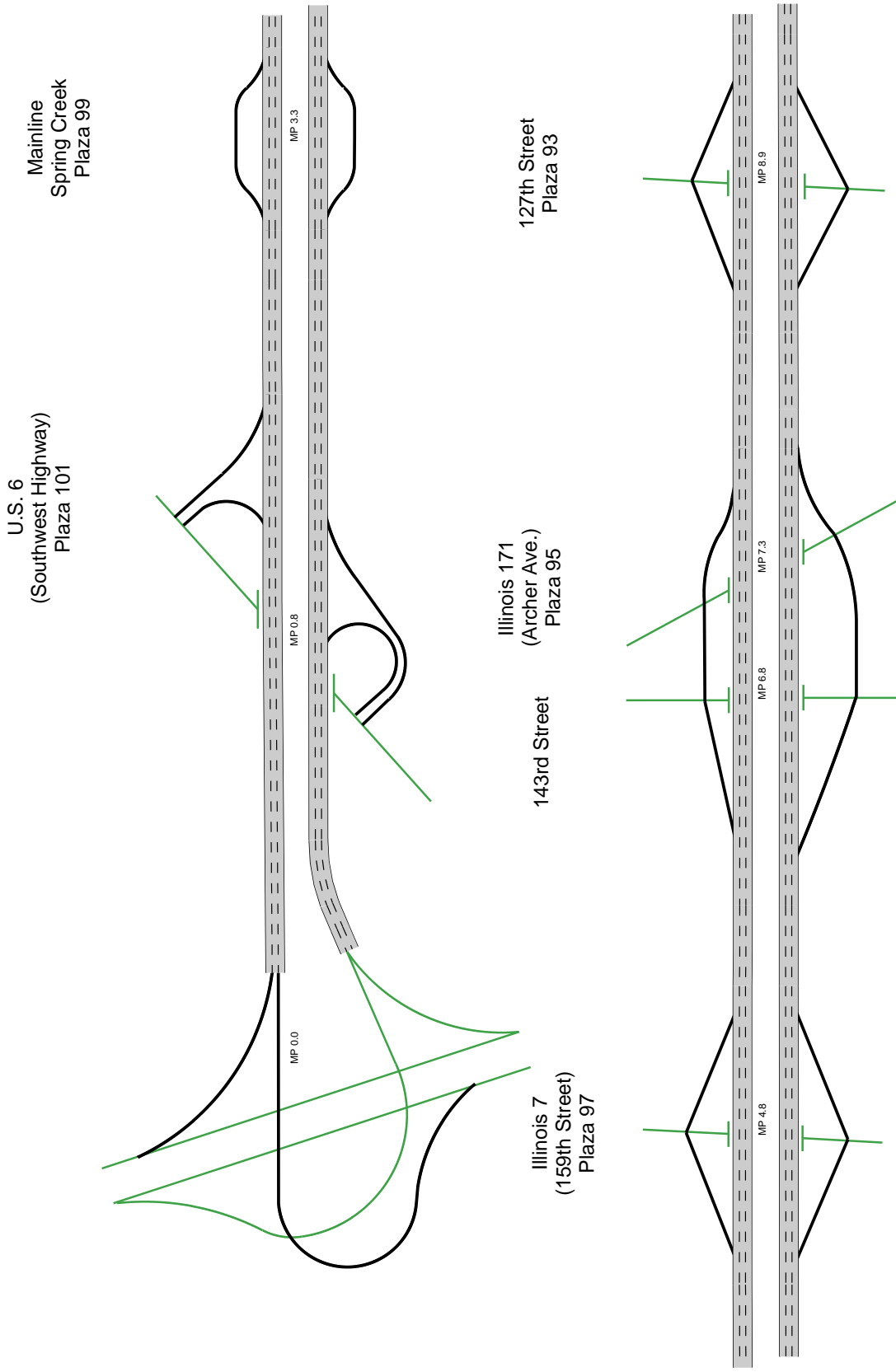

Resurfacing Projects Highlighted In **PURPLE**
Construction Projects Highlighted In **ORANGE**



2012 Lane Configuration On Veterans Memorial Tollway, At Interstate 55

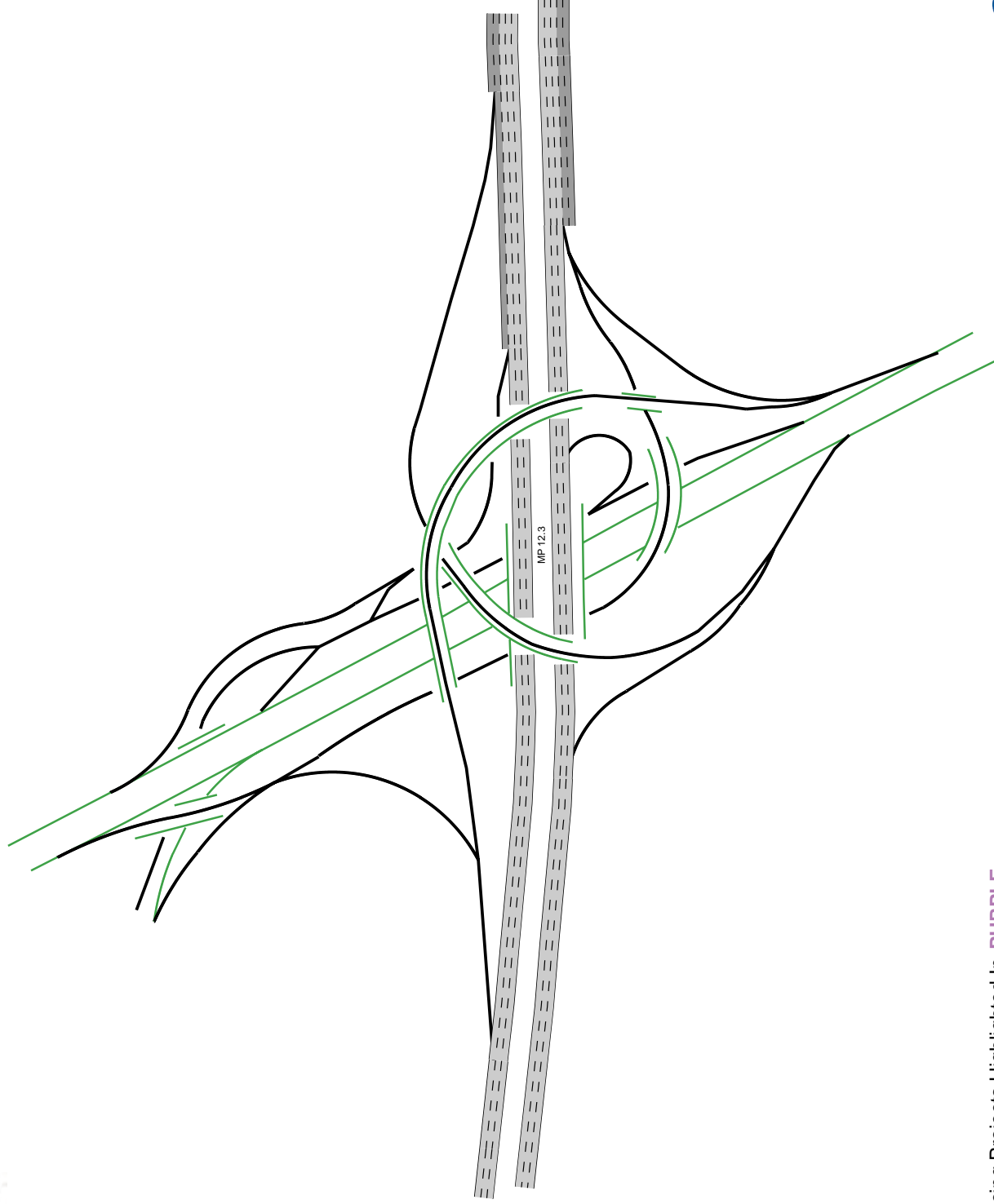

Resurfacing Projects Highlighted In **PURPLE**
Construction Projects Highlighted In **ORANGE**





2012 Lane Configuration

On Veterans Memorial Tollway, from Boughton Road to Maple Avenue

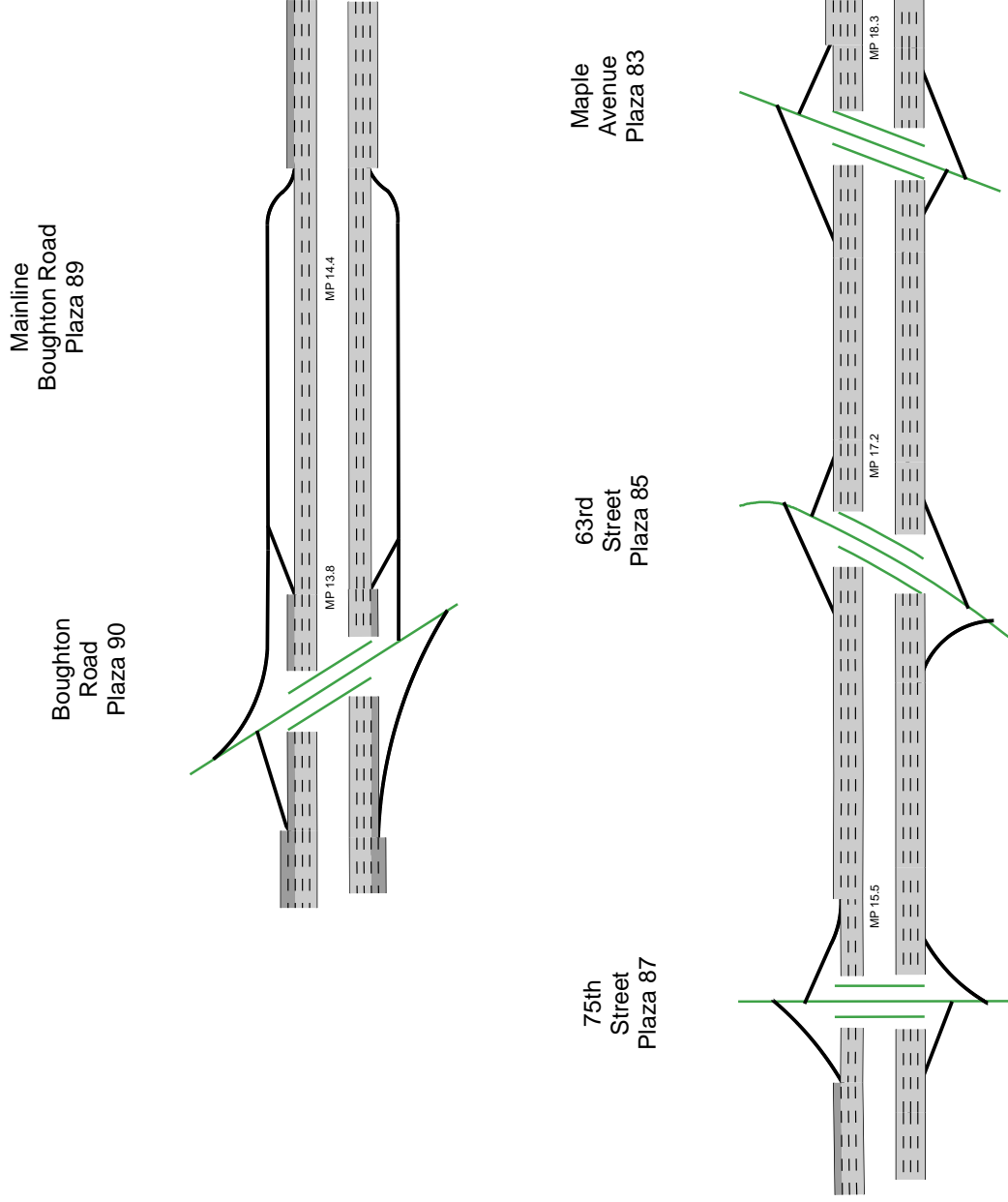

Resurfacing Projects Highlighted In **PURPLE**
Construction Projects Highlighted In **ORANGE**





2012 Lane Configuration

On Veterans Memorial Tollway, from Ogden Avenue / West Interchange to Army Trail Road

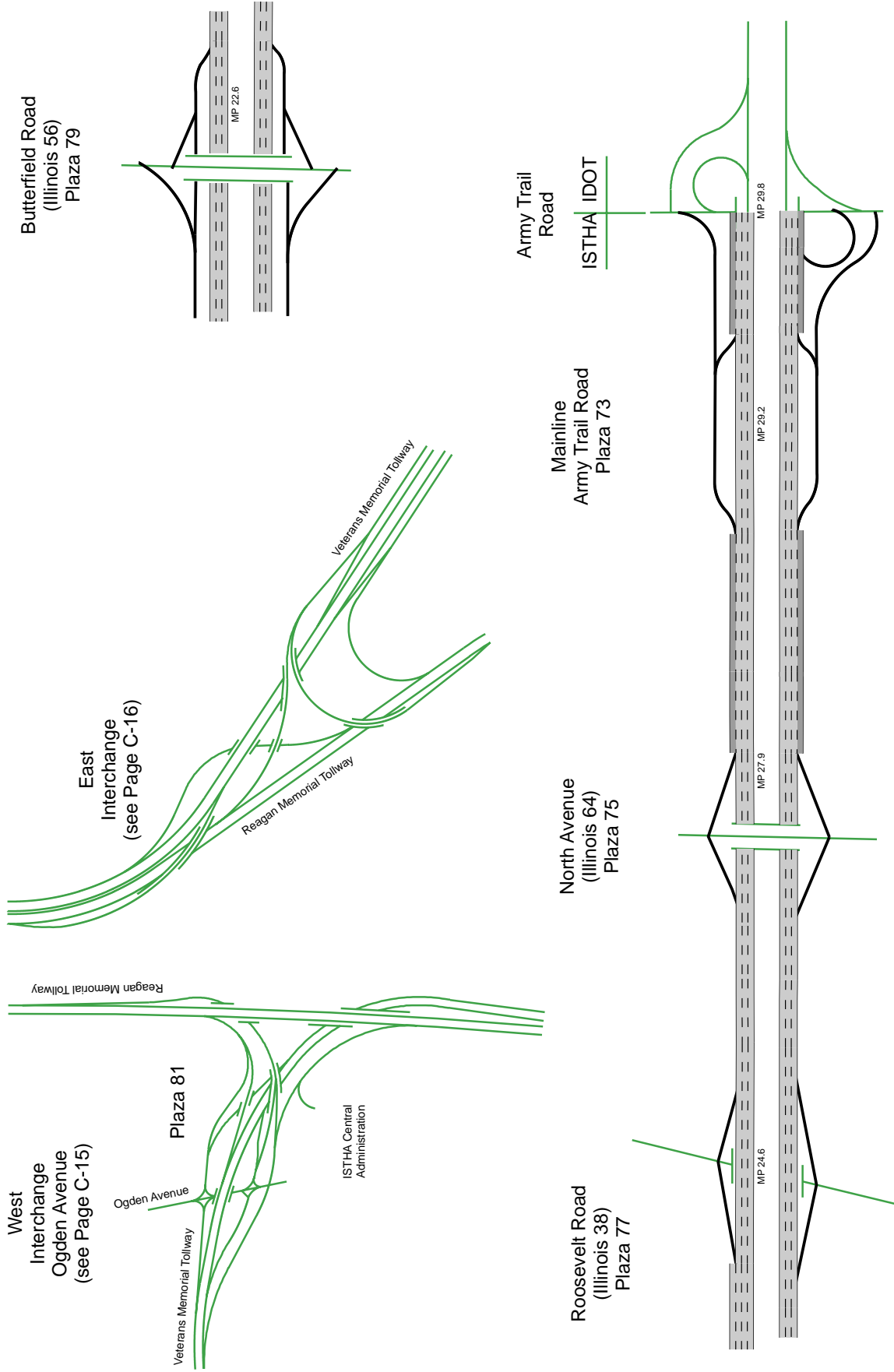

Resurfacing Projects Highlighted In **PURPLE**
Construction Projects Highlighted In **ORANGE**



Appendix D Tab





JANE ADDAMS MEMORIAL TOLLWAY (I-90) PLAZA LANE CONFIGURATION AS OF 8-24-2012

Mainline Plaza No.	Lane Number														Notes								
	EAST							WEST															
1	71	72	73	74	75	51	52	53	54	55	61	62	63	64	65	81	82	83	84	85	Plaza building on eastbound side		
5											54	53	52	51	73	72	71				Serves WB traffic only. Plaza building located on westbound side.		
7	75	74					71	72	73	51	52	53	54							Serves EB only. Plaza building located on eastbound side between lanes 71 & 74. Lanes 74 & 75 are seasonal lanes.			
9	85	84	83	82	81	65	64	63	62	61	55	54	53	52	51	75	74	73	72	71	Plaza building located on westbound side.		
17											56	55	54	53	52	51	76	75	74	73	72	71	Serves WB traffic only. Plaza building located on westbound side.
19	71	72	73	74	75	76	77	51	52	53	54	55									Serves EB traffic only. Plaza building located on eastbound side.		

Ramp Plaza No.	Lane Number														Notes						
	EAST							WEST													
2																					Lanes 1 & 2 exit I-90 WB to East Riverside Blvd. Lane 1 is eastmost. Lanes 3 & 4 enter I-90 EB from East Riverside Blvd.
4																					Lanes 3 & 4 exit I-90 WB to IL 173. Lanes 1 & 2 enter I-90 EB from Rt. 173.
8																					Lanes 1 & 2 exit I-90 EB to Randall Rd. Lanes 3 & 4 enter I-90 WB from Randall Rd.
10																					Lanes exit I-90 WB to Barrington Rd. Lane 4 is closest to the mainline.
11																					Lanes 1 & 5 exit I-90 WB to IL 31 NB. Lane 2 enters I-90 EB from IL 31 NB. Lane 3 enters I-90 EB from IL 31 SB. Lane 4 exits I-90 WB to IL 31 SB.
12																					Lanes exit I-90 WB to Roselle Rd. Lane 1 is closest to control building. Lane 3 closest to mainline.
13																					Lane 1 enters I-90 EB from IL 25. Lane 2 exits I-90 WB to IL 25.
14																					Lanes 4 - 6 exit I-90 EB to IL 59. Lane 4 is closest to mainline.
15																					Lanes 1 - 3 exit I-90 EB to IL 53 NB. Lanes 4 - 7 exit I-90 EB to IL 53 SB. Lane 4 is closest to mainline.
16a																					Lanes 7 - 9 exit I-90 WB to IL 59. Lane 9 closest to mainline. Signed as 14 on plaza canopy.
16b																					Lanes 10 & 11 exit I-90 WB to Beverly Rd. Signed as 14A on plaza canopy. Lane 11 is closest to mainline.
18																					Lanes 1 - 3 enter I-90 WB from Arlington Heights Rd. Lane 1 is northmost. Lanes 4 - 6 exit I-90 EB to Arlington Heights Rd.

	Count
Open Road Tolling Lanes (ORT)	23
Manual Lane Toll (MLT)	36
Shoulder	16
I-PASS Only Lane (IPO)	27
Automatic Coin Machine Lane (ACM)	23
Closed Lane/Other	2
II = Center Line/Main Line	-
Λ = Change in Movement/Direction	-





TRI-STATE TOLLWAY (I-94/I-294) PLAZA LANE CONFIGURATION AS OF 8-24-2012

Mainline Plaza No.	Lane Number																Notes
	SOUTH / EAST								NORTH / WEST								
21	85	84	83	82	81	80	79	78	77	76	75	74	73	72	71	70	Plaza building located on east side.
24																	Plaza building located on south side.
29																	Serves NB traffic only. Plaza building located on east side.
33																	Serves SB traffic only. Plaza building located on west side.
35																	Plaza building located on east side.
36																	Serves NB traffic only. Plaza building located on east side.
39																	Main plaza building located on east side.
41																	

Ramp Plaza No.	Lane Number																Notes
	SOUTH / EAST								NORTH / WEST								
20																	Lanes 1 & 2 enter I-94 NB. Lane 1 is eastmost. Lanes 3 & 4 exit I-94 SB. Lane 4 is westmost.
22																	Lanes 1 & 2 enter I-94 NB. Lane 1 is eastmost. Lanes 3 & 4 exit I-94 SB. Lane 4 is westmost.
23																	Lanes 1 & 2 enter I-94 NB. Lane 1 is eastmost. Lanes 3 & 4 exit I-94 SB. Lane 4 is westmost.
26																	Lanes 10 - 12 enter I-294 NB. Lane 12 is eastmost. Lanes 7 - 9 exit I-294 SB. Lane 7 is westmost.
27																	Lanes 9 - 11 enter I-294 NB. Lane 9 is eastmost. Lanes 12 - 14 exit I-294 SB. Lane 14 is westmost.
28																	Lanes 1 - 3 enter I-294 NB. Lane 1 is eastmost. Lanes 4 - 6 exit I-294 SB. Lane 6 is westmost.
30																	Lanes 51-53 exit I-294 NB. Lane 53 is westmost.
31																	Lane 1 is closest to the plaza building (northmost).
32																	Lane 1 is closest to the plaza building (southmost).
34																	Lanes 1 - 3 exit I-294 SB. Lanes 4 - 6 enter I-294 NB.
37																	Lanes 1 - 5 exit I-294 SB. Lane 1 is closest to the plaza building (westmost).
38																	Lanes 6 - 10 enter I-294 NB. Lane 10 is eastmost.
40																	Lanes 1 & 2 exit I-294 NB. Lane 1 is eastmost. Lanes 3 & 4 enter I-294 SB. Lane 4 is westmost.
43																	Lanes 1 & 2 enter NB I-294 from WB 159th St. Lanes 3 & 4 enter NB I-294 from EB 159th St. Lanes 5 & 6 exit SB I-294 to EB 159th St. Lanes 7 & 8 exit SB I-294 to WB 159th St.
45																	Plaza to continue on I-80 WB from the southernmost portion of the Tri-State Tollway.
47																	Plaza to enter the southernmost portion of the Tri-State Tollway from I-80 EB.

	Count
Open Road Tolling Lanes (ORT)	48
Manual Lane Toll (MLT)	64
Shoulder	29
I-PASS Only Lane (IPO)	45
Automatic Coin Machine Lane (ACM)	34
Closed Lane/Other	2
II = Center line/Main line	-
∧ = Change in Movement/Direction	-





REAGAN MEMORIAL TOLLWAY (I-88) PLAZA LANE CONFIGURATION AS OF 8-24-2012

Mainline Plaza	Lane Number														Notes						
	EAST							WEST													
No. Name	II	51	52	53	54	55	56	75	74	73	72	71	II	71	72	73	74	75	76	77	
51 York Rd.																					Serves WB traffic only, Plaza building located on north side.
52 Meyers Rd.																					Serves EB traffic only, Plaza building located on south side.
61 Aurora																					Plaza building located on south side
66 DeKalb																					Plaza building located on south side
69 Dixon																					Plaza building located on south side

Ramp Plaza	Lane Number														Notes				
	EAST							WEST											
No. Name	II	1	2	3	II	60	II	1	2	3	II	60	II	1	2	3	II	60	
53 Spring Rd. (22nd St.)																			All lanes enter I-88 WB from Spring Rd. Lane 1 is eastmost.
54 Illinois 83																			All lanes enter I-88 EB from IL 83.
55 Midwest Rd.																			All lanes enter I-88 EB from Midwest Rd.
56 Highland Ave.																			Lanes 1 & 2 enter I-88 WB from Downers Dr. Lane 1 is westmost. Lanes 3 & 4 exit I-88 EB to Highland Ave. Lane 4 is southmost.
57 Naperville Rd.																			Lanes 4 & 5 enter I-88 WB from Naperville Rd. Lanes 2 & 3 exit I-88 EB to Naperville Rd.
58 Winfield Rd.																			Lanes 5 & 6 exit I-88 EB to Winfield Rd. Lane 5 is southmost. Lanes 7 & 8 enter I-88 WB from Winfield Rd. Lane 8 is closest to Winfield Rd.
59 Farnsworth Ave.																			Lanes 1 & 5 exit I-88 WB to NB Farnsworth Ave. Lane 2 enters I-88 EB from NB Farnsworth Ave. Lanes 3 and 7 enter I-88 EB from SB Farnsworth Ave. Lane 4 exits I-88 WB to SB Farnsworth Ave.
60 Eola Rd.																			Lanes 52 & 53 exit I-88 WB to Bitter Rd. Lane 63 is westmost. Lanes 62 & 63 enter I-88 EB from Dient Rd. Lane 53 is westmost.
63 Illinois 31																			Lane 1 enters I-88 WB from IL 31. Lane 2 exits I-88 EB to IL 31.
64 Orchard Rd.																			Lanes 1 & 2 enter I-88 WB from Orchard Rd. Lane 2 is closest to mainline. Lanes 3 & 4 exit I-88 EB to Orchard Rd. Lane 3 is
65 Peace Rd.																			Lanes 1 & 2 exit I-88 WB to Peace Rd. Lane 1 is northmost. Lanes 3 & 4 enter I-88 EB from Peace Rd. Lane 4 is southmost.
67 Annie Glidden Rd.																			Lanes 3 & 4 exit I-88 WB to Annie Glidden Rd. Lanes 1 & 2 enter I-88 EB from Annie Glidden Rd.

	Count
Open Road Tolling Lanes (ORT)	26
Manual Lane Toll (MLT)	28
Shoulder	17
I-PASS Only Lane (IPO)	19
Automatic Coin Machine Lane (ACM)	22
Closed Lane/Other	10
II = Center line/Main line	-
∧ = Change in Movement/Direction	-





VETERANS MEMORIAL TOLLWAY (I-355) PLAZA LANE CONFIGURATION AS OF 8-24-2012

Mainline Plaza		Lane Number														Notes									
No.	Name	SOUTH							NORTH																
73	Army Trail	71	72	73	74	75	76	51	52	53	54	55	II	61	62	63	64	65	81	82	83	84	85	Plaza building located on west side.	
89	Boughton Rd.	71	72	73	74	75	76	51	52	53	54	55	II	61	62	63	64	65	81	82	83	84	85	86	Plaza building located on west side.
99	Spring Creek												II	55	54	53	52	51	73	72	71			Plaza building located on west side.	

Ramp Plaza		Lane Number														Notes								
No.	Name	SOUTH							NORTH															
75	North Ave. (IL 64)							6	5	4	II	3	2	1										Lanes 1 - 3 exit I-355 NB to North Ave. Lane 1 is eastmost.
77	Roosevelt Rd. (IL 38)											1	2	3	4									Lanes 1 & 2 enter I-355 SB from Roosevelt Rd. Lane 1 is closest to control building (westmost). Lanes 3 & 4 exit I-355 NB to Roosevelt Rd. Lane 4 is eastmost.
79	Butterfield Rd. (IL 56)											1	2	II	4	3								Lanes 1 & 2 enter I-355 SB from Butterfield Rd. Lane 1 is closest to control building (westmost). Lanes 3 & 4 exit I-355
81	Ogden Ave. (US 34)											1	2	II	3	4								Lanes 1 & 2 exit I-88 EB to Ogden Ave. Lane 1 is westmost. Lanes 3 & 4 enter I-88 WB from Ogden Ave. Lane 4 is east-
83	Maple Ave.							1	2	3	II	4	5	6										Lanes 1 - 3 exit I-355 SB to Maple Ave. Lane 1 is westmost. Lanes 4 - 6 enter I-355 from Maple Ave. Lane 6 is eastmost.
85	63rd St.											6	5	4	II	3	2	1						Lanes 1 - 3 enter I-355 NB from 63rd St. Lane 1 is eastmost. Lanes 4 - 6 exit I-355 SB to 63rd St. Lane 6 is westmost.
87	75th St.											6	5	4	II	3	2	1						Lanes 1 - 3 enter I-355 NB from 75th St. Lane 1 is eastmost. Lanes 4 - 6 exit I-355 SB to 75th St. Lane 6 is westmost.
90	Boughton Rd.														1	2	II	3	4					Lanes 1 & 2 enter I-355 SB from Boughton Rd. Lanes 3 & 4 exit I-355 NB to Boughton Rd.
93	127th St.																							Lanes 3 & 4 enter I-355 NB from 127th St. Lanes 1 & 2 exit I-355 SB to 127th St.
95	Illinois 171 (Archer Ave.)														1	2	II	3	4					Lanes 3 & 4 enter I-355 NB from Archer Ave. Lanes 1 & 2 exit I-355 SB to Archer Ave.
97	Illinois 7 (159th St.)																							Lanes 3 & 4 enter I-355 NB from Route 7. Lanes 1 & 2 exit I-355 SB to IL 7.
101	US 6														3	4	II	1	2					Lanes 3 & 4 enter I-355 SB from Route 6. Lanes 1 & 2 exit I-355 NB to US 6.

	Count
Open Road Tolling Lanes (ORT)	18
Manual Lane Toll (MLT)	21
Shoulder	12
IPASS Only Lane (IPO)	36
Automatic Coin Machine Lane (ACM)	24
Closed Lane/Other	4
II = Center Line/Main line	-
I = Change in Movement/Direction	-







 *Illinois Tollway*

**CDM
Smith**